

# SUBMISSION FOR PERMANENT RULE

<b>1. Rule-Making Agency: NC Building Code Council</b>	
<b>2. Rule citation &amp; name (name not required for repeal):</b> 2024 North Carolina Energy Conservation Code (221213 Item B-6)	
<b>3. Action:</b> <input type="checkbox"/> ADOPTION <input checked="" type="checkbox"/> AMENDMENT <input type="checkbox"/> REPEAL <input type="checkbox"/> READOPTION <input type="checkbox"/> REPEAL through READOPTION	
<b>4. Rule exempt from RRC review?</b> <input type="checkbox"/> Yes. Cite authority: <input checked="" type="checkbox"/> No	<b>5. Rule automatically subject to legislative review?</b> <input type="checkbox"/> Yes. Cite authority: <input checked="" type="checkbox"/> No
<b>6. Notice for Proposed Rule:</b> <input checked="" type="checkbox"/> <b>Notice Required</b> Notice of Text published on: September 15, 2023 in NC Register, August 28, 2023 agency website Link to Agency notice: <a href="https://www.ncosfm.gov/231017-notice1hearing">https://www.ncosfm.gov/231017-notice1hearing</a> Hearing on: October 17, 2023 Adoption by Agency on: December 12, 2023 <input type="checkbox"/> <b>Notice not required under G.S.:</b> Adoption by Agency on:	
<b>7. Rule establishes or increases a fee? (See G.S. 12-3.1)</b> <input type="checkbox"/> Yes Agency submitted request for consultation on: Consultation not required. Cite authority: <input checked="" type="checkbox"/> No	<b>8. Fiscal impact. Check all that apply.</b> <input type="checkbox"/> This Rule was part of a combined analysis. <input type="checkbox"/> State funds affected <input checked="" type="checkbox"/> Local funds affected <input checked="" type="checkbox"/> Substantial economic impact (≥\$1,000,000) <input checked="" type="checkbox"/> Approved by OSBM <input type="checkbox"/> No fiscal note required
<b>9. REASON FOR ACTION</b>	
<b>9A. What prompted this action? Check all that apply:</b> <input checked="" type="checkbox"/> Agency <input type="checkbox"/> Court order / cite: <input type="checkbox"/> Federal statute / cite: <input type="checkbox"/> Federal regulation / cite: <input type="checkbox"/> Legislation enacted by the General Assembly <input type="checkbox"/> Cite Session Law: <input type="checkbox"/> Petition for rule-making <input type="checkbox"/> Other:	
<b>9B. Explain:</b> This amendment is proposed to protect the public by updating the code to current standards of practice.  A fiscal note has been prepared per N.C.G.S. 143-138 (a1)(1) and was approved by OSBM on 8/21/23. OSBM has determined the amendments may have substantial economic impacts and impacts to local government with a potential for savings over time. No additional construction costs are anticipated for the commercial provisions. Increases in construction costs are anticipated for the residential provisions. The construction costs of dwellings regulated by this proposal exceeds \$80 per dwelling unit. State funds will not be affected. Local funds will be affected. Life-Cycle Cost savings are anticipated for both the commercial and residential provisions. A cost benefit analysis per N.C.G.S. 143-138 (a1)(2) has been prepared and was completed on 8/1/23.  The delayed effective date of this Rule is January 1, 2025. The Statutory authority for Rule-making is G. S. 143-136; 143-138.	

# SUBMISSION FOR PERMANENT RULE

10. Rulemaking Coordinator: David B. Rittlinger

David B. Rittlinger

Phone: (919)647-0008

E-Mail: david.rittlinger@ncdoi.gov

Additional agency contact, if any:

Phone:

E-Mail:

11. Signature of Agency Head\* or Rule-making Coordinator:



\*If this function has been delegated (reassigned) pursuant to G.S. 143B-10(a), submit a copy of the delegation with this form.

Typed Name: David B. Rittlinger

Title: Interim NCDOI-OSFM Deputy Commissioner of Engineering and Chief Code Consultant

## RRC AND OAH USE ONLY

Action taken:

- RRC extended period of review:
- RRC determined substantial changes:
- Withdrawn by agency
- Subject to Legislative Review
- Other:

Documents included:

1. Formatted Review Aide and 2024 North Carolina Energy Conservation Code: Chapter 1 through Appendices\*

TEXT THAT IS ~~STRUCK THROUGH~~ IS DELETED FROM THE 2018 EDITION TO CREATE THE 2024 EDITION.

TEXT THAT IS UNDERLINED IS NEW TEXT TO CREATE THE 2024 EDITION.

\*Of note, publishing edits to the Cover page, North Carolina Building Code Council members and committees lists, North Carolina Department of Insurance contact information, Preface, Table of Contents and Index are not included as those are publishing edits that do not contain permanent rule content. These publishing edits contain NCBCCC and NCDOI contact information, instructions on how to use the code, and guidance on where to find information in the code for the public-at-large. Coordination of the correct page numbers tied to the Table of Contents and Index cannot be accurately completed until the first draft of publishing is completed for NCDOI-OSFM Engineering & Codes staff review prior to completion of publishing by the International Code Council. NCDOI-OSFM Engineering & Codes staff will be coordinating the publication of all these publishing edits with the International Code Council once the proposed 2024 North Carolina Building Codes are approved.

2. Appendix C Code Change Proposal North Carolina Building Code Council (221213 Item B-6) 2024 North Carolina Energy Conservation Code (File: 2024 NCECC Proposed). A link to the petition can be found here: <https://www.ncosfm.gov/b-6-2024-ncecc-1>
3. 2017-2023 Approved Amendments to the 2018 North Carolina Energy Conservation Code (File: 2017-2023 Approved Amendments 230314-Energy Conservation Code). A link to these amendments can be found here: <https://www.ncosfm.gov/2017-2023-approved-amendments-230314energy-conservation-code-code>
4. Fiscal Note for the 2024 North Carolina Energy Conservation Code (File: BCC\_2023-08-21). A link to this fiscal note can be found here: <https://www.ncosfm.gov/b-6-2024-ncecc-fiscal-note>
5. 8/21/23 OSBM approval of fiscal note correspondence (Approval – 2024 Energy Conservation Code).
6. Cost Benefit Analysis for the 2024 North Carolina Energy Conservation Code (File: Building Code Council - 143-138(a1) Cost-Benefit Analysis for 2024 N.C. Energy Conservation Code). A link to this cost benefit analysis can be found here: <https://www.ncosfm.gov/b-6-2024-ncecc-cost-analysis>

# **SUBMISSION FOR PERMANENT RULE**

**(see attached documents)**

# CHAPTER 1 [CE] SCOPE AND ADMINISTRATION

## PART 1—SCOPE AND APPLICATION

### SECTION C101 SCOPE AND GENERAL REQUIREMENTS

**C101.1 Title.** ~~This code shall be known as the *North Carolina Energy Conservation Code* as adopted by the North Carolina Building Code Council on June 13, 2017 to be effective January 1, 2019. References to the *International Codes* shall mean the North Carolina Codes. The *North Carolina Energy Conservation Code* is referred to herein as “this code.” The North Carolina amendments to the *International Codes* are underlined. This code shall be known as the *Energy Conservation Code* of [NORTH CAROLINA], and shall be cited as such. It is referred to herein as “this code.”~~

**C101.2 Scope.** This code applies to *commercial buildings* and the buildings’ sites and associated systems and equipment.

**Exceptions:**

~~1. Energy expended in support of *process energy* applications does not invoke energy conservation code requirements or building thermal envelope requirements unless otherwise required in specific sections of this code.~~

~~2. Per G.S. 143-138 (b18), no energy conservation code provisions shall apply to any structure for which the primary occupancy classification is Group F, S, or U pursuant to Chapter 3 of the 2018 *North Carolina Building Code*. This exclusion shall apply to the entire building area.~~

**C101.3 Intent.** This code shall regulate the design and construction of buildings for the effective use and conservation of energy over the useful life of each building. This code is intended to provide flexibility to permit the use of innovative approaches and techniques to achieve this objective. This code is not intended to abridge safety, health or environmental requirements contained in other applicable codes or ordinances.

**C101.4 Applicability.** Where, in any specific case, different sections of this code specify different materials, methods of construction or other requirements, the most restrictive shall govern. Where there is a conflict between a general requirement and a specific requirement, the specific requirement shall govern.

~~**C101.4.1 Mixed occupancy.** Where a building includes both residential and *commercial* occupancies, each occupancy shall be separately considered and meet the applicable provisions of IECC—Commercial Provisions or IECC—Residential Provisions. **Mixed residential and commercial buildings.** Where a building includes both *residential building* and *commercial building* portions, each portion shall be separately considered and meet the applicable provisions of IECC—Commercial Provisions or IECC—Residential Provisions.~~

**C101.5 Compliance.** *Residential buildings* shall meet the provisions of IECC—Residential Provisions. *Commercial buildings* shall meet the provisions of IECC—Commercial Provisions.

**C101.5.1 Compliance materials.** The *code official* shall be permitted to approve specific computer software, worksheets, compliance manuals and other similar materials that meet the intent of this code.

~~**C101.5.2 Requirements of other State Agencies, occupational licensing boards, or commissions.** The North Carolina State Building Codes do not include all additional requirements for buildings and structures that may be imposed by other State agencies, occupational licensing boards, and commissions. It shall be the responsibility of a permit holder, design professional, contractor, or occupational license holder to determine whether any additional requirements exist.~~

**C101.6 Requirements of other State agencies, occupational licensing board or commissions.** -see the NC Administrative Code and Policies

### SECTION C102 ALTERNATIVE MATERIALS, DESIGN AND METHODS OF CONSTRUCTION AND EQUIPMENT

~~Deleted. See the *North Carolina Administrative Code and Policies*.~~

**C102.1 General.** The provisions of this code are not intended to prevent the installation of any material or to prohibit any design or method of construction not specifically prescribed by this code, provided that any such alternative has been approved. The code official shall have the authority to approve an alternative material, design or method of construction upon the written application of the owner or the owner's authorized agent. The code official shall first find that the proposed design is satisfactory and complies with the intent of the provisions of this code, and that the material, method or work offered is, for the purpose intended, not less than the equivalent of that prescribed in this code in quality, strength, effectiveness, fire resistance, durability, energy conservation and safety. The code official shall respond to the applicant, in writing, stating the reasons why the alternative was approved or was not approved.

**C102.1.1 Above code programs.** The code official or other authority having jurisdiction shall be permitted to deem a national, state or local energy efficiency program as exceeding the energy efficiency required by this code. Buildings approved in writing by such an energy efficiency program shall be considered to be in compliance with this code. The requirements identified in Table C407.2 shall be met.

## PART 2—ADMINISTRATION AND ENFORCEMENT

See the North Carolina Administrative Code and Policies for the administration and enforcement of the North Carolina State Building Codes as adopted by the Building Code Council and enforced by State and local code enforcement officials.

### SECTION C103 CONSTRUCTION DOCUMENTS

**C103.1 General.** Construction documents and other supporting data shall be submitted in one or more sets, or in a digital format where allowed by the building official, with each application for a permit. The construction documents shall be prepared by a registered design professional where required by the statutes of the jurisdiction in which the project is to be constructed. Where special conditions exist, the *code official* is authorized to require necessary construction documents to be prepared by a registered design professional.

**Exception:** The *code official* is authorized to waive the requirements for construction documents or other supporting data if the *code official* determines they are not necessary to confirm compliance with this code.

**C103.2 Information on construction documents.** Construction documents shall be drawn to scale on suitable material. Electronic media documents are permitted to be submitted where *approved* by the *code official*. Construction documents shall be of sufficient clarity to indicate the location, nature and extent of the work proposed, and show in sufficient detail pertinent data and features of the building, systems and equipment as herein governed. Details shall include, but are not limited to, the following as applicable:

- ~~1. Insulation materials and their R values.~~
- ~~2. Fenestration U factors and solar heat gain coefficients (SHGCs).~~
- ~~3. Area weighted U factor and solar heat gain coefficient (SHGC) calculations.~~
- ~~4. Mechanical system design criteria.~~
- ~~5. Mechanical and service water heating system and equipment types, sizes and efficiencies.~~
- ~~6. Economizer description.~~
- ~~7. Equipment and system controls.~~
- ~~8. Fan motor horsepower (hp) and controls.~~
- ~~9. Duct sealing, duct and pipe insulation and location.~~
- ~~10. Lighting fixture schedule with wattage and control narrative.~~
- ~~11. Deleted.~~
- ~~12. Air sealing details.~~

1. Energy compliance path.
2. Insulation materials and their  $R$ -values.
3. Fenestration  $U$ -factors and solar heat gain coefficients (SHGCs).
4. Area-weighted  $U$ -factor and solar heat gain coefficient (SHGC) calculations.
5. Mechanical system design criteria.
6. Mechanical and service water-heating systems and equipment types, sizes and efficiencies.
7. Economizer description.
8. Equipment and system controls.
9. Fan motor horsepower (hp) and controls.
10. Duct sealing, duct and pipe insulation and location.
11. Lighting fixture schedule with wattage and control narrative.
12. Location of *daylight* zones on floor plans.
13. Air barrier and air sealing details, including the location of the air barrier.

**C103.2.1 Building thermal envelope depiction.** ~~The *building's thermal envelope* shall be identified on the construction drawings.~~ The *building thermal envelope* shall be represented on the construction drawings.

**C103.3 Examination of documents.** ~~Deleted. See the *North Carolina Administrative Code and Policies*.~~ The *code official* shall examine or cause to be examined the accompanying construction documents and shall ascertain whether the construction indicated and described is in accordance with the requirements of this code and other pertinent laws or ordinances. The *code official* is authorized to utilize a registered design professional, or other *approved* entity not affiliated with the building design or construction, in conducting the review of the plans and specifications for compliance with the code.

**C103.3.1 Approval of construction documents.** When the *code official* issues a permit where construction documents are required, the construction documents shall be endorsed in writing and stamped "Reviewed for Code Compliance." Such *approved* construction documents shall not be changed, modified or altered without authorization from the *code official*. Work shall be done in accordance with the *approved* construction documents.

One set of construction documents so reviewed shall be retained by the *code official*. The other set shall be returned to the applicant, kept at the site of work and shall be open to inspection by the *code official* or a duly authorized representative.

**C103.3.2 Previous approvals.** This code shall not require changes in the construction documents, construction or designated occupancy of a structure for which a lawful permit has been heretofore issued or otherwise lawfully authorized, and the construction of which has been pursued in good faith within 180 days after the effective date of this code and has not been abandoned.

**C103.3.3 Phased approval.** The *code official* shall have the authority to issue a permit for the construction of part of an energy conservation system before the construction documents for the entire system have been submitted or *approved*, provided that adequate information and detailed statements have been filed complying with all pertinent requirements of this code. The holders of such permit shall proceed at their own risk without assurance that the permit for the entire energy conservation system will be granted.

**C103.4 Amended construction documents.** Changes made during construction that are not in compliance with the *approved* construction documents shall be resubmitted for approval as an amended set of construction documents.

**C103.5 Retention of construction documents.** One set of *approved* construction documents shall be retained by the *code official* for a period of not less than 180 days from date of completion of the permitted work, or as required by state or local laws.

**C103.6 Building documentation and closeout submittal requirements.** The construction documents shall specify that the documents described in this section be provided to the building owner or owner's authorized agent within 90 days of the date of receipt of the certificate of occupancy.

**C103.6.1 Record documents.** Construction documents shall be updated to convey a record of the completed work. Such updates shall include mechanical, electrical and control drawings that indicate all changes to size, type and location of components, equipment and assemblies.

**C103.6.2 Compliance documentation.** Energy code compliance documentation and supporting calculations shall be delivered in one document to the building owner as part of the project record documents or manuals, or as a standalone document. This document shall include the specific energy code edition utilized for compliance determination for each system,

documentation demonstrating compliance with Section C303.1.3 for each fenestration product installed, and the interior lighting power compliance path, building area or space-by-space, used to calculate the lighting power allowance.

For projects complying with Item 2 of Section C401.2, the documentation shall include:

1. The envelope insulation compliance path.
2. All compliance calculations including those required by Sections C402.1.5, C403.8.1, C405.3 and C405.5.

For projects complying with Section C407, the documentation shall include that required by Sections C407.3.1 and C407.3.2.

**C103.6.3 Systems operation control.** Training shall be provided to those responsible for maintaining and operating equipment included in the manuals required by Section C103.6.2.

The training shall include:

1. Review of manuals and permanent certificate.
2. Hands-on demonstration of all normal maintenance procedures, normal operating modes, and all emergency shutdown and startup procedures.
3. Training completion report.

## **SECTION C104** **INSPECTIONS FEES**

~~Deleted. See the North Carolina Administrative Code and Policies.~~

~~Deleted~~

## **SECTION C105** **VALIDITY INSPECTIONS**

~~Deleted. See the North Carolina Administrative Code and Policies.~~

**C105.1 C104.1 General.** Construction or work for which a permit is required shall be subject to inspection by the code official, his or her designated agent or an *approved agency*, and such construction or work shall remain visible and able to be accessed for inspection purposes until *approved*. Approval as a result of an inspection shall not be construed to be an approval of a violation of the provisions of this code or of other ordinances of the jurisdiction. Inspections presuming to give authority to violate or cancel the provisions of this code or of other ordinances of the jurisdiction shall not be valid. It shall be the duty of the permit applicant to cause the work to remain visible and able to be accessed for inspection purposes. Neither the code official nor the jurisdiction shall be liable for expense entailed in the removal or replacement of any material, product, system or building component required to allow inspection to validate compliance with this code.

**C105.2 C104.2 Required inspections.** The *code official*, his or her designated agent or an *approved agency*, upon notification, shall make the inspections set forth in Sections **C105.2.4 C104.2.1** through **C105.2.6 C104.2.6**.

**C105.2.1 C104.2.1 Footing and foundation insulation.** Inspections shall verify the footing and foundation insulation *R*-value, location, thickness, depth of burial and protection of insulation as required by the code, *approved* plans and specifications.

**C105.2.2 C104.2.2 Thermal envelope.** Inspections shall verify the correct type of insulation, *R*-values, location of insulation, fenestration, *U*-factor, SHGC and VT, and that air leakage controls are properly installed, as required by the code, *approved* plans and specifications.

**C105.2.3C104.2.3 Plumbing system.** Inspections shall verify the type of insulation, *R*-values, protection required, controls and heat traps as required by the code, *approved* plans and specifications.

**C105.2.4C104.2.4 Mechanical system.** Inspections shall verify the installed HVAC equipment for the correct type and size, controls, insulation, *R*-values, system and damper air leakage, minimum fan efficiency, energy recovery and economizer as required by the code, *approved* plans and specifications.

**C105.2.5C104.2.5 Electrical system.** Inspections shall verify lighting system controls, components and meters as required by the code, *approved* plans and specifications.

**C105.2.6C104.2.6 Final inspection.** The final inspection shall include verification of the installation and proper operation of all required building controls, and documentation verifying activities associated with required *building commissioning* have been conducted in accordance with Section C408.

**C105.3C104.3 Reinspection.** A building shall be reinspected where determined necessary by the *code official*.

**C105.4C104.4 Approved inspection agencies.** The *code official* is authorized to accept reports of third-party inspection agencies not affiliated with the building design or construction, provided that such agencies are *approved* as to qualifications and reliability relevant to the building components and systems that they are inspecting.

**C105.5C104.5 Inspection requests.** It shall be the duty of the holder of the permit or their duly authorized agent to notify the *code official* when work is ready for inspection. It shall be the duty of the permit holder to provide access to and means for inspections of such work that are required by this code.

**C105.6C104.6 Reinspection and testing.** Where any work or installation does not pass an initial test or inspection, the necessary corrections shall be made to achieve compliance with this code. The work or installation shall then be resubmitted to the *code official* for inspection and testing.

## SECTION **C406C105** REFERENCED STANDARDSNOTICE OF APPROVAL

**C106.1C105.1 Approval.** After the prescribed tests and inspections indicate that the work complies in all respects with this code, a notice of approval shall be issued by the *code official*.

**C106.2C105.2 Revocation.** The *code official* is authorized to suspend or revoke, in writing, a notice of approval issued under the provisions of this code wherever the certificate is issued in error, or on the basis of incorrect information supplied, or where it is determined that the *building* or structure, premise, or portion thereof is in violation of any ordinance or regulation or any of the provisions of this code.

## SECTION **C407C106** FEESVALIDITY

Deleted. See the *North Carolina Administrative Code and Policies*.

**C107.1C106.1 General.** If a portion of this code is held to be illegal or void, such a decision shall not affect the validity of the remainder of this code.

## SECTION **C408C107** STOP WORK ORDERREFERENCED STANDARDS

Deleted. See the *North Carolina Administrative Code and Policies*.

**C106.1C108.1C107.1 Referenced codes and standards.** The codes and standards referenced in this code shall be those listed in Chapter 6, and such codes and standards shall be considered as part of the requirements of this code to the prescribed extent of each such reference and as further regulated in Sections C106.1.1C108.1.1C107.1.1 and C106.1.2C108.1.2C107.2.2.

**C106.1.1C108.1.1C107.1.1 Conflicts.** Where conflicts occur between provisions of this code and referenced codes and standards, the provisions of this code shall apply.



~~C106.1.2~~~~C108.1.2~~~~C107.1.2~~ **Provisions in referenced codes and standards.** Where the extent of the reference to a referenced code or standard includes subject matter that is within the scope of this code, the provisions of this code, as applicable, shall take precedence over the provisions in the referenced code or standard.

~~C106.2~~~~C108.2~~~~C107.2~~ **Applications of references.** References to chapter or section numbers, or to provisions not specifically identified by number, shall be construed to refer to such chapter, section or provision of this code.

~~C106.3~~~~C108.3~~~~C107.3~~ **Other laws.** The provisions of this code shall not be deemed to nullify any provisions of local, state or federal law.

## **SECTION ~~C109~~C108** **BOARD OF APPEALS ~~STOP WORK ORDER~~**

~~Deleted. See the North Carolina Administrative Code and Policies.~~

~~C109.1~~~~C108.1~~ **Authority.** Where the *code official* finds any work regulated by this code being performed in a manner contrary to the provisions of this code or in a dangerous or unsafe manner, the *code official* is authorized to issue a stop work order.

~~C109.2~~~~C108.2~~ **Issuance.** The stop work order shall be in writing and shall be given to the owner of the property, the owner's authorized agent or the person performing the work. Upon issuance of a stop work order, the cited work shall immediately cease. The stop work order shall state the reason for the order and the conditions under which the cited work is authorized to resume.

~~C109.3~~~~C108.3~~ **Emergencies.** Where an emergency exists, the *code official* shall not be required to give a written notice prior to stopping the work.

~~C109.4~~~~C108.4~~ **Failure to comply.** Any person who shall continue any work after having been served with a stop work order, except such work as that person is directed to perform to remove a violation or unsafe condition, shall be subject to fines established by the authority having jurisdiction.

## **SECTION ~~C110~~C109** **BOARD OF APPEALS**

~~C110.1~~~~C109.1~~ **General.** In order to hear and decide appeals of orders, decisions or determinations made by the *code official* relative to the application and interpretation of this code, there shall be and is hereby created a board of appeals. The *code official* shall be an ex officio member of said board but shall not have a vote on any matter before the board. The board of appeals shall be appointed by the governing body and shall hold office at its pleasure. The board shall adopt rules of procedure for conducting its business, and shall render all decisions and findings in writing to the appellant with a duplicate copy to the *code official*.

~~C110.2~~~~C109.2~~ **Limitations on authority.** An application for appeal shall be based on a claim that the true intent of this code or the rules legally adopted thereunder have been incorrectly interpreted, the provisions of this code do not fully apply or an equally good or better form of construction is proposed. The board shall not have authority to waive requirements of this code.

~~C110.3~~~~C109.3~~ **Qualifications.** The board of appeals shall consist of members who are qualified by experience and training and are not employees of the jurisdiction.

## CHAPTER 2 [CE] DEFINITIONS

### SECTION C201 GENERAL

**C201.1 Scope.** Unless stated otherwise, the following words and terms in this code shall have the meanings indicated in this chapter.

**C201.2 Interchangeability.** Words used in the present tense include the future; words in the masculine gender include the feminine and neuter; the singular number includes the plural and the plural includes the singular.

**C201.3 Terms defined in other codes.** Terms that are not defined in this code but are defined in the *International Building Code*, *International Fire Code*, *International Fuel Gas Code*, *International Mechanical Code*, *International Plumbing Code* or the *International Residential Code* shall have the meanings ascribed to them in those codes.

**C201.4 Terms not defined.** Terms not defined by this chapter shall have ordinarily accepted meanings such as the context implies.

### SECTION C202 GENERAL DEFINITIONS

**ABOVE-GRADE WALL.** See “*Wall, above-grade.*”

~~**ACCESSIBLE.** Admitting close approach as a result of not being guarded by locked doors, elevation or other effective means (see “*Readily accessible.*”).~~

**ACCESS (TO).** That which enables a device, appliance or equipment to be reached by *ready access* or by a means that first requires the removal or movement of a panel or similar obstruction.

~~**ACH75.** Air Changes per Hour of measured airflow in relation to the building volume while the building is maintained at a pressure difference of 75 pascals (0.30 in wg).~~

~~**ADDITION.** An extension or increase in the *conditioned space* floor area or height of a building or structure. An extension or increase in the *conditioned space* floor area, number of stories or height of a building or structure.~~

~~**AIR BARRIER.** Materials assembled and joined together to provide a barrier to air leakage through the building envelope. An air barrier may be a single material or a combination of materials. One or more materials joined together in a continuous manner to restrict or prevent the passage of air through the *building thermal envelope* and its assemblies.~~

**AIR CURTAIN.** A device, installed at the *building entrance*, that generates and discharges a laminar air stream intended to prevent the infiltration of external, unconditioned air into the conditioned spaces, or the loss of interior, conditioned air to the outside.

~~**AIR IMPERMEABLE INSULATION.** An insulation having an air permeance equal to or less than 0.02 L/s m<sup>2</sup> at 75 Pa pressure differential tested according to ASTM E2178 or E283 at the thickness applied.~~

~~**ALTERATION.** Any construction, retrofit or renovation to an existing structure other than repair or addition. addition that requires a permit. Also, a change in a building, electrical, gas, mechanical or plumbing system that involves an extension, addition or change to the arrangement, type or purpose of the original installation. installation that requires a permit.~~

~~**APPROVED.** Acceptable to the code official for compliance with the provisions of the applicable code or referenced standard. Acceptable to the code official.~~

~~**APPROVED AGENCY.** An established and recognized agency regularly engaged in conducting tests or furnishing inspection services, when such agency has been approved by the *code official*. An established and recognized agency that is regularly engaged in conducting tests or furnishing inspection services, or furnishing product certification, where such agency has been approved by the *code official*.~~

**AUTOMATIC.** Self-acting, operating by its own mechanism when actuated by some impersonal influence, as, for example, a change in current strength, pressure, temperature or mechanical configuration (see “*Manual.*”).

**BELOW-GRADE WALL.** See “*Wall, below-grade.*”

**BIOGAS.** A mixture of hydrocarbons that is a gas at 60°F (15.5°C) and 1 atmosphere of pressure that is produced through the anaerobic digestion of organic matter.

**BIOMASS.** Nonfossilized and biodegradable organic material originating from plants, animals and/or microorganisms, including products, by-products, residues and waste from agriculture, forestry and related industries as well as the nonfossilized and biodegradable organic fractions of industrial and municipal wastes, including gases and liquids recovered from the decomposition of nonfossilized and biodegradable organic material.

**BOILER, MODULATING.** A boiler that is capable of more than a single firing rate in response to a varying temperature or heating load.

**BOILER SYSTEM.** One or more boilers, their piping and controls that work together to supply steam or hot water to heat output devices remote from the boiler.

**BUBBLE POINT.** The refrigerant liquid saturation temperature at a specified pressure.

**BUILDING.** Any structure used or intended for supporting or sheltering any use or ~~occupancy~~ occupancy, including any mechanical systems, service water-heating systems and electric power and lighting systems located on the building site and supporting the building.

**BUILDING COMMISSIONING.** A process that verifies and documents that the selected building systems have been designed, installed and function according to the owner's project requirements and construction documents, and to minimum code requirements.

**BUILDING ENTRANCE.** Any door, set of doors, doorway or other form of portal that is used to gain access to the building from the outside by the public.

**BUILDING SITE.** A contiguous area of land that is under the ownership or control of one entity.

**BUILDING THERMAL ENVELOPE.** ~~The walls, below grade, exterior walls, floor, roof and any other building elements that enclose conditioned space or provide a boundary between conditioned space and exempt or unconditioned space. The basement walls, exterior walls, floors, ceilings, roofs and any other building element assemblies that enclose conditioned space or provide a boundary between conditioned space and exempt or unconditioned space.~~

**CAPTIVE KEY OVERRIDE.** A lighting control that will not release the key that activates the override when the lighting is on.

**CAVITY INSULATION.** Insulating material located between framing members.

**C-FACTOR (THERMAL CONDUCTANCE).** The coefficient of heat transmission (surface to surface) through a building component or assembly, equal to the time rate of heat flow per unit area and the unit temperature difference between the warm side and cold side surfaces (Btu/h × ft<sup>2</sup> × °F) [W/(m<sup>2</sup> × K)].

**CHANGE OF OCCUPANCY.** A change in the use of a building or a portion of a building that results in any of the following:

1. A change of occupancy classification.
2. A change from one group to another group within an occupancy classification.
3. Any change in use within a group for which there is a change in the application of the requirements of this code.

**CIRCULATING HOT WATER SYSTEM.** A specifically designed water distribution system where one or more pumps are operated in the service hot water piping to circulate heated water from the water-heating equipment to the fixture supply and back to the water-heating equipment.

**CLIMATE ZONE.** A geographical region based on climatic criteria as specified in this code.

**CODE OFFICIAL.** The officer or other designated authority charged with the administration and enforcement of this code, or a duly authorized representative.

**COEFFICIENT OF PERFORMANCE (COP) – COOLING.** ~~The ratio of the rate of heat input, in consistent units, for a complete refrigerating system or some specific portion of that system under designated operating conditions. The ratio of the rate of heat removal to the rate of energy input, in consistent units, for a complete refrigerating system or some specific portion of that system under designated operating conditions.~~

**COEFFICIENT OF PERFORMANCE (COP) – HEATING.** The ratio of the rate of heat delivered to the rate of energy input, in consistent units, for a complete heat pump system, including the compressor and, if applicable, auxiliary heat, under designated operating conditions.

**COMMERCIAL BUILDING.** For this code, all buildings that are not included in the definition of “*Residential building.*”

**COMPUTER ROOM.** ~~A room whose primary function is to house equipment for the processing and storage of electronic data and that has a design electronic data equipment power density exceeding 20 watts per square foot of conditioned floor area.~~ A room whose primary function is to house equipment for the processing and storage of electronic data which has a design total information technology equipment (ITE) equipment power density less than or equal to 20 watts per square foot (20 watts per 0.092 m<sup>2</sup>) of conditioned area or a design total ITE equipment load less than or equal to 10 kW.

**CONDENSING UNIT.** A factory-made assembly of refrigeration components designed to compress and liquefy a specific refrigerant. The unit consists of one or more refrigerant compressors, refrigerant condensers (air-cooled, evaporatively cooled or water-cooled), condenser fans and motors (where used) and factory-supplied accessories.

**CONDITIONED FLOOR AREA.** The horizontal projection of the floors associated with the *conditioned space*.

**CONDITIONED SPACE.** ~~A space within a building that is provided with heating or cooling equipment or systems capable of maintaining, through design or heat loss/gain, 50°F (10°C) during the heating season or 85°F (29°C) during the cooling season, or communicates directly with a conditioned space. Spaces within the building thermal envelope are considered conditioned space.~~ An area, room or space that is enclosed within the *building thermal envelope* and is directly or indirectly heated or cooled. Spaces are indirectly heated or cooled where they communicate through openings with conditioned spaces, where they are separated from conditioned spaces by uninsulated walls, floors or ceilings, or where they contain uninsulated ducts, piping or other sources of heating or cooling.

**CONTINUOUS AIR BARRIER.** ~~A combination of materials and assemblies that restrict or prevent the passage of air through the building thermal envelope.~~

**CONTINUOUS INSULATION (ci).** Insulating material that is continuous across all structural members without thermal bridges other than fasteners and service openings. It is installed on the interior or exterior or is integral to any opaque surface of the building envelope.

**CRAWL SPACE WALL.** The opaque portion of a wall that encloses a crawl space and is partially or totally below grade.

**CURTAIN WALL.** Fenestration products used to create an external nonload-bearing wall that is designed to separate the exterior and interior environments.

**DATA CENTER.** A room or series of rooms that share data center systems, whose primary function is to house equipment for the processing and storage of electronic data and that has a design total ITE equipment power density exceeding 20 watts per square foot (20 watts per 0.092 m<sup>2</sup>) of conditioned area and a total design ITE equipment load greater than 10 kW.

**DATA CENTER SYSTEMS.** HVAC systems and equipment, or portions thereof, used to provide cooling or ventilation in a data center.

**DAYLIGHT RESPONSIVE CONTROL.** A device or system that provides automatic control of electric light levels based on the amount of daylight in a space.

**DAYLIGHT ZONE.** That portion of a building’s interior floor area that is illuminated by natural light.

**DEMAND CONTROL VENTILATION (DCV).** A ventilation system capability that provides for the automatic reduction of outdoor air intake below design rates when the actual occupancy of spaces served by the system is less than design occupancy.

**DEMAND RECIRCULATION WATER SYSTEM.** A water distribution system where one or more pumps prime the service hot water piping with heated water upon a demand for hot water.

**DIRECT DIGITAL CONTROL (DDC).** A type of control where controlled and monitored analog or binary data, such as temperature and contact closures, are converted to digital format for manipulation and calculations by a digital computer or microprocessor, then converted back to analog or binary form to control physical devices.

**DUCT.** A tube or conduit utilized for conveying air. The air passages of self-contained systems are not to be construed as air ducts.

**DUCT SYSTEM.** A continuous passageway for the transmission of air that, in addition to ducts, includes duct fittings, dampers, plenums, fans and accessory air-handling equipment and appliances.

**DWELLING UNIT.** A single unit providing complete independent living facilities for one or more persons, including permanent provisions for living, sleeping, eating, cooking and sanitation.

**DYNAMIC GLAZING.** Any fenestration product that has the fully reversible ability to change its performance properties, including *U*-factor, solar heat gain coefficient (SHGC) or visible transmittance (VT).

**ECONOMIZER, AIR.** A duct and damper arrangement and automatic control system that allows a cooling system to supply outside air to reduce or eliminate the need for mechanical cooling during mild or cold weather.

**ECONOMIZER, WATER.** A system where the supply air of a cooling system is cooled indirectly with water that is itself cooled by heat or mass transfer to the environment without the use of mechanical cooling.

**ENCLOSED SPACE.** A volume surrounded by solid surfaces such as walls, floors, roofs and operable devices, such as doors and operable windows.

**ENERGY ANALYSIS.** A method for estimating the annual energy use of the *proposed design* and *standard reference design* based on estimates of energy use.

**ENERGY COST.** The total estimated annual cost for purchased energy for the building functions regulated by this code, including applicable demand charges.

**ENERGY RECOVERY VENTILATION SYSTEM.** Systems that employ air-to-air heat exchangers to recover energy from exhaust air for the purpose of preheating, precooling, humidifying or dehumidifying outdoor ventilation air prior to supplying the air to a space, either directly or as part of an HVAC system.

**ENERGY SIMULATION TOOL.** An *approved* software program or calculation-based methodology that projects the annual energy use of a building.

**ENTHALPY RECOVERY RATIO.** Change in the enthalpy of the outdoor air supply divided by the difference between the outdoor air and entering exhaust air enthalpy, expressed as a percentage.

**ENTRANCE DOOR.** ~~Fenestration products used for ingress, egress and access in nonresidential buildings, including, but not limited to, exterior entrances that utilize latching hardware and automatic closers and contain over 50 percent glass specifically designed to withstand heavy use and possibly abuse.~~ A vertical fenestration product used for occupant ingress, egress and access in nonresidential buildings, including, but not limited to, exterior entrances utilizing latching hardware and automatic closers and containing over 50 percent glazing specifically designed to withstand heavy-duty usage.

**EQUIPMENT ROOM.** A space that contains either electrical equipment, mechanical equipment, machinery, water pumps or hydraulic pumps that are a function of the building's services.

**EXTERIOR WALL.** ~~Walls including both above-grade walls and walls, below-grade.~~ Walls including both above-grade walls and basement walls.

**FAN, EMBEDDED.** A fan that is part of a manufactured assembly where the assembly includes functions other than air movement.

**FAN ARRAY.** Multiple fans in parallel between two plenum sections in an air distribution system.

**FAN BRAKE HORSEPOWER (BHP).** The horsepower delivered to the fan's shaft. Brake horsepower does not include the mechanical drive losses, such as that from belts and gears.

**FAN ENERGY INDEX (FEI).** The ratio of the electric input power of a reference fan to the electric input power of the actual fan as calculated in accordance with AMCA 208.

**FAN NAMEPLATE ELECTRICAL INPUT POWER.** The nominal electrical input power rating stamped on a fan assembly nameplate.

**FAN SYSTEM DESIGN CONDITIONS.** ~~Operating conditions that can be expected to occur during normal system operation that result in the highest supply fan airflow rate to conditioned spaces served by the system.~~ Operating conditions that can be expected to occur during normal system operation that result in the highest supply fan airflow rate to conditioned spaces served by the system, other than during air economizer operation.

**FAN SYSTEM ELECTRICAL INPUT POWER.** The sum of the fan electrical power of all fans that are required to operate at fan system design conditions to supply air from the heating or cooling source to the conditioned spaces and/or return it to the source or exhaust it to the outdoors.

**FAN SYSTEM MOTOR NAMEPLATE HP.** The sum of the motor nameplate horsepower of all fans that are required to operate at design conditions to supply air from the heating or cooling source to the *conditioned spaces* and return it to the source or exhaust it to the outdoors.

**FAULT DETECTION AND DIAGNOSTICS (FDD) SYSTEM.** A software platform that utilizes building analytic algorithms to convert data provided by sensors and devices to automatically identify faults in building systems and provide a prioritized list of actionable resolutions to those faults based on cost or energy avoidance, comfort and maintenance impact.

**FENESTRATION.** Products classified as either vertical fenestration or skylights. Products classified as either skylights or vertical fenestration.

~~Skylight.~~ Glass or other transparent or translucent glazing material installed at a slope of less than 60 degrees (1.05 rad) from horizontal. **Skylights.** Glass or other transparent or translucent glazing material installed at a slope of less than 60 degrees (1.05 rad) from horizontal, including unit skylights, tubular daylighting devices and glazing materials in solariums, sunrooms, roofs, greenhouses and sloped walls.

~~Vertical fenestration.~~ Windows (fixed or moveable), opaque doors, glazed doors, glazed block and combination opaque/glazed doors composed of glass or other transparent or translucent glazing materials and installed at a slope of at least 60 degrees (1.05 rad) from horizontal. Windows that are fixed or operable, opaque doors, glazed doors, glazed block and combination opaque and glazed doors composed of glass or other transparent or translucent glazing materials and installed at a slope of not less than 60 degrees (1.05 rad) from horizontal.

**FENESTRATION PRODUCT, FIELD-FABRICATED.** A fenestration product whose frame is made at the construction site of standard dimensional lumber or other materials that were not previously cut or otherwise formed with the specific intention of being used to fabricate a fenestration product or exterior door. Field-fabricated does not include site-built fenestration.

**FENESTRATION PRODUCT, SITE-BUILT.** A fenestration designed to be made up of field-glazed or field-assembled units using specific factory cut or otherwise factory-formed framing and glazing units. Examples of site-built fenestration include storefront systems, curtain walls and atrium roof systems.

**F-FACTOR.** The perimeter heat loss factor for slab-on-grade floors (Btu/h × ft × °F) [W/(m × K)].

**FLOOR AREA, NET.** The actual occupied area not including unoccupied accessory areas such as corridors, stairways, toilet rooms, mechanical rooms and closets.

~~GENERAL LIGHTING.~~ Lighting that provides a substantially uniform level of illumination throughout an area. General lighting shall not include decorative lighting or lighting that provides a dissimilar level of illumination to serve a specialized application or feature within such area. **Interior lighting that provides a substantially uniform level of illumination throughout a space.**

**GENERAL PURPOSE ELECTRIC MOTOR (SUBTYPE I).** A motor that is designed in standard ratings with either of the following:

- ~~1. Standard operating characteristics and standard mechanical construction for use under usual service conditions, such as those specified in NEMA MG1, paragraph 14.02, "Usual Service Conditions," and without restriction to a particular application or type of application.~~
- ~~2. Standard operating characteristics or standard mechanical construction for use under unusual service conditions, such as those specified in NEMA MG1, paragraph 14.03, "Unusual Service Conditions," or for a particular type of application, and that can be used in most general purpose applications.~~

~~General purpose electric motors (Subtype I) are constructed in NEMA T-frame sizes or IEC metric equivalent, starting at 143T.~~

**GENERAL PURPOSE ELECTRIC MOTOR (SUBTYPE II).** A motor incorporating the design elements of a general purpose electric motor (Subtype I) that is configured as one of the following:

- ~~1. A U frame motor.~~
- ~~2. A Design C motor.~~
- ~~3. A close coupled pump motor.~~
- ~~4. A footless motor.~~
- ~~5. A vertical, solid shaft, normal thrust motor (as tested in a horizontal configuration).~~
- ~~6. An 8 pole motor (900 rpm).~~
- ~~7. A polyphase motor with voltage of not more than 600 volts (other than 230 or 460 volts).~~

**GREENHOUSE.** ~~A structure or a thermally isolated area of a building that maintains a specialized sunlit environment exclusively used for, and essential to, the cultivation, protection or maintenance of plants. A structure or a thermally isolated area of a building that maintains a specialized sunlit environment exclusively used for, and essential to, the cultivation, protection or maintenance of plants. Greenhouses are those that are erected for a period of 180 days or more.~~

**GROUP R.** Buildings or portions of buildings that contain any of the following occupancies as established in the *International Building Code*:

1. Group R-1.
2. Group R-2 where located more than three stories in height above grade plane.
3. Group R-4 where located more than three stories in height above grade plane.

**HEAT TRAP.** An arrangement of piping and fittings, such as elbows, or a commercially available heat trap that prevents thermosyphoning of hot water during standby periods.

**HEATED SLAB.** Slab-on-grade construction in which the heating elements, hydronic tubing or hot air distribution system is in contact with, or placed within or under, the slab.

**HIGH SPEED DOOR.** A nonswinging door used primarily to facilitate vehicular access or material transportation, with a minimum opening rate of 32 inches (813 mm) per second, a minimum closing rate of 24 inches (610 mm) per second and that includes an automatic-closing device.

**HISTORIC BUILDING.** Any building or structure that is one or more of the following:

1. Listed, or certified as eligible for listing, by the State Historic Preservation Officer or the Keeper of the National Register of Historic Places, in the National Register of Historic Places.
2. Designated as historic under an applicable state or local law.
3. Certified as a contributing resource within a National Register-listed, state-designated or locally designated historic district.

~~**HUMIDISTAT.** A regulatory device, actuated by changes in humidity, used for automatic control of relative humidity.~~

**IEC DESIGN H MOTOR.** An electric motor that meets all of the following:

1. It is an induction motor designed for use with three-phase power.
2. It contains a cage rotor.
3. It is capable of direct-on-line starting.
4. It has four, six or eight poles.
5. It is rated from 0.4 kW to 1600 kW at a frequency of 60 hertz.

**IEC DESIGN N MOTOR.** An electric motor that meets all of the following:

1. It is an induction motor designed for use with three-phase power.
2. It contains a cage rotor.
3. It is capable of direct-on-line starting.
4. It has two, four, six or eight poles.
5. It is rated from 0.4 kW to 1600 kW at a frequency of 60 hertz.

**INFILTRATION.** The uncontrolled inward air leakage into a building caused by the pressure effects of wind or the effect of differences in the indoor and outdoor air density or both.

**INFORMATION TECHNOLOGY EQUIPMENT (ITE).** Items including computers, data storage devices, servers and network and communication equipment.

**INTEGRATED PART LOAD VALUE (IPLV).** A single-number figure of merit based on part-load EER, COP or kW/ton expressing part-load efficiency for air-conditioning and heat pump equipment on the basis of weighted operation at various load capacities for equipment.

**INTERNAL CURTAIN SYSTEM.** A system consisting of movable panels of fabric or plastic film used to cover and uncover the space enclosed in a *greenhouse* on a daily basis.

**ISOLATION DEVICES.** Devices that isolate HVAC zones so that they can be operated independently of one another. *Isolation devices* include separate systems, isolation dampers and controls providing shutoff at terminal boxes.

**LABELED.** ~~Appliances, equipment, materials or products to which have been affixed a label, seal, symbol or other identifying mark of a nationally recognized testing laboratory, inspection agency or other organization concerned with product evaluation that maintains periodic inspection of the production of the above labeled items and whose labeling indicates either that the appliances, equipment, material or product meets identified standards or has been tested and found suitable for a specified purpose.~~ Equipment, materials or products to which have been affixed a label, seal, symbol or other identifying mark of a nationally recognized testing laboratory, approved agency or other organization concerned with product evaluation that maintains periodic inspection of the production of the labeled items and whose labeling indicates either that the equipment, material or product meets identified standards or has been tested and found suitable for a specified purpose.

**LAMP.** The device in a lighting fixture that provides illumination, typically a bulb, fluorescent tube, or light emitting diode (LED).

**LARGE-DIAMETER CEILING FAN.** A ceiling fan that is greater than 7 feet (2134 mm) in diameter. These fans are sometimes referred to as High-Volume, Low-Speed (HVLS) fans.

**LINER SYSTEM (Ls).** A system that includes the following:

1. A continuous vapor barrier liner membrane that is installed below the purlins and that is uninterrupted by framing members.
2. An uncompressed, unfaced insulation resting on top of the liner membrane and located between the purlins.

For multilayer installations, the last rated *R*-value of insulation is for unfaced insulation draped over purlins and then compressed when the metal roof panels are attached.

**LISTED.** ~~Appliances, equipment, materials, products or services included in a list published by an organization acceptable to the code official and concerned with evaluation of products or services that maintains periodic inspection of production of listed equipment or materials or periodic evaluation of services and whose listing states either that the appliances, equipment, material, product or service meets identified standards or has been tested and found suitable for a specified purpose.~~ Equipment, materials, products or services included in a list published by an organization acceptable to the code official and concerned with evaluation of products or services that maintains periodic inspection of production of listed equipment or materials or periodic evaluation of services and whose listing states either that the equipment, material, product or service meets identified standards or has been tested and found suitable for a specified purpose.

**LOW-SLOPED ROOF.** A roof having a slope less than 2 units vertical in 12 units horizontal.

**LOW-VOLTAGE DRY-TYPE DISTRIBUTION TRANSFORMER.** A transformer that is air-cooled, does not use oil as a coolant, has an input voltage less than or equal to 600 volts and is rated for operation at a frequency of 60 hertz.

**LOW-VOLTAGE LIGHTING.** ~~Lighting equipment powered through a transformer such as a cable conductor, a rail conductor and track lighting.~~

**LUMINAIRE-LEVEL LIGHTING CONTROLS.** A lighting system consisting of one or more luminaires with embedded lighting control logic, occupancy and ambient light sensors, wireless networking capabilities and local override switching capability, where required.

**MANUAL.** Capable of being operated by personal intervention (see “Automatic”).

**NAMEPLATE HORSEPOWER.** ~~The nominal motor horse power rating stamped on the motor nameplate.~~ The nominal motor output power rating stamped on the motor nameplate.

**NEMA DESIGN A MOTOR.** A squirrel-cage motor that meets all of the following:

1. It is designed to withstand full-voltage starting and develop locked-rotor torque as shown in paragraph 12.38.1 of NEMA MG 1.
2. It has pull-up torque not less than the values shown in paragraph 12.40.1 of NEMA MG 1.
3. It has breakdown torque not less than the values shown in paragraph 12.39.1 of NEMA MG 1.
4. It has a locked-rotor current higher than the values shown in paragraph 12.35.1 of NEMA MG 1 for 60 hertz and paragraph 12.35.2 of NEMA MG 1 for 50 hertz.



5. It has a slip at rated load of less than 5 percent for motors with fewer than 10 poles.

**NEMA DESIGN B MOTOR.** A squirrel-cage motor that meets all of the following:

1. It is designed to withstand full-voltage starting.
2. It develops locked-rotor, breakdown and pull-up torques adequate for general application as specified in Sections 12.38, 12.39 and 12.40 of NEMA MG1.
3. It draws locked-rotor current not to exceed the values shown in Section 12.35.1 for 60 hertz and Section 12.35.2 for 50 hertz of NEMA MG1.
4. It has a slip at rated load of less than 5 percent for motors with fewer than 10 poles.

**NEMA DESIGN C MOTOR.** A squirrel-cage motor that meets all of the following:

1. Designed to withstand full-voltage starting and develop locked-rotor torque for high-torque applications up to the values shown in paragraph 12.38.2 of NEMA MG1 (incorporated by reference, see A§431.15).
2. It has pull-up torque not less than the values shown in paragraph 12.40.2 of NEMA MG1.
3. It has breakdown torque not less than the values shown in paragraph 12.39.2 of NEMA MG1.
4. It has a locked-rotor current not to exceed the values shown in paragraph 12.35.1 of NEMA MG1 for 60 hertz and paragraph 12.35.2 for 50 hertz.
5. It has a slip at rated load of less than 5 percent.

**NETWORKED GUESTROOM CONTROL SYSTEM.** A control system, with access from the front desk or other central location associated with a *Group R-1* building, that is capable of identifying the rented and unrented status of each guestroom according to a timed schedule, and is capable of controlling HVAC in each hotel and motel guestroom separately.

**NONSTANDARD PART LOAD VALUE (NPLV).** A single-number part-load efficiency figure of merit calculated and referenced to conditions other than IPLV conditions, for units that are not designed to operate at AHRI standard rating conditions.

**OCCUPANT SENSOR CONTROL.** An automatic control device or system that detects the presence or absence of people within an area and causes lighting, equipment or appliances to be regulated accordingly.

**ON-SITE RENEWABLE ENERGY.** ~~Includes solar photo-voltaic; active solar thermal that employs collection panels, heat transfer mechanical components; wind; small hydroelectric; tidal; wave energy; geothermal (core earth); biomass energy systems; landfill gas and bio-fuel based electrical production. On site energy shall be generated on or adjacent to the project site and shall not be delivered to the project through the utility service.~~ Energy from renewable energy resources harvested at the building project site.

**OPAQUE DOOR.** A door that is not less than 50-percent opaque in surface area.

**POWERED ROOF/WALL VENTILATORS.** A fan consisting of a centrifugal or axial impeller with an integral driver in a weather-resistant housing and with a base designed to fit, usually by means of a curb, over a wall or roof opening.

**PROCESS ENERGY.** ~~Energy consumed in support of manufacturing, industrial, or commercial processes other than conditioning spaces and maintaining comfort and amenities for the occupants of a building.~~

**PROPOSED DESIGN.** A description of the proposed building used to estimate annual energy use for determining compliance based on total building performance.

**RADIANT HEATING SYSTEM.** A heating system that transfers heat to objects and surfaces within a conditioned space, primarily by infrared radiation.

**READILY ACCESSIBLE.** ~~Capable of being reached quickly for operation, renewal or inspection without requiring those to whom ready access is requisite to climb over or remove obstacles or to resort to portable ladders or access equipment (see "Accessible").~~

**READY ACCESS (TO).** That which enables a device, appliance or equipment to be directly reached without requiring the removal or movement of any panel or similar obstruction.

**REFRIGERANT DEW POINT.** The refrigerant vapor saturation temperature at a specified pressure.

**REFRIGERATED WAREHOUSE COOLER.** An enclosed storage space capable of being refrigerated to temperatures above 32°F (0°C) that can be walked into and has a total chilled storage area of not less than 3,000 square feet (279 m<sup>2</sup>).

**REFRIGERATED WAREHOUSE FREEZER.** An enclosed storage space capable of being refrigerated to temperatures at or below 32°F (0°C) that can be walked into and has a total chilled storage area of not less than 3,000 square feet (279 m<sup>2</sup>).

**REFRIGERATION SYSTEM, LOW TEMPERATURE.** Systems for maintaining food product in a frozen state in refrigeration applications.

**REFRIGERATION SYSTEM, MEDIUM TEMPERATURE.** Systems for maintaining food product above freezing in refrigeration applications.

**REGISTERED DESIGN PROFESSIONAL.** An individual who is registered or licensed to practice their respective design profession as defined by the statutory requirements of the professional registration laws of the state or jurisdiction in which the project is to be constructed. Design by a registered design professional is not required where exempt under the registration or licensure laws. ~~An individual who is registered or licensed to practice their respective design profession as defined by the statutory requirements of the professional registration laws of the state or jurisdiction in which the project is to be constructed.~~

**RENEWABLE ENERGY RESOURCES.** Energy derived from solar radiation, wind, waves, tides, landfill gas, biogas, biomass or extracted from hot fluid or steam heated within the earth.

**REPAIR.** The reconstruction or renewal of any part of an existing building for the purpose of its maintenance or to correct damage.

**REROOFING.** The process of recovering or replacing an existing roof covering. See “*Roof recover*” and “*Roof replacement*.”

**RESIDENTIAL BUILDING.** For this code, includes detached one- and two-family dwellings and multiple single-family dwellings (townhouses) ~~as well as and~~ Group R-2, R-3 and R-4 buildings three stories or less in height above grade plane.

**ROOF ASSEMBLY.** A system designed to provide weather protection and resistance to design loads. The system consists of a roof covering and roof deck or a single component serving as both the roof covering and the roof deck. A roof assembly includes the roof covering, underlayment, roof deck, insulation, vapor retarder and interior finish.

**ROOF RECOVER.** The process of installing an additional roof covering over an existing roof covering without removing the existing roof covering.

**ROOF REPAIR.** Reconstruction or renewal of any part of an existing roof for the purpose of its maintenance.

**ROOF REPLACEMENT.** The process of removing the existing roof covering, repairing any damaged substrate and installing a new roof covering.

**ROOFTOP MONITOR.** A raised section of a roof containing vertical fenestration along one or more sides.

**R-VALUE (THERMAL RESISTANCE).** The inverse of the time rate of heat flow through a body from one of its bounding surfaces to the other surface for a unit temperature difference between the two surfaces, under steady state conditions, per unit area ( $h \times ft^2 \times ^\circ F/Btu$ ) [ $(m^2 \times K)/W$ ].

**SATURATED CONDENSING TEMPERATURE.** The saturation temperature corresponding to the measured refrigerant pressure at the condenser inlet for single component and azeotropic refrigerants, and the arithmetic average of the dew point and *bubble point* temperatures corresponding to the refrigerant pressure at the condenser entrance for zeotropic refrigerants.

**SCREW LAMP HOLDERS.** A lamp base that requires a screw-in type lamp, such as a compact fluorescent, incandescent or tungsten-halogen bulb.

**SERVICE WATER HEATING.** Supply of hot water for purposes other than comfort heating.

**SHADING COEFFICIENT.** The amount of the sun’s heat transmitted through a given window compared with that of a standard  $\frac{1}{8}$ -inch-thick single pane of glass under the same conditions.

**SITE RECOVERED ENERGY.** Waste energy recovered at the building site that is used to off set consumption of purchased fuel or electrical energy supplies.

**SLEEPING UNIT.** A room or space in which people sleep ~~which that~~ can also include permanent provisions for living, eating, and either sanitation or kitchen facilities but not both. Such rooms and spaces that are also part of a dwelling unit are not *sleeping units*.

**SMALL ELECTRIC MOTOR.** A general purpose alternating-current single-speed induction motor.

~~**SOLAR ENERGY SOURCE.** Source of thermal, chemical, or electrical energy derived from direct conversion of incident solar radiation at the building site.~~

**SOLAR HEAT GAIN COEFFICIENT (SHGC).** The ratio of the solar heat gain entering the space through the fenestration assembly to the incident solar radiation. Solar heat gain includes directly transmitted solar heat and absorbed solar radiation ~~which~~that is then reradiated, conducted or convected into the space.

**STANDARD REFERENCE DESIGN.** A version of the *proposed design* that meets the minimum requirements of this code and is used to determine the maximum annual energy use requirement for compliance based on total building performance.

~~**STOREFRONT.** A nonresidential system of doors and windows mullied as a composite fenestration structure that has been designed to resist heavy use. *Storefront* systems include, but are not limited to, exterior fenestration systems that span from the floor level or above to the ceiling of the same story on commercial buildings, with or without mullied windows and doors.~~  
A system of doors and windows mullied as a composite fenestration structure that has been designed to resist heavy use. *Storefront* systems include, but are not limited to, exterior fenestration systems that span from the floor level or above to the ceiling of the same story on commercial buildings, with or without mullied windows and doors.

**TESTING UNIT ENCLOSURE AREA.** The area sum of all the boundary surfaces that define the *dwelling unit, sleeping unit* or occupiable *conditioned space* including top/ceiling, bottom/floor and all side walls. This does not include interior partition walls within the *dwelling unit, sleeping unit, or occupiable conditioned space*. Wall height shall be measured from the finished floor of the *conditioned space* to the finished floor or roof/ceiling air barrier above.

**THERMAL DISTRIBUTION EFFICIENCY (TDE).** The resistance to changes in air heat as air is conveyed through a distance of air duct. TDE is a heat loss calculation evaluating the difference in the heat of the air between the air duct inlet and outlet caused by differences in temperatures between the air in the duct and the duct material. TDE is expressed as a percent difference between the inlet and outlet heat in the duct.

**THERMOSTAT.** An automatic control device used to maintain temperature at a fixed or adjustable setpoint.

**TIME SWITCH CONTROL.** An automatic control device or system that controls lighting or other loads, including switching off, based on time schedules.

**U-FACTOR (THERMAL TRANSMITTANCE).** The coefficient of heat transmission (air to air) through a building component or assembly, equal to the time rate of heat flow per unit area and unit temperature difference between the warm side and cold side air films ( $\text{Btu/h} \times \text{ft}^2 \times ^\circ\text{F}$ ) [ $\text{W}/(\text{m}^2 \times \text{K})$ ].

~~**UNCONDITIONED SPACE.** A space within the building but not within the building thermal envelope.~~

**VARIABLE REFRIGERANT FLOW SYSTEM.** An engineered direct-expansion (DX) refrigerant system that incorporates a common condensing unit, at least one variable-capacity compressor, a distributed refrigerant piping network to multiple indoor fan heating and cooling units each capable of individual zone temperature control, through integral zone temperature control devices and a common communications network. Variable refrigerant flow utilizes three or more steps of control on common interconnecting piping.

~~**VAPOR RETARDER CLASS 1.** A measure of the ability of a material or assembly to limit the amount of moisture that passes through that material or assembly. Vapor retarder class 1 is defined as 0.1 perm or less when using the desiccant method with Procedure A of ASTM E96.~~

**VEGETATIVE ROOF.** An assembly of interacting components designed to waterproof a building's top surface that includes, by design, vegetation and related landscape elements.

**VENTILATION.** The natural or mechanical process of supplying conditioned or unconditioned air to, or removing such air from, any space.

**VENTILATION AIR.** That portion of supply air that comes from outside (outdoors) plus any recirculated air that has been treated to maintain the desired quality of air within a designated space.

**VISIBLE TRANSMITTANCE [VT].** The ratio of visible light entering the space through the fenestration product assembly to the incident visible light. Visible transmittance includes the effects of glazing material and frame and is expressed as a number between 0 and 1.

**VISIBLE TRANSMITTANCE, ANNUAL (VT<sub>annual</sub>).** The ratio of visible light entering the space through the fenestration product assembly to the incident visible light during the course of a year, which includes the effects of glazing material, frame, and light well or tubular conduit, and is expressed as a number between 0 and 1.

**VOLTAGE DROP.** A decrease in voltage caused by losses in the wiring systems that connect the power source to the load.

**WALK-IN COOLER.** An enclosed storage space capable of being refrigerated to temperatures above 32°F (0°C) and less than 55°F (12.8°C) that can be walked into, has a ceiling height of not less than 7 feet (2134 mm) and has a total chilled storage area of less than 3,000 square feet (279 m<sup>2</sup>).

**WALK-IN FREEZER.** An enclosed storage space capable of being refrigerated to temperatures at or below 32°F (0°C) that can be walked into, has a ceiling height of not less than 7 feet (2134 mm) and has a total chilled storage area of less than 3,000 square feet (279 m<sup>2</sup>).

**WALL, ABOVE-GRADE.** ~~A wall associated with the *building thermal envelope* that is more than 15 percent above grade and is on the exterior of the building or any wall that is associated with the *building thermal envelope* that is not on the exterior of the building.~~ A wall associated with the *building thermal envelope* that is more than 15 percent above grade and is on the exterior of the building or any wall that is associated with the *building thermal envelope* that is not on the exterior of the building. This includes, but is not limited to, between-floor spandrels, peripheral edges of floors, roof knee walls, dormer walls, gable end walls, walls enclosing a mansard roof and skylight shafts.

**WALL, BELOW-GRADE.** A wall associated with the basement or first story of the building that is part of the *building thermal envelope*, is not less than 85 percent below grade and is on the exterior of the building.

**WATER HEATER.** Any heating appliance or equipment that heats potable water and supplies such water to the potable hot water distribution system.

**ZONE.** A space or group of spaces within a building with heating or cooling requirements that are sufficiently similar so that desired conditions can be maintained throughout using a single controlling device.

# CHAPTER 3 [CE] GENERAL REQUIREMENTS

## SECTION C301 CLIMATE ZONES

**C301.1 General.** *Climate zones* from Figure C301.1 or Table C301.1 shall be used ~~in~~for determining the applicable requirements from Chapter 4. Locations not indicated in Table C301.1 shall be assigned a *climate zone* in accordance with Section C301.3.

**C301.2 Warm Humid counties.** In Table C301.1, Warm Humid counties are identified in Table C301.1 by an asterisk.

~~TABLE C301.1  
NORTH CAROLINA CLIMATE ZONES, MOISTURE REGIMES, AND WARM-HUMID  
DESIGNATIONS BY COUNTY~~

**Key:** A – Moist.  
Asterisk (\*) indicates a warm-humid location.

### US STATES

**NORTH  
CAROLINA**

4A Alamance	4A Chatham	3A Greene	5A Mitchell	3A Sampson
4A Alexander	4A Cherokee	4A Guilford	3A Montgomery	3A Scotland
5A Alleghany	3A Chowan	4A Halifax	3A Moore	3A Stanly
3A Anson	4A Clay	4A Harnett	4A Nash	4A Stokes
5A Ashe	4A Cleveland	4A Haywood	3A New Hanover*	4A Surry
5A Avery	3A Columbus*	4A Henderson	4A Northampton	4A Swain
3A Beaufort	3A Craven	4A Hertford	3A Onslow*	4A Transylvania
4A Bertie	3A Cumberland	3A Hoke	4A Orange	3A Tyrrell
3A Bladen	3A Currituck	3A Hyde	3A Pamlico	3A Union
3A Brunswick*	3A Dare	4A Iredell	3A Pasquotank	4A Vance
4A Buncombe	3A Davidson	4A Jackson	3A Pender*	4A Wake
4A Burke	4A Davie	3A Johnston	3A Perquimans	4A Warren
3A Cabarrus	3A Duplin	3A Jones	4A Person	3A Washington
4A Caldwell	4A Durham	4A Lee	3A Pitt	5A Watauga
3A Camden	3A Edgecombe	3A Lenoir	4A Polk	3A Wayne
3A Carteret*	4A Forsyth	4A Lincoln	3A Randolph	4A Wilkes
4A Caswell	4A Franklin	4A Macon	3A Richmond	3A Wilson
4A Catawba	3A Gaston	4A Madison	3A Robeson	4A Yadkin
	4A Gates	3A Martin	4A Rockingham	5A Yancey
	4A Graham	4A McDowell	3A Rowan	
	4A Granville	3A Mecklenburg	4A Rutherford	

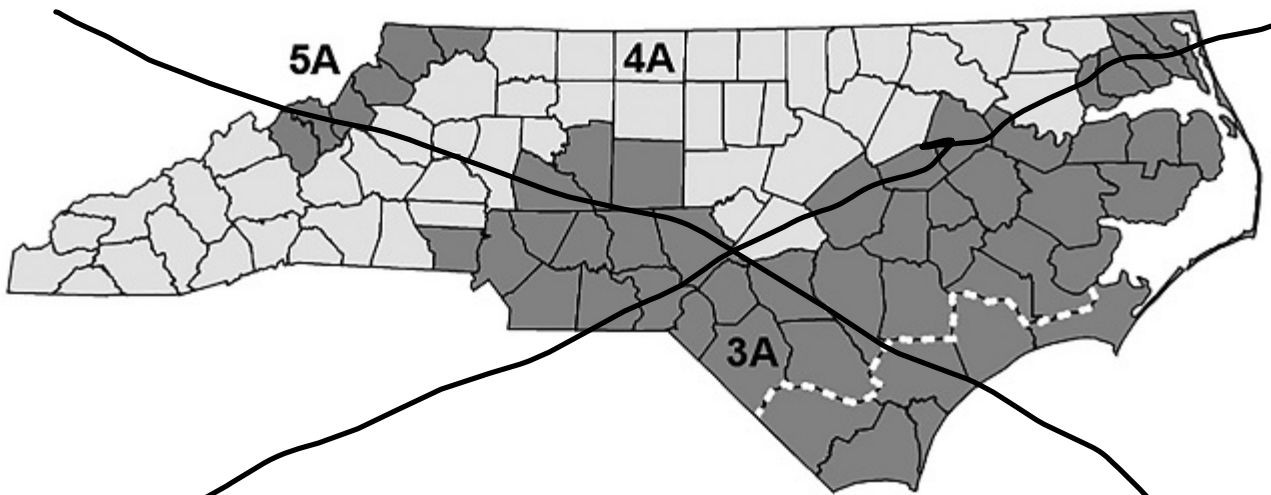

Warm and Humid Counties are below the dashed white line

**FIGURE C301.1 NORTH CAROLINA CLIMATE ZONES**

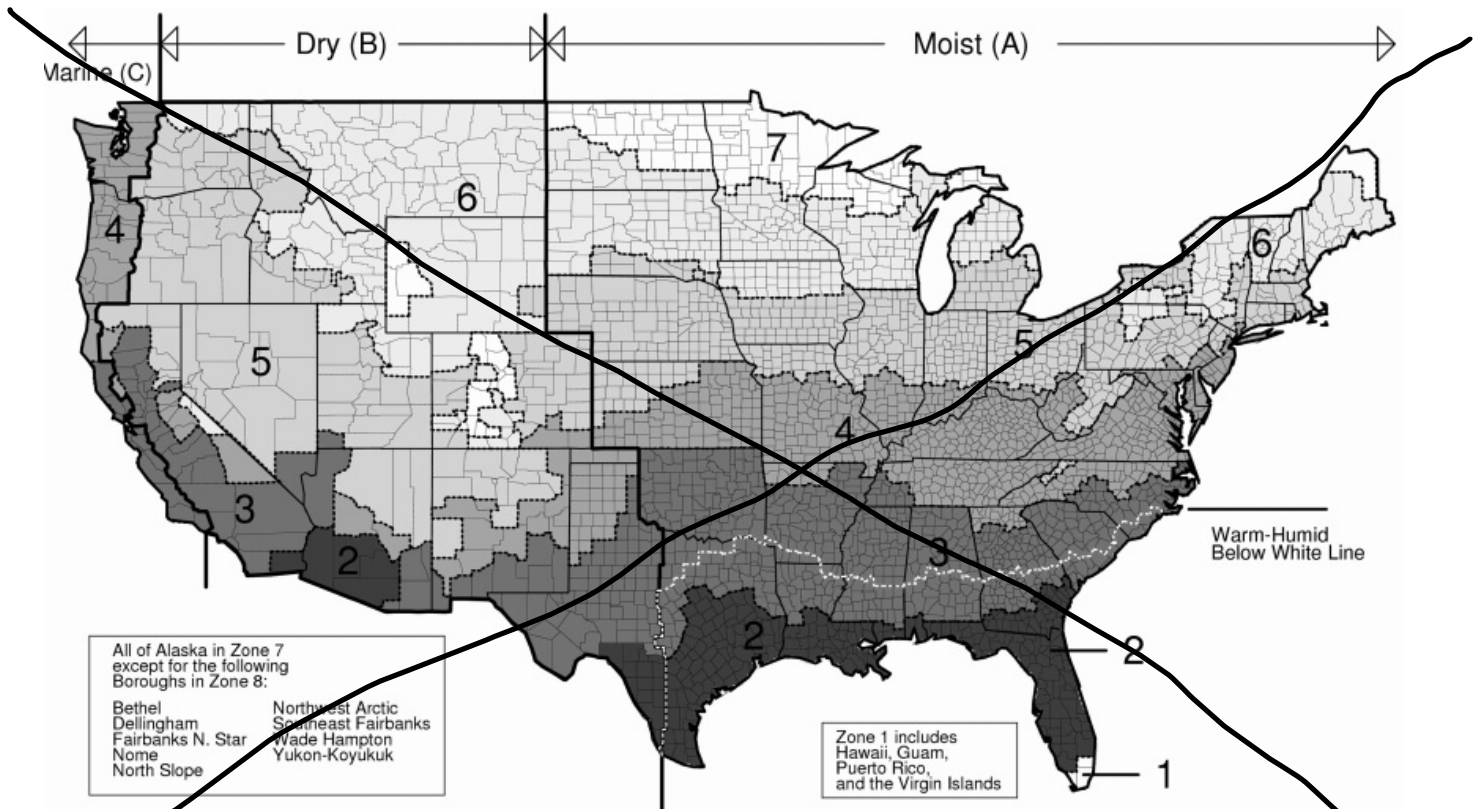

**FIGURE C301.2 CLIMATE ZONES**

**TABLE C301.1**

**NORTH CAROLINA CLIMATE ZONES, MOISTURE REGIMES, AND WARM-HUMID DESIGNATIONS BY COUNTY**

a. Key: A – Moist, B – Dry, C – Marine. Absence of moisture designation indicates moisture regime is irrelevant. Asterisk (\*) indicates a Warm Humid location.

<b><u>NORTH CAROLINA</u></b>
<u>3A Alamance</u>
<u>3A Alexander</u>
<u>5A Alleghany</u>
<u>3A Anson</u>
<u>5A Ashe</u>
<u>5A Avery</u>
<u>3A Beaufort</u>
<u>3A Bertie</u>
<u>3A Bladen</u>
<u>3A Brunswick*</u>
<u>4A Buncombe</u>
<u>4A Burke</u>
<u>3A Cabarrus</u>
<u>4A Caldwell</u>
<u>3A Camden</u>
<u>3A Carteret*</u>
<u>3A Caswell</u>
<u>3A Catawba</u>
<u>3A Chatham</u>
<u>3A Cherokee</u>
<u>3A Chowan</u>
<u>3A Clay</u>
<u>3A Cleveland</u>
<u>3A Columbus*</u>
<u>3A Craven</u>
<u>3A Cumberland</u>
<u>3A Currituck</u>
<u>3A Dare</u>
<u>3A Davidson</u>
<u>3A Davie</u>

<u>3A Duplin</u>
<u>3A Durham</u>
<u>3A Edgecombe</u>
<u>3A Forsyth</u>
<u>3A Franklin</u>
<u>3A Gaston</u>
<u>3A Gates</u>
<u>4A Graham</u>
<u>3A Granville</u>
<u>3A Greene</u>
<u>3A Guilford</u>
<u>3A Halifax</u>
<b>US STATES—continued</b>
<b>NORTH CAROLINA</b> <i>(continued)</i>
<u>3A Harnett</u>
<u>4A Haywood</u>
<u>4A Henderson</u>
<u>3A Hertford</u>
<u>3A Hoke</u>
<u>3A Hyde</u>
<u>3A Iredell</u>
<u>4A Jackson</u>
<u>3A Johnston</u>
<u>3A Jones</u>
<u>3A Lee</u>
<u>3A Lenoir</u>
<u>3A Lincoln</u>
<u>4A Macon</u>
<u>4A Madison</u>
<u>3A Martin</u>
<u>4A McDowell</u>
<u>3A Mecklenburg</u>
<u>4A Mitchell</u>
<u>3A Montgomery</u>
<u>3A Moore</u>



<u>3A Nash</u>
<u>3A New Hanover*</u>
<u>3A Northampton</u>
<u>3A Onslow*</u>
<u>3A Orange</u>
<u>3A Pamlico</u>
<u>3A Pasquotank</u>
<u>3A Pender*</u>
<u>3A Perquimans</u>
<u>3A Person</u>
<u>3A Pitt</u>
<u>3A Polk</u>
<u>3A Randolph</u>
<u>3A Richmond</u>
<u>3A Robeson</u>
<u>3A Rockingham</u>
<u>3A Rowan</u>
<u>3A Rutherford</u>
<u>3A Sampson</u>
<u>3A Scotland</u>
<u>3A Stanly</u>
<u>4A Stokes</u>
<u>4A Surry</u>
<u>4A Swain</u>
<u>4A Transylvania</u>
<u>3A Tyrrell</u>
<u>3A Union</u>
<u>3A Vance</u>
<u>3A Wake</u>
<u>3A Warren</u>
<u>3A Washington</u>
<u>5A Watauga</u>
<u>3A Wayne</u>
<u>4A Wilkes</u>

3A Wilson
4A Yadkin
5A Yancey

**C301.3 International climate zones. Climate zone definitions.** Deleted. Note: Table C301.3(1) and Table C301.3(2) contain no NC requirements but are retained for information only. To determine the climate zones for locations not listed in this code, use the following information to determine climate zone numbers and letters in accordance with Items 1 through 5.

1. Determine the thermal climate zone, 0 through 8, from Table C301.3 using the heating (HDD) and cooling degree-days (CDD) for the location.
2. Determine the moisture zone (Marine, Dry or Humid) in accordance with Items 2.1 through 2.3.
  - 2.1. If monthly average temperature and precipitation data are available, use the Marine, Dry and Humid definitions to determine the moisture zone (C, B or A).
  - 2.2. If annual average temperature information (including degree-days) and annual precipitation (i.e., annual mean) are available, use Items 2.2.1 through 2.2.3 to determine the moisture zone. If the moisture zone is not Marine, then use the Dry definition to determine whether Dry or Humid.
    - 2.2.1. If thermal climate zone is 3 and  $CDD_{50^{\circ}F} \leq 4,500$  ( $CDD_{10^{\circ}C} \leq 2500$ ), climate zone is Marine (3C).
    - 2.2.2. If thermal climate zone is 4 and  $CDD_{50^{\circ}F} \leq 2,700$  ( $CDD_{10^{\circ}C} \leq 1500$ ), climate zone is Marine (4C).
    - 2.2.3. If thermal climate zone is 5 and  $CDD_{50^{\circ}F} \leq 1,800$  ( $CDD_{10^{\circ}C} \leq 1000$ ), climate zone is Marine (5C).
  - 2.3. If only degree-day information is available, use Items 2.3.1 through 2.3.3 to determine the moisture zone. If the moisture zone is not Marine, then it is not possible to assign Humid or Dry moisture zone for this location.
    - 2.3.1. If thermal climate zone is 3 and  $CDD_{50^{\circ}F} \leq 4,500$  ( $CDD_{10^{\circ}C} \leq 2500$ ), climate zone is Marine (3C).
    - 2.3.2. If thermal climate zone is 4 and  $CDD_{50^{\circ}F} \leq 2,700$  ( $CDD_{10^{\circ}C} \leq 1500$ ), climate zone is Marine (4C).
    - 2.3.3. If thermal climate zone is 5 and  $CDD_{50^{\circ}F} \leq 1,800$  ( $CDD_{10^{\circ}C} \leq 1000$ ), climate zone is Marine (5C).
3. Marine (C) Zone definition: Locations meeting all the criteria in Items 3.1 through 3.4.
  - 3.1. Mean temperature of coldest month between 27°F (-3°C) and 65°F (18°C).
  - 3.2. Warmest month mean < 72°F (22°C).
  - 3.3. Not fewer than four months with mean temperatures over 50°F (10°C).
  - 3.4. Dry season in summer. The month with the heaviest precipitation in the cold season has at least three times as much precipitation as the month with the least precipitation in the rest of the year. The cold season is October through March in the Northern Hemisphere and April through September in the Southern Hemisphere.
4. Dry (B) definition: Locations meeting the criteria in Items 4.1 through 4.4.
  - 4.1. Not Marine (C).
  - 4.2. If 70 percent or more of the precipitation,  $P$ , occurs during the high sun period, defined as April through September in the Northern Hemisphere and October through March in the Southern Hemisphere, then the dry/humid threshold is in accordance with Equation 3-1.
 
$$P < 0.44 \times (T - 7)$$

$$[P < 20.0 \times (T + 14) \text{ in SI units}]$$

**(Equation 3-1)**

where:

$P$  = Annual precipitation, inches (mm).

$T$  = Annual mean temperature, °F (°C).
  - 4.3. If between 30 and 70 percent of the precipitation,  $P$ , occurs during the high sun period, defined as April through September in the Northern Hemisphere and October through March in the Southern Hemisphere, then the dry/humid threshold is in accordance with Equation 3-2.

$$P < 0.44 \times (T - 19.5)$$

$$[P < 20.0 \times (T + 7) \text{ in SI units}]$$

**(Equation 3-2)**

where:

$P$  = Annual precipitation, inches (mm).

$T$  = Annual mean temperature, °F (°C).

4.4. If 30 percent or less of the precipitation,  $P$ , occurs during the high sun period, defined as April through September in the Northern Hemisphere and October through March in the Southern Hemisphere, then the dry/humid threshold is in accordance with Equation 3-3.

$$P < 0.44 \times (T - 32)$$

$$[P < 20.0 \times T \text{ in SI units}]$$

**(Equation 3-3)**

where:

$P$  = Annual precipitation, inches (mm).

$T$  = Annual mean temperature, °F (°C).

5. Humid (A) definition: Locations that are not Marine (C) or Dry (B).

~~TABLE C301.3(1) INTERNATIONAL CLIMATE ZONE DEFINITIONS~~

MAJOR CLIMATE TYPE DEFINITIONS	
Marine (C) Definition—Locations meeting all four criteria:	<ol style="list-style-type: none"> <li>1. Mean temperature of coldest month between -3°C (27°F) and 18°C (65°F).</li> <li>2. Warmest month mean &lt; 22°C (72°F).</li> <li>3. At least four months with mean temperatures over 10°C (50°F).</li> <li>4. Dry season in summer. The month with the heaviest precipitation in the cold season has at least three times as much precipitation as the month with the least precipitation in the rest of the year. The cold season is October through March in the Northern Hemisphere and April through September in the Southern Hemisphere.</li> </ol>
Dry (B) Definition—Locations meeting the following criteria: Not marine and $P_{in} < 0.44 \times (TF - 19.5)$ [ $P_{cm} < 2.0 \times (TC + 7)$ in SI units]	where: $P_{in}$ = Annual precipitation in inches (cm) $T$ = Annual mean temperature in °F (°C)
Moist (A) Definition—Locations that are not marine and not dry.	
Warm-humid Definition—Moist (A) locations where either of the following wet-bulb temperature conditions shall occur during the warmest six consecutive months of the year:	<ol style="list-style-type: none"> <li>1. 67°F (19.4°C) or higher for 3,000 or more hours; or</li> <li>2. 73°F (22.8°C) or higher for 1,500 or more hours.</li> </ol>

For SI: °C = [(°F)-32]/1.8, 1 inch = 2.54 cm.

~~TABLE C301.3(2) INTERNATIONAL CLIMATE ZONE DEFINITIONS~~

ZONE NUMBER	THERMAL CRITERIA	
	IP Units	SI Units
1	9000 < CDD50°F	5000 < CDD10°C
2	6300 < CDD50°F ≤ 9000	3500 < CDD10°C ≤ 5000
3A and 3B	4500 < CDD50°F ≤ 6300 AND HDD65°F ≤ 5400	2500 < CDD10°C ≤ 3500 AND HDD18°C ≤ 3000
4 A and 4B	CDD50°F ≤ 4500 AND HDD65°F ≤ 5400	CDD10°C ≤ 2500 AND HDD18°C ≤ 3000
3C	HDD65°F ≤ 3600	HDD18°C ≤ 2000
4C	3600 < HDD65°F ≤ 5400	2000 < HDD18°C ≤ 3000
5	5400 < HDD65°F ≤ 7200	3000 < HDD18°C ≤ 4000
6	7200 < HDD65°F ≤ 9000	4000 < HDD18°C ≤ 5000
7	9000 < HDD65°F ≤ 12600	5000 < HDD18°C ≤ 7000
8	12600 < HDD65°F	7000 < HDD18°C

For SI: °C = [(°F)-32]/1.8.

**TABLE C301.3**  
**THERMAL CLIMATE ZONE DEFINITIONS**

ZONE NUMBER	THERMAL CRITERIA	
	IP Units	SI Units
0	10,800 < CDD50°F	6000 < CDD10°C
1	9,000 < CDD50°F < 10,800	5000 < CDD10°C < 6000
2	6,300 < CDD50°F < 9,000	3500 < CDD10°C < 5000
3	CDD50°F < 6,300 AND HDD65°F < 3,600	CDD10°C < 3500 AND HDD18°C < 2000
4	CDD50°F < 6,300 AND 3,600 < HDD65°F < 5,400	CDD10°C < 3500 AND 2000 < HDD18°C < 3000
5	CDD50°F < 6,300 AND 5,400 < HDD65°F < 7,200	CDD10°C < 3500 AND 3000 < HDD18°C < 4000
6	7,200 < HDD65°F < 9,000	4000 < HDD18°C < 5000
7	9,000 < HDD65°F < 12,600	5000 < HDD18°C < 7000
8	12,600 < HDD65°F	7000 < HDD18°C

For SI: °C = [(°F) – 32]/1.8.

**C301.4 Tropical climate region.** Deleted.

### SECTION C302 DESIGN CONDITIONS

**C302.1 Interior design conditions.** The interior design temperatures used for heating and cooling load calculations shall be a maximum of 72°F (22°C) for heating and minimum of 75°F (24°C) for cooling.

### SECTION C303 MATERIALS, SYSTEMS AND EQUIPMENT

**C303.1 Identification.** Materials, systems and equipment shall be identified in a manner that will allow a determination of compliance with the applicable provisions of this code.

**C303.1.1 Building thermal envelope insulation.** An *R*-value identification mark shall be applied by the manufacturer to each piece of *building thermal envelope* insulation 12 inches (305 mm) or greater in width. ~~Alternately,~~ Alternatively, the insulation installers shall provide a certification listing the type, manufacturer and *R*-value of insulation installed in each element of the *building thermal envelope*. For ~~blown~~ blown-in or sprayed insulation ~~(fiberglass and cellulose); fiberglass and cellulose insulation,~~ the initial installed thickness, settled thickness, settled *R*-value, installed density, coverage area and number of bags installed shall be indicated on the certification. For sprayed polyurethane foam (SPF) insulation, the installed thickness of the areas covered and *R*-value of installed thickness shall be indicated on the certification. For insulated siding, the *R*-value shall be labeled on the product's package and shall be indicated on the certification. The insulation installer shall sign, date and post the certification in a conspicuous location on the job site.

**Exception:** For roof insulation installed above the deck, the *R*-value shall be labeled as required by the material standards specified in Table 1508.2 of the *International Building Code*.

**C303.1.1.1 Blown-in or sprayed roof/ceiling insulation.** The thickness of blown-in or sprayed fiberglass and cellulose roof/ceiling insulation (fiberglass and cellulose) shall be written in inches (mm) on markers that are installed at least one and one or more of such markers shall be installed for every 300 square feet (28 m<sup>2</sup>) of attic area throughout the attic space. The markers shall be affixed to the trusses or joists and marked with the minimum initial installed thickness with numbers not less than 1 inch (25 mm) in height. Each marker shall face the attic access opening. Spray polyurethane foam thickness and installed R-value shall be indicated on certification provided by the insulation installer.

**C303.1.2 Insulation mark installation.** Insulating materials shall be installed such that the manufacturer's R-value mark is readily observable upon inspection. Insulating materials shall be installed such that the manufacturer's R-value mark is readily observable upon inspection. For insulation materials that are installed without an observable manufacturer's R-value mark, such as blown or draped products, an insulation certificate complying with Section C303.1.1 shall be left immediately after installation by the installer, in a conspicuous location within the building, to certify the installed R-value of the insulation material.

**C303.1.3 Fenestration product rating.** U-factors of fenestration products (windows, doors and skylights) shall be determined in accordance with NFRC 100. U factors shall be determined by an accredited, independent laboratory, and labeled and certified by the manufacturer. Products lacking such a labeled U factor shall be assigned a default U factor from Table C303.1.3(1) or C303.1.3(2). The solar heat gain coefficient (SHGC) and visible transmittance (VT) of glazed fenestration products (windows, glazed doors and skylights) shall be determined in accordance with NFRC 200 by an accredited, independent laboratory, and labeled and certified by the manufacturer. Products lacking such a labeled SHGC or VT shall be assigned a default SHGC or VT from Table C303.1.3(3).

**Exception:** When a garage door is a part of the building thermal envelope, garage door U factors shall be determined in accordance with either NFRC 100 or ANSI/DASMA 105.

U-factors of fenestration products shall be determined as follows:

1. For windows, doors and skylights, U-factor ratings shall be determined in accordance with NFRC 100.
2. Where required for garage doors and rolling doors, U-factor ratings shall be determined in accordance with either NFRC 100 or ANSI/DASMA 105.

U-factors shall be determined by an accredited, independent laboratory, and labeled and certified by the manufacturer.

Products lacking such a labeled U-factor shall be assigned a default U-factor from Table C303.1.3(1) or Table C303.1.3(2). The solar heat gain coefficient (SHGC) and visible transmittance (VT) of glazed fenestration products (windows, glazed doors and skylights) shall be determined in accordance with NFRC 200 by an accredited, independent laboratory, and labeled and certified by the manufacturer. Products lacking such a labeled SHGC or VT shall be assigned a default SHGC or VT from Table C303.1.3(3).

**TABLE C303.1.3(1)**  
**DEFAULT GLAZED FENESTRATION U-FACTORS**

FRAME TYPE	SINGLE PANE	DOUBLE PANE	SKYLIGHT	
			Single	Double
Metal	1.20	0.80	2.00	1.30
Metal with Thermal Break	1.10	0.65	1.90	1.10
Nonmetal or Metal Clad	0.95	0.55	1.75	1.05
Glazed Block	0.60			

**TABLE C303.1.3(1)**  
**DEFAULT GLAZED WINDOW, GLASS DOOR AND SKYLIGHT U-FACTORS**

FRAME TYPE	WINDOW AND GLASS DOOR		SKYLIGHT	
	Single	Double	Single	Double
Metal	1.20	0.80	2.00	1.30

<u>Metal with Thermal Break</u>	<u>1.10</u>	<u>0.65</u>	<u>1.90</u>	<u>1.10</u>
<u>Nonmetal or Metal Clad</u>	<u>0.95</u>	<u>0.55</u>	<u>1.75</u>	<u>1.05</u>
<u>Glazed Block</u>	<u>0.60</u>			

**TABLE C303.1.3(2)  
DEFAULT DOOR  
U-FACTORS**

DOOR TYPE	U-FACTOR
Uninsulated Metal	1.20
Insulated Metal	0.60
Wood	0.50
Insulated, nonmetal edge, max 45% glazing, any glazing double pane	0.35

**TABLE C303.1.3(2)  
DEFAULT OPAQUE DOOR U-FACTORS**

DOOR TYPE	OPAQUE U-FACTOR
<u>Uninsulated Metal</u>	<u>1.20</u>
<u>Insulated Metal (Rolling)</u>	<u>0.90</u>
<u>Insulated Metal (Other)</u>	<u>0.60</u>
<u>Wood</u>	<u>0.50</u>
<u>Insulated, nonmetal edge, max 45% glazing, any glazing double pane</u>	<u>0.35</u>

**TABLE C303.1.3(3)  
DEFAULT GLAZED FENESTRATION SHGC AND VT**

	SINGLE GLAZED		DOUBLE GLAZED		GLAZED BLOCK
	Clear	Tinted	Clear	Tinted	
SHGC	0.8	0.7	0.7	0.6	0.6
VT	0.6	0.3	0.6	0.3	0.6

**C303.1.4 Insulation product rating.** The thermal resistance ( $R$ -value) of insulation shall be determined in accordance with the US Federal Trade Commission  $R$ -value rule (CFR Title 16, Part 460) in units of  $h \times ft^2 \times ^\circ F/Btu$  at a mean temperature of  $75^\circ F$  ( $24^\circ C$ ).

**C303.1.4.1 Insulated siding.** The thermal resistance ( $R$ -value) of insulated siding shall be determined in accordance with ASTM C1363. Installation for testing shall be in accordance with the manufacturer's instructions.

**C303.2 Installation.** Materials, systems and equipment shall be installed in accordance with the manufacturer's instructions and the *International Building Code*.

**C303.2.1 Protection of exposed foundation insulation.** Insulation applied to the exterior of basement walls, crawl space walls and the perimeter of slab-on-grade floors shall have ~~an~~ a rigid, opaque and weather-resistant protective covering to prevent the degradation of the insulation's thermal performance. The protective covering shall cover the exposed exterior insulation and extend not less than 6 inches (153 mm) below grade.

**C303.2.2 Multiple layers of continuous insulation board.** Where two or more layers of continuous insulation board are used in a construction assembly, the continuous insulation boards shall be installed in accordance with Section C303.2. Where the continuous insulation board manufacturer's instructions do not address installation of two or more layers, the edge joints between each layer of continuous insulation boards shall be staggered.

**C303.3 Maintenance information.** Maintenance instructions shall be furnished for equipment and systems that require preventive maintenance.

# CHAPTER 4 [CE] COMMERCIAL ENERGY EFFICIENCY

## SECTION C401 GENERAL

**C401.1 Scope.** The provisions in this chapter are applicable to commercial *buildings* and their *building sites*.

**C401.2 Application.** ~~Commercial buildings shall comply with one of the following:~~

- ~~1. The requirements of ANSI/ASHRAE/IESNA 90.1.~~
- ~~2. The requirements of Sections C402 through C405. In addition, commercial buildings shall comply with Section C406 and tenant spaces shall comply with Section C406.1.1.~~
- ~~3. The requirements of Sections C402.5, C403.2, C404, C405.2, C405.3, C405.5, C405.6 and C407. The building energy cost shall be equal to or less than 85 percent of the standard reference design building.~~
- ~~4. COMcheck keyed to the 2018 IECC or ASHRAE 90.1-2016 shall be permitted to demonstrate compliance with this code.~~

Commercial buildings shall comply with Section C401.2.1 or C401.2.2. \*

**C401.2.1 International Energy Conservation Code.** Commercial buildings shall comply with one of the following:

1. Prescriptive Compliance. The Prescriptive Compliance option requires compliance with Sections C402 through C406 and Section C408. Dwelling units and sleeping units in Group R-2 buildings without systems serving multiple units shall be deemed to be in compliance with this chapter, provided that they comply with Section R406.
2. Total Building Performance. The Total Building Performance option requires compliance with Section C407.

**Exception:** Additions, alterations, repairs and changes of occupancy to existing buildings complying with Chapter 5.

**C401.2.2 ASHRAE 90.1.** Commercial buildings shall comply with the requirements of ANSI/ASHRAE/IESNA 90.1- and approved addenda. The use of Comcheck Web for code version 90.1-2019 standard and the appropriate location shall be permitted to demonstrate compliance.

**C401.3 Thermal envelope certificate.** A permanent thermal envelope certificate shall be completed by an *approved* party. Such certificate shall be posted on a wall in the space where the space conditioning equipment is located, a utility room or other *approved* location. If located on an electrical panel, the certificate shall not cover or obstruct the visibility of the circuit directory label, service disconnect label or other required labels. A copy of the certificate shall also be included in the construction files for the project. The certificate shall include the following:

1. *R*-values of insulation installed in or on ceilings, roofs, walls, foundations and slabs, *basement walls*, crawl space walls and floors and ducts outside *conditioned spaces*.
2. *U*-factors and *solar heat gain coefficients* (SHGC) of fenestrations.
3. Results from any *building envelope air leakage* testing performed on the *building*.

Where there is more than one value for any component of the building envelope, the certificate shall indicate the area-weighted average value where available. If the area-weighted average is not available, the certificate shall list each value that applies to 10 percent or more of the total component area.

## SECTION C402 BUILDING ENVELOPE REQUIREMENTS

**C402.1 General (Prescriptive).** *Building thermal envelope* assemblies for buildings that are intended to comply with the code on a prescriptive basis in accordance with the compliance path described in Item ~~21~~ of Section ~~C401.2~~C401.2.1 shall comply with the following:



1. The opaque portions of the *building thermal envelope* shall comply with the specific insulation requirements of Section C402.2 and the thermal requirements of either the *R*-value-based method of Section C402.1.3; the *U*-, *C*- and *F*-factor-based method of Section C402.1.4; or the component performance alternative of Section C402.1.5.
2. Roof solar reflectance and thermal emittance shall comply with Section C402.3.
3. Fenestration in building envelope assemblies shall comply with Section C402.4.
4. Air leakage of building envelope assemblies shall comply with Section C402.5.

Alternatively, where buildings have a vertical fenestration area or skylight area exceeding that allowed in Section C402.4, the building and *building thermal envelope* shall comply with ~~Section C401.2, Item 1 or Section C401.2, Item 3.~~ Item 2 of Section C401.2.1 or Section C401.2.2.

Walk-in coolers, walk-in freezers, refrigerated warehouse coolers and refrigerated warehouse freezers shall comply with Section C403.11.

**C402.1.1 Low energy buildings.** ~~Low energy buildings, greenhouses, and equipment buildings.~~ The following ~~low energy~~ buildings, or portions thereof separated from the remainder of the building by *building thermal envelope* assemblies complying with this section, shall be exempt from the *building thermal envelope* provisions of Section C402.

1. Those with a peak design rate of energy usage less than 3.4 Btu/h x ft<sup>2</sup> (10.7 W/m<sup>2</sup>) or 1.0 watt per square foot (10.7 W/m<sup>2</sup>) of floor area for space conditioning purposes.
2. Those that do not contain *conditioned space*.
3. ~~Greenhouses.~~

**C402.1.1.1 Greenhouses.** Greenhouse structures or areas that are mechanically heated or cooled and that comply with all of the following shall be exempt from the building envelope requirements of this code:

1. Exterior opaque envelope assemblies comply with Sections C402.2 and C402.4.5.

**Exception:** Low energy greenhouses that comply with Section C402.1.1.

2. Interior partition *building thermal envelope* assemblies that separate the greenhouse from *conditioned space* comply with Sections C402.2, C402.4.3 and C402.4.5.
3. Fenestration assemblies that comply with the thermal envelope requirements in Table C402.1.1.1. The *U*-factor for a roof shall be for the roof assembly or a roof that includes the assembly and an internal curtain system.

**Exception:** Unconditioned greenhouses.

**TABLE C402.1.1.1  
FENESTRATION THERMAL ENVELOPE  
MAXIMUM REQUIREMENTS**

COMPONENT	<i>U</i> -FACTOR (BTU/h × ft <sup>2</sup> × °F)
Skylight	<u>0.5</u>
Vertical fenestration	<u>0.7</u>

**C402.1.2 Equipment buildings.** Deleted.

**C402.1.1.2 Equipment buildings.** Buildings that comply with the following shall be exempt from the *building thermal envelope* provisions of this code:

1. Are separate buildings with floor area not more than 1,200 square feet (110 m<sup>2</sup>).
2. Are intended to house electric equipment with installed equipment power totaling not less than 7 watts per square foot (75 W/m<sup>2</sup>) and not intended for human occupancy.
3. Have a heating system capacity not greater than (17,000 Btu/hr) (5 kW) and a heating thermostat setpoint that is F restricted to not more than 50°F (10°C).
4. Have an average wall and roof *U*-factor less than 0.200 in *Climate Zones* 3 through 5.
5. Comply with the roof solar reflectance and thermal emittance provisions for *Climate Zone* 3.

**C402.1.2 Rooms containing fuel-burning appliances.** In *Climate Zones 3 through 5*, where combustion air is supplied through openings in an exterior wall to a room or space containing a space-conditioning fuel-burning appliance, one of the following shall apply:

1. The room or space containing the appliance shall be located outside of the *building thermal envelope*.
2. The room or space containing the appliance shall be enclosed and isolated from conditioned spaces inside the *building thermal envelope*. Such rooms shall comply with all of the following:
  - 2.1 The walls, floors and ceilings that separate the enclosed room or space from conditioned spaces shall be insulated to be not less than equivalent to the insulation requirement of below-grade walls as specified in Table C402.1.3 or Table C402.1.4.
  - 2.2 The walls, floors and ceilings that separate the enclosed room or space from conditioned spaces shall be sealed in accordance with Section C402.5.1.2.
  - 2.3 The doors into the enclosed room or space shall be fully gasketed.
  - 2.4 Piping serving as part of a heating or cooling system and ducts in the enclosed room or space shall be insulated in accordance with Section C403. Service water piping shall be insulated in accordance with Section C404.
  - 2.5 Where an air duct supplying combustion air to the enclosed room or space passes through *conditioned space*, the duct shall be insulated to an R-value of not less than R-8.

**Exception:** Fireplaces and stoves complying with Sections 901 through 905 of the *International Mechanical Code*, and Section 2111.14 of the *International Building Code*.

**C402.1.3 Insulation component R-value-based method.** *Building thermal envelope* opaque assemblies shall comply with the requirements of Sections C402.2 and C402.4 based on the *climate zone* specified in Chapter 3. For opaque portions of the *building thermal envelope* intended to comply on an insulation component *R-value* basis, ~~the R-values for insulation in framing cavities, where required, and for continuous insulation, where required, shall be not less than that specified in Table C402.1.3, based on the climate zone specified in Chapter 3; the R-values for cavity insulation and continuous insulation shall be not less than that specified in Table C402.1.3.~~ Where cavity insulation is installed in multiple layers, the cavity insulation *R-values* shall be summed to determine compliance with the cavity insulation *R-value* requirements. Where continuous insulation is installed in multiple layers, the continuous insulation *R-values* shall be summed to determine compliance with the continuous insulation *R-value* requirements. Cavity insulation *R-values* shall not be used to determine compliance with the continuous insulation *R-value* requirements in Table C402.1.3. Commercial buildings or portions of commercial buildings enclosing *Group R* occupancies shall use the *R-values* from the “*Group R*” column of Table C402.1.3. Commercial buildings or portions of commercial buildings enclosing occupancies other than *Group R* shall use the *R-values* from the “All other” column of Table C402.1.3. ~~The thermal resistance or R value of the insulating material installed continuously within or on the below-grade exterior walls of the building envelope required in accordance with Table C402.1.3 shall extend to a depth of not less than 10 feet (3048 mm) below the outside finished ground level, or to the level of the lowest floor of the conditioned space enclosed by the below grade wall, whichever is less. Opaque swinging doors and opaque nonswinging doors shall comply with Table C402.1.3.~~

**TABLE C402.1.3  
OPAQUE THERMAL ENVELOPE INSULATION COMPONENT MINIMUM REQUIREMENTS, R-VALUE METHOD<sup>d</sup>**

CLIMATE ZONE	3		4		5	
	All other	Group R	All other	Group R	All other	Group R
<b>Roofs</b>						
Insulation entirely above roof deck	R-25ci	R-25ci	R-30ci	R-30ci	R-30ci	R-30ci
Metal buildings <sup>a, b</sup>	R-10 + R-19 FC	R-10 + R-19 FC	R-19 + R-11 LS; R-25 + R-8 LS	R-19 + R-11 LS; R-25 + R-8 LS	R-19 + R-11 LS; R-25 + R-8 LS	R-19 + R-11 LS; R-25 + R-8 LS
Attic and other – wood framing <sup>c</sup>	R-38	R-38	R-42	R-42	R-42	R-42
Attic and other – steel framing <sup>c</sup>	R-38	R-38	R-49	R-49	R-49	R-49
<b>Walls, above grade</b>						
Mass	R-7.5ci	R-9.5ci	R-9.5ci	R-11.4ci	R-11.4ci	R-15ci
Metal building <sup>b</sup>	R-0 + R-9.8ci	R-0 + R-13ci	R-0 + R-15.8ci	R-0 + R-19ci	R-0 + R-19ci	R-0 + R-19ci
Metal framed	R-13 + R-7.5ci	R-13 + R-7.5ci	R-13 + R-7.5ci	R-13 + R-7.5ci	R-13 + R-7.5ci	R-13 + R-10ci
Wood framed and other	R-13 + R-3.8ci or R-20	R-13 + R-3.8ci or R-20	R-13 + R-3.8ci or R-20	R-13 + R-3.8ci or R-20	R-13 + R-3.8ci or R-20	R-13 + R-7.5ci or R-20 + R-3.8ci
<b>Walls, below grade</b>						
Below-grade wall <sup>e</sup>	R-7.5ci	R-7.5ci	R-7.5ci	R-10ci	R-7.5ci	R-10ci
<b>Floors</b>						
Mass	R-12.5ci	R-12.5ci	R-14.6ci	R-16.7ci	R-14.6ci	R-16.7ci
Joist/Framing	R-30 <sup>d</sup>	R-30 <sup>d</sup>	R-38	R-38	R-38	R-38
<b>Slab-on-grade floors<sup>a</sup></b>						
Unheated slabs	NR	R-10 for 24"	R-15 for 24"	R-15 for 24"	R-15 for 24"	R-20 for 24"
Heated slabs	R-15 for 24"	R-15 for 24"	R-20 for 24"	R-20 for 48"	R-20 for 48"	R-20 for 48"
<b>Opaque doors</b>						
Swinging	U-0.70	U-0.50	U-0.50	U-0.50	U-0.50	U-0.50
Nonswinging	U-0.50	U-0.50	U-0.50	U-0.50	U-0.50	U-0.50

For SI: 1 inch = 25.4 mm.

ci = Continuous insulation, FC = Filled Cavity, LS = Liner system, NR = No requirement.

LS = Liner system—Liner systems shall have a minimum R-3 thermal spacer block between the purlins and the metal roof panels as required, unless compliance is shown by overall assembly U-factor.

FC = Filled cavity—Filled cavity assemblies shall have a minimum R-5 thermal spacer block between the purlins and the metal roof panels as required, unless compliance is shown by the overall assembly U-factor.

a. When using R-value compliance method, a thermal spacer block is required, otherwise use the U-factor compliance method. [See Table C402.1.3(1)].

b. Assembly descriptions can be found in Table C402.1.3(1).

c. For monolithic slabs, insulation shall be applied downward to the bottom of the footing. For floating slabs, insulation shall extend to the bottom of the foundation wall or 24 inches, whichever is less.

d. Steel floor joist systems shall to be R-38.

e. R-30 shall be deemed to satisfy the requirement for R-38 wherever the full height of uncompressed R-30 insulation extends over the wall top plate at the eaves. Similarly, R-38 shall be deemed to satisfy the requirement for R-42 or R-49 wherever the full height of uncompressed R-38 insulation extends over the wall top plate at the eaves.

f. Assembly descriptions can be found in ANSI/ASHRAE/IESNA Appendix A.

**TABLE C402.1.3**

**OPAQUE THERMAL ENVELOPE INSULATION COMPONENT MINIMUM REQUIREMENTS, R-VALUE METHOD<sup>a</sup>**

CLIMATE ZONE	3		4		5	
	All other	Group R	All other	Group R	All other	Group R
<b>Roofs</b>						
Insulation entirely above roof deck	R-25ci	R-25ci	R-30ci	R-30ci	R-30ci	R-30ci
Metal buildings <sup>b</sup>	R-19 + R-11 LS	R-19 + R-11 LS	R-19 + R-11 LS	R-19 + R-11 LS	R-19 + R-11 LS	R-19 + R-11 LS
Attic and other	R-38	R-38	R-49	R-49	R-49	R-49
<b>Walls, above grade</b>						
Mass <sup>c</sup>	R-7.6ci	R-9.5ci	R-9.5ci	R-11.4ci	R-11.4ci	R-15ci

<u>Metal building</u>					<u>R-13 + R-6.5ci</u>	<u>R-13 + R-13ci</u>	<u>R-13 + R-13ci</u>	<u>R-13 + R-14ci</u>	<u>R-13 + R-14ci</u>	<u>R-13 + R-14ci</u>						
<u>Metal framed</u>					<u>R-13 + R-7.5ci</u>	<u>R-13 + R-7.5ci</u>	<u>R-13 + R-7.5ci</u>	<u>R-13 + R-7.5ci</u>	<u>R-13 + R-10ci</u>	<u>R-13 + R-10ci</u>						
<u>Wood framed and other</u>					<u>R-13 + R-3.8ci or R-20</u>	<u>R-13 + R-3.8ci or R-20</u>	<u>R-13 + R-3.8ci or R-20</u>	<u>R-13 + R-3.8ci or R-20</u>	<u>R-13 + R-7.5ci or R20 + R3.8ci</u>	<u>R-13 + R-7.5ci or R-20 + R- 3.8ci</u>						
<u>Walls, below grade</u>																
<u>Below-grade wall<sup>d</sup></u>					<u>R-7.5ci</u>	<u>R-7.5ci</u>	<u>R-7.5ci</u>	<u>R-10ci</u>	<u>R-7.5ci</u>	<u>R-10ci</u>						
<u>Floors</u>																
<u>Mass<sup>e</sup></u>					<u>R-12.5ci</u>	<u>R-12.5ci</u>	<u>R-14.6ci</u>	<u>R-16.7ci</u>	<u>R-14.6ci</u>	<u>R-16.7ci</u>						
<u>Joist/framing</u>					<u>R-30<sup>e</sup></u>	<u>R-30<sup>e</sup></u>	<u>R-38</u>	<u>R-38</u>	<u>R-38</u>	<u>R-38</u>						
<u>Slab-on-grade floors</u>																
<u>Unheated slabs</u>					<u>NR</u>	<u>R-10 for 24" below</u>	<u>R-15 for 24" below</u>	<u>R-15 for 24" below</u>	<u>R-15 for 24" below</u>	<u>R-20 for 24" below</u>						
<u>Heated slabs<sup>g</sup></u>					<u>R-10 for 24" below+ R-5 full slab</u>	<u>R-10 for 24" below+ R-5 full slab</u>	<u>R-15 for 24" below+ R-5 full slab</u>	<u>R-15 for 24" below+ R-5 full slab</u>	<u>R-15 for 36" below+ R-5 full slab</u>	<u>R-15 for 36" below+ R-5 full slab</u>						

For SI: 1 inch = 25.4 mm, 1 pound per square foot = 4.88 kg/m<sup>2</sup>, 1 pound per cubic foot = 16 kg/m<sup>3</sup>.

ci = Continuous Insulation, NR = No Requirement, LS = Liner System.

a. Assembly descriptions can be found in ANSI/ASHRAE/IESNA 90.1 Appendix A.

b. Where using *R*-value compliance method, a thermal spacer block shall be provided, otherwise use the *U*-factor compliance method in Table C402.1.4.

c. Steel floor joist systems shall be insulated to R-38.

d. Where heated slabs are below grade, below-grade walls shall comply with the exterior insulation requirements for heated slabs.

e. "Mass floors" shall be in accordance with Section C402.2.3.

f. "Mass walls" shall be in accordance with Section C402.2.2.

g. The first value is for perimeter insulation and the second value is for full, under-slab insulation. Perimeter insulation is not required to extend below the bottom of the slab.

~~TABLE C402.1.3(1) BUILDING ENVELOPE REQUIREMENTS — OPAQUE ASSEMBLIES~~

<u>ROOFS</u>	<u>DESCRIPTION</u>
<u>R-10 + R-19 FC</u>	<u>Filled cavity fiberglass insulation.</u> The first rated <i>R</i> -value of insulation represents faced or unfaced insulation installed between the purlins. The second rated <i>R</i> -value of insulation represents unfaced insulation installed above the first layer, perpendicular to the purlins and compressed when the metal roof panels are attached. A supporting structure retains the bottom of the first layer at the prescribed depth required for the full thickness of the insulation. A minimum R-5 thermal spacer block between the purlins and the metal roof panels is required, unless compliance is shown by the overall assembly <i>U</i> -factor.
<u>R-19 + R11 LS R-25 + R-8 LS</u>	<u>Liner System with minimum R-3 thermal spacer block.</u> A continuous membrane is installed below the purlins and uninterrupted by framing members. Uncompressed, unfaced insulation rests on top of the membrane between the purlins. For multilayer installations, the last rated <i>R</i> -value of insulation is for unfaced insulation draped over purlins and then compressed when the metal roof panels are attached. A minimum R-3 thermal spacer block between the purlins and the metal roof panels is required unless compliance is shown by overall <i>U</i> -factor.
<u>Walls</u>	
<u>R-0 + R-9.8ci R-0 + R-13ci R-0 + R-15.6ci R-0 + R-19ci</u>	<u>The first rated <i>R</i>-value of insulation is for insulation compressed between metal wall panels and the steel structure. For assemblies with continuous insulation, the continuous insulation is installed on the inside or the outside of the girts, uncompressed and uninterrupted by framing members.</u>

**C402.1.4 Assembly *U*-factor, *C*-factor or *F*-factor-based method.** Building thermal envelope opaque assemblies shall meet the requirements of Sections C402.2 and C402.4 based on the climate zone specified in Chapter 3. Building thermal envelope

opaque assemblies intended to comply on an assembly *U*-, *C*- or *F*-factor basis shall have a *U*-, *C*- or *F*-factor not greater than that specified in Table C402.1.4. Commercial buildings or portions of commercial buildings enclosing *Group R* occupancies shall use the *U*-, *C*- or *F*-factor from the “*Group R*” column of Table C402.1.4. Commercial buildings or portions of commercial buildings enclosing occupancies other than *Group R* shall use the *U*-, *C*- or *F*-factor from the “All other” column of Table C402.1.4. The *C*-factor for the below-grade exterior walls of the building envelope, as required in accordance with Table C402.1.4, shall extend to a depth of 10 feet (3048 mm) below the outside finished ground level, or to the level of the lowest floor, whichever is less. Opaque swinging doors and opaque nonswinging doors shall comply with Table C402.1.3.

**TABLE C402.1.4  
OPAQUE THERMAL ENVELOPE ASSEMBLY MAXIMUM REQUIREMENTS, U-FACTOR METHOD<sup>a, b</sup>**

CLIMATE ZONE	3		4		5	
	All other	Group R	All other	Group R	All other	Group R
<b>Roofs</b>						
Insulation entirely above deck	U-0.039	U-0.039	U-0.032	U-0.032	U-0.032	U-0.032
Metal buildings	U-0.041	U-0.041	U-0.037	U-0.037	U-0.037	U-0.037
Attic and other – wood framing	U-0.027	U-0.027	U-0.024	U-0.024	U-0.024	U-0.024
Attic and other – steel framing	U-0.035	U-0.035	U-0.029	U-0.029	U-0.029	U-0.029
<b>Walls, above grade</b>						
Mass	U-0.123	U-0.104	U-0.104	U-0.090	U-0.090	U-0.071
Metal building	U-0.094	U-0.075	U-0.060	U-0.050	U-0.050	U-0.050
Metal framed	U-0.064	U-0.064	U-0.064	U-0.064	U-0.064	U-0.055
Wood framed and other	U-0.064	U-0.064	U-0.064	U-0.064	U-0.064	U-0.051
<b>Walls, below grade</b>						
Below-grade wall <sup>c</sup>	C-0.119	C-0.119	C-0.119	C-0.092	C-0.119	C-0.092
<b>Floors</b>						
Mass	U-0.064	U-0.064	U-0.057	U-0.051	U-0.057	U-0.051
Joist/framing – wood	U-0.033	U-0.033	U-0.026	U-0.026	U-0.026	U-0.026
Joist/framing – steel	U-0.032	U-0.032	U-0.032	U-0.032	U-0.032	U-0.032
<b>Slab-on-grade floors</b>						
Unheated slabs	F-0.750 <sup>d</sup>	F-0.540	F-0.520	F-0.520	F-0.520	F-0.510
Heated slabs <sup>e</sup>	F-0.860	F-0.860	F-0.843	F-0.688	F-0.688	F-0.688

- a. Use of opaque assembly *U*-factors, *C*-factors, and *F*-factors from ANSI/ASHRAE/IESNA 90.1 Appendix A shall be permitted, provided the construction, excluding the cladding system on walls, complies with the appropriate construction details from ANSI/ASHRAE/IESNA 90.1 Appendix A.
- b. Opaque assembly *U*-factors based on designs tested in accordance with ASTM C1363 shall be permitted. The *R*-value of continuous insulation shall be permitted to be added to or subtracted from the original tested design.
- c. Where heated slabs are below grade, below-grade walls shall comply with the *F*-factor requirements for heated slabs.
- d. These *C*-, *F*- and *U*-factors are based on assemblies that are not required to contain insulation.
- e. Evidence of compliance with the *F*-factors indicated in the table for heated slabs shall be demonstrated by the application of the unheated slab *F*-factors and *R*-values derived from ASHRAE 90.1 Appendix A.

**TABLE C402.1.4  
OPAQUE THERMAL ENVELOPE ASSEMBLY MAXIMUM REQUIREMENTS, U-FACTOR METHOD<sup>a, b</sup>**

CLIMATE ZONE	3		4		5		6		7		8	
	All other	Group R	All other	Group R	All other	Group R						
<b>Roofs</b>												
Insulation entirely above roof deck	U-0.039	U-0.039	U-0.032	U-0.032	U-0.032	U-0.032						
Metal buildings	U-0.035	U-0.035	U-0.035	U-0.035	U-0.035	U-0.035						
Attic and other	U-0.027	U-0.027	U-0.021	U-0.021	U-0.021	U-0.021						
<b>Walls, above grade</b>												
Mass <sup>c</sup>	U-0.123	U-0.104	U-0.104	U-0.090	U-0.090	U-0.071						
Metal building	U-0.079	U-0.052	U-0.052	U-0.050	U-0.050	U-0.050						
Metal framed	U-0.064	U-0.064	U-0.064	U-0.064	U-0.055	U-0.055						

Wood framed and other <sup>c</sup>					<u>U-0.064</u>	<u>U-0.064</u>	<u>U-0.064</u>	<u>U-0.064</u>	<u>U-0.051</u>	<u>U-0.051</u>						
<b>Walls, below grade</b>																
Below-grade wall <sup>e</sup>					<u>C-0.119</u>	<u>C-0.119</u>	<u>C-0.119</u>	<u>C-0.092</u>	<u>C-0.119</u>	<u>C-0.092</u>						
<b>Floors</b>																
Mass <sup>d</sup>					<u>U-0.064</u>	<u>U-0.064</u>	<u>U-0.057</u>	<u>U-0.051</u>	<u>U-0.057</u>	<u>U-0.051</u>						
Joist/framing					<u>U-0.032</u>	<u>U-0.032</u>	<u>U-0.026</u>	<u>U-0.026</u>	<u>U-0.026</u>	<u>U-0.026</u>						
<b>Slab-on-grade floors</b>																
Unheated slabs					<u>F-0.73<sup>e</sup></u>	<u>F-0.54</u>	<u>F-0.52</u>	<u>F-0.52</u>	<u>F-0.52</u>	<u>F-0.51</u>						
Heated slabs <sup>f</sup>					<u>F-0.66</u>	<u>F-0.66</u>	<u>F-0.62</u>	<u>F-0.62</u>	<u>F-0.62</u>	<u>F-0.62</u>						
<b>Opaque doors</b>																
<b><u>Nonswinging door</u></b>					<u>U-0.31</u>	<u>U-0.31</u>	<u>U-0.31</u>	<u>U-0.31</u>	<u>U-0.31</u>	<u>U-0.31</u>						
<b><u>Swinging door<sup>h</sup></u></b>					<u>U-0.37</u>	<u>U-0.37</u>	<u>U-0.37</u>	<u>U-0.37</u>	<u>U-0.37</u>	<u>U-0.37</u>						
<b><u>Garage door &lt; 14% glazing<sup>i</sup></u></b>					<u>U-0.31</u>	<u>U-0.31</u>	<u>U-0.31</u>	<u>U-0.31</u>	<u>U-0.31</u>	<u>U-0.31</u>						

For SI: 1 pound per square foot = 4.88 kg/m<sup>2</sup>, 1 pound per cubic foot = 16 kg/m<sup>3</sup>.

ci = Continuous Insulation, NR = No Requirement, LS = Liner System.

- a. Where assembly *U*-factors, *C*-factors and *F*-factors are established in ANSI/ASHRAE/IESNA 90.1 Appendix A, such opaque assemblies shall be a compliance alternative where those values meet the criteria of this table, and provided that the construction, excluding the cladding system on walls, complies with the appropriate construction details from ANSI/ASHRAE/IESNA 90.1 Appendix A.
- b. Where *U*-factors have been established by testing in accordance with ASTM C1363, such opaque assemblies shall be a compliance alternative where those values meet the criteria of this table. The *R*-value of continuous insulation shall be permitted to be added to or subtracted from the original tested design.
- c. Where heated slabs are below grade, below-grade walls shall comply with the *U*-factor requirements for above-grade mass walls.
- d. "Mass floors" shall be in accordance with Section C402.2.3.
- e. Not used.
- f. The first value is for perimeter insulation and the second value is for full, under-slab insulation.
- g. "Mass walls" shall be in accordance with Section C402.2.2.
- h. Swinging door *U*-factors shall be determined in accordance with NFRC-100.
- i. Garage doors having a single row of fenestration shall have an assembly *U*-factor less than or equal to 0.44 in Climate Zones 0 through 6 and less than or equal to 0.36 in Climate Zones 7 and 8, provided that the fenestration area is not less than 14 percent and not more than 25 percent of the total door area.

**C402.1.4.1 Roof/ceiling assembly.** The maximum roof/ceiling assembly *U*-factor shall not exceed that specified in Table C402.1.4 based on construction materials used in the roof/ceiling assembly.

**C402.1.4.1.1 Tapered, above-deck insulation based on thickness.** Where used as a component of a maximum roof/ceiling assembly *U*-factor calculation, the sloped roof insulation *R*-value contribution to that calculation shall use the average thickness in inches (mm) along with the material *R*-value-per-inch (per-mm) solely for *U*-factor compliance as prescribed in Section C402.1.4.

**C402.1.4.1.2 Suspended ceilings.** Insulation installed on suspended ceilings having removable ceiling tiles shall not be considered part of the assembly *U*-factor of the roof/ceiling construction.

**C402.1.4.1.3 Joints staggered.** Continuous insulation board shall be installed in not less than two layers, and the edge joints between each layer of insulation shall be staggered, except where insulation tapers to the roof deck at a gutter edge, roof drain or scupper.

**C402.1.4.1C402.1.4.2 Thermal resistance of cold-formed steel walls.** *U*-factors of walls with cold-formed steel studs shall be permitted to be determined in accordance with Equation 4-1.

$$U = 1/[R_s + (ER)] \quad \text{(Equation 4-1)}$$

where:

$R_s$  = The cumulative  $R$ -value of the wall components along the path of heat transfer, excluding the *cavity insulation* and steel studs.

$ER$  = The effective  $R$ -value of the *cavity insulation* with steel studs, studs as specified in Table C402.1.4.2.

**TABLE C402.1.4.1C402.1.4.2**  
**EFFECTIVE R-VALUES FOR STEEL STUD WALL ASSEMBLIES**

NOMINAL STUD DEPTH (inches)	SPACING OF FRAMING (inches)	CAVITY R-VALUE (insulation)	CORRECTION FACTOR ( $F_c$ )	EFFECTIVE R-VALUE (ER) (Cavity R-Value $\times F_c$ )
3 <sup>1/2</sup>	16	13	0.46	5.98
		15	0.43	6.45
3 <sup>1/2</sup>	24	13	0.55	7.15
		15	0.52	7.80
6	16	19	0.37	7.03
		21	0.35	7.35
6	24	19	0.45	8.55
		21	0.43	9.03
8	16	25	0.31	7.75
	24	25	0.38	9.50

For SI: 1 inch = 25.4 mm.

**C402.1.5 Component performance alternative.** Building envelope values and fenestration areas determined in accordance with Equation 4-2 shall be ~~permitted in lieu of an alternative to compliance with the  $U$ -,  $F$ - and  $C$ -factors in Tables C402.1.4 and C402.4 and the maximum allowable fenestration areas in Section C402.4.1.~~ A version of IECC-2021 COMcheck with NC-specific amendments shall be permitted to demonstrate compliance. Fenestration shall meet the applicable SHGC requirements of Section C402.4.3.

$$A + B + C + D + E \leq \text{Zero} \quad \text{(Equation 4-2)}$$

where:

A = Sum of the (UA Dif) values for each distinct assembly type of the *building thermal envelope*, other than slabs on grade and below-grade walls.

UA Dif = UA Proposed – UA Table.

UA Proposed = Proposed  $U$ -value  $\times$  Area.

UA Table = ( $U$ -factor from Table C402.1.3, C402.1.4 or C402.4)  $\times$  Area.

B = Sum of the (FL Dif) values for each distinct slab-on-grade perimeter condition of the *building thermal envelope*.

FL Dif = FL Proposed – FL Table.

FL Proposed = Proposed  $F$ -value  $\times$  Perimeter length.

FL Table = ( $F$ -factor specified in Table C402.1.4)  $\times$  Perimeter length.

C = Sum of the (CA Dif) values for each distinct *below-grade wall* assembly type of the *building thermal envelope*.

CA Dif = CA Proposed – CA Table.

CA Proposed = Proposed C-value × Area.

CA Table = (Maximum allowable C-factor specified in Table C402.1.4) × Area.

Where the proposed vertical glazing area is less than or equal to the maximum vertical glazing area allowed by Section C402.4.1, the value of D (Excess Vertical Glazing Value) shall be zero. Otherwise:

D = (DA × UV) – (DA × U Wall), but not less than zero.

DA = (Proposed Vertical Glazing Area) – (Vertical Glazing Area allowed by Section C402.4.1).

UA Wall = Sum of the (UA Proposed) values for each opaque assembly of the exterior wall.

U Wall = Area-weighted average U-value of all above-grade wall assemblies.

UAV = Sum of the (UA Proposed) values for each vertical glazing assembly.

UV = UAV/total vertical glazing area.

Where the proposed skylight area is less than or equal to the skylight area allowed by Section C402.4.1, the value of E (Excess Skylight Value) shall be zero. Otherwise:

E = (EA × US) – (EA × U Roof), but not less than zero.

EA = (Proposed Skylight Area) – (Allowable Skylight Area as specified in Section C402.4.1).

U Roof = Area-weighted average U-value of all roof assemblies.

UAS = Sum of the (UA Proposed) values for each skylight assembly.

US = UAS/total skylight area.

**C402.2 Specific building thermal envelope insulation requirements. (Prescriptive).** Insulation in *building thermal envelope* opaque assemblies shall comply with Sections C402.2.1 through ~~C402.2.6~~C402.2.7 and Table C402.1.3.

~~**C402.2.1 Multiple layers of continuous insulation board.** Where two or more layers of continuous insulation board are used in a construction assembly, the continuous insulation boards shall be installed in accordance with Section C303.2. Where the continuous insulation board manufacturer's instructions do not address installation of two or more layers, the edge joints between each layer of continuous insulation boards shall be staggered.~~

**C402.2.1 Roof assembly.** The minimum thermal resistance (*R*-value) of the insulating material installed either between the roof framing or continuously on the roof assembly shall be as specified in Table C402.1.3, based on construction materials used in the roof assembly. □

**C402.2.1.1 Tapered, above-deck insulation based on thickness.** Where used as a component of a roof/ceiling assembly *R*-value calculation, the sloped roof insulation *R*-value contribution to that calculation shall use the average thickness in inches (mm) along with the material *R*-value-per-inch (per-mm) solely for *R*-value compliance as prescribed in Section 402.1.3.

**C402.2.1.2 Minimum thickness, lowest point.** The minimum thickness of above-deck roof insulation at its lowest point, gutter edge, roof drain or scupper, shall be not less than 1 inch (25 mm).

**C402.2.1.3 Suspended ceilings.** Insulation installed on suspended ceilings having removable ceiling tiles shall not be considered part of the minimum thermal resistance (*R*-value) of roof insulation in roof/ceiling construction.

**C402.2.1.4 Joints staggered.** Continuous insulation board shall be installed in not less than two layers and the edge joints between each layer of insulation shall be staggered, except where insulation tapers to the roof deck at a gutter edge, roof drain or scupper.

\*\* **C402.2.1.5 Skylight curbs.** Skylight curbs shall be insulated to the level of roofs with insulation entirely above the deck or R-5, whichever is less.



**\*\* Exception:** Unit skylight curbs included as a component of a skylight listed and labeled in accordance with NFRC 100 shall not be required to be insulated.

~~C402.2.2 Roof assembly.~~ The minimum thermal resistance ( $R$  value) of the insulating material installed either between the roof framing or continuously on the roof assembly shall be as specified in Table C402.1.3, based on construction materials used in the roof assembly. Skylight curbs shall be insulated to the level of roofs with insulation entirely above deck or  $R-5$ , whichever is less.

**Exceptions:**

- ~~1. Continuously insulated roof assemblies where the thickness of insulation varies 1 inch (25 mm) or less and where the area weighted  $U$  factor is equivalent to the same assembly with the  $R$  value specified in Table C402.1.3.~~
- ~~2. Where tapered insulation is used with insulation entirely above deck, the  $R$  value where the insulation thickness varies 1 inch (25 mm) or less from the minimum thickness of tapered insulation shall comply with the  $R$  value specified in Table C402.1.3.~~
- ~~3. Unit skylight curbs included as a component of a skylight listed and labeled in accordance with NFRC 100 shall not be required to be insulated.~~

~~Insulation installed on a suspended ceiling with removable ceiling tiles shall not be considered part of the minimum thermal resistance of the roof insulation.~~

~~C402.2.3 Thermal resistance of above-grade walls.~~ **C402.2.2 Above-grade walls.** The minimum thermal resistance ( $R$ -value) of insulating materials installed in the wall cavity between framing members and continuously on the walls shall be as specified in Table C402.1.3, based on framing type and construction materials used in the wall assembly. The  $R$ -value of integral insulation installed in concrete masonry units shall not be used in determining compliance with Table ~~C402.1.3.~~ C402.1.3 except as otherwise noted in the table. In determining compliance with Table C402.1.4, the use of the  $U$ -factor of concrete masonry units with integral insulation shall be permitted.

“Mass walls” shall include walls where used as a component in the thermal envelope of a building shall comply with one of the following:

- ~~Weighing~~ Weigh not less than 35 ~~psf~~ pounds per square foot (~~170~~171 kg/m<sup>2</sup>) of wall surface area.
- ~~Weighing~~ Weigh not less than 25 ~~pcf~~ pounds per cubic foot (~~120~~122 kg/m<sup>3</sup>) of wall surface area where the material weight is not more than 120 pcf (1900 kg/m<sup>3</sup>).
- ~~Having~~ Have a heat capacity exceeding 7 Btu/ft<sup>2</sup> × °F (144 kJ/m<sup>2</sup> × K).
- ~~Having~~ Have a heat capacity exceeding 5 Btu/ft<sup>2</sup> × °F (103 kJ/m<sup>2</sup> × K), where the material weight is not more than 120 pcf (1900 kg/m<sup>3</sup>).

~~C402.2.4~~ **C402.2.3 Floors.** The thermal properties (component  $R$ -values or assembly  $U$ -,  $C$ - or  $F$ -factors) of floor assemblies over outdoor air or unconditioned space shall be as specified in Table C402.1.3 or ~~Table~~ C402.1.4 based on the construction materials used in the floor assembly. Floor framing *cavity insulation* or structural slab insulation shall be installed to maintain permanent contact with the underside of the subfloor decking or structural slabs. ~~Mass floors shall include floors weighing not less than:~~

“Mass floors” where used as a component of the thermal envelope of a building shall provide one of the following weights:

- 35 pounds per square foot (171 kg/m<sup>2</sup>) of floor surface ~~area~~ area.
- 25 pounds per square foot (122 kg/m<sup>2</sup>) of floor surface area where the material weight is not more than 120 pounds per cubic foot (1923 kg/m<sup>3</sup>).

**Exceptions:**

- The floor framing *cavity insulation* or structural slab insulation shall be permitted to be in contact with the top side of sheathing or continuous insulation installed on the bottom side of floor assemblies where combined with insulation that meets or exceeds the minimum  $R$ -value in Table C402.1.3 for “Metal framed” or “Wood framed and other” values for “Walls, above grade” and extends from the bottom to the top of all perimeter floor framing or floor assembly members.

2. Insulation applied to the underside of concrete floor slabs shall be permitted an airspace of not more than 1 inch (25 mm) where it turns up and is in contact with the underside of the floor under walls associated with the *building thermal envelope*.

**C402.2.4 Slabs-on-grade.** The minimum thermal resistance (*R*-value) of the insulation for unheated or heated slab-on-grade floors designed in accordance with the *R*-value method of Section C402.1.3 shall be as specified in Table C402.1.3.

**C402.2.4.1 Insulation installation.** Where installed, the perimeter insulation shall be placed on the outside of the foundation or on the inside of the foundation wall. The perimeter insulation shall extend downward from the top of the slab for the minimum distance shown in the table or to the top of the footing, whichever is less, or downward to not less than the bottom of the slab and then horizontally to the interior or exterior for the total distance shown in the table. Insulation extending away from the building shall be protected by pavement or by not less than 10 inches (254 mm) of soil. Where installed, full slab insulation shall be continuous under the entire area of the slab-on-grade floor, except at structural column locations and service penetrations. Insulation required at the heated slab perimeter shall not be required to extend below the bottom of the heated slab and shall be continuous with the full slab insulation.

**Exception:** Where the slab-on-grade floor is greater than 24 inches (61 mm) below the finished exterior grade, perimeter insulation is not required.

~~**C402.2.5 Slabs on grade perimeter insulation.** Where the slab on grade is in contact with the ground, the minimum thermal resistance (*R* value) of the insulation around the perimeter of unheated or heated slab on grade floors designed in accordance with the *R* value method of Section C402.1.3 shall be as specified in Table C402.1.3. The insulation shall be placed on the outside of the foundation or on the inside of the foundation wall. The insulation shall extend downward from the top of the slab for a minimum distance as shown in the table or to the top of the footing, whichever is less, or downward to at least the bottom of the slab and then horizontally to the interior for the total distance shown in the table.~~

~~**Exception:** Where the slab on grade floor is greater than 24 inches (61 mm) below the finished exterior grade, perimeter insulation is not required.~~

**C402.2.5 Below-grade walls.** The *C*-factor for the below-grade exterior walls shall be in accordance with Table C402.1.4. The *R*-value of the insulating material installed continuously within or on the below-grade exterior walls of the building envelope shall be in accordance with Table C402.1.3. The *C*-factor or *R*-value required shall extend to a depth of not less than 10 feet (3048 mm) below the outside finished ground level, or to the level of the lowest floor of the conditioned space enclosed by the below-grade wall, whichever is less.

**C402.2.6 Insulation of radiant heating systems.** *Radiant heating system* panels, and their associated components that are installed in interior or exterior assemblies, shall be insulated with a minimum to an *R*-value of not less than  $R-3.5$  ( $0.62 \text{ m}^2\text{K/W}$ ) on all surfaces not facing the space being heated. *Radiant heating system* panels that are installed in the *building thermal envelope* shall be separated from the exterior of the building or unconditioned or exempt spaces by not less than the *R*-value of insulation installed in the opaque assembly in which they are installed or the assembly shall comply with Section C402.1.4.

**Exception:** Heated slabs on grade insulated in accordance with Section ~~C402.2.5~~C402.2.4.

~~**C402.2.7 Below grade walls.** The minimum thermal resistance (*R* value) of the insulating material installed in, or continuously on, the below-grade walls shall be as specified in Table C402.1.3, and shall extend to a depth of 10 feet (3048 mm) below the outside finished ground level, or to the level of the lowest floor, whichever is less.~~

**C402.2.7 Airspaces.** Where the *R*-value of an airspace is used for compliance in accordance with Section C402.1, the airspace shall be enclosed in an unventilated cavity constructed to minimize airflow into and out of the enclosed airspace. Airflow shall be deemed minimized where the enclosed airspace is located on the interior side of the continuous air barrier and is bounded on all sides by building components.

**Exception:** The thermal resistance of airspaces located on the exterior side of the continuous air barrier and adjacent to and behind the exterior wall-covering material shall be determined in accordance with ASTM C1363 modified with an airflow entering the bottom and exiting the top of the airspace at an air movement rate of not less than 70 mm/second.

**C402.3 Roof solar reflectance and thermal emittance.** Low-sloped roofs directly above cooled conditioned spaces in *Climate Zone 3* shall comply with one or more of the options in Table C402.3.

**Exceptions:** The following roofs and portions of roofs are exempt from the requirements of Table C402.3:

1. Portions of the roof that include or are covered by the following:
  - 1.1. Photovoltaic systems or components.

- 1.2. Solar air or water-heating systems or components.
- 1.3. ~~Roof gardens or landscaped roofs.~~ Vegetative roofs or landscaped roofs.
- 1.4. Above-roof decks or walkways.
- 1.5. Skylights.
- 1.6. HVAC systems and components, and other opaque objects mounted above the roof.
2. Portions of the roof shaded during the peak sun angle on the summer solstice by permanent features of the building or by permanent features of adjacent buildings.
3. Portions of roofs that are ballasted with a minimum stone ballast of 17 pounds per square foot (74 kg/m<sup>2</sup>) or 23 psf (117 kg/m<sup>2</sup>) pavers.
4. Roofs where not less than 75 percent of the roof area complies with one or more of the exceptions to this section.
5. ~~Metal building roofs.~~

**TABLE C402.3**

**MINIMUM ROOF REFLECTANCE AND EMITTANCE OPTIONS<sup>a</sup>**

Three-year-aged solar <del>reflectance</del> <del>reflectance</del> <sup>b</sup> <del>index</del> <sup>b</sup> of <del>0.55</del> <sup>55</sup> and 3-year aged thermal emittance <sup>c</sup> of 0.75
Three-year-aged solar reflectance index <sup>d</sup> of 64

- a. The use of area-weighted averages to comply with these requirements shall be permitted. Materials lacking 3-year-aged tested values for either solar reflectance or thermal emittance shall be assigned both a 3-year-aged solar reflectance in accordance with Section C402.3.1 and a 3-year-aged thermal emittance of 0.90.
- b. Aged solar reflectance tested in accordance with ASTM C1549, ASTM E903 or ASTM E1918 or ~~CRRC-1 Standard~~. CRRC-S100.
- c. Aged thermal emittance tested in accordance with ASTM C1371 or ASTM E408 or ~~CRRC-1 Standard~~. CRRC-S100.
- d. Solar reflectance index (SRI) shall be determined in accordance with ASTM E1980 using a convection coefficient of 2.1 Btu/h × ft<sup>2</sup> × °F (12 W/m<sup>2</sup> × K). Calculation of aged SRI shall be based on aged tested values of solar reflectance and thermal emittance.

**C402.3.1 Aged roof solar reflectance.** Where an aged solar reflectance required by Section C402.3 is not available, it shall be determined in accordance with Equation 4-3.

$$R_{aged} = [0.2 + 0.7(R_{initial} - 0.2)] \quad \text{(Equation 4-3)}$$

where:

$R_{aged}$  = The aged solar reflectance.

$R_{initial}$  = The initial solar reflectance determined in accordance with ~~CRRC-1~~. CRRC-S100 Standard.

**C402.4 Fenestration (Prescriptive) Fenestration.** Fenestration shall comply with Sections ~~C402.4~~ C402.4.1 through ~~C402.4.4~~ C402.4.5 and Table C402.4. Daylight responsive controls shall comply with this section and Section C405.2.4.

**TABLE C402.4  
BUILDING ENVELOPE FENESTRATION MAXIMUM U-FACTOR AND SHGC REQUIREMENTS**

CLIMATE ZONE	3	4	5
<b>Vertical Fenestration (30% maximum of above-grade wall)</b>			
<b>U-factor</b>			
<b>Framing materials other than metal with or without metal reinforcement or cladding</b>			
U-Factor	0.32	0.32	0.30
<b>Metal framing with or without thermal break</b>			
Curtain Wall/Storefront U-Factor	0.45	0.45	0.38
Entrance Door U-Factor	0.77	0.77	0.77
All Other U-Factor <sup>a</sup>	0.45	0.45	0.45
<b>SHGC—All Frame Types</b>			
SHGC: PF < 0.25	0.25	0.25	0.40
SHGC: 0.25 ≤ PF < 0.5	0.33	0.33	NR
SHGC: PF ≥ 0.5	0.40	0.40	NR
<b>Skylights (3% maximum)</b>			
U-factor	0.60	0.60	0.60
SHGC	0.35	0.35	0.40

SHGC = Solar Heat Gain Coefficient. (approximately equal to 0.87 times the Shading Coefficient).

NR = No requirement. PF = Projection factor. (See Section C402.4.3).

a. All others include operable windows, fixed and nonentrance doors.

**TABLE C402.4  
BUILDING ENVELOPE FENESTRATION MAXIMUM U-FACTOR AND SHGC<sup>a</sup> REQUIREMENTS**

CLIMATE ZONE	3	4	5
<b>Vertical fenestration</b>			
<b>U-factor</b>			
Fixed fenestration	0.42	0.36	0.36
Operable fenestration	0.54	0.45	0.45
Entrance doors	0.68	0.63	0.63
<b>SHGC</b>			
Fixed fenestration	0.25	0.36	0.38
Operable fenestration	0.23	0.33	0.33
<b>Skylights</b>			
U-factor	0.55	0.50	0.50
SHGC	0.30	0.40	0.40

<sup>a</sup>. C402.4.1.3 shall apply

**C402.4.1 Maximum area.** The vertical fenestration area (not including opaque doors and opaque spandrel panels) area, not including opaque doors and opaque spandrel panels, shall be not be greater than 30 percent of the gross above-grade wall area. The skylight area shall be not greater than 3 percent of the gross roof area.

**C402.4.1.1 Increased vertical fenestration area with daylight responsive controls.** Deleted.

**C402.4.1.2 Increased skylight area with daylight responsive controls.** Deleted.

**C402.4.1.3 Maximum Area by Orientation** Vertical fenestration shall comply with not less than one of the following:

1.  $\text{Area}_{\text{east}} \leq 0.25 \times \text{Area}_{\text{total}}$  and  $\text{Area}_{\text{west}} \leq 0.25 \times \text{Area}_{\text{total}}$
2.  $\text{Area}_{\text{east}} \times \text{SHGC}_{\text{east}} \leq 0.25 \times \text{Area}_{\text{total}} \times \text{SHGC}_{\text{table}}$  and  $\text{Area}_{\text{west}} \times \text{SHGC}_{\text{west}} \leq 0.25 \times \text{Area}_{\text{total}} \times \text{SHGC}_{\text{table}}$

where

$\text{Area}_{\text{east}}$  is the total vertical fenestration area oriented within 45 degrees of true east to the south and 22.5 degrees of true east to the north

$\text{Area}_{\text{west}}$  is the total vertical fenestration area oriented within 45 degrees of true west to the south and 22.5 degrees of true west to the north

$\text{Area}_{\text{total}}$  is the total vertical fenestration area of the building

$\text{SHGC}_{\text{east}}$  is the maximum Solar Heat Gain Coefficient of  $\text{Area}_{\text{east}}$  of the building

$\text{SHGC}_{\text{west}}$  is the maximum Solar Heat Gain Coefficient of  $\text{Area}_{\text{west}}$  of the building

$\text{SHGC}_{\text{table}}$  is the maximum Solar Heat Gain Coefficient in Table C402.4 for the building climate zone

**C402.4.2 Minimum skylight fenestration area.** Deleted.

**C402.4.2 Lighting controls in toplit daylight zones.** *Daylight responsive controls* shall be provided in toplit daylight zones.

**C402.4.2.1 Lighting controls in daylight zones under skylights.** Deleted.

**C402.4.2.2 Haze factor.** Deleted. Skylights in office, storage, automotive service, manufacturing, nonrefrigerated warehouse, retail store and distribution/sorting area spaces shall have a glazing material or diffuser with a haze factor greater than 90 percent when tested in accordance with ASTM D1003.

**Exception:** Skylights and tubular daylighting devices designed and installed to exclude direct sunlight entering the occupied space by the use of fixed or automated baffles, the geometry of skylight and light well or the use of optical diffuser components.

**C402.4.3 Maximum U-factor and SHGC.** The maximum U-factor and solar heat gain coefficient (SHGC) for fenestration shall be as specified in Table C402.4.

The window projection factor shall be determined in accordance with Equation 4-5.

$$PF = A/B \quad \text{(Equation 4-5)}$$

where:

$PF$  = Projection factor (decimal).

$A$  = Distance measured horizontally from the farthest continuous extremity of any overhang, eave or permanently attached shading device to the vertical surface of the glazing.

$B$  = Distance measured vertically from the bottom of the glazing to the underside of the overhang, eave or permanently attached shading device.

Where different windows or glass doors have different  $PF$  values, they shall each be evaluated separately.

**C402.4.3.1 Increased skylight SHGC.** Deleted.

**C402.4.3.2 Increased skylight U-factor.** Deleted.

**C402.4.3.3C402.4.3.1 Dynamic glazing.** Where dynamic glazing is intended to satisfy the SHGC and VT requirements of Table C402.4, the ratio of the higher to lower labeled SHGC shall be greater than or equal to 2.4, and the *dynamic glazing* shall be automatically controlled to modulate the amount of solar gain into the space in multiple steps. Dynamic glazing shall be considered separately from other fenestration, and area-weighted averaging with other fenestration that is not dynamic glazing shall not be permitted.

**Exception:** Dynamic glazing is not required to comply with this section where both the lower and higher labeled SHGC already comply with the requirements of Table C402.4.

**C402.4.3.4C402.4.3.2 Area-weighted U-factor.** An area-weighted average shall be permitted to satisfy the *U*-factor requirements for each fenestration product category listed in Table C402.4. Individual fenestration products from different fenestration product categories listed in Table C402.4 shall not be combined in calculating area-weighted average *U*-factor.

**C402.4.4 Doors.** *Opaque doors* shall comply with the applicable requirements for doors as specified in Table C402.1.3 and be considered part of the gross area of above grade walls that are part of the building *thermal envelope*. Other doors shall comply with the provisions of Section C402.4.3 for vertical fenestration.

**C402.4.4 Daylight zones.** Daylight zones shall comply with Sections C405.2.4.2 and C405.2.4.3, as applicable. Daylight zones shall include *toplit daylight zones* and daylight sidelit zones.

**C402.4.5 Doors.** Opaque swinging doors shall comply with Table C402.1.4. Opaque nonswinging doors shall comply with Table C402.1.4. Opaque doors shall be considered as part of the gross area of above-grade walls that are part of the *building thermal envelope*. Opaque doors shall comply with Section C402.4.5.1 or C402.4.5.2. Other doors shall comply with the provisions of Section C402.4.3 for vertical fenestration.

**C402.4.5.1 Opaque swinging doors.** Opaque swinging doors shall comply with Table C402.1.4.

**C402.4.5.2 Nonswinging doors.** Opaque nonswinging doors that are horizontally hinged sectional doors with a single row of fenestration shall have an assembly *U*-factor less than or equal to 0.440 in Climate Zones 0 through 6 and less than or equal to 0.360 in Climate Zones 7 and 8, provided that the fenestration area is not less than 14 percent and not more than 25 percent of the total door area.

**Exception:** Other doors shall comply with the provisions of Section C402.4.3 for vertical fenestration.

**C402.5 Air leakage—thermal envelope (Mandatory).** The *thermal envelope* of buildings shall comply with Sections C402.5.1 through C402.5.8, or the building *thermal envelope* shall be tested in accordance with ASTM E779 at a pressure differential of 0.3 inch water gauge (75 Pa) and deemed to comply with the provisions of this section when the tested air leakage rate of the building *thermal envelope* is not greater than 0.40 cfm/ft<sup>2</sup> (2.0 L/s · m<sup>2</sup>). Where compliance is based on such testing, the building shall also comply with Sections C402.5.5, C402.5.6 and C402.5.7.

**C402.5 Air leakage—building thermal envelope.** The *building thermal envelope* shall comply with Sections C402.5.1 through Section C402.5.8.1.

**C402.5.1 Air barriers.** A continuous air barrier shall be provided throughout the building *thermal envelope*. The air barriers shall be permitted to be located on the inside or outside of the building envelope, located within the assemblies composing the envelope, or any combination thereof. The air barrier shall comply with Sections C402.5.1.1 and C402.5.1.2. A continuous *air barrier* shall be provided throughout the *building thermal envelope*. The air barrier is permitted to be any combination of inside, outside or within the building *thermal envelope*. The air barrier shall comply with Sections C402.5.1.1, and C402.5.1.2. The *air leakage* performance of the air barrier shall be verified in accordance with Section C402.5.2.

**C402.5.1.1 Air barrier construction.** The *continuous air barrier* shall be constructed to comply with the following:

1. The air barrier shall be continuous for all assemblies that are the *thermal envelope* of the building and across the joints and assemblies.
2. Air barrier joints and seams shall be sealed, including sealing transitions in places and changes in materials. The joints and seals shall be securely installed in or on the joint for its entire length so as not to dislodge, loosen or otherwise impair its ability to resist positive and negative pressure from wind, stack effect and mechanical ventilation.
3. Penetrations of the air barrier shall be caulked, gasketed or otherwise sealed in a manner compatible with the construction materials and location. Joints and seals associated with penetrations shall be sealed in the same manner or taped or covered with moisture vapor permeable wrapping material. Sealing materials shall be appropriate to the construction materials being sealed and shall be securely installed around the penetration so as not to dislodge, loosen or otherwise impair the penetrations' ability to resist positive and negative pressure from wind, stack effect and mechanical ventilation. Sealing of concealed fire sprinklers, where required, shall be in a manner that is recommended by the manufacturer. Caulking or other adhesive sealants shall not be used to fill voids between fire sprinkler cover plates and walls or ceilings.
4. Recessed lighting fixtures shall comply with Section C402.5.8. Where similar objects are installed that penetrate the air barrier, provisions shall be made to maintain the integrity of the air barrier.

**C402.5.1.1 Air barrier design and documentation requirements.** Design of the continuous *air barrier* shall be documented in the following manner:

1. Components comprising the continuous *air barrier* and their position within each *building thermal envelope* assembly shall be identified.
2. Joints, interconnections, and penetrations of the continuous *air barrier* components shall be detailed.
3. The continuity of the *air barrier* building element assemblies that enclose conditioned space or provide a boundary between conditioned space and unconditioned space shall be identified.
4. Documentation of the continuous air barrier shall detail methods of sealing the air barrier such as wrapping, caulking, gasketing, taping or other *approved* methods at the following locations:
  - 4.1. Joints around fenestration and door frames.
  - 4.2. Joints between walls and floors, between walls at building corners, between walls and roofs including parapets and copings, where above-grade walls meet foundations, and similar intersections.
  - 4.3. Penetrations or attachments through the continuous *air barrier* in building envelope roofs, walls, and floors.
  - 4.4. Building assemblies used as ducts or plenums.
  - 4.5. Changes in continuous *air barrier* materials and assemblies.
5. Identify where testing will or will not be performed in accordance with Section C402.5.2. Where testing will not be performed, a plan for field inspections required by C402.5.2.3 shall be provided that includes the following:
  - 5.1 Schedule for periodic inspection.
  - 5.2 Continuous air barrier scope of work.
  - 5.3 List of critical inspection items.
  - 5.4 Inspection documentation requirements, and
  - 5.5 Provisions for corrective actions where needed.

~~C402.5.1.2 Air barrier compliance options.~~ A continuous air barrier for the opaque building thermal envelope shall comply with Section C402.5.1.2.1 or C402.5.1.2.2.

**C402.5.1.2 Air barrier construction.** The *continuous air barrier* shall be constructed to comply with the following:

1. The *air barrier* shall be continuous for all assemblies that comprise the *building thermal envelope* and across the joints and assemblies.
2. Air barrier joints and seams shall be sealed, including sealing transitions in places and changes in materials. The joints and seals shall be securely installed in or on the joint for its entire length so as not to dislodge, loosen or otherwise impair its ability to resist positive and negative pressure differentials such as those from design wind loads, stack effect and mechanical ventilation.
3. Penetrations of the *air barrier* shall be caulked, gasketed or otherwise sealed in a manner compatible with the construction materials and location. Sealing shall allow for expansion, contraction and mechanical vibration. Sealing materials shall be securely installed around the penetration so as not to dislodge, loosen or otherwise impair the penetrations' ability to resist positive and negative pressure. Sealing of concealed fire sprinklers, where required, shall be in a manner that is recommended by the fire sprinkler manufacturer. Caulking or other adhesive sealants shall not be used to fill voids between fire sprinkler cover plates and walls or ceilings.
4. Recessed lighting fixtures shall comply with Section C402.5.1.2.1. Where similar objects are installed that penetrate the *air barrier*, provisions shall be made to maintain the integrity of the *air barrier*.
5. Electrical and communication boxes shall comply with C402.5.1.2.2.

~~C402.5.8~~**C402.5.1.2.1 Recessed lighting.** Recessed luminaires installed in the *building thermal envelope* shall be all of the following:

1. IC-rated.
2. Labeled as having an air leakage rate of not ~~more~~greater than 2.0 cfm (0.944 L/s) ~~when~~where tested in accordance with ASTM E283 at a 1.57 psf (75 Pa) pressure differential.
3. Sealed with a gasket or caulk between the housing and interior wall or ceiling covering.

**C402.5.1.2.2 Electrical and communication boxes.** Electrical and communication boxes that penetrate the *air barrier* of the building thermal envelope, and that do not comply with C402.5.1.2.2.1, shall be caulked, taped, gasketed, or otherwise sealed to the air barrier element being penetrated. All openings on the

concealed portion of the box shall be sealed. Where present, insulation shall rest against all concealed portions of the box.

**C402.5.1.2.2.1 Air-sealed boxes.** Where air-sealed boxes are installed, they shall be marked in accordance with NEMA OS 4. Air-sealed boxes shall be installed in accordance with the manufacturer's instructions.

**C402.5.1.3 Materials.** Deleted. Refer to **C402.5.2.3.1**

**C402.5.1.4 Assemblies.** Deleted. Refer to **C402.5.2.3.2**

**C402.5.1.5 Building envelope performance verification.** The installation of the continuous air barrier shall be verified by the *code official*, a *registered design professional* or *approved agency* in accordance with the following:

1. A review of the construction documents and other supporting data shall be conducted to assess compliance with the requirements in Section C402.5.1.
2. Inspection of continuous air barrier components and assemblies shall be conducted during construction while the air barrier is still accessible for inspection and repair to verify compliance with the requirements of Sections C402.5.2.3.1 and C402.5.2.3.2.
3. A final commissioning report shall be provided for inspections completed by the *registered design professional* or *approved agency*. The commissioning report shall be provided to the building owner or owner's authorized agent and the *code official*. The report shall identify deficiencies found during the review of the construction documents and inspection and details of corrective measures taken.

**C402.5.2 Air leakage compliance.** *Air leakage of the building thermal envelope shall be tested by an approved third party in accordance with C402.5.2.1. The measured air leakage shall not be greater than 0.35 cfm/ft<sup>2</sup> (1.8 L/s × m<sup>2</sup>) of the building thermal envelope area at a pressure differential of 0.3 inch water gauge (75 Pa) with the calculated building thermal envelope surface area being the sum of the above- and below-grade building thermal envelope.*

**Exceptions:**

1. Where the measured air leakage rate is greater than 0.35 cfm/ft<sup>2</sup> (1.8 L/s × m<sup>2</sup>) but is not greater than 0.45 cfm/ft<sup>2</sup> (2.3 L/s × m<sup>2</sup>), the approved third party shall perform a diagnostic evaluation using smoke tracer or infrared imaging. The evaluation shall be conducted while the building is pressurized along with a visual inspection of the air barrier in accordance with ASTM E1186. All identified leaks shall be sealed where such sealing can be made without damaging existing building components. A report specifying the corrective actions taken to seal leaks shall be deemed to establish compliance with the requirements of this section where submitted to the code official and the building owner. Where the measured air leakage rate is greater than 0.45 cfm/ft<sup>2</sup> (2.3 L/s × m<sup>2</sup>), corrective actions must be made to the building and an additional test completed for which the results are 0.45 cfm/ft<sup>2</sup> (2.3 L/s × m<sup>2</sup>), or less.
2. Buildings larger than 25,000 square feet (2300 m<sup>2</sup>) floor area in Climate Zones 3 and 4, other than Group R and I occupancies, that comply with C402.5.2.3.
3. As an alternative, buildings or portions of buildings, containing Group R and I occupancies, shall be permitted to be tested by an approved third party in accordance with C402.5.2.2. The reported air leakage of the building thermal envelope shall not be greater than 0.27 cfm/ft<sup>2</sup> (1.4 L/s × m<sup>2</sup>) of the testing unit enclosure area at a pressure differential of 0.2 inch water gauge (50 Pa), or 0.36 cfm/ft<sup>2</sup> at a pressure differential of 75Pa (0.30 in. w.g.) in accordance with pressure/leakage correlation Table C402.5.2.

**Table C402.5.2 Pressure/leakage correlation Table C402.5.2.**

Pressure Differential (Pa)	Test pressure Adjustment Factor	Max Air Leakage / Building Thermal Envelope (CFM / ft <sup>2</sup> )		
		0.27	0.28	0.30
75 (0.30 in. w.g.)		0.36	0.37	0.40
50 (0.20 in. w.g.)	0.752897957	0.27	0.28	0.30

Example: If maximum air leakage allowed is 0.27 cfm/ft<sup>2</sup> of bldg thermal envelope at 50 Pa(0.2 in w.g.), the corresponding maximum leakage rate is 0.36 cfm/SF of bldg thermal envelope if using a higher test pressure of 75 Pa(0.3 in w.g.)



**C402.5.2.1 Whole building test method and reporting.** The building thermal envelope shall be tested for air leakage in accordance with ASTM E3158 or an equivalent approved method. A report that includes the tested surface area, floor area, air by volume, stories above grade, and leakage rates shall be submitted to the code official and the building owner.

**Exceptions:**

1. For buildings less than 10,000 ft<sup>2</sup> (1000 m<sup>2</sup>) the entire building thermal envelope shall be permitted to be tested in accordance with ASTM E779, ASTM E3158 or ASTM E1827 or an equivalent approved method.
2. For buildings greater than 50,000 ft<sup>2</sup> (4645 m<sup>2</sup>), portions of the building shall be permitted to be tested and the measured air leakage shall be area-weighted by the surface areas of the building thermal envelope in each portion. The weighted average tested air leakage shall not be greater than the whole building leakage limit. The following portions of the building shall be tested:
  - 2.1 The entire building thermal envelope area of stories that have any conditioned spaces directly under a roof.
  - 2.2 The entire building thermal envelope area of stories that have a building entrance, a floor over unconditioned space, a loading dock, or that are below grade.
  - 2.3 Representative above-grade portions of the building totaling not less than 25 percent of the wall area enclosing the remaining conditioned space.

**C402.5.2.2 Dwelling and sleeping unit enclosure test method and reporting.** The building thermal envelope shall be tested for air leakage in accordance with ASTM E779, ANSI/RESNET/ICC 380, ASTM E1827 or an equivalent approved method. Where multiple dwelling units or sleeping units or other enclosed spaces are contained within one building thermal envelope, each shall be considered an individual testing unit, and the building air leakage shall be the weighted average of all tested unit results, weighted by each testing unit enclosure area. Units shall be tested without simultaneously pressuring adjacent units and shall be separately tested as follows:

1. Where buildings have less than eight total dwelling or sleeping units, each unit shall be tested.
2. Where buildings have eight or more testing units, the greater of seven units or 20 percent of the testing units in the building shall be tested, including a top floor unit, a middle floor unit, a ground floor unit and a unit with the largest testing unit enclosure area. For each tested unit that exceeds the maximum air leakage rate, an additional three units shall be tested, including a mixture of unit types and locations.

**C402.5.2.3 Building envelope design and construction verification criteria.** Where Sections C402.5.2.1 and C402.5.2.2 are not applicable, the installation of the continuous air barrier shall be verified by the code official, a registered design professional or approved agency in accordance with the following:

1. A review of the construction documents and other supporting data shall be conducted to assess compliance with the requirements in Section C402.5.1.
2. Inspection of continuous air barrier components and assemblies shall be conducted during construction to verify compliance with the requirements of Sections C402.5.2.3.1 or C402.5.2.3.2. The air barrier shall remain accessible for inspection and repair.
3. A final inspection report shall be provided for inspections completed by the registered design professional or approved agency. The inspection report shall be provided to the building owner or owner's authorized agent and the code official. The report shall identify deficiencies found during inspection and details of corrective measures taken.

**C402.5.1.2.1-C402.5.2.3.1 Materials.** Materials with an air permeability not greater than 0.004 cfm/ft<sup>2</sup> (0.02 L/s × m<sup>2</sup>) under a pressure differential of 0.3 inch water gauge (75 Pa) when tested in accordance with ASTM E2178 shall comply with this section. Materials in Items 1 through 16 shall be deemed to comply with this section, provided that joints are sealed and materials are installed as air barriers in accordance with the manufacturer's instructions.

1. Plywood with a thickness of not less than 3/8 inch (10 mm).
2. Oriented strand board having a thickness of not less than 3/8 inch (10 mm).
3. Extruded polystyrene insulation board having a thickness of not less than 1/2 inch (12.7 mm).

4. Foil-back polyisocyanurate insulation board having a thickness of not less than 1½inch (12.7 mm).
5. Closed-cell spray foam having a minimum density of 1.5 pcf (2.4 kg/m³) and having a thickness of not less than 1½ inches (38 mm).
6. Open-cell spray foam with a density between 0.4 and 1.5 pcf (0.6 and 2.4 kg/m³) and having a thickness of not less than 4.5 inches (113 mm).
7. Exterior or interior gypsum board having a thickness of not less than 1½inch (12.7 mm).
8. Cement board having a thickness of not less than 1½inch (12.7 mm).
9. Built-up roofing membrane.
10. Modified bituminous roof membrane.
11. ~~Fully adhered single ply~~Single-ply roof membrane.
12. A Portland cement/sand parge, or gypsum plaster having a thickness of not less than 5⁄8 inch (15.9 mm).
13. Cast-in-place and precast concrete.
14. Fully grouted concrete block masonry.
15. Sheet steel or aluminum.
16. Solid or hollow masonry constructed of clay or shale masonry units.

~~C402.5.1.2.2~~**C402.5.2.3.2 Assemblies.** Assemblies of materials and components with an average air leakage not greater than 0.04 cfm/ft² (0.2 L/s × m²) under a pressure differential of 0.3 inch of water gauge (w.g.)(75 Pa) when tested in accordance with ASTM E2357, ASTM E1677, ~~ASTM D8052~~ or ASTM E283 shall comply with this section. Assemblies listed in Items 1 through 3 shall be deemed to comply, provided that joints are sealed and the requirements of Section C402.5.1.1 are met.

1. Concrete masonry walls coated with either one application of block filler or two applications of a paint or sealer coating.
2. Masonry walls constructed of clay or shale masonry units with a nominal width ~~of greater than or equal to 4 inches (102 mm) or more.~~(102 mm).
3. A Portland cement/sand parge, stucco or plaster not less than 1½ inch (12.7 mm) in thickness.

~~C402.5.3 Rooms containing fuel burning appliances.~~ Deleted.

~~C402.5.2~~**C402.5.3 Air leakage of fenestration.** ~~The air leakage of fenestration assemblies shall meet the provisions of Table C402.5.2. Testing shall be in accordance with the applicable reference test standard in Table C402.5.2 by an accredited, independent testing laboratory and labeled by the manufacturer.~~The air leakage of fenestration assemblies shall comply with Table C402.5.3. Testing shall be conducted by an accredited, independent testing laboratory in accordance with the applicable reference test standard in Table C402.5.3 and labeled by the manufacturer.

**Exceptions:**

1. Field-fabricated fenestration assemblies that are sealed in accordance with Section ~~C402.5.1~~C402.5.1.2.
2. ~~Fenestration in buildings that comply with the testing alternative of Section C402.5 are not required to meet the air leakage requirements in Table C402.5.2.~~Fenestration in buildings that are tested for air leakage of in accordance with Section C402.5.2 are not required to meet the air leakage requirements in Table C402.5.3.

~~TABLE C402.5.2~~**Table C402.5.3**

**MAXIMUM AIR LEAKAGE RATE FOR FENESTRATION ASSEMBLIES**

FENESTRATION ASSEMBLY	MAXIMUM RATE (CFM/FT²)	TEST PROCEDURE
Windows	0.20 <sup>a</sup>	AAMA/WDMA/CSA101/I.S.2/A440 or NFRC 400
Sliding doors	0.20 <sup>a</sup>	

Swinging doors	0.20 <sup>a</sup>	
Skylights—with condensation weepage openings	0.30	
Skylights—all other	0.20 <sup>a</sup>	
Curtain walls	0.06	NFRC 400 or ASTM E283 at 1.57 psf (75 Pa)
Storefront glazing	0.06	
Commercial glazed swinging entrance doors	1.00	
<u>Power-operated sliding doors and power operated folding doors</u>	<u>1.00</u>	
Revolving doors	1.00	
Garage doors	0.40	ANSI/DASMA 105, NFRC 400, or ASTM E283 at 1.57 psf (75 Pa)
Rolling doors	1.00	
High-speed doors	1.30	

For SI: 1 cubic foot per minute = 0.47 L/s, 1 square foot = 0.093 m<sup>2</sup>.

a. The maximum rate for windows, sliding and swinging doors, and skylights is permitted to be 0.3 cfm per square foot of fenestration or door area when tested in accordance with AAMA/WDMA/CSA1011/S.2/A440 at 6.24 psf (300 Pa).

**C402.5.4 Doors and access openings to shafts, chutes, stairways and elevator lobbies.** ~~Deleted.~~ Doors and access openings from conditioned space to shafts, chutes stairways and elevator lobbies not within the scope of the fenestration assemblies covered by Section C402.5.3 shall be gasketed, weather-stripped or sealed.

**Exceptions:**

1. Door openings required to comply with Section 716 of the *International Building Code*.
2. Doors and door openings required by the *International Building Code* to comply with UL 1784.

**C402.5.5 Air intakes, exhaust openings, stairways and shafts.** Stairway enclosures, elevator shaft vents and other outdoor air intakes and exhaust openings integral to the building envelope shall be provided with dampers in accordance with Section ~~C403.2.4.3~~ C403.7.7.

~~C402.5.7~~ **C402.5.6 Vestibules.** Building entrances shall be protected with an enclosed vestibule, with all doors opening into and out of the vestibule equipped with self-closing devices. Vestibules shall be designed so that in passing through the vestibule it is not necessary for the interior and exterior doors to open at the same time. The installation of one or more revolving doors in the *building entrance* shall not eliminate the requirement that a vestibule be provided on any doors adjacent to revolving doors.

**Exceptions:** Vestibules are not required for the following:

1. Deleted.
2. Doors not intended to be used by the public, such as doors to mechanical or electrical equipment rooms, or intended solely for employee use.
3. Doors opening directly from a *sleeping unit* or dwelling unit.
4. Doors that open directly from a space less than 3,000 square feet (298 m<sup>2</sup>) in area.
5. Revolving doors.
6. Doors used primarily to facilitate vehicular movement or material handling and adjacent personnel doors.
7. Doors that have an air curtain with a velocity of not less than 6.56 feet per second (2 m/s) at the floor that have been tested in accordance with ANSI/AMCA 220 and installed in accordance with the manufacturer's instructions.

Manual or automatic controls shall be provided that will operate the air curtain with the opening and closing of the door. Air curtains and their controls shall comply with Section C408.2.3.

- ~~8. Building entrances in buildings that are less than four stories above grade and less than 10,000 square feet (929 m<sup>2</sup>) in floor area.~~

~~C402.5.6~~**C402.5.7 Loading dock weather seals.** Cargo door openings and loading dock doors shall be equipped with weather seals that restrict infiltration when air leakage and provide direct contact along the top and sides of vehicles that are parked in the doorway.

**C402.5.8 Operable openings interlocking.** Where occupancies utilize operable openings to the outdoors that are larger than 40 square feet (3.7 m<sup>2</sup>) in area, such openings shall be interlocked with the heating and cooling system to raise the cooling setpoint to 90°F (32°C) and lower the heating setpoint to 55°F (13°C) whenever the operable opening is open. The change in heating and cooling setpoints shall occur when the operable opening has been open for a period not to exceed 10 minutes.

**Exceptions:**

1. Operable openings into separately zoned areas associated with the preparation of food that contain appliances that contribute to the HVAC loads of a restaurant or similar type of occupancy.
2. Storage occupancies that utilize overhead doors for the function of the occupancy, where approved.
3. Doors located in the exterior wall that are part of a vestibule system.

**C402.5.8.1 Operable controls.** Controls shall comply with Section C403.13.

**SECTION C403  
BUILDING MECHANICAL SYSTEMS**

**C403.1 General.** Mechanical systems and equipment serving the building heating, ~~cooling or cooling,~~ ventilating or refrigerating needs shall comply with ~~Section C403.2 and shall comply with Sections C403.3 and C403.4 based on the equipment and systems provided this section.~~

**Exception:** Data center systems are exempt from the requirements of Sections C403.4 and C403.5.

~~C403.2.1~~**C403.1.1 Calculation of heating and cooling loads.** Design loads associated with heating, ventilating and air conditioning of the building shall be determined in accordance with ANSI/ASHRAE/ACCA Standard 183 or by an *approved* equivalent computational procedure using the design parameters specified in Chapter 3. Heating and cooling loads shall be adjusted to account for load reductions that are achieved where energy recovery systems are utilized in the HVAC system ~~except for hospitals and patient care facilities~~ in accordance with the ASHRAE HVAC Systems and Equipment Handbook by an approved equivalent computational procedure.

**C403.1.2 Data centers.** Data center systems shall comply with Sections 6 and 8 of ASHRAE 90.4 with the following changes:

1. Replace design mechanical load component (MLC) values specified in Table 6.2.1.1 of the ASHRAE 90.4 with the values in Table C403.1.2(1) as applicable in each climate zone.
2. Replace annualized MLC values specified in Table 6.2.1.2 of the ASHRAE 90.4 with the values in Table C403.1.2(2) as applicable in each climate zone.

**TABLE C403.1.2(1)  
MAXIMUM DESIGN MECHANICAL LOAD COMPONENT  
(DESIGN MLC)**

CLIMATE ZONE	DESIGN MLC AT 100% AND AT 50% ITE LOAD
<u>3A</u>	<u>0.23</u>
<u>4A</u>	<u>0.23</u>
<u>5A</u>	<u>0.22</u>

**TABLE C403.1.2(2)**  
**MAXIMUM ANNUALIZED MECHANICAL LOAD COMPONENT (ANNUALIZED MLC)**

CLIMATE ZONE	HVAC MAXIMUM ANNUALIZED MLC AT 100% AND AT 50% ITE LOAD
<u>3A</u>	<u>0.18</u>
<u>4A</u>	<u>0.17</u>
<u>5A</u>	<u>0.17</u>

**C403.2 Provisions applicable to all mechanical systems (Mandatory)-System design.** Mechanical systems and equipment serving the building heating, cooling or ventilating needs shall comply with Sections C403.2.1 through C403.2.13. Mechanical systems shall be designed to comply with Sections C403.2.1 through C403.2.3. Where elements of a building's mechanical systems are addressed in Sections C403.3 through C403.14, such elements shall comply with the applicable provisions of those sections.

~~C403.2.4.4 Zone isolation.~~ Deleted. **C403.2.1 Zone isolation required.** HVAC systems serving zones that are over 25,000 square feet (2323 m<sup>2</sup>) in floor area or that span more than one floor and are designed to operate or be occupied nonsimultaneously shall be divided into isolation areas. Each isolation area shall be equipped with *isolation devices* and controls configured to automatically shut off the supply of conditioned air and outdoor air to and exhaust air from the isolation area. Each isolation area shall be controlled independently by a device meeting the requirements of Section C403.4.2.2. Central systems and plants shall be provided with controls and devices that will allow system and equipment operation for any length of time while serving only the smallest isolation area served by the system or plant.

**Exceptions:**

1. Exhaust air and outdoor air connections to isolation areas where the fan system to which they connect is not greater than 5,000 cfm (2360 L/s).
2. Exhaust airflow from a single isolation area of less than 10 percent of the design airflow of the exhaust system to which it connects.
3. Isolation areas intended to operate continuously or intended to be inoperative only when all other isolation areas in a zone are inoperative.

~~C403.2.6~~ **C403.2.2 Ventilation.** Ventilation, either natural or mechanical, shall be provided in accordance with Chapter 4 of the *International Mechanical Code*. ~~Where mechanical ventilation is provided, the system shall provide the capability to reduce the outdoor air supply to the minimum required by Chapter 4 of the *International Mechanical Code*.~~

**C403.2.3 Fault detection and diagnostics.** New buildings with an HVAC system serving a gross conditioned floor area of 20,000 square feet (9290 m<sup>2</sup>) or larger shall include a fault detection and diagnostics (FDD) system to monitor the HVAC system's performance and automatically identify faults. The FDD system shall:

1. Include permanently installed sensors and devices to monitor the HVAC system's performance.
2. Deleted.
3. Automatically identify and report HVAC system faults.
4. Automatically notify authorized personnel of identified HVAC system faults.
5. Automatically provide prioritized recommendations for repair of identified faults based on analysis of data collected from the sampling of HVAC system performance.
6. Be capable of transmitting the prioritized fault repair recommendations to remotely located authorized personnel.

**Exception:** R-1 and R-2 occupancies.

**C403.3 Heating and cooling equipment efficiencies.** Heating and cooling equipment installed in mechanical systems shall be sized in accordance with Section C403.3.1 and shall be not less efficient in the use of energy than as specified in Section C403.3.2.

~~€403.2.2~~**C403.3.1 Equipment sizing.** The output capacity of heating and cooling equipment shall be not greater than that of the smallest available equipment size that exceeds the loads calculated in accordance with Section ~~€403.2.1, within available equipment options.~~C403.1.1. A single piece of equipment providing both heating and cooling shall satisfy this provision for one function with the capacity for the other function as small as possible, within available equipment options.

**Exceptions:**

1. Required standby equipment and systems provided with controls and devices that allow such systems or equipment to operate automatically only when the primary equipment is not operating.
2. Multiple units of the same equipment type with combined capacities exceeding the design load and provided with controls that are configured to sequence the operation of each unit based on load.
3. ~~When the equipment selected is the smallest size needed to meet the load within available options of the desired equipment line.~~

~~€403.2.3~~**C403.3.2 HVAC equipment performance requirements.** Equipment shall meet the minimum efficiency requirements of Tables ~~€403.2.3(1), €403.2.3(2), €403.2.3(3), €403.2.3(4), €403.2.3(5), €403.2.3(6), €403.2.3(7), €403.2.3(8) and €403.2.3(9)~~C403.3.2(1) through C403.3.2(16) when tested and rated in accordance with the applicable test procedure. Plate-type liquid-to-liquid heat exchangers shall meet the minimum requirements of AHRI 400. The efficiency shall be verified through certification under an approved certification program or, where a certification program does not exist, the equipment efficiency ratings shall be supported by data furnished by the manufacturer. Where multiple rating conditions or performance requirements are provided, the equipment shall satisfy all stated requirements. Where components, such as indoor or outdoor coils, from different manufacturers are used, calculations and supporting data shall be furnished by the designer that demonstrates that the combined efficiency of the specified components meets the requirements herein.

**TABLE C403.2.3(1)  
MINIMUM EFFICIENCY REQUIREMENTS:  
ELECTRICALLY OPERATED UNITARY AIR CONDITIONERS AND CONDENSING UNITS**

EQUIPMENT TYPE	SIZE CATEGORY	HEATING SECTION TYPE	SUBCATEGORY OR RATING CONDITION	MINIMUM EFFICIENCY		TEST PROCEDURE <sup>a</sup>
				Before 1/1/2016	As of 1/1/2016	
Air conditioners, air cooled	< 65,000 Btu/h <sup>b</sup>	All	Split System	13.0 SEER	13.0 SEER	AHRI 210/240
			Single Package	13.0 SEER	14.0 SEER <sup>c</sup>	
Through-the-wall (air cooled)	≤ 30,000 Btu/h <sup>b</sup>	All	Split system	12.0 SEER	12.0 SEER	
			Single Package	12.0 SEER	12.0 SEER	
Small-duct high-velocity (air cooled)	< 65,000 Btu/h <sup>b</sup>	All	Split System	11.0 SEER	11.0 SEER	
Air conditioners, air cooled	≥ 65,000 Btu/h and < 135,000 Btu/h	Electric Resistance (or None)	Split System and Single Package	11.2 EER 11.4 IEER	11.2 EER 12.8 IEER	
		All other	Split System and Single Package	11.0 EER 11.2 IEER	11.0 EER 12.6 IEER	
	≥ 135,000 Btu/h and < 240,000 Btu/h	Electric Resistance (or None)	Split System and Single Package	11.0 EER 11.2 IEER	11.0 EER 12.4 IEER	
		All other	Split System and Single Package	10.8 EER 11.0 IEER	10.8 EER 12.2 IEER	
	≥ 240,000 Btu/h and < 760,000 Btu/h	Electric Resistance (or None)	Split System and Single Package	10.0 EER 10.1 IEER	10.0 EER 11.6 IEER	
		All other	Split System and Single Package	9.8 EER 9.9 IEER	9.8 EER 11.4 IEER	
	≥ 760,000 Btu/h	Electric Resistance (or None)	Split System and Single Package	9.7 EER 9.8 IEER	9.7 EER 11.2 IEER	
		All other	Split System and Single Package	9.5 EER 9.6 IEER	9.5 EER 11.0 IEER	
Air conditioners, water cooled	< 65,000 Btu/h <sup>b</sup>	All	Split System and Single Package	12.1 EER 12.3 IEER	12.1 EER 12.3 IEER	AHRI 210/240
	≥ 65,000 Btu/h and < 135,000 Btu/h	Electric Resistance (or None)	Split System and Single Package	12.1 EER 12.3 IEER	12.1 EER 13.9 IEER	AHRI 340/360
		All other	Split System and Single Package	11.9 EER 12.1 IEER	11.9 EER 13.7 IEER	
	≥ 135,000 Btu/h and < 240,000 Btu/h	Electric Resistance (or None)	Split System and Single Package	12.5 EER 12.5 IEER	12.5 EER 13.9 IEER	
		All other	Split System and Single Package	12.3 EER 12.5 IEER	12.3 EER 13.7 IEER	
	≥ 240,000 Btu/h and < 760,000 Btu/h	Electric Resistance (or None)	Split System and Single Package	12.4 EER 12.6 IEER	12.4 EER 13.6 IEER	
		All other	Split System and Single Package	12.2 EER 12.4 IEER	12.2 EER 13.4 IEER	
	≥ 760,000 Btu/h	Electric Resistance (or None)	Split System and Single Package	12.2 EER 12.4 IEER	12.2 EER 13.5 IEER	
All other		Split System and Single Package	12.0 EER 12.2 IEER	12.0 EER 13.3 IEER		

(continued)

**TABLE C403.2.3(1)—continued  
MINIMUM EFFICIENCY REQUIREMENTS:  
ELECTRICALLY OPERATED UNITARY AIR CONDITIONERS AND CONDENSING UNITS**

EQUIPMENT TYPE	SIZE CATEGORY	HEATING SECTION TYPE	SUB-CATEGORY OR RATING CONDITION	MINIMUM EFFICIENCY		TEST PROCEDURE <sup>a</sup>
				Before 1/1/2016	As of 1/1/2016	
Air conditioners, evaporatively cooled	< 65,000 Btu/h <sup>b</sup>	All	Split System and Single Package	12.1 EER 12.3 IEER	12.1 EER 12.3 IEER	AHRI 210/240           AHRI 340/360
	≥ 65,000 Btu/h and < 135,000 Btu/h	Electric Resistance (or None)	Split System and Single Package	12.1 EER 12.3 IEER	12.1 EER 12.3 IEER	
		All other	Split System and Single Package	11.9 EER 12.1 IEER	11.9 EER 12.1 IEER	
	≥ 135,000 Btu/h and < 240,000 Btu/h	Electric Resistance (or None)	Split System and Single Package	12.0 EER 12.2 IEER	12.0 EER 12.2 IEER	
		All other	Split System and Single Package	11.8 EER 12.0 IEER	11.8 EER 12.0 IEER	
	≥ 240,000 Btu/h and < 760,000 Btu/h	Electric Resistance (or None)	Split System and Single Package	11.9 EER 12.1 IEER	11.9 EER 12.1 IEER	
		All other	Split System and Single Package	11.7 EER 11.9 IEER	11.7 EER 11.9 IEER	
	≥ 760,000 Btu/h	Electric Resistance (or None)	Split System and Single Package	11.7 EER 11.9 IEER	11.7 EER 11.9 IEER	
		All other	Split System and Single Package	11.5 EER 11.7 IEER	11.5 EER 11.7 IEER	
	Condensing units, air cooled	≥ 135,000 Btu/h			10.5 EER 11.8 IEER	
Condensing units, water cooled	≥ 135,000 Btu/h			13.5 EER 14.0 IEER	13.5 EER 14.0 IEER	
Condensing units, evaporatively cooled	≥ 135,000 Btu/h			13.5 EER 14.0 IEER	13.5 EER 14.0 IEER	

For SI: 1 British thermal unit per hour = 0.2931 W.

a. Chapter 6 contains a complete specification of the referenced test procedure, including the reference year version of the test procedure.

b. Single-phase, air-cooled air conditioners less than 65,000 Btu/h are regulated by NAECA. SEER values are those set by NAECA.

c. Minimum efficiency as of January 1, 2015.

**NOTE TO RCC: 2018 TABLE C403.2.3(1) ABOVE IS BEING REPLACED WITH C403.3.2(1) BELOW**

**TABLE C403.3.2(1)**

**ELECTRICALLY OPERATED UNITARY AIR CONDITIONERS AND CONDENSING UNITS—MINIMUM EFFICIENCY REQUIREMENTS<sup>c, d</sup>**

EQUIPMENT TYPE	SIZE CATEGORY	HEADING SECTION TYPE	SUBCATEGORY OR RATING CONDITION	MINIMUM EFFICIENCY	TEST PROCEDURE <sup>a</sup>
Air conditioners, air cooled	< 65,000 Btu/h <sup>b</sup>	All	Split system, three phase and applications outside US single phase <sup>b</sup>	13.0 SEER before 1/1/2023 13.4 SEER2 after 1/1/2023	AHRI 210/240—2017 before 1/1/2023 AHRI 210/240—2023 after 1/1/2023
			Single-package, three phase and applications outside US single phase <sup>b</sup>	14.0 SEER before 1/1/2023 13.4 SEER2 after 1/1/2023	
Space constrained, air cooled	< 30,000 Btu/h <sup>b</sup>	All	Split system, three phase and applications outside US single phase <sup>b</sup>	12.0 SEER before 1/1/2023 11.7 SEER2 after 1/1/2023	AHRI 210/240—2017 before 1/1/2023 AHRI 210/240—2023 after 1/1/2023
			Single package, three phase and applications outside US single phase <sup>b</sup>	12.0 SEER before 1/1/2023 11.7 SEER2 after 1/1/2023	



<u>Small duct, high velocity, air cooled</u>	<u>&lt; 65,000 Btu/h<sup>b</sup></u>	<u>All</u>	<u>Split system, three phase and applications outside US single phase<sup>b</sup></u>	<u>12.0 SEER before 1/1/2023</u> <u>12.1 SEER<sub>2</sub> after 1/1/2023</u>	<u>AHRI 210/240—2017 before 1/1/2023</u> <u>AHRI 210/240—2023 after 1/1/2023</u>
<u>Air conditioners, air cooled</u>	<u>&gt; 65,000 Btu/h and &lt; 135,000 Btu/h</u>	<u>Electric resistance (or none)</u>	<u>Split system and single package</u>	<u>11.2 EER</u> <u>12.9 IEER before 1/1/2023</u> <u>14.8 IEER after 1/1/2023</u>	<u>AHRI 340/360</u>
		<u>All other</u>		<u>11.0 EER</u> <u>12.7 IEER before 1/1/2023</u> <u>14.6 IEER after 1/1/2023</u>	
	<u>&gt; 135,000 Btu/h and &lt; 240,000 Btu/h</u>	<u>Electric resistance (or none)</u>		<u>11.0 EER</u> <u>12.4 IEER before 1/1/2023</u> <u>14.2 IEER after 1/1/2023</u>	
		<u>All other</u>		<u>10.8 EER</u> <u>12.2 IEER before 1/1/2023</u> <u>14.0 IEER after 1/1/2023</u>	

<u>EQUIPMENT TYPE</u>	<u>SIZE CATEGORY</u>	<u>HEADING SECTION TYPE</u>	<u>SUBCATEGORY OR RATING CONDITION</u>	<u>MINIMUM EFFICIENCY</u>	<u>TEST PROCEDURE<sup>a</sup></u>
<u>Air conditioners, air cooled (continued)</u>	<u>&gt; 240,000 Btu/h and &lt; 760,000 Btu/h</u>	<u>Electric resistance (or none)</u>	<u>Split system and single package</u>	<u>10.0 EER</u> <u>11.6 IEER before 1/1/2023</u> <u>13.2 IEER after 1/1/2023</u>	<u>AHRI 340/360</u>
		<u>All other</u>		<u>9.8 EER</u> <u>11.4 IEER before 1/1/2023</u> <u>13.0 IEER after 1/1/2023</u>	
	<u>&gt; 760,000 Btu/h</u>	<u>Electric resistance (or none)</u>		<u>9.7 EER</u> <u>11.2 IEER before 1/1/2023</u> <u>12.5 IEER after 1/1/2023</u>	
		<u>All other</u>		<u>9.5 EER</u> <u>11.0 IEER before 1/1/2023</u> <u>12.3 IEER after 1/1/2023</u>	
<u>Air conditioners, water cooled</u>	<u>&lt; 65,000 Btu/h</u>	<u>All</u>	<u>Split system and single package</u>	<u>12.1 EER</u> <u>12.3 IEER</u>	<u>AHRI 210/240</u>
		<u>Electric resistance (or none)</u>		<u>12.1 EER</u> <u>13.9 IEER</u>	<u>AHRI 340/360</u>

	<u>&gt; 65,000 Btu/h</u> and <u>&lt; 135,000 Btu/h</u>	<u>All other</u>		<u>11.9 EER</u> <u>13.7 IEER</u>	
	<u>&gt; 135,000 Btu/h</u> and <u>&lt; 240,000 Btu/h</u>	<u>Electric resistance</u> <u>(or none)</u>		<u>12.5 EER</u> <u>13.9 IEER</u>	
		<u>All other</u>		<u>12.3 EER</u> <u>13.7 IEER</u>	
	<u>&gt; 240,000 Btu/h</u> and <u>&lt; 760,000 Btu/h</u>	<u>Electric resistance</u> <u>(or none)</u>		<u>12.4 EER</u> <u>13.6 IEER</u>	
		<u>All other</u>		<u>12.2 EER</u> <u>13.4 IEER</u>	
	<u>&gt; 760,000 Btu/h</u>	<u>Electric resistance</u> <u>(or none)</u>		<u>12.2 EER</u> <u>13.5 IEER</u>	
		<u>All other</u>		<u>12.0 EER</u> <u>13.3 IEER</u>	

<u>EQUIPMENT TYPE</u>	<u>SIZE CATEGORY</u>	<u>HEADING SECTION TYPE</u>	<u>SUBCATEGORY OR RATING CONDITION</u>	<u>MINIMUM EFFICIENCY</u>	<u>TEST PROCEDURE<sup>a</sup></u>
<u>Air conditioners, evaporatively cooled</u>	<u>&lt; 65,000 Btu/h<sup>b</sup></u>	<u>All</u>	<u>Split system and single package</u>	<u>12.1 EER</u> <u>12.3 IEER</u>	<u>AHRI 210/240</u>
	<u>&gt; 65,000 Btu/h</u> and <u>&lt; 135,000 Btu/h</u>	<u>Electric resistance</u> <u>(or none)</u>		<u>12.1 EER</u> <u>12.3 IEER</u>	<u>AHRI 340/360</u>
		<u>All other</u>		<u>11.9 EER</u> <u>12.1 IEER</u>	
	<u>&gt; 135,000 Btu/h</u> and <u>&lt; 240,000 Btu/h</u>	<u>Electric resistance</u> <u>(or none)</u>		<u>12.0 EER</u> <u>12.2 IEER</u>	
		<u>All other</u>		<u>11.8 EER</u> <u>12.0 IEER</u>	
	<u>&gt; 240,000 Btu/h</u> and <u>&lt; 760,000 Btu/h</u>	<u>Electric resistance</u> <u>(or none)</u>		<u>11.9 EER</u> <u>12.1 IEER</u>	
		<u>All other</u>		<u>11.7 EER</u> <u>11.9 IEER</u>	
	<u>&gt; 760,000 Btu/h</u>	<u>Electric resistance</u> <u>(or none)</u>		<u>11.7 EER</u> <u>11.9 IEER</u>	
	<u>All other</u>	<u>11.5 EER</u> <u>11.7 IEER</u>			
<u>Condensing units, air cooled</u>	<u>&gt; 135,000 Btu/h</u>	<u>=</u>	<u>=</u>	<u>10.5 EER</u> <u>11.8 IEER</u>	<u>AHRI 365</u>
<u>Condensing units, water cooled</u>	<u>&gt; 135,000 Btu/h</u>	<u>=</u>	<u>=</u>	<u>13.5 EER</u> <u>14.0 IEER</u>	<u>AHRI 365</u>
<u>Condensing units, evaporatively cooled</u>	<u>&gt; 135,000 Btu/h</u>	<u>=</u>	<u>=</u>	<u>13.5 EER</u> <u>14.0 IEER</u>	<u>AHRI 365</u>

For SI: 1 British thermal unit per hour = 0.2931 W.

- a. Chapter 6 contains a complete specification of the referenced standards, which include test procedures, including the reference year version of the test procedure.
- b. Single-phase, US air-cooled air conditioners less than 65,000 Btu/h are regulated as consumer products by the US Department of Energy Code of Federal Regulations DOE 10 CFR 430. SEER and SEER2 values for single-phase products are set by the US Department of Energy.
- c. DOE 10 CFR 430 Subpart B Appendix M1 includes the test procedure updates effective 1/1/2023 that will be incorporated in AHRI 210/240—2023.
- d. This table is a replica of ASHRAE 90.1 Table 6.8.1-1 Electrically Operated Unitary Air Conditioners and Condensing Units—Minimum Efficiency Requirements.

**TABLE C403.2.3(2)  
MINIMUM EFFICIENCY REQUIREMENTS:  
ELECTRICALLY OPERATED UNITARY AND APPLIED HEAT PUMPS**

EQUIPMENT TYPE	SIZE CATEGORY	HEATING SECTION TYPE	SUBCATEGORY OR RATING CONDITION	MINIMUM EFFICIENCY		TEST PROCEDURE <sup>a</sup>	
				Before 1/1/2016	As of 1/1/2016		
Air cooled (cooling mode)	< 65,000 Btu/h <sup>b</sup>	All	Split System	13.0 SEER <sup>c</sup>	14.0 SEER	AHRI 210/240	
			Single Package	13.0 SEER <sup>c</sup>	14.0 SEER <sup>c</sup>		
Through-the-wall, air cooled	≤ 30,000 Btu/h <sup>b</sup>	All	Split System	12.0 SEER	12.0 SEER		
			Single Package	12.0 SEER	12.0 SEER		
Single-duct high-velocity air cooled	< 65,000 Btu/h <sup>b</sup>	All	Split System	11.0 SEER	11.0 SEER		
Air cooled (cooling mode)	≥ 65,000 Btu/h and < 135,000 Btu/h	Electric Resistance (or None)	Split System and Single Package	11.0 EER	11.0 EER		AHRI 340/360
		All other	Split System and Single Package	11.2 IEER	12.0 IEER		
	≥ 135,000 Btu/h and < 240,000 Btu/h	Electric Resistance (or None)	Split System and Single Package	10.8 EER	10.8 EER		
		All other	Split System and Single Package	11.0 IEER	11.8 IEER		
	≥ 240,000 Btu/h	Electric Resistance (or None)	Split System and Single Package	10.6 EER	10.6 EER		
		All other	Split System and Single Package	10.7 IEER	11.6 IEER		
Water to Air: Water Loop (cooling mode)	< 17,000 Btu/h	All	86°F entering water	9.5 EER	9.5 EER	ISO 13256-1	
	≥ 17,000 Btu/h and < 65,000 Btu/h	All	86°F entering water	9.6 IEER	10.6 IEER		
	≥ 65,000 Btu/h and < 135,000 Btu/h	All	86°F entering water	9.3 EER	9.3 EER		
Water to Air: Ground Water (cooling mode)	< 135,000 Btu/h	All	59°F entering water	9.4 IEER	9.4 IEER	ISO 13256-1	
Brine to Air: Ground Loop (cooling mode)	< 135,000 Btu/h	All	77°F entering water	18.0 EER	18.0 EER	ISO 13256-1	
Water to Water: Water Loop (cooling mode)	< 135,000 Btu/h	All	86°F entering water	14.1 EER	14.1 EER	ISO 13256-1	
Water to Water: Ground Water (cooling mode)	< 135,000 Btu/h	All	59°F entering water	10.6 EER	10.6 EER	ISO 13256-2	
Brine to Water: Ground Loop (cooling mode)	< 135,000 Btu/h	All	77°F entering fluid	16.3 EER	16.3 EER		
				12.1 EER	12.1 EER		

*(continued)*

**TABLE C403.2.3(2)—continued  
MINIMUM EFFICIENCY REQUIREMENTS:  
ELECTRICALLY OPERATED UNITARY AND APPLIED HEAT PUMPS**

EQUIPMENT TYPE	SIZE CATEGORY	HEATING SECTION TYPE	SUBCATEGORY OR RATING CONDITION	MINIMUM EFFICIENCY		TEST PROCEDURE <sup>a</sup>
				Before 1/1/2016	As of 1/1/2016	
Air cooled (heating mode)	< 65,000 Btu/h <sup>b</sup>	—	Split System	7.7 HSPF <sup>c</sup>	8.2 HSPF <sup>c</sup>	AHRI 210/240
		—	Single Package	7.7 HSPF <sup>c</sup>	8.0 HSPF <sup>c</sup>	
Through-the-wall, (air cooled, heating mode)	≤ 30,000 Btu/h <sup>b</sup> (cooling capacity)	—	Split System	7.4 HSPF	7.4 HSPF	
		—	Single Package	7.4 HSPF	7.4 HSPF	
Small-duct high velocity (air cooled, heating mode)	< 65,000 Btu/h <sup>b</sup>	—	Split System	6.8 HSPF	6.8 HSPF	
Air cooled (heating mode)	≥ 65,000 Btu/h and < 135,000 Btu/h (cooling capacity)	—	47°F db/47°F wb outdoor air	3.3 COP	3.3 COP	AHRI 340/360
		—	17°F db/15°F wb outdoor air	2.25 COP	2.25 COP	
	≥ 135,000 Btu/h (cooling capacity)	—	47°F db/43°F wb outdoor air	3.2 COP	3.2 COP	
		—	17°F db/15°F wb outdoor air	2.05 COP	2.05 COP	
Water to Air: Water Loop (heating mode)	< 135,000 Btu/h (cooling capacity)	—	68°F entering water	4.3 COP	4.3 COP	ISO 13256-1
Water to Air: Ground Water (heating mode)	< 135,000 Btu/h (cooling capacity)	—	50°F entering water	3.7 COP	3.7 COP	
Brine to Air: Ground Loop (heating mode)	< 135,000 Btu/h (cooling capacity)	—	32°F entering fluid	3.2 COP	3.2 COP	
Water to Water: Water Loop (heating mode)	< 135,000 Btu/h (cooling capacity)	—	68°F entering water	3.7 COP	3.7 COP	ISO 13256-2
Water to Water: Ground Water (heating mode)	< 135,000 Btu/h (cooling capacity)	—	50°F entering water	3.1 COP	3.1 COP	
Brine to Water: Ground Loop (heating mode)	< 135,000 Btu/h (cooling capacity)	—	32°F entering fluid	2.5 COP	2.5 COP	

For SE: 1 British thermal unit per hour = 0.2931 W, °C = [(°F) - 32]/1.8.

a. Chapter 6 contains a complete specification of the referenced test procedure, including the reference year version of the test procedure.

b. Single-phase, air-cooled air conditioners less than 65,000 Btu/h are regulated by NAECA. SEER values are those set by NAECA.

c. Minimum efficiency as of January 1, 2015.

**NOTE TO RRC – 2018 TABLE C403.2.3(2) ABOVE IS REPLACED WITH TABLE C403.3.2(2) BELOW!**

**TABLE C403.3.2(2)**

**ELECTRICALLY OPERATED AIR-COOLED UNITARY HEAT PUMPS—MINIMUM EFFICIENCY REQUIREMENTS<sup>c, d</sup>**

EQUIPMENT TYPE	SIZE CATEGORY	HEATING SECTION TYPE	SUBCATEGORY OR RATING CONDITION	MINIMUM EFFICIENCY	TEST PROCEDURE <sup>a</sup>
Air cooled (cooling mode)	≤ 66,000 Btu/h	All	Split system, three phase and applications outside US single phase <sup>b</sup>	14.0 SEER before 1/1/2023 14.3 SEER2 after 1/1/2023	AHRI 210/240—2017 before 1/1/2023 AHRI 210/240—2023 after 1/1/2023
			Single package, three phase and applications outside US single phase <sup>b</sup>	14.0 SEER before 1/1/2023 13.4 SEER2 after 1/1/2023	
Space constrained, air cooled (cooling mode)	≤ 30,000 Btu/h	All	Split system, three phase and applications outside US single phase <sup>b</sup>	12.0 SEER before 1/1/2023 11.7 SEER2 after 1/1/2023	AHRI 210/240—2017 before 1/1/2023 AHRI 210/240—2023 after 1/1/2023

			<u>Single package, three phase and applications outside US single phase<sup>b</sup></u>	<u>12.0 SEER before 1/1/2023</u> <u>11.7 SEER2 after 1/1/2023</u>	
<u>Single duct, high velocity, air cooled (cooling mode)</u>	<u>&lt; 65,000</u>	<u>All</u>	<u>Split system, three phase and applications outside US single phase<sup>b</sup></u>	<u>12.0 SEER before 1/1/2023</u> <u>12.0 SEER2 after 1/1/2023</u>	<u>AHRI 210/240—2017 before 1/1/2023</u> <u>AHRI 210/240—2023 after 1/1/2023</u>
<u>Air cooled (cooling mode)</u>	<u>&gt; 65,000 Btu/h and &lt; 135,000 Btu/h</u>	<u>Electric resistance (or none)</u>	<u>Split system and single package</u>	<u>11.0 EER 12.2 IEER before 1/1/2023</u> <u>14.1 IEER after 1/1/2023</u>	<u>AHRI 340/360</u>
		<u>All other</u>		<u>10.8 EER 12.0 IEER before 1/1/2023</u> <u>13.9 IEER after 1/1/2023</u>	
	<u>&gt; 135,000 Btu/h and &lt; 240,000 Btu/h</u>	<u>Electric resistance (or none)</u>		<u>10.6 EER 11.6 IEER before 1/1/2023</u> <u>13.5 IEER after 1/1/2023</u>	
		<u>All other</u>		<u>10.4 EER 11.4 IEER before 1/1/2023</u> <u>13.3 IEER after 1/1/2023</u>	
	<u>&gt; 240,000 Btu/h</u>	<u>Electric resistance (or none)</u>		<u>9.5 EER 10.6 IEER before 1/1/2023</u> <u>12.5 IEER after 1/1/2023</u>	
		<u>All other</u>		<u>9.3 EER 10.4 IEER before 1/1/2023</u> <u>12.3 IEER after 1/1/2023</u>	
<u>Air cooled (heating mode)</u>	<u>&lt; 65,000 Btu/h</u>	<u>All</u>	<u>Split system, three phase and applications outside US single phase<sup>b</sup></u>	<u>8.2 HSPF before 1/1/2023</u> <u>7.5 HSPF2 after 1/1/2023</u>	<u>AHRI 210/240—2017 before 1/1/2023</u> <u>AHRI 210/240—2023 after 1/1/2023</u>
			<u>Single package, three phase and applications outside US single phase<sup>b</sup></u>	<u>8.0 HSPF before 1/1/2023</u> <u>6.7 HSPF2 after 1/1/2023</u>	

<u>EQUIPMENT TYPE</u>	<u>SIZE CATEGORY</u>	<u>HEADING SECTION TYPE</u>	<u>SUBCATEGORY OR RATING CONDITION</u>	<u>MINIMUM EFFICIENCY</u>	<u>TEST PROCEDURE<sup>a</sup></u>
<u>Space constrained, air cooled (heating mode)</u>	<u>&lt; 30,000 Btu/h</u>	<u>All</u>	<u>Split system, three phase and applications outside US single phase<sup>b</sup></u>	<u>7.4 HSPF before 1/1/2023</u> <u>6.3 HSPF2 after 1/1/2023</u>	<u>AHRI 210/240—2017 before 1/1/2023</u> <u>AHRI 210/240—2023 after 1/1/2023</u>

			Single package, three phase and applications outside US single phase <sup>b</sup>	<u>7.4 HSPF</u> before 1/1/2023 <u>6.3 HSPF2</u> after 1/1/2023	
<u>Small duct, high velocity, air cooled (heating mode)</u>	<u>&lt; 65,000 Btu/h</u>	<u>All</u>	<u>Split system, three phase and applications outside US single phase<sup>b</sup></u>	<u>7.2 HSPF</u> before 1/1/2023 <u>6.1 HSPF2</u> after 1/1/2023	<u>AHRI 210/240—2017</u> before 1/1/2023 <u>AHRI 210/240—2023</u> after 1/1/2023
<u>Air cooled (heating mode)</u>	<u>≥ 65,000 Btu/h and &lt; 135,000 Btu/h (cooling capacity)</u>	<u>All</u>	<u>47°F db/43°F wb outdoor air</u>	<u>3.30 COP<sub>H</sub> before 1/1/2023</u> <u>3.40 COP<sub>H</sub> after 1/1/2023</u>	<u>AHRI 340/360</u>
			<u>17°F db/15°F wb outdoor air</u>	<u>2.25 COP<sub>H</sub></u>	
	<u>≥ 135,000 Btu/h and &lt; 240,000 Btu/h (cooling capacity)</u>		<u>47°F db/43°F wb outdoor air</u>	<u>3.20 COP<sub>H</sub> before 1/1/2023</u> <u>3.30 SOP<sub>H</sub> after 1/1/2023</u>	
			<u>17°F db/15°F wb outdoor air</u>	<u>2.05 COP<sub>H</sub></u>	
	<u>≥ 240,000 Btu/h (cooling capacity)</u>		<u>47°F db/43°F wb outdoor air</u>	<u>3.20 COP<sub>H</sub></u>	
			<u>17°F db/15°F wb outdoor air</u>	<u>2.05 COP<sub>H</sub></u>	

For SI: 1 British thermal unit per hour = 0.2931 W, °C = [(°F) – 32]/1.8, wb = wet bulb, db = dry bulb.

- Chapter 6 contains a complete specification of the referenced standards, which include test procedures, including the reference year version of the test procedure.
- Single-phase, US air-cooled heat pumps less than 65,000 Btu/h are regulated as consumer products by the US Department of Energy Code of Federal Regulations DOE 10 CFR 430. SEER, SEER2 and HSPF values for single-phase products are set by the US Department of Energy.
- DOE 10 CFR 430 Subpart B Appendix M1 includes the test procedure updates effective 1/1/2023 that will be incorporated in AHRI 210/240—2023.
- This table is a replica of ASHRAE 90.1 Table 6.8.1-2 Electrically Operated Air-Cooled Unitary Heat Pumps—Minimum Efficiency Requirements.

**TABLE C403.2.3(3)**  
**MINIMUM EFFICIENCY REQUIREMENTS:**  
**ELECTRICALLY OPERATED PACKAGED TERMINAL AIR CONDITIONERS,**  
**PACKAGED TERMINAL HEAT PUMPS, SINGLE-PACKAGE VERTICAL AIR CONDITIONERS,**  
**SINGLE VERTICAL HEAT PUMPS, ROOM AIR CONDITIONERS AND ROOM AIR-CONDITIONER HEAT PUMPS**

EQUIPMENT TYPE	SIZE CATEGORY (INPUT)	SUBCATEGORY OR RATING CONDITION	MINIMUM EFFICIENCY	TEST PROCEDURE <sup>a</sup>
PTAC (cooling mode) new construction	All Capacities	95°F db outdoor air	14.0 - (0.300 × Cap/1000) EER <sup>c</sup>	AHRI 310/380
PTAC (cooling mode) replacements <sup>b</sup>	All Capacities	95°F db outdoor air	10.9 - (0.213 × Cap/1000) EER	
PTHP (cooling mode) new construction	All Capacities	95°F db outdoor air	14.0 - (0.300 × Cap/1000) EER	
PTHP (cooling mode) replacements <sup>b</sup>	All Capacities	95°F db outdoor air	10.8 - (0.213 × Cap/1000) EER	
PTHP (heating mode) new construction	All Capacities	—	3.2 - (0.026 × Cap/1000) COP	
PTHP (heating mode) replacements <sup>b</sup>	All Capacities	—	2.9 - (0.026 × Cap/1000) COP	
SPVAC (cooling mode)	< 65,000 Btu/h	95°F db/ 75°F wb outdoor air	9.0 EER	AHRI 390
	≥ 65,000 Btu/h and < 135,000 Btu/h	95°F db/ 75°F wb outdoor air	8.9 EER	
	≥ 135,000 Btu/h and < 240,000 Btu/h	95°F db/ 75°F wb outdoor air	8.6 EER	
SPVHP (cooling mode)	< 65,000 Btu/h	95°F db/ 75°F wb outdoor air	9.0 EER	
	≥ 65,000 Btu/h and < 135,000 Btu/h	95°F db/ 75°F wb outdoor air	8.9 EER	
	≥ 135,000 Btu/h and < 240,000 Btu/h	95°F db/ 75°F wb outdoor air	8.6 EER	
SPVHP (heating mode)	< 65,000 Btu/h	47°F db/ 43°F wb outdoor air	3.0 COP	AHRI 390
	≥ 65,000 Btu/h and < 135,000 Btu/h	47°F db/ 43°F wb outdoor air	3.0 COP	
	≥ 135,000 Btu/h and < 240,000 Btu/h	47°F db/ 75°F wb outdoor air	2.9 COP	
Room air conditioners, with louvered sides	< 6,000 Btu/h	—	9.7 SEER	ANSI/AHAM RAC-1
	≥ 6,000 Btu/h and < 8,000 Btu/h	—	9.7 EER	
	≥ 8,000 Btu/h and < 14,000 Btu/h	—	9.8 EER	
	≥ 14,000 Btu/h and < 20,000 Btu/h	—	9.7 SEER	
	≥ 20,000 Btu/h	—	8.5 EER	
Room air conditioners without louvered sides	< 8,000 Btu/h	—	9.0 EER	
	≥ 8,000 Btu/h and < 20,000 Btu/h	—	8.5 EER	
	≥ 20,000 Btu/h	—	8.5 EER	
Room air-conditioner heat pumps with louvered sides	< 20,000 Btu/h	—	9.0 EER	
	≥ 20,000 Btu/h	—	8.5 EER	
Room air-conditioner heat pumps without louvered sides	< 14,000 Btu/h	—	8.5 EER	
	≥ 14,000 Btu/h	—	8.0 EER	

(continued)

**TABLE C403.2.3(3)—continued**  
**MINIMUM EFFICIENCY REQUIREMENTS:**  
**ELECTRICALLY OPERATED PACKAGED TERMINAL AIR CONDITIONERS,**  
**PACKAGED TERMINAL HEAT PUMPS, SINGLE-PACKAGE VERTICAL AIR CONDITIONERS,**  
**SINGLE VERTICAL HEAT PUMPS, ROOM AIR CONDITIONERS AND ROOM AIR-CONDITIONER HEAT PUMPS**

EQUIPMENT TYPE	SIZE CATEGORY (INPUT)	SUBCATEGORY OR RATING CONDITION	MINIMUM EFFICIENCY	TEST PROCEDURE <sup>a</sup>
Room air conditioner casement only	All capacities	—	8.7 EER	ANSI/ AHAM RAC-1
Room air conditioner casement-slider	All capacities	—	9.5 EER	

For SI: 1 British thermal unit per hour = 0.2931 W, °C = [(°F) - 32]/1.8, wb = wet bulb, db = dry bulb.

"Cap" = The rated cooling capacity of the project in Btu/h. Where the unit's capacity is less than 7000 Btu/h, use 7000 Btu/h in the calculation. Where the unit's capacity is greater than 15,000 Btu/h, use 15,000 Btu/h in the calculations.

a. Chapter 6 contains a complete specification of the referenced test procedure, including the referenced year version of the test procedure.

b. Replacement unit shall be factory labeled as follows: "MANUFACTURED FOR REPLACEMENT APPLICATIONS ONLY; NOT TO BE INSTALLED IN NEW CONSTRUCTION PROJECTS." Replacement efficiencies apply only to units with existing sleeves less than 16 inches (406 mm) in height and less than 12 inches (1067 mm) in width.

c. Before January 1, 2015 the minimum efficiency shall be 13.8 - (0.300 × Cap/1000) EER.

Note to RRC, Table C403.2.3(3) above is replaced with TABLE C403.3.2(4) below

**TABLE C403.3.2(4)**

**ELECTRICALLY OPERATED PACKAGED TERMINAL AIR CONDITIONERS, PACKAGED TERMINAL HEAT PUMPS,**  
**SINGLE-PACKAGE VERTICAL AIR CONDITIONERS, SINGLE-PACKAGE VERTICAL HEAT PUMPS, ROOM AIR CONDITIONERS**  
**AND ROOM AIR-CONDITIONER HEAT PUMPS—MINIMUM EFFICIENCY REQUIREMENTS<sup>a</sup>**

EQUIPMENT TYPE	SIZE CATEGORY (INPUT)	SUBCATEGORY OR RATING CONDITION	MINIMUM EFFICIENCY <sup>d</sup>	TEST PROCEDURE <sup>a</sup>
PTAC (cooling mode) standard size	< 7,000 Btu/h	95°F db/75°F wb outdoor air <sup>c</sup>	11.9 EER	AHRI 310/380
	≥ 7,000 Btu/h and ≤ 15,000 Btu/h		$14.0 - (0.300 \times \text{Cap}/1,000)$ EER <sup>d</sup>	
	> 15,000 Btu/h		9.5 EER	
PTAC (cooling mode) nonstandard size <sup>a</sup>	< 7,000 Btu/h	95°F db/75°F wb outdoor air <sup>c</sup>	9.4 EER	AHRI 310/380
	≥ 7,000 Btu/h and ≤ 15,000 Btu/h		$10.9 - (0.213 \times \text{Cap}/1,000)$ EER <sup>d</sup>	
	> 15,000 Btu/h		7.7 EER	
PTHP (cooling mode) standard size	< 7,000 Btu/h	95°F db/75°F wb outdoor air <sup>c</sup>	11.9 EER	AHRI 310/380
	≥ 7,000 Btu/h and ≤ 15,000 Btu/h		$14.0 - (0.300 \times \text{Cap}/1,000)$ EER <sup>d</sup>	
	> 15,000 Btu/h		9.5 EER	
PTHP (cooling mode) nonstandard size <sup>b</sup>	< 7,000 Btu/h	95°F db/75°F wb outdoor air <sup>c</sup>	9.3 EER	AHRI 310/380
	≥ 7,000 Btu/h and ≤ 15,000 Btu/h		$10.8 - (0.213 \times \text{Cap}/1,000)$ EER <sup>d</sup>	
	> 15,000 Btu/h		7.6 EER	
PTHP (heating mode) standard size	< 7,000 Btu/h	47°F db/43°F wb outdoor air	3.3 COP <sub>H</sub>	AHRI 310/380
	≥ 7,000 Btu/h and ≤ 15,000 Btu/h		$3.7 - (0.052 \times \text{Cap}/1,000)$ COP <sub>H</sub> <sup>d</sup>	
	> 15,000 Btu/h		2.90 COP <sub>H</sub>	
PTHP (heating mode) nonstandard size <sup>b</sup>	< 7,000 Btu/h	47°F db/43°F wb outdoor air	2.7 COP <sub>H</sub>	AHRI 310/380
	≥ 7,000 Btu/h and ≤ 15,000 Btu/h		$2.9 - (0.026 \times \text{Cap}/1000)$ COP <sub>H</sub> <sup>d</sup>	
	> 15,000 Btu/h		2.5 COP <sub>H</sub>	
	< 65,000 Btu/h	95°F db/75°F wb	11.0 EER	AHRI 390



<u>SPVAC (cooling mode) single and three phase</u>	<u>&gt; 65,000 Btu/h and ≤ 135,000 Btu/h</u>	<u>outdoor air<sup>c</sup></u>	<u>10.0 EER</u>	
	<u>&gt; 135,000 Btu/h and ≤ 240,000 Btu/h</u>		<u>10.0 EER</u>	
<u>SPVHP (cooling mode)</u>	<u>≤ 65,000 Btu/h</u>	<u>95°F db/75°F wb outdoor air<sup>c</sup></u>	<u>11.0 EER</u>	<u>AHRI 390</u>
	<u>&gt; 65,000 Btu/h and ≤ 135,000 Btu/h</u>		<u>10.0 EER</u>	
	<u>&gt; 135,000 Btu/h and ≤ 240,000 Btu/h</u>		<u>10.1 EER</u>	
<u>SPVHP (heating mode)</u>	<u>≤ 65,000 Btu/h</u>	<u>47°F db/43°F wb outdoor air</u>	<u>3.3 COP<sub>H</sub></u>	<u>AHRI 390</u>
	<u>&gt; 65,000 Btu/h and ≤ 135,000 Btu/h</u>		<u>3.0 COP<sub>H</sub></u>	
	<u>&gt; 135,000 Btu/h and ≤ 240,000 Btu/h</u>		<u>3.0 COP<sub>H</sub></u>	

<u>EQUIPMENT TYPE</u>	<u>SIZE CATEGORY (INPUT)</u>	<u>SUBCATEGORY OR RATING CONDITION</u>	<u>MINIMUM EFFICIENCY<sup>d</sup></u>	<u>TEST PROCEDURE<sup>a</sup></u>
<u>Room air conditioners without reverse cycle with louvered sides for applications outside US</u>	<u>&lt; 6,000 Btu/h</u>	<u>=</u>	<u>11.0 CEER</u>	<u>ANSI/AHAM RAC-1</u>
	<u>&gt; 6,000 Btu/h and &lt; 8,000 Btu/h</u>	<u>=</u>	<u>11.0 CEER</u>	
	<u>&gt; 8,000 Btu/h and &lt; 14,000 Btu/h</u>	<u>=</u>	<u>10.9 CEER</u>	
	<u>&gt; 14,000 Btu/h and &lt; 20,000 Btu/h</u>	<u>=</u>	<u>10.7 CEER</u>	
	<u>&gt; 20,000 Btu/h and &lt; 28,000 Btu/h</u>	<u>=</u>	<u>9.4 CEER</u>	
	<u>≥ 28,000 Btu/h</u>	<u>=</u>	<u>9.0 CEER</u>	
<u>Room air conditioners without louvered sides</u>	<u>&lt; 6,000 Btu/h</u>	<u>=</u>	<u>10.0 CEER</u>	<u>ANSI/AHAM RAC-1</u>
	<u>&gt; 6,000 Btu/h and &lt; 8,000 Btu/h</u>	<u>=</u>	<u>10.0 CEER</u>	
	<u>≥ 8,000 Btu/h and &lt; 11,000 Btu/h</u>	<u>=</u>	<u>9.6 CEER</u>	
	<u>≥ 11,000 Btu/h and &lt; 14,000 Btu/h</u>	<u>=</u>	<u>9.5 CEER</u>	
	<u>≥ 14,000 Btu/h and &lt; 20,000 Btu/h</u>	<u>=</u>	<u>9.3 CEER</u>	
	<u>≥ 20,000 Btu/h</u>	<u>=</u>	<u>9.4 CEER</u>	
<u>Room air conditioners with reverse cycle, with louvered sides for applications outside US</u>	<u>&lt; 20,000 Btu/h</u>	<u>=</u>	<u>9.8 CEER</u>	<u>ANSI/AHAM RAC-1</u>
	<u>≥ 20,000 Btu/h</u>	<u>=</u>	<u>9.3 CEER</u>	
	<u>&lt; 14,000 Btu/h</u>	<u>=</u>	<u>9.3 CEER</u>	<u>ANSI/AHAM RAC-1</u>

<u>Room air conditioners with reverse cycle without louvered sides for applications outside US</u>	<u>≥ 14,000 Btu/h</u>	<u>=</u>	<u>8.7 CEER</u>	
<u>Room air conditioners, casement only for applications outside US</u>	<u>All</u>	<u>=</u>	<u>9.5 CEER</u>	<u>ANSI/AHAM RAC-1</u>
<u>Room air conditioners, casement slider for applications outside US</u>	<u>All</u>	<u>=</u>	<u>10.4 CEER</u>	<u>ANSI/AHAM RAC-1</u>

For SI: 1 British thermal unit per hour = 0.2931 W, °C = [(°F) – 32]/1.8, wb = wet bulb, db = dry bulb.

“Cap” = The rated cooling capacity of the project in Btu/h. Where the unit’s capacity is less than 7,000 Btu/h, use 7,000 Btu/h in the calculation. Where the unit’s capacity is greater than 15,000 Btu/h, use 15,000 Btu/h in the calculations.

- Chapter 6 contains a complete specification of the referenced standards, which include test procedures, including the reference year version of the test procedure.
- Nonstandard size units must be factory labeled as follows: “MANUFACTURED FOR NONSTANDARD SIZE APPLICATIONS ONLY; NOT TO BE INSTALLED IN NEW STANDARD PROJECTS.” Nonstandard size efficiencies apply only to units being installed in existing sleeves having an external wall opening of less than 16 inches (406 mm) high or less than 42 inches (1067 mm) wide and having a cross-sectional area less than 670 square inches (0.43 m<sup>2</sup>).
- The cooling-mode wet bulb temperature requirement only applies for units that reject condensate to the condenser coil.
- “Cap” in EER and COPH equations for PTACs and PTHPs means cooling capacity in Btu/h at 95°F outdoor dry-bulb temperature.
- This table is a replica of ASHRAE 90.1 Table 6.8.1-4 Electrically Operated Packaged Terminal Air Conditioners, Packaged Terminal Heat Pumps, Single-Package Vertical Air Conditioners, Single-Package Vertical Heat Pumps, Room Air Conditioners, and Room Air-Conditioner Heat Pumps—Minimum Efficiency Requirements.

**TABLE 403.2.3(4)  
WARM-AIR FURNACES AND COMBINATION WARM-AIR FURNACES/AIR-CONDITIONING UNITS,  
WARM-AIR DUCT FURNACES AND UNIT HEATERS, MINIMUM EFFICIENCY REQUIREMENTS**

EQUIPMENT TYPE	SIZE CATEGORY (INPUT)	SUBCATEGORY OR RATING CONDITION	MINIMUM EFFICIENCY <sup>a,*</sup>	TEST PROCEDURE <sup>a</sup>
Warm-air furnaces, gas fired	< 225,000 Btu/h	—	78% AFUE or 80% E <sub>t</sub> <sup>c</sup>	DOE 10 CFR Part 430 or ANSI Z21.47
	≥ 225,000 Btu/h	Maximum capacity <sup>c</sup>	80% E <sub>t</sub> <sup>f</sup>	ANSI Z21.47
Warm-air furnaces, oil fired	< 225,000 Btu/h	—	78% AFUE or 80% E <sub>t</sub> <sup>c</sup>	DOE 10 CFR Part 430 or UL 727
	≥ 225,000 Btu/h	Maximum capacity <sup>b</sup>	81% E <sub>t</sub> <sup>f</sup>	UL 727
Warm-air duct furnaces, gas fired	All capacities	Maximum capacity <sup>b</sup>	80% E <sub>c</sub>	ANSI Z83.8
Warm-air unit heaters, gas fired	All capacities	Maximum capacity <sup>b</sup>	80% E <sub>c</sub>	ANSI Z83.8
Warm-air unit heaters, oil fired	All capacities	Maximum capacity <sup>b</sup>	80% E <sub>c</sub>	UL 731

For SI: 1 British thermal unit per hour = 0.2931 W.

- Chapter 6 contains a complete specification of the referenced test procedure, including the referenced year version of the test procedure.
- Minimum and maximum ratings as provided for and allowed by the unit’s controls.
- Combination units not covered by the National Appliance Energy Conservation Act of 1987 (NAECA) (3-phase power or cooling capacity greater than or equal to 65,000 Btu/h [19 kW]) shall comply with either rating.
- E<sub>t</sub> = Thermal efficiency. See test procedure for detailed discussion.
- E<sub>c</sub> = Combustion efficiency (100% less flue losses). See test procedure for detailed discussion.
- E<sub>c</sub> = Combustion efficiency. Units shall also include an IID, have jackets not exceeding 0.75 percent of the input rating, and have either power venting or a flue damper. A vent damper is an acceptable alternative to a flue damper for those furnaces where combustion air is drawn from the conditioned space.
- E<sub>t</sub> = Thermal efficiency. Units shall also include an IID, have jacket losses not exceeding 0.75 percent of the input rating, and have either power venting or a flue damper. A vent damper is an acceptable alternative to a flue damper for those furnaces where combustion air is drawn from the conditioned space.

**Note to RRC, Table C403.2.3(4) above is replaced with TABLE C403.3.2(5) below**

**TABLE C403.3.2(5)**

**WARM-AIR FURNACES AND COMBINATION WARM-AIR FURNACES/AIR-CONDITIONING UNITS,  
WARM-AIR DUCT FURNACES AND UNIT HEATERS—MINIMUM EFFICIENCY REQUIREMENTS<sup>a</sup>**

EQUIPMENT TYPE	SIZE CATEGORY (INPUT)	SUBCATEGORY OR RATING CONDITION	MINIMUM EFFICIENCY	TEST PROCEDURE <sup>a</sup>
----------------	-----------------------	---------------------------------	--------------------	-----------------------------

<u>Warm-air furnace, gas fired for application outside the US</u>	<u>&lt; 225,000 Btu/h</u>	<u>Maximum capacity<sup>c</sup></u>	<u>80% AFUE (nonweatherized) or 81% AFUE (weatherized) or 80% <math>E_t^{b,d}</math></u>	<u>DOE 10 CFR 430 Appendix N or Section 2.39, Thermal Efficiency, ANSI Z21.47</u>
<u>Warm-air furnace, gas fired</u>	<u>&lt; 225,000 Btu/h</u>	<u>Maximum capacity<sup>c</sup></u>	<u>80% <math>E_t^{b,d}</math> before 1/1/2023 81% <math>E_t^d</math> after 1/1/2023</u>	<u>Section 2.39, Thermal Efficiency, ANSI Z21.47</u>
<u>Warm-air furnace, oil fired for application outside the US</u>	<u>&lt; 225,000 Btu/h</u>	<u>Maximum capacity<sup>c</sup></u>	<u>83% AFUE (nonweatherized) or 78% AFUE (weatherized) or 80% <math>E_t^{b,d}</math></u>	<u>DOE 10 CFR 430 Appendix N or Section 42, Combustion, UL 727</u>
<u>Warm-air furnace, oil fired</u>	<u>&lt; 225,000 Btu/h</u>	<u>Maximum capacity<sup>c</sup></u>	<u>80% <math>E_t</math> before 1/1/2023 82% <math>E_t^d</math> after 1/1/2023</u>	<u>Section 42, Combustion, UL 727</u>
<u>Electric furnaces for applications outside the US</u>	<u>&lt; 225,000 Btu/h</u>	<u>All</u>	<u>96% AFUE</u>	<u>DOE 10 CFR 430 Appendix N</u>
<u>Warm-air duct furnaces, gas fired</u>	<u>All capacities</u>	<u>Maximum capacity<sup>c</sup></u>	<u>80% <math>E_c^e</math></u>	<u>Section 2.10, Efficiency, ANSI Z83.8</u>
<u>Warm-air unit heaters, gas fired</u>	<u>All capacities</u>	<u>Maximum capacity<sup>c</sup></u>	<u>80% <math>E_c^{e,f}</math></u>	<u>Section 2.10, Efficiency, ANSI Z83.8</u>
<u>Warm-air unit heaters, oil fired</u>	<u>All capacities</u>	<u>Maximum capacity<sup>c</sup></u>	<u>80% <math>E_c^{e,f}</math></u>	<u>Section 40, Combustion, UL 731</u>

For SI: 1 British thermal unit per hour = 0.2931 W.

- Chapter 6 contains a complete specification of the referenced standards, which include test procedures, including the reference year version of the test procedure.
- Combination units (i.e., furnaces contained within the same cabinet as an air conditioner) not covered by DOE 10 CFR 430 (i.e., three-phase power or with cooling capacity greater than or equal to 65,000 Btu/h) may comply with either rating. All other units greater than 225,000 Btu/h sold in the US must meet the AFUE standards for consumer products and test using USDOE's AFUE test procedure at DOE 10 CFR 430, Subpart B, Appendix N.
- Compliance of multiple firing rate units shall be at the maximum firing rate.
- $E_t$  = thermal efficiency. Units must also include an interrupted or intermittent ignition device (IID), have jacket losses not exceeding 0.75 percent of the input rating, and have either power venting or a flue damper. A vent damper is an acceptable alternative to a flue damper for those furnaces where combustion air is drawn from the conditioned space.
- $E_c$  = combustion efficiency (100 percent less flue losses). See test procedure for detailed discussion.
- Units must also include an interrupted or intermittent ignition device (IID) and have either power venting or an automatic flue damper.
- This table is a replica of ASHRAE 90.1 Table 6.8.1-5 Warm-Air Furnaces and Combination Warm-Air Furnaces/Air-Conditioning Units, Warm-Air Duct Furnaces, and Unit Heaters—Minimum Efficiency Requirements.

**TABLE C403.2.3(5)  
MINIMUM EFFICIENCY REQUIREMENTS: GAS- AND OIL-FIRED BOILERS**

EQUIPMENT TYPE <sup>a</sup>	SUBCATEGORY OR RATING CONDITION	SIZE CATEGORY (INPUT)	MINIMUM EFFICIENCY <sup>d,e</sup>	TEST PROCEDURE <sup>a</sup>
Boilers, hot water	Gas-fired	< 300,000 Btu/h	80% AFUE	10 CFR Part 430
		≥ 300,000 Btu/h and ≤ 2,500,000 Btu/h <sup>b</sup>	80% $E_t$	10 CFR Part 431
		> 2,500,000 Btu/h <sup>a</sup>	82% $E_c$	
	Oil-fired <sup>d</sup>	< 300,000 Btu/h	80% AFUE	10 CFR Part 430
		≥ 300,000 Btu/h and ≤ 2,500,000 Btu/h <sup>b</sup>	82% $E_t$	10 CFR Part 431
		> 2,500,000 Btu/h <sup>a</sup>	84% $E_c$	
Boilers, steam	Gas-fired	< 300,000 Btu/h	75% AFUE	10 CFR Part 430
	Gas-fired- all, except natural draft	≥ 300,000 Btu/h and ≤ 2,500,000 Btu/h <sup>b</sup>	79% $E_t$	10 CFR Part 431
		> 2,500,000 Btu/h <sup>a</sup>	79% $E_t$	
	Gas-fired-natural draft	≥ 300,000 Btu/h and ≤ 2,500,000 Btu/h <sup>b</sup>	77% $E_t$	
		> 2,500,000 Btu/h <sup>a</sup>	77% $E_t$	
	Oil-fired <sup>d</sup>	< 300,000 Btu/h	80% AFUE	10 CFR Part 430
		≥ 300,000 Btu/h and ≤ 2,500,000 Btu/h <sup>b</sup>	81% $E_t$	10 CFR Part 431
		> 2,500,000 Btu/h <sup>a</sup>	81% $E_t$	

For SI: 1 British thermal unit per hour = 0.2931 W.

- a. These requirements apply to boilers with rated input of 8,000,000 Btu/h or less that are not packaged boilers and to all packaged boilers. Minimum efficiency requirements for boilers cover all capacities of packaged boilers.
- b. Maximum capacity – minimum and maximum ratings as provided for and allowed by the unit's controls.
- c. Includes oil-fired (residual).
- d.  $E_t$  = Combustion efficiency (100 percent less flue losses).
- e.  $E_c$  = Thermal efficiency. See referenced standard for detailed information.

Note to RRC, Table C403.2.3(5) above is replaced with TABLE C403.3.2(6) below

**TABLE C403.3.2(6)  
GAS- AND OIL-FIRED BOILERS—MINIMUM EFFICIENCY REQUIREMENTS<sup>1</sup>**

<u>EQUIPMENT TYPE<sup>b</sup></u>	<u>SUBCATEGORY OR RATING CONDITION</u>	<u>SIZE CATEGORY (INPUT)</u>	<u>MINIMUM EFFICIENCY</u>	<u>EFFICIENCY AS OF 3/2/2022</u>	<u>TEST PROCEDURE<sup>a</sup></u>
Boilers, hot water	Gas fired	< 300,000 Btu/h <sup>g, h</sup> for applications outside US	82% AFUE	82% AFUE	DOE 10 CFR 430 Appendix N
		≥ 300,000 Btu/h and ≤ 2,500,000 Btu/h <sup>e</sup>	80% $E_t^d$	80% $E_t^d$	DOE 10 CFR 431.86
		> 2,500,000 Btu/h <sup>b</sup>	82% $E_c^c$	82% $E_c^c$	
	Oil fired <sup>d</sup>	< 300,000 Btu/h <sup>g, h</sup> for applications outside US	84% AFUE	84% AFUE	DOE 10 CFR 430 Appendix N
		≥ 300,000 Btu/h and ≤ 2,500,000 Btu/h <sup>e</sup>	82% $E_t^d$	82% $E_t^d$	DOE 10 CFR 431.86
		> 2,500,000 Btu/h <sup>b</sup>	84% $E_c^c$	84% $E_c^c$	
Boilers, steam	Gas fired	< 300,000 Btu/h <sup>g</sup> for applications outside US	80% AFUE	80% AFUE	DOE 10 CFR 430 Appendix N
	Gas fired—all, except natural draft	≥ 300,000 Btu/h and ≤ 2,500,000 Btu/h <sup>e</sup>	79% $E_t^d$	79% $E_t^d$	DOE 10 CFR 431.86
		> 2,500,000 Btu/h <sup>b</sup>	79% $E_t^d$	79% $E_t^d$	

	<u>Gas fired—natural draft</u>	<u>&gt; 300,000 Btu/h and ≤ 2,500,000 Btu/h<sup>c</sup></u>	<u>77% E<sub>t</sub><sup>d</sup></u>	<u>79% E<sub>t</sub><sup>d</sup></u>	
		<u>&gt; 2,500,000 Btu/h<sup>b</sup></u>	<u>77% E<sub>t</sub><sup>d</sup></u>	<u>79% E<sub>t</sub><sup>d</sup></u>	
	<u>Oil fired<sup>f</sup></u>	<u>&lt; 300,000 Btu/h<sup>g</sup> for applications outside US</u>	<u>82% AFUE</u>	<u>82% AFUE</u>	<u>DOE 10 CFR 430 Appendix N</u>
		<u>&gt; 300,000 Btu/h and ≤ 2,500,000 Btu/h<sup>c</sup></u>	<u>81% E<sub>t</sub><sup>d</sup></u>	<u>81% E<sub>t</sub><sup>d</sup></u>	<u>DOE 10 CFR 431.86</u>
		<u>&gt; 2,500,000 Btu/h<sup>b</sup></u>	<u>81% E<sub>t</sub><sup>d</sup></u>	<u>81% E<sub>t</sub><sup>d</sup></u>	

For SI: 1 British thermal unit per hour = 0.2931 W.

- a. Chapter 6 contains a complete specification of the referenced standards, which include test procedures, including the reference year version of the test procedure.
- b. These requirements apply to boilers with rated input of 8,000,000 Btu/h or less that are not packaged boilers and to all packaged boilers. Minimum efficiency requirements for boilers cover all capacities of packaged boilers.
- c. E<sub>c</sub> = Combustion efficiency (100 percent less flue losses).
- d. E<sub>t</sub> = Thermal efficiency.
- e. Maximum capacity—minimum and maximum ratings as provided for and allowed by the unit's controls.
- f. Includes oil-fired (residual).
- g. Boilers shall not be equipped with a constant burning pilot light.
- h. A boiler not equipped with a tankless domestic water-heating coil shall be equipped with an automatic means for adjusting the temperature of the water such that an incremental change in inferred heat load produces a corresponding incremental change in the temperature of the water supplied.
- i. This table is a replica of ASHRAE 90.1 Table 6.8.1-6 Gas- and Oil-Fired Boilers—Minimum Efficiency Requirements.

**TABLE C403.2.3(6)  
MINIMUM EFFICIENCY REQUIREMENTS:  
CONDENSING UNITS, ELECTRICALLY OPERATED**

<b>EQUIPMENT TYPE</b>	<b>SIZE CATEGORY</b>	<b>MINIMUM EFFICIENCY<sup>b</sup></b>	<b>TEST PROCEDURE<sup>a</sup></b>
Condensing units, air cooled	≥ 135,000 Btu/h	10.1 EER 11.2 IPLV	AHRI 365
Condensing units, water or evaporatively cooled	≥ 135,000 Btu/h	13.1 EER 13.1 IPLV	

For SI: 1 British thermal unit per hour = 0.2931 W.

- a. Chapter 6 contains a complete specification of the referenced test procedure, including the referenced year version of the test procedure.
- b. IPLVs are only applicable to equipment with capacity modulation.

**TABLE C403.2.3(7)  
WATER CHILLING PACKAGES – EFFICIENCY REQUIREMENTS<sup>a, b, d</sup>**

EQUIPMENT TYPE	SIZE CATEGORY	UNITS	BEFORE 1/1/2015		AS OF 1/1/2015		TEST PROCEDURE <sup>c</sup>
			Path A	Path B	Path A	Path B	
Air-cooled chillers	< 150 Tons	EER (Btu/W)	≥ 9.562 FL	NA <sup>c</sup>	≥ 10.100 FL	≥ 9.700 FL	AHRI 550/590
			≥ 12.500 IPLV		≥ 13.700 IPLV	≥ 15.800 IPLV	
	≥ 150 Tons		≥ 9.562 FL	NA <sup>c</sup>	≥ 10.100 FL	≥ 9.700 FL	
			≥ 12.500 IPLV		≥ 14.000 IPLV	≥ 16.100 IPLV	
Air cooled without condenser, electrically operated	All capacities	EER (Btu/W)	Air-cooled chillers without condenser shall be rated with matching condensers and complying with air-cooled chiller efficiency requirements.				
Water cooled, electrically operated positive displacement	< 75 Tons	kW/ton	≤ 0.780 FL	≤ 0.800 FL	≤ 0.750 FL	≤ 0.780 FL	AHRI 550/590
			≤ 0.630 IPLV	≤ 0.600 IPLV	≤ 0.600 IPLV	≤ 0.500 IPLV	
	≥ 75 tons and < 150 tons		≤ 0.775 FL	≤ 0.790 FL	≤ 0.750 FL	≤ 0.750 FL	
			≤ 0.615 IPLV	≤ 0.586 IPLV	≤ 0.560 IPLV	≤ 0.490 IPLV	
	≥ 150 tons and < 300 tons		≤ 0.680 FL	≤ 0.718 FL	≤ 0.660 FL	≤ 0.680 FL	
			≤ 0.580 IPLV	≤ 0.540 IPLV	≤ 0.540 IPLV	≤ 0.440 IPLV	
≥ 300 tons and < 600 tons	≤ 0.620 FL	≤ 0.639 FL	≤ 0.610 FL	≤ 0.625 FL			
	≤ 0.540 IPLV	≤ 0.490 IPLV	≤ 0.520 IPLV	≤ 0.410 IPLV			
≥ 600 tons	≤ 0.620 FL	≤ 0.639 FL	≤ 0.560 FL	≤ 0.585 FL			
	≤ 0.540 IPLV	≤ 0.490 IPLV	≤ 0.500 IPLV	≤ 0.380 IPLV			
Water cooled, electrically operated centrifugal	< 150 Tons	kW/ton	≤ 0.634 FL	≤ 0.639 FL	≤ 0.610 FL	≤ 0.695 FL	AHRI 550/590
			≤ 0.596 IPLV	≤ 0.450 IPLV	≤ 0.550 IPLV	≤ 0.440 IPLV	
	≥ 150 tons and < 300 tons		≤ 0.634 FL	≤ 0.639 FL	≤ 0.610 FL	≤ 0.635 FL	
			≤ 0.596 IPLV	≤ 0.450 IPLV	≤ 0.550 IPLV	≤ 0.400 IPLV	
	≥ 300 tons and < 400 tons		≤ 0.576 FL	≤ 0.600 FL	≤ 0.560 FL	≤ 0.595 FL	
			≤ 0.549 IPLV	≤ 0.400 IPLV	≤ 0.520 IPLV	≤ 0.390 IPLV	
≥ 400 tons and < 600 tons	≤ 0.576 FL	≤ 0.600 FL	≤ 0.560 FL	≤ 0.585 FL			
	≤ 0.549 IPLV	≤ 0.400 IPLV	≤ 0.500 IPLV	≤ 0.380 IPLV			
≥ 600 Tons	≤ 0.570 FL	≤ 0.590 FL	≤ 0.560 FL	≤ 0.585 FL			
	≤ 0.539 IPLV	≤ 0.400 IPLV	≤ 0.500 IPLV	≤ 0.380 IPLV			
Air cooled, absorption, single effect	All capacities	COP	≥ 0.600 FL	NA <sup>c</sup>	≥ 0.600 FL	NA <sup>c</sup>	AHRI 560
Water cooled absorption, single effect	All capacities	COP	≥ 0.700 FL	NA <sup>c</sup>	≥ 0.700 FL	NA <sup>c</sup>	
Absorption, double effect, indirect fired	All capacities	COP	≥ 1.000 FL	NA <sup>c</sup>	≥ 1.000 FL	NA <sup>c</sup>	
			≥ 1.050 IPLV		≥ 1.050 IPLV		
Absorption double effect direct fired	All capacities	COP	≥ 1.000 FL	NA <sup>c</sup>	≥ 1.000 FL	NA <sup>c</sup>	
			≥ 1.000 IPLV		≥ 1.050 IPLV		

- a. The requirements for centrifugal chiller shall be adjusted for nonstandard rating conditions in accordance with Section C403.2.3.1 and are only applicable for the range of conditions listed in Section C403.2.3.1. The requirements for air-cooled, water-cooled positive displacement and absorption chillers are at standard rating conditions defined in the reference test procedure.
- b. Both the full-load and IPLV requirements shall be met or exceeded to comply with this standard. Where there is a Path B, compliance can be with either Path A or Path B for any application.
- c. NA means the requirements are not applicable for Path B and only Path A can be used for compliance.
- d. FL represents the full-load performance requirements and IPLV the part-load performance requirements.

**[Note to RRC – Table C403.2.3(7) from 2018 above replaced with Table C403.3.2(3) below]**

**TABLE C403.3.2(3)  
WATER-CHILLING PACKAGES—MINIMUM EFFICIENCY REQUIREMENTS<sup>a, b, e, f</sup>**

EQUIPMENT TYPE	SIZE CATEGORY	UNITS	PATH A	PATH B	TEST PROCEDURE <sup>c</sup>
Air cooled chillers	< 150 tons	EER (Btu/Wh)	≥ 10.100 FL	≥ 9.700 FL	AHRI 550/590
			≥ 13.700 IPLV.IP	≥ 15.800 IPLV.IP	
	≥ 10.100 FL		≥ 9.700FL		
	≥ 14.000 IPLV.IP		≥ 16.100 IPLV.IP		
	≥ 150 tons				
Air cooled without condenser, electrically operated	All capacities	EER (Btu/Wh)	Air-cooled chillers without condenser must be rated with matching condensers and comply with air-cooled chiller efficiency requirements		AHRI 550/590

<u>Water cooled, electrically operated positive displacement</u>	<u>&lt; 75 tons</u>	<u>kW/ton</u>	<u>≤ 0.750 FL</u>	<u>≤ 0.780 FL</u>	<u>AHRI 550/590</u>
			<u>≤ 0.600 IPLV.IP</u>	<u>≤ 0.500 IPLV.IP</u>	
	<u>≥ 75 tons and &lt; 150 tons</u>		<u>≤ 0.720 FL</u>	<u>≤ 0.750 FL</u>	
			<u>≤ 0.560 IPLV.IP</u>	<u>≤ 0.490 IPLV.IP</u>	
	<u>≥ 150 tons and &lt; 300 tons</u>		<u>≤ 0.660 FL</u>	<u>≤ 0.680 FL</u>	
			<u>≤ 0.540 IPLV.IP</u>	<u>≤ 0.440 IPLV.IP</u>	
	<u>≥ 300 tons and &lt; 600 tons</u>		<u>≤ 0.610 FL</u>	<u>≤ 0.625 FL</u>	
			<u>≤ 0.520 IPLV.IP</u>	<u>≤ 0.410 IPLV.IP</u>	
<u>≥ 600 tons</u>	<u>≤ 0.560 FL</u>	<u>≤ 0.585 FL</u>			
		<u>≤ 0.500 IPLV.IP</u>	<u>≤ 0.380 IPLV.IP</u>		
<u>Water cooled, electrically operated centrifugal</u>	<u>&lt; 150 tons</u>	<u>kW/ton</u>	<u>≤ 0.610 FL</u>	<u>≤ 0.695 FL</u>	<u>AHRI 550/590</u>
			<u>≤ 0.550 IPLV.IP</u>	<u>≤ 0.440 IPLV.IP</u>	
			<u>≤ 0.610 FL</u>	<u>≤ 0.635 FL</u>	
			<u>≤ 0.550 IPLV.IP</u>	<u>≤ 0.400 IPLV.IP</u>	
	<u>≥ 300 tons and &lt; 400 tons</u>		<u>≤ 0.560 FL</u>	<u>≤ 0.595 FL</u>	
			<u>≤ 0.520 IPLV.IP</u>	<u>≤ 0.390 IPLV.IP</u>	
	<u>≥ 400 tons and &lt; 600 tons</u>		<u>≤ 0.560 FL</u>	<u>≤ 0.585 FL</u>	
			<u>≤ 0.500 IPLV.IP</u>	<u>≤ 0.380 IPLV.IP</u>	
<u>≥ 600 tons</u>	<u>≤ 0.560 FL</u>	<u>≤ 0.585 FL</u>			
		<u>≤ 0.500 IPLV.IP</u>	<u>≤ 0.380 IPLV.IP</u>		
<u>Air cooled absorption, single effect</u>	<u>All capacities</u>	<u>COP (W/W)</u>	<u>≥ 0.600 FL</u>	<u>NA<sup>d</sup></u>	<u>AHRI 560</u>
<u>Water cooled absorption, single effect</u>	<u>All capacities</u>	<u>COP (W/W)</u>	<u>≥ 0.700 FL</u>	<u>NA<sup>d</sup></u>	<u>AHRI 560</u>
<u>Absorption double effect, indirect fired</u>	<u>All capacities</u>	<u>COP (W/W)</u>	<u>≥ 1.000 FL</u>	<u>NA<sup>d</sup></u>	<u>AHRI 560</u>
			<u>≥ 0.150 IPLV.IP</u>		
<u>Absorption double effect, direct fired</u>	<u>All capacities</u>	<u>COP (W/W)</u>	<u>≥ 1.000 FL</u>	<u>NA<sup>d</sup></u>	<u>AHRI 560</u>
			<u>≥ 1.000 IPLV</u>		

- a. Chapter 6 contains a complete specification of the referenced standards, which include test procedures, including the reference year version of the test procedure.
- b. The requirements for centrifugal chillers shall be adjusted for nonstandard rating conditions per Section C403.3.2.1 and are applicable only for the range of conditions listed there. The requirements for air-cooled, water-cooled positive displacement and absorption chillers are at standard rating conditions defined in the reference test procedure.
- c. Both the full-load and IPLV.IP requirements must be met or exceeded to comply with this standard. When there is a Path B, compliance can be with either Path A or Path B for any application.

- d. NA means the requirements are not applicable for Path B, and only Path A can be used for compliance.
- e. FL is the full-load performance requirements, and IPLV/IP is for the part-load performance requirements.
- f. This table is a replica of ASHRAE 90.1 Table 6.8.1-3 Water-Chilling Packages—Minimum Efficiency Requirements.

**TABLE C403.2.3(8)  
MINIMUM EFFICIENCY REQUIREMENTS:  
HEAT REJECTION EQUIPMENT**

EQUIPMENT TYPE*	TOTAL SYSTEM HEAT REJECTION CAPACITY AT RATED CONDITIONS	SUBCATEGORY OR RATING CONDITION <sup>1</sup>	PERFORMANCE REQUIRED <sup>2,3,4,5,6</sup>	TEST PROCEDURE <sup>7</sup>
Propeller or axial fan open-circuit cooling towers	All	95°F entering water 85°F leaving water 75°F entering wb	≥ 40.2 gpm/hp	CTI ATC-105 and CTI STD-201
Centrifugal fan open-circuit cooling towers	All	95°F entering water 85°F leaving water 75°F entering wb	≥ 20.0 gpm/hp	CTI ATC-105 and CTI STD-201
Propeller or axial fan closed-circuit cooling towers	All	102°F entering water 90°F leaving water 75°F entering wb	≥ 14.0 gpm/hp	CTI ATC-105S and CTI STD-201
Centrifugal fan closed-circuit cooling towers	All	102°F entering water 90°F leaving water 75°F entering wb	≥ 7.0 gpm/hp	CTI ATC-105S and CTI STD-201
Propeller or axial fan evaporative condensers	All	Ammonia Test Fluid 140°F entering gas temperature 96.3°F condensing temperature 75°F entering wb	≥ 134,000 Btu/h-hp	CTI ATC-106
Centrifugal fan evaporative condensers	All	Ammonia Test Fluid 140°F entering gas temperature 96.3°F condensing temperature 75°F entering wb	≥ 110,000 Btu/h-hp	CTI ATC-106
Propeller or axial fan evaporative condensers	All	R-507A Test Fluid 165°F entering gas temperature 105°F condensing temperature 75°F entering wb	≥ 157,000 Btu/h-hp	CTI ATC-106
Centrifugal fan evaporative condensers	All	R-507A Test Fluid 165°F entering gas temperature 105°F condensing temperature 75°F entering wb	≥ 135,000 Btu/h-hp	CTI ATC-106
Air-cooled condensers	All	125°F Condensing Temperature 190°F Entering Gas Temperature 15°F subcooling 95°F entering db	≥ 176,000 Btu/h-hp	AHRI 460

For SI: °C = [(°F)-32]/1.8, L/s · kW = (gpm/hp)/(11.83), COP = (Btu/h · hp)/(2550.7),  
db = dry bulb temperature, °F, wb = wet bulb temperature, °F.

- a. The efficiencies and test procedures for both open- and closed-circuit cooling towers are not applicable to hybrid cooling towers that contain a combination of wet and dry heat exchange sections.
- b. For purposes of this table, open-circuit cooling tower performance is defined as the water flow rating of the tower at the thermal rating condition listed in Table 403.2.3(8) divided by the fan nameplate-rated motor power.
- c. For purposes of this table, closed-circuit cooling tower performance is defined as the water flow rating of the tower at the thermal rating condition listed in Table 403.2.3(8) divided by the sum of the fan nameplate-rated motor power and the spray pump nameplate-rated motor power.
- d. For purposes of this table, air-cooled condenser performance is defined as the heat rejected from the refrigerant divided by the fan nameplate-rated motor power.
- e. Chapter 6 contains a complete specification of the referenced test procedure, including the referenced year version of the test procedure. The certification requirements do not apply to field-erected cooling towers.
- f. Where a certification program exists for a covered product and it includes provisions for verification and challenge of equipment efficiency ratings, then the product shall be listed in the certification program; or, where a certification program exists for a covered product, and it includes provisions for verification and challenge of equipment efficiency ratings, but the product is not listed in the existing certification program, the ratings shall be verified by an independent laboratory test report.
- g. Cooling towers shall comply with the minimum efficiency listed in the table for that specific type of tower with the capacity effect of any project-specific accessories and/or options included in the capacity of the cooling tower.
- h. For purposes of this table, evaporative condenser performance is defined as the heat rejected at the specified rating condition in the table divided by the sum of the fan motor nameplate power and the integral spray pump nameplate power.
- i. Requirements for evaporative condensers are listed with ammonia (R-717) and R-507A as test fluids in the table. Evaporative condensers intended for use with halocarbon refrigerants other than R-507A shall meet the minimum efficiency requirements listed in this table with R-507A as the test fluid.

**[Note to RRC— Table C403.2.3(8) from 2018 above replaced with Table C403.3.2(7) below]**

**TABLE C403.3.2(7)**

**PERFORMANCE REQUIREMENTS FOR HEAT REJECTION EQUIPMENT—MINIMUM EFFICIENCY REQUIREMENTS<sup>1</sup>**



<u>EQUIPMENT TYPE</u>	<u>TOTAL SYSTEM HEAT-REJECTION CAPACITY AT RATED CONDITIONS</u>	<u>SUBCATEGORY OR RATING CONDITION<sup>b</sup></u>	<u>PERFORMANCE REQUIRED<sup>b, c, d, f, g</sup></u>	<u>TEST PROCEDURE<sup>a, e</sup></u>
<u>Propeller or axial fan open-circuit cooling towers</u>	<u>All</u>	<u>95°F entering water</u> <u>85°F leaving water</u> <u>75°F entering wb</u>	<u>≥ 40.2 gpm/hp</u>	<u>CTI ATC-105 and CTI STD-201 RS</u>
<u>Centrifugal fan open-circuit cooling towers</u>	<u>All</u>	<u>95°F entering water</u> <u>85°F leaving water</u> <u>75°F entering wb</u>	<u>≥ 20.0 gpm/hp</u>	<u>CTI ATC-105 and CTI STD-201 RS</u>
<u>Propeller or axial fan closed-circuit cooling towers</u>	<u>All</u>	<u>102°F entering water</u> <u>90°F leaving water</u> <u>75°F entering wb</u>	<u>≥ 14.0 gpm/hp</u> <u>≥ 16.1 gpm/hp</u>	<u>CTI ATC-105S and CTI STD-201 RS</u>
<u>Centrifugal fan closed-circuit cooling towers</u>	<u>All</u>	<u>102°F entering water</u> <u>90°F leaving water</u> <u>75°F entering wb</u>	<u>≥ 7.0 gpm/hp</u>	<u>CTI ATC-105S and CTI STD-201 RS</u>
<u>Propeller or axial fan dry coolers (air-cooled fluid coolers)</u>	<u>All</u>	<u>115°F entering water</u> <u>105°F leaving water</u> <u>95°F entering wb</u>	<u>≥ 4.5 gpm/hp</u>	<u>CTI ATC-105DS</u>
<u>Propeller or axial fan evaporative condensers</u>	<u>All</u>	<u>R-448A test fluid</u> <u>165°F entering gas temperature</u> <u>105°F condensing temperature</u> <u>75°F entering wb</u>	<u>≥ 160,000 Btu/h × hp</u>	<u>CTI ATC-106</u>
<u>Propeller or axial fan evaporative condensers</u>	<u>All</u>	<u>Ammonia test fluid</u> <u>140°F entering gas temperature</u> <u>96.3°F condensing temperature</u> <u>75°F entering wb</u>	<u>≥ 134,000 Btu/h × hp</u>	<u>CTI ATC-106</u>
<u>Centrifugal fan evaporative condensers</u>	<u>All</u>	<u>R-448A test fluid</u> <u>165°F entering gas temperature</u> <u>105°F condensing temperature</u> <u>75°F entering wb</u>	<u>≥ 137,000 Btu/h × hp</u>	<u>CTI ATC-106</u>
<u>Centrifugal fan evaporative condensers</u>	<u>All</u>	<u>Ammonia test fluid</u> <u>140°F entering gas temperature</u> <u>96.3°F condensing temperature</u> <u>75°F entering wb</u>	<u>≥ 110,000 Btu/h × hp</u>	<u>CTI ATC-106</u>
<u>Air-cooled condensers</u>	<u>All</u>	<u>125°F condensing temperature</u> <u>190°F entering gas temperature</u> <u>15°F subcooling</u> <u>95°F entering db</u>	<u>≥ 176,000 Btu/h × hp</u>	<u>AHRI 460</u>

For SI: °C = [(°F) – 32]/1.8, L/s × kW = (gpm/hp)/(11.83), COP = (Btu/h × hp)/(2550.7), db = dry bulb temperature, wb = wet bulb temperature.

- a. Chapter 6 contains a complete specification of the referenced standards, which include test procedures, including the reference year version of the test procedure.
- b. For purposes of this table, open-circuit cooling tower performance is defined as the water-flow rating of the tower at the thermal rating condition listed in the table divided by the fan motor nameplate power.
- c. For purposes of this table, closed-circuit cooling tower performance is defined as the process water-flow rating of the tower at the thermal rating condition listed in the table divided by the sum of the fan motor nameplate power and the integral spray pump motor nameplate power.
- d. For purposes of this table, dry-cooler performance is defined as the process water-flow rating of the unit at the thermal rating condition listed in the table divided by the total fan motor nameplate power of the unit, and air-cooled condenser performance is defined as the heat rejected from the refrigerant divided by the total fan motor nameplate power of the unit.
- e. The efficiencies and test procedures for both open- and closed-circuit cooling towers are not applicable to hybrid cooling towers that contain a combination of separate wet and dry heat exchange sections. The certification requirements do not apply to field-erected cooling towers.
- f. All cooling towers shall comply with the minimum efficiency listed in the table for that specific type of tower with the capacity effect of any project-specific accessories and/or options included in the capacity of the cooling tower.
- g. For purposes of this table, evaporative condenser performance is defined as the heat rejected at the specified rating condition in the table, divided by the sum of the fan motor nameplate power and the integral spray pump nameplate power.
- h. Requirements for evaporative condensers are listed with ammonia (R-717) and R-448A as test fluids in the table. Evaporative condensers intended for use with halocarbon refrigerants other than R-448A must meet the minimum efficiency requirements listed with R-448A as the test fluid. For ammonia, the condensing temperature is defined as the saturation temperature corresponding to the refrigerant pressure at the condenser entrance. For R-448A, which is a zeotropic refrigerant, the condensing temperature is defined as the arithmetic average of the dew point and the bubble point temperatures corresponding to the refrigerant pressure at the condenser entrance.
- i. This table is a replica of ASHRAE 90.1 Table 6.8.1-7 Performance Requirements for Heat Rejection Equipment—Minimum Efficiency Requirements.

**TABLE C403.3.2(8)**

**ELECTRICALLY OPERATED VARIABLE-REFRIGERANT-FLOW AIR CONDITIONERS—MINIMUM EFFICIENCY REQUIREMENTS<sup>b</sup>**

<u>EQUIPMENT TYPE</u>	<u>SIZE CATEGORY</u>	<u>HEATING SECTION TYPE</u>	<u>SUBCATEGORY OR RATING CONDITION</u>	<u>MINIMUM EFFICIENCY</u>	<u>TEST PROCEDURE<sup>a</sup></u>
<u>VRF air conditioners, air cooled</u>	<u>&lt; 65,000 Btu/h</u>	<u>All</u>	<u>VRF multisplit system</u>	<u>13.0 SEER</u>	<u>AHRI 1230</u>
	<u>&gt; 65,000 Btu/h and &lt; 135,000 Btu/h</u>	<u>Electric resistance (or none)</u>	<u>VRF multisplit system</u>	<u>11.2 EER</u> <u>13.1 IEER</u> <u>15.5 IEER</u>	
	<u>&gt; 135,000 Btu/h and &lt; 240,000 Btu/h</u>	<u>Electric resistance (or none)</u>	<u>VRF multisplit system</u>	<u>11.0 EER</u> <u>12.9 IEER</u> <u>14.9 IEER</u>	
	<u>&gt; 240,000 Btu/h</u>	<u>Electric resistance (or none)</u>	<u>VRF multisplit system</u>	<u>10.0 EER</u> <u>11.6 IEER</u> <u>13.9 IEER</u>	

For SI: 1 British thermal unit per hour = 0.2931 W.

- a. Chapter 6 contains a complete specification of the referenced standards, which include test procedures, including the reference year version of the test procedure.
- b. This table is a replica of ASHRAE 90.1 Table 6.8.1-8 Electrically Operated Variable-Refrigerant-Flow Air Conditioners—Minimum Efficiency Requirements.

**TABLE C403.3.2(9)**

**ELECTRICALLY OPERATED VARIABLE-REFRIGERANT-FLOW AND APPLIED HEAT PUMPS—MINIMUM EFFICIENCY REQUIREMENTS<sup>b</sup>**

<u>EQUIPMENT TYPE</u>	<u>SIZE CATEGORY</u>	<u>HEATING SECTION TYPE</u>	<u>SUBCATEGORY OR RATING CONDITION</u>	<u>MINIMUM EFFICIENCY</u>	<u>TEST PROCEDURE<sup>a</sup></u>
<u>VRF air cooled (cooling mode)</u>	<u>&lt; 65,000 Btu/h</u>	<u>All</u>	<u>VRF multisplit system</u>	<u>13.0 SEER</u>	<u>AHRI 1230</u>
	<u>&gt; 65,000 Btu/h and &lt; 135,000 Btu/h</u>	<u>Electric resistance (or none)</u>		<u>11.0 EER</u> <u>12.9 IEER</u> <u>14.6 IEER</u>	
			<u>VRF multisplit system with heat recovery</u>	<u>10.8 EER</u> <u>12.7 IEER</u> <u>14.4 IEER</u>	

	<u>&gt; 135,000 Btu/h and &lt; 240,000 Btu/h</u>		<u>VRF multisplit system</u>	<u>10.6 EER</u> <u>12.3 IEER</u> <u>13.9 IEER</u>	
			<u>VRF multisplit system with heat recovery</u>	<u>10.4 EER</u> <u>12.1 IEER</u> <u>13.7 IEER</u>	
	<u>≥ 240,000 Btu/h</u>		<u>VRF multisplit system</u>	<u>9.5 EER</u> <u>11.0 IEER</u> <u>12.7 IEER</u>	
			<u>VRF multisplit system with heat recovery</u>	<u>9.3 EER</u> <u>10.8 IEER</u> <u>12.5 IEER</u>	
<u>VRF water source (cooling mode)</u>	<u>&lt; 65,000 Btu/h</u>	<u>All</u>	<u>VRF multisplit systems 86°F entering water</u>	<u>12.0 EER</u> <u>16.0 IEER</u>	<u>AHRI 1230</u>
			<u>VRF multisplit systems with heat recovery 86°F entering water</u>	<u>11.8 EER</u> <u>15.8 IEER</u>	
	<u>VRF multisplit system 86°F entering water</u>		<u>12.0 EER</u> <u>16.0 IEER</u>		
	<u>VRF multisplit system with heat recovery 86°F entering water</u>		<u>11.8 EER</u> <u>15.8 IEER</u>		
	<u>VRF multisplit system 86°F entering water</u>		<u>10.0 EER</u> <u>14.0 IEER</u>		
	<u>VRF multisplit system with heat recovery 86°F entering water</u>		<u>9.8 EER</u> <u>13.8 IEER</u>		
	<u>VRF multisplit system 86°F entering water</u>		<u>10.0 EER</u> <u>12.0 IEER</u>		
	<u>VRF multisplit system with heat recovery 86°F entering water</u>		<u>9.8 EER</u> <u>11.8 IEER</u>		
<u>&gt; 65,000 Btu/h and &lt; 135,000 Btu/h</u>	<u>&gt; 135,000 Btu/h and &lt; 240,000 Btu/h</u>	<u>&gt; 240,000 Btu/h</u>	<u>VRF multisplit system 59°F entering water</u>	<u>16.2 EER</u>	<u>AHRI 1230</u>
			<u>VRF multisplit system with heat recovery 59°F entering water</u>	<u>16.0 EER</u>	
<u>VRF multisplit system 59°F entering water</u>	<u>13.8 EER</u>				
<u>VRF multisplit system with heat recovery 59°F entering water</u>	<u>13.6 EER</u>				

<u>EQUIPMENT TYPE</u>	<u>SIZE CATEGORY</u>	<u>HEATING SECTION TYPE</u>	<u>SUBCATEGORY OR RATING CONDITION</u>	<u>MINIMUM EFFICIENCY</u>	<u>TEST PROCEDURE<sup>a</sup></u>
	<u>&lt; 135,000 Btu/h</u>	<u>All</u>	<u>VRF multisplit system 77°F entering water</u>	<u>13.4 EER</u>	<u>AHRI 1230</u>

<u>VRF ground source (cooling mode)</u>		<u>VRF multisplit system with heat recovery 77°F entering water</u>	<u>13.2 EER</u>	
	<u>≥ 135,000 Btu/h</u>	<u>VRF multisplit system 77°F entering water</u>	<u>11.0 EER</u>	
<u>VRF air cooled (heating mode)</u>	<u>&lt; 65,000 Btu/h (cooling capacity)</u>	<u>VRF multisplit system with heat recovery 77°F entering water</u>	<u>10.8 EER</u>	
	<u>≥ 65,000 Btu/h and &lt; 135,000 Btu/h (cooling capacity)</u>	<u>VRF multisplit system</u>	<u>7.7 HSPF</u>	<u>AHRI 1230</u>
	<u>≥ 135,000 Btu/h (cooling capacity)</u>	<u>VRF multisplit system 47°F db/43°F wb outdoor air</u>	<u>3.3 COP<sub>H</sub></u>	
	<u>17°F db/15°F wb outdoor air</u>	<u>2.25 COP<sub>H</sub></u>		
<u>VRF water source (heating mode)</u>	<u>&lt; 65,000 Btu/h (cooling capacity)</u>	<u>VRF multisplit system 47°F db/43°F wb outdoor air</u>	<u>3.2 COP<sub>H</sub></u>	<u>AHRI 1230</u>
	<u>≥ 65,000 Btu/h and &lt; 135,000 Btu/h (cooling capacity)</u>	<u>17°F db/15°F wb outdoor air</u>	<u>2.05 COP<sub>H</sub></u>	
	<u>≥ 135,000 Btu/h and &lt; 240,000 Btu/h (cooling capacity)</u>	<u>VRF multisplit system 68°F entering water</u>	<u>4.2 COP<sub>H</sub></u> <u>4.3 COP<sub>H</sub></u>	
	<u>≥ 240,000 Btu/h (cooling capacity)</u>	<u>VRF multisplit system 68°F entering water</u>	<u>4.2 COP<sub>H</sub></u> <u>4.3 COP<sub>H</sub></u>	
<u>VRF groundwater source (heating mode)</u>	<u>&lt; 135,000 Btu/h (cooling capacity)</u>	<u>VRF multisplit system 68°F entering water</u>	<u>3.9 COP<sub>H</sub></u> <u>4.0 COP<sub>H</sub></u>	<u>AHRI 1230</u>
	<u>≥ 135,000 Btu/h (cooling capacity)</u>	<u>VRF multisplit system 68°F entering water</u>	<u>3.9 COP<sub>H</sub></u>	
<u>VRF ground source (heating mode)</u>	<u>&lt; 135,000 Btu/h (cooling capacity)</u>	<u>VRF multisplit system 50°F entering water</u>	<u>3.6 COP<sub>H</sub></u>	<u>AHRI 1230</u>
	<u>≥ 135,000 Btu/h (cooling capacity)</u>	<u>VRF multisplit system 50°F entering water</u>	<u>3.3 COP<sub>H</sub></u>	
<u>VRF ground source (heating mode)</u>	<u>&lt; 135,000 Btu/h (cooling capacity)</u>	<u>VRF multisplit system 32°F entering water</u>	<u>3.1 COP<sub>H</sub></u>	<u>AHRI 1230</u>
	<u>≥ 135,000 Btu/h (cooling capacity)</u>	<u>VRF multisplit system 32°F entering water</u>	<u>2.8 COP<sub>H</sub></u>	

For SI: °C = [(°F) – 32]/1.8, 1 British thermal unit per hour = 0.2931 W, db = dry bulb temperature, wb = wet bulb temperature.

- Chapter 6 contains a complete specification of the referenced standards, which include test procedures, including the reference year version of the test procedure.
- This table is a replica of ASHRAE 90.1 Table 6.8.1-9 Electrically Operated Variable-Refrigerant-Flow and Applied Heat Pumps—Minimum Efficiency Requirements.

**TABLE C403.2.3(9)**  
**MINIMUM EFFICIENCY AIR CONDITIONERS AND CONDENSING UNITS SERVING COMPUTER ROOMS**

EQUIPMENT TYPE	NET SENSIBLE COOLING CAPACITY <sup>a</sup>	MINIMUM SCOP-127 <sup>b</sup> EFFICIENCY DOWNFLOW UNITS / UPFLOW UNITS	TEST PROCEDURE
Air conditioners, air cooled	< 65,000 Btu/h	2.20 / 2.09	ANSI/ASHRAE 127
	≥ 65,000 Btu/h and < 240,000 Btu/h	2.10 / 1.99	
	≥ 240,000 Btu/h	1.90 / 1.79	
Air conditioners, water cooled	< 65,000 Btu/h	2.60 / 2.49	
	≥ 65,000 Btu/h and < 240,000 Btu/h	2.50 / 2.39	
	≥ 240,000 Btu/h	2.40 / 2.29	
Air conditioners, water cooled with fluid economizer	< 65,000 Btu/h	2.55 / 2.44	
	≥ 65,000 Btu/h and < 240,000 Btu/h	2.45 / 2.34	
	≥ 240,000 Btu/h	2.35 / 2.24	
Air conditioners, glycol cooled (rated at 40% propylene glycol)	< 65,000 Btu/h	2.50 / 2.39	
	≥ 65,000 Btu/h and < 240,000 Btu/h	2.15 / 2.04	
	≥ 240,000 Btu/h	2.10 / 1.99	
Air conditioners, glycol cooled (rated at 40% propylene glycol) with fluid economizer	< 65,000 Btu/h	2.45 / 2.34	
	≥ 65,000 Btu/h and < 240,000 Btu/h	2.10 / 1.99	
	≥ 240,000 Btu/h	2.05 / 1.94	

For SI: 1 British thermal unit per hour = 0.2931 W.

- a. Net sensible cooling capacity: the total gross cooling capacity less the latent cooling less the energy to the air movement system. (Total Gross – Latent – Fan Power)
- b. Sensible coefficient of performance (SCOP-127): a ratio calculated by dividing the net sensible cooling capacity in watts by the total power input in watts (excluding reheaters and humidifiers) at conditions defined in ASHRAE Standard 127. The net sensible cooling capacity is the gross sensible capacity minus the energy dissipated into the cooled space by the fan system.

**TABLE C403.3.2(10)**  
**FLOOR-MOUNTED AIR CONDITIONERS AND CONDENSING UNITS SERVING  
COMPUTER ROOMS—MINIMUM EFFICIENCY REQUIREMENTS<sup>b</sup>**

EQUIPMENT TYPE	STANDARD MODEL	NET SENSIBLE COOLING CAPACITY	MINIMUM NET SENSIBLE COP	RATING CONDITIONS RETURN AIR (dry bulb/dew point)	TEST PROCEDURE <sup>a</sup>
Air cooled	Downflow	< 80,000 Btu/h	2.70	85°F/52°F (Class 2)	AHRI 1360
		≥ 80,000 Btu/h and < 295,000 Btu/h	2.58		
		≥ 295,000 Btu/h	2.36		
	Upflow—ducted	< 80,000 Btu/h	2.67		
		≥ 80,000 Btu/h and < 295,000 Btu/h	2.55		
		≥ 295,000 Btu/h	2.33		
	Upflow—nonducted	< 65,000 Btu/h	2.16	75°F/52°F (Class 1)	
		≥ 65,000 Btu/h and < 240,000 Btu/h	2.04		
		≥ 240,000 Btu/h	1.89		
Horizontal	< 65,000 Btu/h	2.65	95°F/52°F (Class 3)		
	≥ 65,000 Btu/h and < 240,000 Btu/h	2.55			
	≥ 240,000 Btu/h	2.47			
Air cooled with fluid economizer	Downflow	< 80,000 Btu/h	2.70	85°F/52°F (Class 1)	AHRI 1360
		≥ 80,000 Btu/h and < 295,000 Btu/h	2.58		
		≥ 295,000 Btu/h	2.36		
	Upflow—ducted	< 80,000 Btu/h	2.67		

		$\geq 80,000$ Btu/h and $< 295,000$ Btu/h	<u>2.55</u>	75°F/52°F (Class 1)	
		$\geq 295,000$ Btu/h	<u>2.33</u>		
		$< 65,000$ Btu/h	<u>2.09</u>		
	Upflow—nonducted	$\geq 65,000$ Btu/h and $< 240,000$ Btu/h	<u>1.99</u>		
		$\geq 240,000$ Btu/h	<u>1.81</u>		
		Horizontal	$< 65,000$ Btu/h		<u>2.65</u>
	$\geq 65,000$ Btu/h and $< 240,000$ Btu/h		<u>2.55</u>		
	$\geq 240,000$ Btu/h		<u>2.47</u>		
	Water cooled	Downflow	$< 80,000$ Btu/h		<u>2.82</u>
$\geq 80,000$ Btu/h and $< 295,000$ Btu/h			<u>2.73</u>		
$\geq 295,000$ Btu/h			<u>2.67</u>		
Upflow—ducted		$< 80,000$ Btu/h	<u>2.79</u>		
		$\geq 80,000$ Btu/h and $< 295,000$ Btu/h	<u>2.70</u>		
		$\geq 295,000$ Btu/h	<u>2.64</u>		
Upflow—nonducted		$< 65,000$ Btu/h	<u>2.43</u>	75°F/52°F (Class 1)	
		$\geq 65,000$ Btu/h and $< 240,000$ Btu/h	<u>2.32</u>		
		$\geq 240,000$ Btu/h	<u>2.20</u>		
Horizontal		$< 65,000$ Btu/h	<u>2.79</u>	95°F/52°F (Class 3)	
		$\geq 65,000$ Btu/h and $< 240,000$ Btu/h	<u>2.68</u>		
		$\geq 240,000$ Btu/h	<u>2.60</u>		
AHRI 1360					

<u>EQUIPMENT TYPE</u>	<u>STANDARD MODEL</u>	<u>NET SENSIBLE COOLING CAPACITY</u>	<u>MINIMUM NET SENSIBLE COP</u>	<u>RATING CONDITIONS RETURN AIR (dry bulb/dew point)</u>	<u>TEST PROCEDURE<sup>a</sup></u>
Water cooled with fluid economizer	Downflow	$< 80,000$ Btu/h	<u>2.77</u>	85°F/52°F (Class 1)	
		$\geq 80,000$ Btu/h and $< 295,000$ Btu/h	<u>2.68</u>		
		$\geq 295,000$ Btu/h	<u>2.61</u>		
	Upflow—ducted	$< 80,000$ Btu/h	<u>2.74</u>		
		$\geq 80,000$ Btu/h and $< 295,000$ Btu/h	<u>2.65</u>		
		$\geq 295,000$ Btu/h	<u>2.58</u>		
	Upflow—nonducted	$< 65,000$ Btu/h	<u>2.35</u>		75°F/52°F (Class 1)
		$\geq 65,000$ Btu/h and $< 240,000$ Btu/h	<u>2.24</u>		
		$\geq 240,000$ Btu/h	<u>2.12</u>		
	Horizontal	$< 65,000$ Btu/h	<u>2.71</u>		95°F/52°F (Class 3)
		$\geq 65,000$ Btu/h and $< 240,000$ Btu/h	<u>2.60</u>		
	AHRI 1360				

		$\geq 240,000$ Btu/h	<u>2.54</u>		
Glycol cooled	Downflow	$< 80,000$ Btu/h	<u>2.56</u>	85°F/52°F (Class 1)	AHRI 1360
		$\geq 80,000$ Btu/h and $< 295,000$ Btu/h	<u>2.24</u>		
		$\geq 295,000$ Btu/h	<u>2.21</u>		
	Upflow—ducted	$< 80,000$ Btu/h	<u>2.53</u>		
		$\geq 80,000$ Btu/h and $< 295,000$ Btu/h	<u>2.21</u>		
		$\geq 295,000$ Btu/h	<u>2.18</u>		
	Upflow, nonducted	$< 65,000$ Btu/h	<u>2.08</u>	75°F/52°F (Class 1)	
		$\geq 65,000$ Btu/h and $< 240,000$ Btu/h	<u>1.90</u>		
		$\geq 240,000$ Btu/h	<u>1.81</u>		
	Horizontal	$< 65,000$ Btu/h	<u>2.48</u>	95°F/52°F (Class 3)	
$\geq 65,000$ Btu/h and $< 240,000$ Btu/h		<u>2.18</u>			
$\geq 240,000$ Btu/h		<u>2.18</u>			
Glycol cooled with fluid economizer	Downflow	$< 80,000$ Btu/h	<u>2.51</u>	85°F/52°F (Class 1)	AHRI 1360
		$\geq 80,000$ Btu/h and $< 295,000$ Btu/h	<u>2.19</u>		
		$\geq 295,000$ Btu/h	<u>2.15</u>		
	Upflow—ducted	$< 80,000$ Btu/h	<u>2.48</u>		
		$\geq 80,000$ Btu/h and $< 295,000$ Btu/h	<u>2.16</u>		
		$\geq 295,000$ Btu/h	<u>2.12</u>		
	Upflow—nonducted	$< 65,000$ Btu/h	<u>2.00</u>	75°F/52°F (Class 1)	
		$\geq 65,000$ Btu/h and $< 240,000$ Btu/h	<u>1.82</u>		
		$\geq 240,000$ Btu/h	<u>1.73</u>		
	Horizontal	$< 65,000$ Btu/h	<u>2.44</u>	95°F/52°F (Class 3)	
		$\geq 65,000$ Btu/h and $< 240,000$ Btu/h	<u>2.10</u>		
		$\geq 240,000$ Btu/h	<u>2.10</u>		

For SI: 1 British thermal unit per hour = 0.2931 W, °C = [(°F) – 32]/1.8, COP = (Btu/h × hp)/(2,550.7).

- a. Chapter 6 contains a complete specification of the referenced standards, which include test procedures, including the reference year version of the test procedure.
- b. This table is a replica of ASHRAE 90.1 Table 6.8.1-10 Floor-Mounted Air Conditioners and Condensing Units Serving Computer Rooms—Minimum Efficiency Requirements.

**TABLE C403.3.2(11)**  
**VAPOR-COMPRESSSION-BASED INDOOR POOL DEHUMIDIFIERS—MINIMUM EFFICIENCY REQUIREMENTS<sup>b</sup>**

EQUIPMENT TYPE	SUBCATEGORY OR RATING CONDITION	MINIMUM EFFICIENCY	TEST PROCEDURE <sup>a</sup>
Single package indoor (with or without economizer)	Rating Conditions: A or C	<u>3.5 MRE</u>	AHRI 910
Single package indoor water cooled (with or without economizer)	Rating Conditions: A, B or C	<u>3.5 MRE</u>	

<u>Single package indoor air cooled (with or without economizer)</u>	<u>Rating Conditions: A, B or C</u>	<u>3.5 MRE</u>	
<u>Split system indoor air cooled (with or without economizer)</u>	<u>Rating Conditions: A, B or C</u>	<u>3.5 MRE</u>	

- a. Chapter 6 contains a complete specification of the referenced standards, which include test procedures, including the reference year version of the test procedure.
- b. This table is a replica of ASHRAE 90.1 Table 6.8.1-12 Vapor-Compression-Based Indoor Pool Dehumidifiers—Minimum Efficiency Requirements.

**TABLE C403.3.2(12)**  
**ELECTRICALLY OPERATED DX-DOAS UNITS, SINGLE-PACKAGE AND REMOTE CONDENSER, WITHOUT ENERGY RECOVERY—MINIMUM EFFICIENCY REQUIREMENTS<sup>b</sup>**

<u>EQUIPMENT TYPE</u>	<u>SUBCATEGORY OR RATING CONDITION</u>	<u>MINIMUM EFFICIENCY</u>	<u>TEST PROCEDURE<sup>a</sup></u>
<u>Air cooled (dehumidification mode)</u>	=	<u>4.0 ISMRE</u>	<u>AHRI 920</u>
<u>Air-source heat pumps (dehumidification mode)</u>	=	<u>4.0 ISMRE</u>	<u>AHRI 920</u>
<u>Water cooled (dehumidification mode)</u>	<u>Cooling tower condenser water</u>	<u>4.9 ISMRE</u>	<u>AHRI 920</u>
	<u>Chilled water</u>	<u>6.0 ISMRE</u>	
<u>Air-source heat pump (heating mode)</u>	=	<u>2.7 IS COP</u>	<u>AHRI 920</u>
<u>Water-source heat pump (dehumidification mode)</u>	<u>Ground source, closed loop</u>	<u>4.8 ISMRE</u>	<u>AHRI 920</u>
	<u>Ground-water source</u>	<u>5.0 ISMRE</u>	
	<u>Water source</u>	<u>4.0 ISMRE</u>	
<u>Water-source heat pump (heating mode)</u>	<u>Ground source, closed loop</u>	<u>2.0 IS COP</u>	<u>AHRI 920</u>
	<u>Ground-water source</u>	<u>3.2 IS COP</u>	
	<u>Water source</u>	<u>3.5 IS COP</u>	

- a. Chapter 6 contains a complete specification of the referenced standards, which include test procedures, including the reference year version of the test procedure.
- b. This table is a replica of ASHRAE 90.1 Table 6.8.1-13 Electrically Operated DX-DOAS Units, Single-Package and Remote Condenser, without Energy Recovery—Minimum Efficiency Requirements.

**TABLE C403.3.2(13)**  
**ELECTRICALLY OPERATED DX-DOAS UNITS, SINGLE-PACKAGE AND REMOTE CONDENSER, WITH ENERGY RECOVERY—MINIMUM EFFICIENCY REQUIREMENTS<sup>b</sup>**

<u>EQUIPMENT TYPE</u>	<u>SUBCATEGORY OR RATING CONDITION</u>	<u>MINIMUM EFFICIENCY</u>	<u>TEST PROCEDURE<sup>a</sup></u>
<u>Air cooled (dehumidification mode)</u>	=	<u>5.2 ISMRE</u>	<u>AHRI 920</u>
<u>Air-source heat pumps (dehumidification mode)</u>	=	<u>5.2 ISMRE</u>	<u>AHRI 920</u>
<u>Water cooled (dehumidification mode)</u>	<u>Cooling tower condenser water</u>	<u>5.3 ISMRE</u>	<u>AHRI 920</u>
	<u>Chilled water</u>	<u>6.6 ISMRE</u>	
<u>Air-source heat pump (heating mode)</u>	=	<u>3.3 IS COP</u>	<u>AHRI 920</u>
<u>Water-source heat pump (dehumidification mode)</u>	<u>Ground source, closed loop</u>	<u>5.2 ISMRE</u>	<u>AHRI 920</u>
	<u>Ground-water source</u>	<u>5.8 ISMRE</u>	
	<u>Water source</u>	<u>4.8 ISMRE</u>	
<u>Water-source heat pump (heating mode)</u>	<u>Ground source, closed loop</u>	<u>3.8 IS COP</u>	<u>AHRI 920</u>



	<u>Ground-water source</u>	<u>4.0 IS COP</u>
	<u>Water source</u>	<u>4.8 IS COP</u>

- a. Chapter 6 contains a complete specification of the referenced standards, which include test procedures, including the reference year version of the test procedure.
- b. This table is a replica of ASHRAE 90.1 Table 6.8.1-14 Electrically Operated DX-DOAS Units, Single-Package and Remote Condenser, with Energy Recovery—Minimum Efficiency Requirements.

**TABLE C403.3.2(14)**  
**ELECTRICALLY OPERATED WATER-SOURCE HEAT PUMPS—MINIMUM EFFICIENCY REQUIREMENTS<sup>c</sup>**

<u>EQUIPMENT TYPE</u>	<u>SIZE CATEGORY<sup>b</sup></u>	<u>HEATING SECTION TYPE</u>	<u>SUBCATEGORY OR RATING CONDITION</u>	<u>MINIMUM EFFICIENCY</u>	<u>TEST PROCEDURE<sup>a</sup></u>
<u>Water-to-air, water loop (cooling mode)</u>	<u>&lt; 17,000 Btu/h</u>	<u>All</u>	<u>86°F entering water</u>	<u>12.2 EER</u>	<u>ISO 13256-1</u>
	<u>≥ 17,000 Btu/h and &lt; 65,000 Btu/h</u>			<u>13.0 EER</u>	
	<u>≥ 65,000 Btu/h and &lt; 135,000 Btu/h</u>			<u>13.0 EER</u>	
<u>Water-to-air, ground water (cooling mode)</u>	<u>&lt; 135,000 Btu/h</u>	<u>All</u>	<u>59°F entering water</u>	<u>18.0 EER</u>	<u>ISO 13256-1</u>
<u>Brine-to-air, ground loop (cooling mode)</u>	<u>&lt; 135,000 Btu/h</u>	<u>All</u>	<u>77°F entering water</u>	<u>14.1 EER</u>	<u>ISO 13256-1</u>
<u>Water-to-water, water loop (cooling mode)</u>	<u>&lt; 135,000 Btu/h</u>	<u>All</u>	<u>86°F entering water</u>	<u>10.6 EER</u>	<u>ISO 13256-2</u>
<u>Water-to-water, ground water (cooling mode)</u>	<u>&lt; 135,000 Btu/h</u>	<u>All</u>	<u>59°F entering water</u>	<u>16.3 EER</u>	<u>ISO 13256-2</u>
<u>Brine-to-water, ground loop (cooling mode)</u>	<u>&lt; 135,000 Btu/h</u>	<u>All</u>	<u>77°F entering water</u>	<u>12.1 EER</u>	<u>ISO 13256-2</u>
<u>Water-to-water, water loop (heating mode)</u>	<u>&lt; 135,000 Btu/h (cooling capacity)</u>	<u>=</u>	<u>68°F entering water</u>	<u>4.3 COP<sub>H</sub></u>	<u>ISO 13256-1</u>
<u>Water-to-air, ground water (heating mode)</u>	<u>&lt; 135,000 Btu/h (cooling capacity)</u>	<u>=</u>	<u>50°F entering water</u>	<u>3.7 COP<sub>H</sub></u>	<u>ISO 13256-1</u>
<u>Brine-to-air, ground loop (heating mode)</u>	<u>&lt; 135,000 Btu/h (cooling capacity)</u>	<u>=</u>	<u>32°F entering water</u>	<u>3.2 COP<sub>H</sub></u>	<u>ISO 13256-1</u>
<u>Water-to-water, water loop (heating mode)</u>	<u>&lt; 135,000 Btu/h (cooling capacity)</u>	<u>=</u>	<u>68°F entering water</u>	<u>3.7 COP<sub>H</sub></u>	<u>ISO 13256-1</u>
<u>Water-to-water, ground water (heating mode)</u>	<u>&lt; 135,000 Btu/h (cooling capacity)</u>	<u>=</u>	<u>50°F entering water</u>	<u>3.1 COP<sub>H</sub></u>	<u>ISO 13256-2</u>
<u>Brine-to-water, ground loop (heating mode)</u>	<u>&lt; 135,000 Btu/h (cooling capacity)</u>	<u>=</u>	<u>32°F entering water</u>	<u>2.5 COP<sub>H</sub></u>	<u>ISO 13256-2</u>

For SI: 1 British thermal unit per hour = 0.2931 W, °C = [(°F) – 32]/1.8.

- a. Chapter 6 contains a complete specification of the referenced standards, which include test procedures, including the reference year version of the test procedure.
- b. Single-phase, US air-cooled heat pumps less than 19 kW are regulated as consumer products by DOE 10 CFR 430. SCOPC, SCOP2C, SCOPH and SCOP2H values for single-phase products are set by the USDOE.
- c. This table is a replica of ASHRAE 90.1 Table 6.8.1-15 Electrically Operated Water-Source Heat Pumps—Minimum Efficiency Requirements.

**TABLE C403.3.2(15)**  
**HEAT-PUMP AND HEAT RECOVERY CHILLER PACKAGES—MINIMUM EFFICIENCY REQUIREMENTS<sup>9</sup>**

HEATING OPERATION													
EQUIPMENT TYPE	SIZE CATEGORY Y, ton <sub>R</sub>	COOLING-ONLY OPERATION COOLING EFFICIENCY <sup>c</sup> AIR-SOURCE EER (FL/IPLV), Btu/W × h WATER-SOURCE POWER INPUT PER CAPACITY (FL/IPLV), kW/ton <sub>R</sub>		HEATING SOURCE CONDITIONS (entering/leaving water) OR OAT (db/wb), °F	HEAT-PUMP HEATING FULL-LOAD EFFICIENCY (COP <sub>H</sub> ) <sup>b</sup> , W/W				HEAT RECOVERY CHILLER FULL-LOAD EFFICIENCY (COP <sub>HR</sub> ) <sup>c,d</sup> , W/W SIMULTANEOUS COOLING AND HEATING FULL-LOAD EFFICIENCY (COP <sub>SHC</sub> ) <sup>c</sup> , W/W				Test Procedure <sup>a</sup>
		Path A	Path B		Leaving Heating Water Temperature				Leaving Heating Water Temperature				
					Low	Medium	High	Boost	Low	Medium	High	Boost	
		105°F	120°F		140°F	140°F	105°F	120°F	140°F	140°F			
Air source	All sizes	≥ 9.595 FL ≥ 13.02 IPLV.IP	≥ 9.215 FL ≥ 15.01 IPLV.IP	47 db 43 wb <sup>c</sup>	≥ 3.290	≥ 2.770	≥ 2.310	NA	NA	NA	NA	NA	AHRI 550/590
		≥ 9.595 FL ≥ 13.30 IPLV.IP	≥ 9.215 FL ≥ 15.30 IPLV.IP	17 db 15 wb <sup>c</sup>	≥ 2.230	≥ 1.950	≥ 1.630	NA	NA	NA	NA	NA	
Water-source electrically operated positive displacement	< 75	≤ 0.7885 FL ≤ 0.6316 IPLV.IP	≤ 0.7875 FL ≤ 0.5145 IPLV.IP	54/44 <sup>f</sup>	≥ 4.640	≥ 3.680	≥ 2.680	NA	≥ 8.330	≥ 6.410	≥ 4.420	NA	AHRI 550/590
		75/65 <sup>f</sup>	NA	NA	NA	≥ 3.550	NA	NA	NA	6.150			
	≥ 75 and < 150	≤ 0.7579 FL ≤ 0.5895 IPLV.IP	≤ 0.7140 FL ≤ 0.4620 IPLV.IP	54/44 <sup>f</sup>	≥ 4.640	≥ 3.680	≥ 2.680	NA	≥ 8.330	≥ 6.410	≥ 4.420	NA	
		75/65 <sup>f</sup>	NA	NA	NA	≥ 3.550	NA	NA	NA	6.150			
	≥ 150 and < 300	≤ 0.6947 FL ≤ 0.5684 IPLV.IP	≤ 0.7140 FL ≤ 0.4620 IPLV.IP	54/44 <sup>f</sup>	≥ 4.640	≥ 3.680	≥ 2.680	NA	≥ 8.330	≥ 6.410	≥ 4.420	NA	
		75/65 <sup>f</sup>	NA	NA	NA	≥ 3.550	NA	NA	NA	6.150			
	≥ 300 and < 600	≤ 0.6421 FL ≤ 0.5474 IPLV.IP	≤ 0.6563 FL ≤ 0.4305 IPLV.IP	54/44 <sup>f</sup>	≥ 4.930	≥ 3.960	≥ 2.970	NA	≥ 8.900	≥ 6.980	≥ 5.000	NA	
		75/65 <sup>f</sup>	NA	NA	NA	≥ 3.900	NA	NA	NA	6.850			
	≥ 600	≤ 0.5895 FL ≤ 0.5263 IPLV.IP	≤ 0.6143 FL ≤ 0.3990 IPLV.IP	54/44 <sup>f</sup>	≥ 4.930	≥ 3.960	≥ 2.970	NA	≥ 8.900	≥ 6.980	≥ 5.000	NA	
		75/65 <sup>f</sup>	NA	NA	NA	≥ 3.900	NA	NA	NA	6.850			
Water-source electrically operated centrifugal	< 75	≤ 0.6421 FL ≤ 0.5789 IPLV.IP	≤ 0.7316 FL ≤ 0.4632 IPLV.IP	54/44 <sup>f</sup>	≥ 4.640	≥ 3.680	≥ 2.680	NA	≥ 8.330	≥ 6.410	≥ 4.420	NA	AHRI 550/590
		75/65 <sup>f</sup>	NA	NA	NA	≥ 3.550	NA	NA	NA	≥ 6.150			
	≥ 75 and < 150	≤ 0.5895 FL ≤ 0.5474 IPLV.IP	≤ 0.6684 FL ≤ 0.4211 IPLV.IP	54/44 <sup>f</sup>	≥ 4.640	≥ 3.680	≥ 2.680	NA	≥ 8.330	≥ 6.410	≥ 4.420	NA	
		75/65 <sup>f</sup>	NA	NA	NA	≥ 3.550	NA	NA	NA	≥ 6.150			
	≥ 150 and < 300	≤ 0.5895 FL ≤ 0.5263 IPLV.IP	≤ 0.6263 FL ≤ 0.4105 IPLV.IP	54/44 <sup>f</sup>	≥ 4.640	≥ 3.680	≥ 2.680	NA	≥ 8.330	≥ 6.410	≥ 4.420	NA	
		75/65 <sup>f</sup>	NA	NA	NA	≥ 3.550	NA	NA	NA	≥ 6.150			
	≥ 300 and < 600	≤ 0.5895 FL ≤ 0.5263 IPLV.IP	≤ 0.6158 FL ≤ 0.4000 IPLV.IP	54/44 <sup>f</sup>	≥ 4.930	≥ 3.960	≥ 2.970	NA	≥ 8.900	≥ 6.980	≥ 5.000	NA	
		75/65 <sup>f</sup>	NA	NA	NA	≥ 3.900	NA	NA	NA	≥ 6.850			
	≥ 600	≤ 0.5895 FL ≤ 0.5263 IPLV.IP	≤ 0.6158 FL ≤ 0.4000 IPLV.IP	54/44 <sup>f</sup>	≥ 4.930	≥ 3.960	≥ 2.970	NA	≥ 8.900	≥ 6.980	≥ 5.000	NA	
		75/65 <sup>f</sup>	NA	NA	NA	≥ 3.900	NA	NA	NA	≥ 6.850			

For SI: °C = [(°F) - 32]/1.8.

- a. Chapter 6 contains a complete specification of the referenced standards, which include test procedures, including the reference year version of the test procedure.

- b. Cooling-only rating conditions are standard rating conditions defined in AHRI 550/590, Table 1.
- c. Heating full-load rating conditions are at rating conditions defined in AHRI 550/590, Table 1.
- d. For water-cooled heat recovery chillers that have capabilities for heat rejection to a heat recovery condenser and a tower condenser, the COP<sub>HR</sub> applies to operation at full load with 100 percent heat recovery (no tower rejection). Units that only have capabilities for partial heat recovery shall meet the requirements of Table C403.3.2(3).
- e. Outdoor air entering dry-bulb (db) temperature and wet-bulb (wb) temperature.
- f. Source-water entering and leaving water temperature.
- g. This table is a replica of ASHRAE 90.1 Table 6.8.1-16 Heat-Pump and Heat Recovery Chiller Packages—Minimum Efficiency Requirements.

**TABLE C403.3.2(16)**  
**CEILING-MOUNTED COMPUTER-ROOM AIR CONDITIONERS—MINIMUM EFFICIENCY REQUIREMENTS<sup>b</sup>**

<u>EQUIPMENT TYPE</u>	<u>STANDARD MODEL</u>	<u>NET SENSIBLE COOLING CAPACITY</u>	<u>MINIMUM NET SENSIBLE COP</u>	<u>RATING CONDITIONS RETURN AIR (dry bulb/dew point)</u>	<u>TEST PROCEDURE<sup>a</sup></u>
<u>Air cooled with free air discharge condenser</u>	<u>Ducted</u>	<u>&lt; 29,000 Btu/h</u>	<u>2.05</u>	<u>75°F/52°F (Class 1)</u>	<u>AHRI 1360</u>
		<u>≥ 29,000 Btu/h and &lt; 65,000 Btu/h</u>	<u>2.02</u>		
		<u>≥ 65,000 Btu/h</u>	<u>1.92</u>		
	<u>Nonducted</u>	<u>&lt; 29,000 Btu/h</u>	<u>2.08</u>		
		<u>≥ 29,000 Btu/h and &lt; 65,000 Btu/h</u>	<u>2.05</u>		
		<u>≥ 65,000 Btu/h</u>	<u>1.94</u>		
<u>Air cooled with free air discharge condenser with fluid economizer</u>	<u>Ducted</u>	<u>&lt; 29,000 Btu/h</u>	<u>2.01</u>	<u>75°F/52°F (Class 1)</u>	<u>AHRI 1360</u>
		<u>≥ 29,000 Btu/h and &lt; 65,000 Btu/h</u>	<u>1.97</u>		
		<u>≥ 65,000 Btu/h</u>	<u>1.87</u>		
	<u>Nonducted</u>	<u>&lt; 29,000 Btu/h</u>	<u>2.04</u>		
		<u>≥ 29,000 Btu/h and &lt; 65,000 Btu/h</u>	<u>2.00</u>		
		<u>≥ 65,000 Btu/h</u>	<u>1.89</u>		
<u>Air cooled with ducted condenser</u>	<u>Ducted</u>	<u>&lt; 29,000 Btu/h</u>	<u>1.86</u>	<u>75°F/52°F (Class 1)</u>	<u>AHRI 1360</u>
		<u>≥ 29,000 Btu/h and &lt; 65,000 Btu/h</u>	<u>1.83</u>		
		<u>≥ 65,000 Btu/h</u>	<u>1.73</u>		
	<u>Nonducted</u>	<u>&lt; 29,000 Btu/h</u>	<u>1.89</u>		
		<u>≥ 29,000 Btu/h and &lt; 65,000 Btu/h</u>	<u>1.86</u>		
		<u>≥ 65,000 Btu/h</u>	<u>1.75</u>		
<u>Air cooled with fluid economizer and ducted condenser</u>	<u>Ducted</u>	<u>&lt; 29,000 Btu/h</u>	<u>1.82</u>	<u>75°F/52°F (Class 1)</u>	<u>AHRI 1360</u>
		<u>≥ 29,000 Btu/h and &lt; 65,000 Btu/h</u>	<u>1.78</u>		
		<u>≥ 65,000 Btu/h</u>	<u>1.68</u>		
	<u>Nonducted</u>	<u>&lt; 29,000 Btu/h</u>	<u>1.85</u>		

		<u>&gt; 29,000 Btu/h and &lt; 65,000 Btu/h</u>	<u>1.81</u>		
		<u>&gt; 65,000 Btu/h</u>	<u>1.70</u>		
<u>Water cooled</u>	<u>Ducted</u>	<u>&lt; 29,000 Btu/h</u>	<u>2.38</u>	<u>75°F/52°F (Class 1)</u>	<u>AHRI 1360</u>
		<u>&gt; 29,000 Btu/h and &lt; 65,000 Btu/h</u>	<u>2.28</u>		
		<u>&gt; 65,000 Btu/h</u>	<u>2.18</u>		
	<u>Nonducted</u>	<u>&lt; 29,000 Btu/h</u>	<u>2.41</u>		
		<u>&gt; 29,000 Btu/h and &lt; 65,000 Btu/h</u>	<u>2.31</u>		
		<u>&gt; 65,000 Btu/h</u>	<u>2.20</u>		

<u>EQUIPMENT TYPE</u>	<u>STANDARD MODEL</u>	<u>NET SENSIBLE COOLING CAPACITY</u>	<u>MINIMUM NET SENSIBLE COP</u>	<u>RATING CONDITIONS RETURN AIR (dry bulb/dew point)</u>	<u>TEST PROCEDURE<sup>a</sup></u>
<u>Water cooled with fluid economizer</u>	<u>Ducted</u>	<u>&lt; 29,000 Btu/h</u>	<u>2.33</u>	<u>75°F/52°F (Class 1)</u>	<u>AHRI 1360</u>
		<u>&gt; 29,000 Btu/h and &lt; 65,000 Btu/h</u>	<u>2.23</u>		
		<u>&gt; 65,000 Btu/h</u>	<u>2.13</u>		
	<u>Nonducted</u>	<u>&lt; 29,000 Btu/h</u>	<u>2.36</u>		
		<u>&gt; 29,000 Btu/h and &lt; 65,000 Btu/h</u>	<u>2.26</u>		
		<u>&gt; 65,000 Btu/h</u>	<u>2.16</u>		
<u>Glycol cooled</u>	<u>Ducted</u>	<u>&lt; 29,000 Btu/h</u>	<u>1.97</u>	<u>75°F/52°F (Class 1)</u>	<u>AHRI 1360</u>
		<u>&gt; 29,000 Btu/h and &lt; 65,000 Btu/h</u>	<u>1.93</u>		
		<u>&gt; 65,000 Btu/h</u>	<u>1.78</u>		
	<u>Nonducted</u>	<u>&lt; 29,000 Btu/h</u>	<u>2.00</u>		
		<u>&gt; 29,000 Btu/h and &lt; 65,000 Btu/h</u>	<u>1.98</u>		
		<u>&gt; 65,000 Btu/h</u>	<u>1.81</u>		
<u>Glycol cooled with fluid economizer</u>	<u>Ducted</u>	<u>&lt; 29,000 Btu/h</u>	<u>1.92</u>	<u>75°F/52°F (Class 1)</u>	<u>AHRI 1360</u>
		<u>&gt; 29,000 Btu/h and &lt; 65,000 Btu/h</u>	<u>1.88</u>		
		<u>&gt; 65,000 Btu/h</u>	<u>1.73</u>		
	<u>Nonducted</u>	<u>&lt; 29,000 Btu/h</u>	<u>1.95</u>		
		<u>&gt; 29,000 Btu/h and &lt; 65,000 Btu/h</u>	<u>1.93</u>		
		<u>&gt; 65,000 Btu/h</u>	<u>1.76</u>		

For SI: 1 British thermal unit per hour = 0.2931 W, °C = [(°F) - 32]/1.8, COP = (Btu/h × hp)/(2,550.7).

- a. Chapter 6 contains a complete specification of the referenced standards, which include test procedures, including the reference year version of the test procedure.
- b. This is a replica of ASHRAE 90.1 Table 6.8.1-17 Ceiling-Mounted Computer-Room Air Conditioners—Minimum Efficiency Requirements.

~~€403.2.3.1~~**C403.3.2.1 Water-cooled centrifugal chilling packages.** Equipment not designed for operation at AHRI Standard 550/590 test conditions of 44°F (7°C) leaving chilled water temperature and 2.4 gpm/ton evaporator fluid flow and 85°F (29°C) entering condenser water temperature with 3 gpm/ton (0.054 l/s · kW) condenser water flow shall have maximum full-load kW/ton (FL) and part load ratings requirements adjusted using Equations 4-6 and 4-7. 44.00°F leaving and 54.00°F entering chilled-fluid temperatures, and with 85.00°F entering and 94.30°F leaving condenser-fluid temperatures, shall have maximum full-load kW/ton (FL) and part-load rating requirements adjusted using the following equations:

$$FL_{adj} = FL/K_{adj} \quad \text{(Equation 4-6)}$$

$$PLV_{adj} = IPLV \cdot IP/K_{adj} \quad \text{(Equation 4-7)}$$

where:

$$K_{adj} = A \times B$$

~~FL~~ = Full-load kW/ton value as specified in Table C403.2.3(7). ~~from Table C403.3.2(3).~~

~~FL<sub>adj</sub>~~ = Maximum full-load kW/ton rating, adjusted for nonstandard conditions.

~~IPLV~~ = Value as specified in Table C403.2.3(7). ~~IPLV · IP~~ = ~~IPLV · IP~~ value from Table C403.3.2(3).

~~PLV<sub>adj</sub>~~ = Maximum ~~NPLV~~ rating, adjusted for nonstandard conditions.

$$A = 0.00000014592 \times (LIFT)^4 - 0.0000346496 \times (LIFT)^3 + 0.00314196 \times (LIFT)^2 - 0.147199 \times (LIFT) + 3.93023.93073$$

$$B = 0.0015 \times L_{vg}E_{vap} + 0.934$$

$$LIFT = L_{vg}Cond - L_{vg}E_{vap}$$

$L_{vg}Cond$  = Full-load condenser leaving fluid temperature (°F).

$L_{vg}E_{vap}$  = Full-load evaporator leaving temperature (°F).

The  $FL_{adj}$  and  $PLV_{adj}$  values are applicable only for centrifugal chillers meeting all of the following full-load design ranges:

1. ~~Minimum evaporator leaving temperature: 36°F.~~

2. ~~Maximum condenser leaving temperature: 115°F.~~

3. ~~20.00°F ≤ LIFT ≤ 80.00°F.~~

• ~~36.00°F ≤  $L_{vg}E_{vap}$  ≤ 60.00°F~~

•  ~~$L_{vg}Cond$  ≤ 115.00°F~~

• ~~20.00°F < LIFT < 80.00°F~~

Manufacturers shall calculate the  $FL_{adj}$  and  $PLV_{adj}$  before determining whether to label the chiller. Centrifugal chillers designed to operate outside of these ranges are not covered by this code.

~~€403.2.3.2~~**C403.3.2.2 Positive displacement (air- and water-cooled) chilling packages.** Equipment with a leaving fluid temperature higher than 32°F (0°C) and water-cooled positive displacement chilling packages with a condenser leaving fluid temperature below 115°F (46°C) shall meet the requirements of the tables in Section ~~€403.2.3(7)~~C403.3.2 when tested or certified with water at standard rating conditions, in accordance with the referenced test procedure.

~~€403.4.6~~**C403.3.3 Hot gas bypass limitation.** Cooling systems shall not use hot gas bypass or other evaporator pressure control systems unless the system is designed with multiple steps of unloading or continuous capacity modulation. The capacity of the hot gas bypass shall be limited as indicated in Table ~~€403.4.6,~~C403.3.3, as limited by Section ~~€403.3.1,~~C403.5.1.

**Exception:** Unitary packaged systems with nominal cooling capacities of 7.5 tons or less (approximately 90 kBTU/h or 26.4 kW).

**TABLE ~~C403.4.2.5~~C403.3.3**  
**MAXIMUM HOT GAS BYPASS CAPACITY**

RATED CAPACITY	MAXIMUM HOT GAS BYPASS CAPACITY (% of total capacity)
≤ 240,000 Btu/h	50
> 240,000 Btu/h	25

For SI: 1 British thermal unit per hour = 0.2931 W.

**~~C403.4.2.5~~C403.3.4 Boiler turndown.** Boiler systems with design input of greater than 1,000,000 Btu/h (293 kW) shall comply with the turndown ratio specified in Table ~~C403.4.2.5~~C403.3.4.

The system turndown requirement shall be met through the use of multiple single-input boilers, one or more *modulating boilers* or a combination of single-input and *modulating boilers*.

**TABLE ~~C403.4.2.5~~C403.3.4**  
**BOILER TURNDOWN**

BOILER SYSTEM DESIGN INPUT (Btu/h)	MINIMUM TURNDOWN RATIO
≥ 1,000,000 and ≤ 5,000,000	3 to 1
> 5,000,000 and ≤ 10,000,000	4 to 1
> 10,000,000	5 to 1

**~~C403.2.4 HVAC system controls.~~C403.4 Heating and cooling system controls.** Each heating and cooling system shall be provided with thermostatic controls as specified in Section ~~C403.2.4.1, C403.2.4.1.3, C403.2.4.2, C403.2.4.3, C403.3.1, C403.4, C403.4.1 or C403.4.4~~ in accordance with Sections C403.4.1 through C403.4.5.

**~~C403.2.4.1~~C403.4.1 Thermostatic controls.** The supply of heating and cooling energy to each *zone* shall be controlled by individual thermostatic controls capable of responding to temperature within the *zone*. Where humidification or dehumidification or both is provided, at least not fewer than one humidity control device shall be provided for each humidity control system.

**Exception:** Independent perimeter systems that are designed to offset only building envelope heat losses, gains or both serving one or more perimeter *zones* also served by an interior system ~~provided~~ provided that both of the following conditions are met:

1. The perimeter system includes at least not fewer than one thermostatic control *zone* for each building exposure having exterior walls facing only one orientation (within ±45 degrees) (0.8 rad) for more than 50 contiguous feet (~~15 240 mm~~); and (15 240 mm).
2. The perimeter system heating and cooling supply is controlled by thermostats located within the *zones* served by the system.

**~~C403.2.4.1.1~~C403.4.1.1 Heat pump supplementary heat.** Heat pumps having supplementary electric resistance heat shall have controls that, except during defrost, prevent supplementary heat operation where the heat pump can provide the heating load that limit supplemental heat operation to only those times when one of the following applies:

1. The vapor compression cycle cannot provide the necessary heating energy to satisfy the thermostat setting.
2. The heat pump is operating in defrost mode.
3. The vapor compression cycle malfunctions.

#### 4. The thermostat malfunctions.

~~In systems with a cooling capacity of less than 65,000 Btuh, a heat strip outdoor temperature lock-out shall be provided to prevent supplemental heat operation in response to the thermostat being changed to a warmer setting. The lockout shall be set no lower than 35°F and no higher than 40°F.~~

~~C403.2.4.1.2~~**C403.4.1.2 Deadband.** Where used to control both heating and cooling, *zone* thermostatic controls shall be ~~capable of providing~~configured to provide a temperature range or deadband of ~~at least~~not less than 5°F (2.8°C) within which the supply of heating and cooling energy to the *zone* is shut off or reduced to a minimum.

#### **Exceptions:**

1. Thermostats requiring manual changeover between heating and cooling modes.
2. Occupancies or applications requiring precision in indoor temperature ~~control~~control as approved by the code official.

~~C403.2.4.1.3~~**C403.4.1.3 Setpoint overlap restriction.** Where a *zone* has a separate heating and a separate cooling thermostatic control located within the *zone*, a limit switch, mechanical stop or direct digital control system with software programming shall be ~~provided with the capability~~configured to prevent the heating setpoint from exceeding the cooling setpoint and to maintain a deadband in accordance with Section ~~C403.2.4.1.2~~C403.4.1.2.

**C403.4.1.4 Heated or cooled vestibules.** The heating system for heated vestibules and air curtains with integral heating shall be provided with controls configured to shut off the source of heating when the outdoor air temperature is greater than 45°F (7°C). Vestibule heating and cooling systems shall be controlled by a thermostat located in the vestibule configured to limit heating to a temperature not greater than 60°F (16°C) and cooling to a temperature not less than 85°F (29°C).

**Exception:** Control of heating or cooling provided by site-recovered energy or transfer air that would otherwise be exhausted.

~~C403.2.5~~**C403.4.1.5 Hot water boiler outdoor temperature setback control.** Hot water boilers that supply heat to the building through one- or two-pipe heating systems shall have an outdoor setback control that lowers the boiler water temperature based on the outdoor temperature.

~~C403.2.4.2~~**C403.4.2 Off-hour controls.** Each *zone* shall be provided with thermostatic setback controls that are controlled by either an automatic time clock or programmable control system.

#### **Exceptions:**

1. *Zones* that will be operated continuously.
2. *Zones* with a full HVAC load demand not exceeding 6,800 Btu/h (2 kW) and having a ~~readily accessible~~ manual shutoff ~~switch~~switch located with ready access.
3. ~~HVAC systems serving hotel/motel guest rooms or other residential units complying with Section C403.2.2 requirements.~~

~~C403.2.4.2.1~~**C403.4.2.1 Thermostatic setback capabilities.**~~setback.~~ Thermostatic setback controls shall ~~have the capability to be configured~~ to set back or temporarily operate the system to maintain zone temperatures down to 55°F (13°C) or up to 85°F (29°C).

~~C403.2.4.2.2~~**C403.4.2.2 Automatic setback and shutdown capabilities.**~~shutdown.~~ Automatic time clock or programmable controls shall be capable of starting and stopping the system for seven different daily schedules per week and retaining their programming and time setting during a loss of power for ~~at least~~not fewer than 10 hours. Additionally, the controls shall have a manual override that allows temporary operation of the system for up to 2 hours; a manually operated timer ~~capable of being adjusted~~configured to operate the system for up to 2 hours; or an occupancy sensor.

~~C403.2.4.2.3~~**C403.4.2.3 Automatic start capabilities and stop.** Automatic start controls shall be provided for each HVAC system ~~provided with setback controls and direct digital control (DDC) system.~~ The automatic start controls shall be ~~capable of configured to~~ automatically adjust the daily start time of the HVAC system in order to bring each space to the desired occupied temperature immediately prior to scheduled occupancy. Automatic stop controls shall be provided for each HVAC system with direct digital control of individual zones. The automatic stop controls shall be configured to reduce the HVAC system's heating temperature setpoint and increase the cooling temperature setpoint by not less than 2°F (-

16.6°C) before scheduled unoccupied periods based on the thermal lag and acceptable drift in space temperature that is within comfort limits.

~~C403.2.11 Mechanical systems commissioning and completion requirements.~~ Mechanical systems shall be commissioned and completed in accordance with Section C408.2.

**C403.4 Hydronic and multiple zone HVAC systems controls and equipment. (Prescriptive).** Hydronic and multiple zone HVAC system controls and equipment shall comply with this section.

~~C403.4.2~~**C403.4.3 Hydronic systems controls.** The heating of fluids that have been previously mechanically cooled and the cooling of fluids that have been previously mechanically heated shall be limited in accordance with Sections ~~C403.4.2.1-C403.4.3.1~~ through ~~C403.4.2.3-C403.4.3.3~~. Hydronic heating systems comprised of multiple-packaged boilers and designed to deliver conditioned water or steam into a common distribution system shall include automatic controls ~~capable of sequencing~~ configured to sequence operation of the boilers. Hydronic heating systems composed of a single boiler and greater than 500,000 Btu/h (146.5 kW) input design capacity shall include either a multistaged or modulating burner.

~~C403.4.2.1~~**C403.4.3.1 Three-pipe system.** Hydronic systems that use a common return system for both hot water and chilled water are prohibited.

~~C403.4.2.2~~**C403.4.3.2 Two-pipe changeover system.** Systems that use a common distribution system to supply both heated and chilled water shall be designed to allow a ~~dead band~~deadband between changeover from one mode to the other of not less than 15°F (8.3°C) outside air temperatures; be designed to and provided with controls that will allow operation in one mode for not less than 4 hours before changing over to the other mode; and be provided with controls that allow heating and cooling supply temperatures at the changeover point to be not more than 30°F (16.7°C) apart.

~~C403.4.2.3~~**C403.4.3.3 Hydronic (water loop) heat pump systems.** Hydronic heat pump systems shall comply with Sections ~~C403.4.2.3.1 through C403.4.2.3.2~~C403.4.3.3.1 through C403.4.3.3.3.

~~C403.4.2.3.1~~**C403.4.3.3.1 Temperature ~~dead band~~**deadband. Hydronic heat pumps connected to a common heat pump water loop with central devices for heat rejection and heat addition shall have controls that are configured to provide a heat pump water supply temperature ~~dead band~~deadband of not less than 20°F (11°C) between initiation of heat rejection and heat addition by the central devices.

**Exception:** Where a system loop temperature optimization controller is installed and can determine the most efficient operating temperature based on real-time conditions of demand and capacity, ~~dead bands~~deadbands of less than 20°F (11°C) shall be permitted.

~~C403.4.2.3.2~~**C403.4.3.3.2 Heat rejection.** Heat rejection equipment shall comply with Sections ~~C403.4.2.3.2.1 and C403.4.2.3.2.2~~. The following shall apply to hydronic water loop heat pump systems in Climate Zones 3 through 8:

~~C403.4.2.3.2.1~~**Climate zones 3 and 4.** For *Climate Zones 3 and 4*:

1. Where a closed-circuit cooling tower is used directly in the heat pump loop, either an automatic valve shall be installed to bypass ~~all but a minimal~~ the flow of water around the closed-circuit cooling tower, except for any flow necessary for freeze protection, or ~~lower leakage positive closure~~low-leakage positive-closure dampers shall be provided.
2. Where an open-circuit cooling tower is used directly in the heat pump loop, an automatic valve shall be installed to bypass all heat pump water flow around the open-circuit cooling tower.
3. Where an ~~open~~open-circuit or closed-circuit cooling tower is used in conjunction with a separate heat exchanger to isolate the open-circuit cooling tower from the heat pump loop, ~~then~~ heat loss shall be controlled by shutting down the circulation pump on the cooling tower loop.

**Exception:** Where it can be demonstrated that a heat pump system will be required to reject heat throughout the year.

~~C403.4.2.3.2.2~~**Climate zone 5.** For *Climate Zone 5*, where an ~~open or closed circuit cooling tower is used~~, a separate heat exchanger shall be provided to isolate the cooling tower from the heat pump loop, and heat loss shall be controlled by shutting down the circulation pump on the cooling tower loop and providing an automatic valve to stop the flow of fluid.

~~C403.4.2.3.3~~**C403.4.3.3.3 Two-position valve.** Each hydronic heat pump on the hydronic system having a total pump system power exceeding 10 hp (7.5 kW) shall have a two-position ~~valve~~automatic valve interlocked to shut off the water flow when the compressor is off.



~~C403.4.2.4~~**C403.4.4 Part-load controls.** Hydronic heating systems greater than or equal to 300,000 Btu/h (87.930 W)(87.9 kW) in design output capacity supplying heated or chilled water to comfort conditioning systems shall include controls that ~~have the capability to:~~ are configured to do all of the following:

- ~~1. Automatically reset the supply hot water temperatures using zone return water temperature, building return water temperature, or outside air temperature as an indicator of building heating or cooling demand. The temperature shall be capable of being reset by at least 25 percent of the design supply to return water temperature difference; or~~
- ~~2. Reduce system pump flow by at least 50 percent of design flow rate utilizing adjustable speed drive(s) on pump(s), or multiple staged pumps where at least one half of the total pump horsepower is capable of being automatically turned off or control valves designed to modulate or step down, and close, as a function of load, or other approved means.~~
1. Automatically reset the supply-water temperatures in response to varying building heating and cooling demand using coil valve position, zone-return water temperature, building-return water temperature or outside air temperature. The temperature shall be reset by not less than 25 percent of the design supply-to-return water temperature difference.
2. Automatically vary fluid flow for hydronic systems with a combined pump motor capacity of 2 hp (1.5 kW) or larger with three or more control valves or other devices by reducing the system design flow rate by not less than 50 percent or the maximum reduction allowed by the equipment manufacturer for proper operation of equipment by valves that modulate or step open and close, or pumps that modulate or turn on and off as a function of load.
3. Automatically vary pump flow on heating-water systems, chilled-water systems and heat rejection loops serving water-cooled unitary air conditioners as follows:
  - 3.1. Where pumps operate continuously or operate based on a time schedule, pumps with nominal output motor power of 2 hp or more shall have a variable speed drive.
  - 3.2. Where pumps have automatic direct digital control configured to operate pumps only when zone heating or cooling is required, a variable speed drive shall be provided for pumps with motors having the same or greater nominal output power indicated in Table C403.4.4 based on the climate zone and system served.
4. Where a variable speed drive is required by Item 3 of this section, pump motor power input shall be not more than 30 percent of design wattage at 50 percent of the design water flow. Pump flow shall be controlled to maintain one control valve nearly wide open or to satisfy the minimum differential pressure.

**Exceptions:**

1. Supply-water temperature reset is not required for chilled-water systems supplied by off-site district chilled water or chilled water from ice storage systems.
2. Variable pump flow is not required on dedicated coil circulation pumps where needed for freeze protection.
3. Variable pump flow is not required on dedicated equipment circulation pumps where configured in primary/secondary design to provide the minimum flow requirements of the equipment manufacturer for proper operation of equipment.
4. Variable speed drives are not required on heating water pumps where more than 50 percent of annual heat is generated by an electric boiler.

**TABLE C403.4.4  
VARIABLE SPEED DRIVE (VSD) REQUIREMENTS FOR DEMAND-CONTROLLED PUMPS**

<u>CHILLED WATER AND HEAT REJECTION LOOP PUMPS IN THESE CLIMATE ZONES</u>	<u>HEATING WATER PUMPS IN THESE CLIMATE ZONES</u>	<u>VSD REQUIRED FOR MOTORS WITH RATED OUTPUT OF:</u>
<u>3A, 4A,</u>		<u>≥ 5 hp</u>
<u>5A</u>	<u>5A</u>	<u>≥ 7.5 hp</u>
<u>—</u>	<u>4A</u>	<u>≥ 10 hp</u>
<u>—</u>	<u>3A</u>	<u>≥ 25 hp</u>

For SI: 1 hp = 0.746 kW.

~~C403.4.2.6~~**C403.4.5 Pump isolation.** Chilled water plants including more than one chiller ~~have the capability~~ shall be capable of and configured to reduce flow automatically through the chiller plant when a chiller is shut down. Chillers piped in series for the purpose of increased temperature differential shall be considered as one chiller.

Boiler ~~plants systems~~ including more than one boiler shall ~~have the capability~~ be capable of and configured to reduce flow automatically through the boiler ~~plant system~~ when a boiler is shut down.

~~C403.3~~**C403.5 Economizers (Prescriptive)-Economizers.** Economizers shall comply with Sections ~~C403.3.4~~C403.5.1 through ~~C403.3.4~~C403.5.5.

An air or water economizer shall be provided for the following cooling systems:

1. Chilled water systems with a total cooling capacity, less cooling capacity provided with air economizers, as specified in Table C403.5(1).
2. Individual fan systems with cooling capacity greater than 60,000 Btu/h in buildings having other than a Group R occupancy.  
The total supply capacity of all fan cooling units not provided with economizers shall not exceed 20 percent of the total supply capacity of all fan cooling units in the building or 300,000 Btu/h (88 kW), whichever is greater.
3. Individual fan systems with cooling capacity greater than or equal to 270,000 Btu/h (79.1 kW) in buildings having a Group R occupancy.  
The total supply capacity of all fan cooling units not provided with economizers shall not exceed 20 percent of the total supply capacity of all fan cooling units in the building or 1,500,000 Btu/h (440 kW), whichever is greater.

**Exceptions:** Economizers are not required for the ~~systems listed below~~ following systems.

1. ~~Deleted~~ Individual fan systems not served by chilled water for buildings located in *Climate Zones* 0A, 0B, 1A and 1B.
2. ~~Where individual fan cooling units have a capacity of less than 65,000 Btu/h (19.0 kW).~~ Where more than 25 percent of the air designed to be supplied by the system is to spaces that are designed to be humidified above 35°F (1.7°C) dew-point temperature to satisfy process needs.
3. ~~Where more than 25 percent of the air designed to be supplied by the system is to spaces that are designed to be humidified above 35°F (1.7°C) dew point temperature to satisfy process needs.~~ Systems expected to operate less than 20 hours per week.
4. ~~Systems that serve residential spaces where the system capacity is less than five times the requirement listed in Table C403.3(1).~~ Systems serving supermarket areas with open refrigerated casework.
5. Where the cooling efficiency ~~meets or exceeds~~ is greater than or equal to the efficiency requirements in Table C403.3(2)-C403.5(2).
6. ~~Where the use of outdoor air for cooling will affect supermarket open refrigerated casework systems.~~ Systems that include a heat recovery system in accordance with Section C403.4.5-C403.10.5.
7. VRF systems installed with a dedicated outdoor air system.
8. ~~Chilled water cooling systems that are passive (without a fan) or use induction where the total chilled water system capacity less the capacity of fan units with air economizers is less than the minimum specified in Table C403.3(1).~~
9. ~~Systems that include a heat recovery system in accordance with Section C403.4.5.~~

**TABLE C403.3(1)C403.5(1)**

**MINIMUM CHILLED-WATER SYSTEM COOLING CAPACITY FOR DETERMINING ECONOMIZER COOLING REQUIREMENTS**

CLIMATE ZONES (COOLING)	TOTAL CHILLED-WATER SYSTEM CAPACITY LESS CAPACITY OF COOLING UNITS WITH AIR ECONOMIZERS	
	Local Water-cooled water-cooled Chilled- water Systems- chilled-water systems	Air-cooled Chilled- water Systems or District Chilled-Water Systems chilled-water systems or district chilled-water systems
<del>3a, 4a</del> 3A, 4A	720,000 Btu/h	940,000 Btu/h
<del>5a</del> 5A	1,320,000 Btu/h	1,720,000 Btu/h

For SI: 1 British thermal unit per hour = 0.2931 W.

**TABLE ~~C403.3(2)~~C403.5(2)**  
**EQUIPMENT EFFICIENCY PERFORMANCE EXCEPTION  
 FOR ECONOMIZERS**

<del>CLIMATE ZONES</del>	<del>COOLING EQUIPMENT PERFORMANCE IMPROVEMENT (EER OR IPLV)</del>
<del>3A</del>	<del>27% efficiency improvement</del>
<del>4A</del>	<del>42% efficiency improvement</del>
<del>5A</del>	<del>49% efficiency improvement</del>

<u>CLIMATE ZONES</u>	<u>COOLING EQUIPMENT PERFORMANCE IMPROVEMENT (EER OR IPLV)</u>
<u>3A</u>	<u>15% efficiency improvement</u>
<u>4A</u>	<u>20% efficiency improvement</u>

**~~C403.3.1~~C403.5.1 Integrated economizer control.** Economizer systems shall be integrated with the mechanical cooling system and be ~~capable of providing~~ configured to provide partial cooling even where additional mechanical cooling is required to provide the remainder of the cooling load. Controls shall not be capable of creating a false load in the mechanical cooling systems by limiting or disabling the economizer or any other means, such as hot gas bypass, except at the lowest stage of mechanical cooling.

Units that include an air economizer shall comply with the following:

1. Unit controls shall have the mechanical cooling capacity control interlocked with the air economizer controls such that the outdoor air damper is at the 100-percent open position when mechanical cooling is on and the outdoor air damper does not begin to close to prevent coil freezing due to minimum compressor run time until the leaving air temperature is less than 45°F (7°C).
2. Direct expansion (DX) units that control 75,000 Btu/h (22 kW) or greater of rated capacity of the capacity of the mechanical cooling directly based on occupied space temperature shall have not fewer than two stages of mechanical cooling capacity.
3. Other DX units, including those that control space temperature by modulating the airflow to the space, shall be in accordance with ~~Table C403.3.1~~ C403.5.1.

**TABLE ~~C403.3.1~~C403.5.1**  
**DX COOLING STAGE REQUIREMENTS  
 FOR MODULATING AIRFLOW UNITS**

RATING CAPACITY	MINIMUM NUMBER OF MECHANICAL COOLING STAGES	MINIMUM COMPRESSOR DISPLACEMENT <sup>a</sup>
≥ 65,000 Btu/h and < 240,000 Btu/h	3 stages	≤ 35% of full load
≥ 240,000 Btu/h	4 stages	≤ 25% full load

For SI: 1 British thermal unit per hour = 0.2931 W.

a. For mechanical cooling stage control that does not use variable compressor displacement, the percent displacement shall be equivalent to the mechanical cooling capacity reduction evaluated at the full load rating conditions for the compressor.

~~C403.3.2~~**C403.5.2 Economizer heating system impact.** HVAC system design and economizer controls shall be such that economizer operation does not increase building heating energy use during normal operation.

**Exception:** Economizers on variable air volume (VAV) systems that cause zone level heating to increase ~~due to~~ because of a reduction in supply air temperature.

~~C403.3.3~~**C403.5.3 Air economizers.** ~~Where economizers are required by Section C403.5, air economizers shall comply with Sections C403.3.3.1 through C403.3.3.5.~~

~~C403.3.3.1~~**C403.5.3.1 Design capacity.** Air economizer systems shall be ~~capable of~~ configured to modulate *outdoor air* and return air dampers to provide up to 100 percent of the design supply air quantity as *outdoor air* for cooling.

~~C403.3.3.2~~**C403.5.3.2 Control signal.** Economizer controls and dampers shall be ~~capable of being~~ configured to sequence the dampers with the mechanical cooling equipment and shall not be controlled by only mixed-air temperature.

**Exception:** The use of mixed-air temperature limit control shall be permitted for systems controlled from space temperature (such as single-zone systems).

~~C403.3.3.3~~**C403.5.3.3 High-limit shutoff.** Air economizers shall be ~~capable of~~ configured to automatically reduce *outdoor air* intake to the design minimum *outdoor air* quantity when *outdoor air* intake will not reduce cooling energy usage. High-limit shutoff control types for specific climates shall be chosen from Table C403.5.3.3. High-limit shutoff control settings for these control types shall be those specified in Table C403.5.3.3.

**TABLE C403.5.3.3  
HIGH-LIMIT SHUTOFF CONTROL SETTING FOR AIR ECONOMIZERS<sup>b</sup>**

DEVICE TYPE	CLIMATE ZONE	REQUIRED HIGH LIMIT (ECONOMIZER OFF WHEN):	
		Equation	Description
Fixed dry bulb	5A	$T_{OA} > 70^{\circ}\text{F}$	Outdoor air temperature exceeds 70°F
	3A, 4A	$T_{OA} > 65^{\circ}\text{F}$	Outdoor air temperature exceeds 65°F
Differential dry bulb	5A	$T_{OA} > T_{RA}$	Outdoor air temperature exceeds return air temperature
Fixed enthalpy with fixed dry-bulb temperatures	All	$h_{OA} > 28 \text{ Btu/lb}^a$ or $T_{OA} > 75^{\circ}\text{F}$	Outdoor air enthalpy exceeds 28 Btu/lb of dry air <sup>a</sup> or Outdoor air temperature exceeds 75°F
Differential enthalpy with fixed dry-bulb temperature	All	$h_{OA} > h_{RA}$ or $T_{OA} > 75^{\circ}\text{F}$	Outdoor air enthalpy exceeds return air enthalpy or Outdoor air temperature exceeds 75°F

For SI: °C = (°F – 32)/1.8, 1 Btu/lb = 2.33 kJ/kg.

a. At altitudes substantially different than sea level, the fixed enthalpy limit shall be set to the enthalpy value at 75°F and 50-percent relative humidity. As an example, at approximately 6,000 feet elevation, the fixed enthalpy limit is approximately 30.7 Btu/lb.

b. Devices with selectable setpoints shall be capable of being set to within 2°F and 2 Btu/lb of the setpoint listed.

~~C403.3.3.4~~**C403.5.3.4 Relief of excess outdoor air.** Systems shall be capable of relieving excess *outdoor air* during air economizer operation to prevent overpressurizing the building. The relief air outlet shall be located to avoid recirculation into the building.

~~C403.3.3.5~~**C403.5.3.5 Economizer dampers.** Return, exhaust/relief and outdoor air dampers used in economizers shall comply with Section ~~C403.2.4.3~~C403.7.7.

~~C403.3.4~~**C403.5.4 Water-side economizers.** ~~Water-side~~Where economizers are required by Section C403.5, water-side economizers shall comply with Sections ~~C403.3.4.1~~**C403.5.4.1** and ~~C403.3.4.2~~**C403.5.4.2**.

~~C403.3.4.1~~**C403.5.4.1 Design capacity.** Water economizer systems shall be ~~capable of cooling~~**configured to cool** supply air by indirect evaporation and providing up to 100 percent of the expected system cooling load at *outdoor air* temperatures of not greater than 50°F (10°C) dry bulb/45°F (7°C) wet bulb.

**Exceptions:** Allowed in lieu of the design capacity provisions identified above:

1. Systems primarily serving computer rooms in which 100 percent of the expected system cooling load at 40°F (4°C) dry bulb/35°F (1.7°C) wet bulb is met with evaporative water economizers.
2. Systems primarily serving computer rooms with dry cooler water economizers that satisfy 100 percent of the expected system cooling load at 35°F (1.7°C) dry bulb.
3. Systems where dehumidification requirements cannot be met using outdoor air temperatures of 50°F (10°C) dry bulb/45°F (7°C) wet bulb and where 100 percent of the expected system cooling load at 45°F (7°C) dry bulb/40°F (4°C) wet bulb is met with evaporative water economizers.

~~C403.3.4.2~~**C403.5.4.2 Maximum pressure drop.** Precooling coils and water-to-water heat exchangers used as part of a water economizer system shall either have a water-side pressure drop of less than 15 feet (45 kPa) of water or a secondary loop shall be created so that the coil or heat exchanger pressure drop is not seen by the circulating pumps when the system is in the normal cooling (noneconomizer) mode.

~~C403.2.4.7~~**C403.5.5 Economizer fault detection and ~~diagnostics (FDD)~~diagnostics.** ~~Deleted.~~Air-cooled unitary direct-expansion units listed in the tables in Section C403.3.2 and variable refrigerant flow (VRF) units that are equipped with an economizer in accordance with Sections C403.5 through C403.5.4 shall include a fault detection and diagnostics system complying with the following:

1. The following temperature sensors shall be permanently installed to monitor system operation:
  - 1.1. Outside air.
  - 1.2. Supply air.
  - 1.3. Return air.
2. Temperature sensors shall have an accuracy of ±2°F (1.1°C) over the range of 40°F to 80°F (4°C to 26.7°C).
3. Refrigerant pressure sensors, where used, shall have an accuracy of ±3 percent of full scale.
4. The unit controller shall be configured to provide system status by indicating the following:
  - 4.1. Free cooling available.
  - 4.2. Economizer enabled.
  - 4.3. Compressor enabled.
  - 4.4. Heating enabled.
  - 4.5. Mixed air low limit cycle active.
  - 4.6. The current value of each sensor.
5. The unit controller shall be capable of manually initiating each operating mode so that the operation of compressors, economizers, fans and the heating system can be independently tested and verified.
6. The unit shall be configured to report faults to a fault management application available for *access* by day-to-day operating or service personnel, or annunciated locally on zone thermostats.
7. The fault detection and diagnostics system shall be configured to detect the following faults:
  - 7.1. Air temperature sensor failure/fault.
  - 7.2. Not economizing when the unit should be economizing.
  - 7.3. Economizing when the unit should not be economizing.
  - 7.4. Damper not modulating.

## 7.5. Excess outdoor air.

~~C403.4.4~~**C403.6 Requirements for complex mechanical systems serving multiple zones.** Sections ~~C403.4.4.1~~C403.6.1 through ~~C403.4.4.6~~C403.6.9 shall apply to complex mechanical systems serving multiple zones. ~~Supply air systems serving multiple zones shall be variable air volume (VAV) systems that, during periods of occupancy, are designed and capable of being controlled to reduce primary air supply to each zone to one of the following before reheating, recooling or mixing takes place:~~

**C403.6.1 Variable air volume and multiple-zone systems.** Supply air systems serving multiple zones shall be variable air volume (VAV) systems that have zone controls configured to reduce the volume of air that is reheated, recooling or mixed in each zone to one of the following:

1. ~~Thirty percent of the maximum supply air to each zone.~~Twenty percent of the zone design peak supply for systems with direct digital control (DDC) and 30 percent for other systems.
2. ~~Three hundred cfm (142 L/s) or less where the maximum flow rate is less than 10 percent of the total fan system supply airflow rate.~~Systems with DDC where all of the following apply:
  - 2.1. The airflow rate in the deadband between heating and cooling does not exceed 20 percent of the zone design peak supply rate or higher allowed rates under Items 3, 4 and 5 of this section.
  - 2.2. The first stage of heating modulates the zone supply air temperature setpoint up to a maximum setpoint while the airflow is maintained at the deadband flow rate.
  - 2.3. The second stage of heating modulates the airflow rate from the deadband flow rate up to the heating maximum flow rate that is less than 50 percent of the zone design peak supply rate.
3. The outdoor airflow rate required to meet the minimum ventilation requirements of Chapter 4 of the *International Mechanical Code*.
4. Any higher rate that can be demonstrated to reduce overall system annual energy use by offsetting reheat/recool energy losses through a reduction in outdoor air intake for the system.system as approved by the code official.
5. The airflow rate required to comply with applicable codes or accreditation standards such as pressure relationships or minimum air change rates.

**Exception:** The following individual zones or entire air distribution systems are exempted from the requirement for VAV control:

1. ~~Zones or supply air systems where not less than 75 percent of the energy for reheating or for providing warm air in mixing systems is provided from a site-recovered~~site-recovered, including condenser heat, or site-solar energy source.
2. ~~Zones where special humidity levels are required to satisfy process needs.~~Systems that prevent reheating, recooling, mixing or simultaneous supply of air that has been previously cooled, either mechanically or through the use of economizer systems, and air that has been previously mechanically heated.
3. ~~Zones with a peak supply air quantity of 300 cfm (142 L/s) or less and where the flow rate is less than 10 percent of the total fan system supply airflow rate.~~
4. ~~Zones where the volume of air to be reheated, recooling or mixed is not greater than the volume of outside air required to provide the minimum ventilation requirements of Chapter 4 of the *International Mechanical Code*.~~
5. ~~Zones or supply air systems with thermostatic and humidistatic controls capable of operating in sequence the supply of heating and cooling energy to the zones and which are capable of preventing reheat ing, recooling, mixing or simultaneous supply of air that has been previously cooled, either mechanically or through the use of economizer systems, and air that has been previously mechanically heated.~~

~~C403.4.4.1~~**C403.6.2 Single-duct VAV systems, terminal devices.** Single-duct VAV systems shall use terminal devices capable of ~~reducing~~and configured to reduce the supply of primary supply air before reheating or recooling takes place.

~~C403.4.4.2~~**C403.6.3 Dual-duct and mixing VAV systems, terminal devices.** Systems that have one warm air duct and one cool air duct shall use terminal devices that are ~~capable of reducing~~configured to reduce the flow from one duct to a minimum before mixing of air from the other duct takes place.

~~C403.4.4.3~~**C403.6.4 Single-fan dual-duct and mixing VAV systems, economizers.** Individual dual-duct or mixing heating and cooling systems with a single fan and with total capacities greater than 90,000 Btu/h [(26.4 kW) 7.5 tons] shall not be equipped with air economizers.

~~C403.4.4.5~~**C403.6.5 Supply-air temperature reset controls.** Multiple-zone HVAC systems shall include controls that are capable of and configured to automatically reset the supply-air temperature in response to representative building loads, or to outdoor air temperature. The controls shall be ~~capable of resetting~~ configured to reset the supply air temperature not less than 25 percent of the difference between the design supply-air temperature and the design room air temperature. Controls that adjust the reset based on zone humidity are allowed in Climate Zones 4 through 5. HVAC zones that are expected to experience relatively constant loads shall have maximum airflow designed to accommodate the fully reset supply-air temperature.

**Exceptions:**

1. Systems that prevent reheating, recooling or mixing of heated and cooled supply air.
2. Seventy-five percent of the energy for reheating is from site-recovered or site-solar energy sources.
3. ~~Zones with peak supply air quantities of 300 cfm (142 L/s) or less. Systems in Climate Zone 3A with less than 3,000 cfm (1500 L/s) of design outside air.~~
4. Deleted.
5. Systems in Climate Zone 3A with not less than 80 percent outside air and employing exhaust air energy recovery complying with Section C403.7.4.

**C403.6.5.1 Dehumidification control interaction.** In Climate Zone 3A, the system design shall allow supply-air temperature reset while dehumidification is provided. When dehumidification control is active, air economizers shall be locked out.

~~C403.4.4.6~~**C403.6.6 Multiple-zone VAV system ventilation optimization control.** ~~Deleted.~~ Multiple-zone VAV systems with direct digital control of individual zone boxes reporting to a central control panel shall have automatic controls configured to reduce outdoor air intake flow below design rates in response to changes in system ventilation efficiency ( $E_v$ ) as defined by the *International Mechanical Code*.

**Exceptions:**

1. VAV systems with zonal transfer fans that recirculate air from other zones without directly mixing it with outdoor air, dual-duct dual-fan VAV systems, and VAV systems with fan-powered terminal units.
2. Systems where total design exhaust airflow is more than 70 percent of total design outdoor air intake flow requirements.

**C403.6.7 Parallel-flow fan-powered VAV air terminal control.** Parallel-flow fan-powered VAV air terminals shall have automatic controls configured to:

1. Turn off the terminal fan except when space heating is required or where required for ventilation.
2. Turn on the terminal fan as the first stage of heating before the heating coil is activated.
3. During heating for warmup or setback temperature control, either:
  - 3.1. Operate the terminal fan and heating coil without primary air.
  - 3.2. Reverse the terminal damper logic and provide heating from the central air handler by primary air.

~~C403.4.1.3~~**C403.6.8 Setpoints for direct digital control.** For systems with direct digital control of individual zones reporting to the central control panel, the static pressure setpoint shall be reset based on the *zone* requiring the most pressure. In such case, the setpoint is reset lower until one zone damper is nearly wide open. The direct digital controls shall be capable of monitoring zone damper positions or shall have an alternative method of indicating the need for static pressure that is configured to provide all of the following:

1. Automatic detection of any zone that excessively drives the reset logic.
2. Generation of an alarm to the system operational location.
3. Allowance for an operator to readily remove one or more zones from the reset algorithm.

~~C403.4.1.2~~**C403.6.9 Static pressure sensor location.** Deleted. Static pressure sensors used to control VAV fans shall be located such that the controller setpoint is not greater than 1.2 inches w.c. (299 Pa). Where this results in one or more sensors being located downstream of major duct splits, not less than one sensor shall be located on each major branch to ensure that static pressure can be maintained in each branch.

**C403.7 Ventilation and exhaust systems.** In addition to other requirements of Section C403 applicable to the provision of ventilation air or the exhaust of air, ventilation and exhaust systems shall be in accordance with Sections C403.7.1 through C403.7.7.

~~C403.2.6.1~~**C403.7.1 Demand controlled ventilation.** Demand control ventilation (DCV) shall be provided for spaces larger than 500 square feet (46.5 m<sup>2</sup>) and with an occupant load of 25 people or greater per 1,000 square feet (93 m<sup>2</sup>) of floor area (as established in Table 403.3.1.1 of the *International Mechanical Code*). Additionally, demand control ventilation is required for any HVAC system provided with outside air greater than 3,000 cfm.

Exception: Demand control ventilation is not required for systems and spaces as follows:

1. Systems with energy recovery complying with Section C403.2.7.
2. Multiple zone systems without direct digital control of individual zones communicating with a central control panel.
3. Systems with a design outdoor airflow less than 1,200 cfm (566 L/s).
4. Spaces where the supply airflow rate minus any makeup or outgoing transfer air requirement is less than 1,200 cfm (566 L/s).
5. Ventilation provided for process loads only.

Demand control ventilation (DCV) shall be provided for all single-zone systems required to comply with Sections C403.5 through C403.5.3 and spaces larger than 500 square feet (46.5 m<sup>2</sup>) and with an average occupant load of 15 people or greater per 1,000 square feet (93 m<sup>2</sup>) of floor area, as established in Table 403.3.1.1 of the *International Mechanical Code*, and served by systems with one or more of the following:

1. An air-side economizer.
2. Automatic modulating control of the outdoor air damper.
3. A design outdoor airflow greater than 3,000 cfm (1416 L/s).

**Exceptions:**

1. Systems with energy recovery complying with Section C403.7.4.2.
2. Multiple-zone systems without direct digital control of individual zones communicating with a central control panel.
3. Multiple-zone systems with a design outdoor airflow less than 750 cfm (354 L/s).
4. Spaces where more than 75 percent of the space design outdoor airflow is required for makeup air that is exhausted from the space or transfer air that is required for makeup air that is exhausted from other spaces.
5. Spaces with one of the following occupancy classifications as defined in Table 403.3.1.1 of the *International Mechanical Code*: correctional cells, education laboratories, barber, beauty and nail salons, and bowling alley seating areas.

~~C403.2.6.2~~**C403.7.2 Enclosed parking garage ventilation controls.** Deleted. Enclosed parking garages used for storing or handling automobiles operating under their own power shall employ carbon monoxide detectors applied in conjunction with nitrogen dioxide detectors and automatic controls configured to stage fans or modulate fan average airflow rates to 50 percent or less of design capacity, or intermittently operate fans less than 20 percent of the occupied time or as required to maintain acceptable contaminant levels in accordance with *International Mechanical Code* provisions. Failure of contamination-sensing devices shall cause the exhaust fans to operate continuously at design airflow.

**Exceptions:**

1. Garages with a total exhaust capacity less than 8,000 cfm (3,755 L/s) with ventilation systems that do not utilize heating or mechanical cooling.
2. Garages that have a garage area to ventilation system motor nameplate power ratio that exceeds 1,125 cfm/hp (710 L/s/kW) and do not utilize heating or mechanical cooling.



**C403.7.3 Ventilation air heating control.** Units that provide ventilation air to multiple zones and operate in conjunction with zone heating and cooling systems shall not use heating or heat recovery to warm supply air to a temperature greater than 60°F (16°C) when representative building loads or outdoor air temperatures indicate that the majority of zones require cooling.

**C403.7.4 Energy recovery systems.** Energy recovery ventilation systems shall be provided as specified in either Section C403.7.4.1 or C403.7.4.2, as applicable.

**C403.7.4.1 Nontransient dwelling units.** Nontransient dwelling units shall be provided with outdoor air energy recovery ventilation systems with an enthalpy recovery ratio of not less than 50 percent at cooling design condition and not less than 60 percent at heating design condition.

**Exceptions:**

1. Deleted.
2. Deleted.
3. Deleted.
4. Enthalpy recovery ratio requirements at cooling design condition in Climate Zones 4 and 5.

**C403.2.7 Energy recovery ventilation systems.** Individual fan systems that have both a design supply air capacity of 5,000 cfm (2.36 m<sup>3</sup>/s) or greater and a minimum outside air supply of 70 percent or greater of the design supply air quantity shall have an energy recovery system that provides a change in the enthalpy of the outdoor air supply of 50 percent or more of the difference between the outdoor air and return air at design conditions. Provision shall be made to bypass or control the energy recovery system to permit cooling with outdoor air where cooling with outdoor air is required.

**C403.7.4.2 Spaces other than nontransient dwelling units.** Where the supply airflow rate of a fan system serving a space other than a nontransient dwelling unit exceeds the values specified in Tables C403.7.4.2(1) and C403.7.4.2(2), the system shall include an energy recovery system. The energy recovery system shall provide an enthalpy recovery ratio of not less than 50 percent at design conditions. Where an air economizer is required, the energy recovery system shall include a bypass or controls that permit operation of the economizer as required by Section C403.5.

**Exception:** An energy recovery ventilation system shall not be required in any of the following conditions:

1. Where energy recovery systems are prohibited by the *International Mechanical Code*.
2. Laboratory fume hood systems that include at least one of the following features:
  - 2.1. Variable-air-volume hood exhaust and room supply systems capable of reducing exhaust and makeup air volume to 50 percent or less of design values.
  - 2.2. Direct makeup (auxiliary) air supply equal to at least 75 percent of the exhaust rate, heated no warmer than 2°F (1.1°C) below room setpoint, cooled to no cooler than 3°F (1.7°C) above room setpoint, no humidification added, and no simultaneous heating and cooling used for dehumidification control.
3. Systems serving spaces that are not cooled and are heated to less than 60°F (15.5°C).
4. Where more than 60 percent of the outdoor heating energy is provided from site-recovered or site solar energy.
5. ~~Heating systems in climates with less than 3,600 HDD.~~ Deleted.
6. ~~Cooling systems in climates with a 1 percent cooling design wet bulb temperature less than 64°F (18°C).~~ Deleted.
7. Systems requiring dehumidification that employ energy recovery in series with the cooling coil.
8. Where the largest source of air exhausted at a single location at the building exterior is less than 75 percent of the design outdoor air flow rate.
9. Systems expected to operate less than 20 hours per week at the outdoor air percentage covered by Table C403.7.4.2(1).
10. Systems exhausting toxic, flammable, paint or corrosive fumes or dust.
11. Commercial kitchen hoods used for collecting and removing grease vapors and smoke.

**TABLE C403.7.4.2(1)**

**ENERGY RECOVERY REQUIREMENT (Ventilation systems operating less than 8,000 hours per year)**

CLIMATE ZONE	PERCENT (%) OUTDOOR AIR AT FULL DESIGN AIRFLOW RATE							
	$\geq 10\%$ and $< 20\%$	$\geq 20\%$ and $< 30\%$	$\geq 30\%$ and $< 40\%$	$\geq 40\%$ and $< 50\%$	$\geq 50\%$ and $< 60\%$	$\geq 60\%$ and $< 70\%$	$\geq 70\%$ and $< 80\%$	$\geq 80\%$
	Design Supply Fan Airflow Rate (cfm)							
<u>3A, 4A, 5A</u>	$\geq 26,000$	$\geq 16,000$	$\geq 5,500$	$\geq 4,500$	$\geq 3,500$	$\geq 2,000$	$\geq 1,000$	$\geq 120$

For SI: 1 cfm = 0.4719 L/s.

NR = Not Required.

**TABLE C403.7.4.2(2)**

**ENERGY RECOVERY REQUIREMENT (Ventilation systems operating not less than 8,000 hours per year)**

CLIMATE ZONE	PERCENT (%) OUTDOOR AIR AT FULL DESIGN AIRFLOW RATE							
	$\geq 10\%$ and $< 20\%$	$\geq 20\%$ and $< 30\%$	$\geq 30\%$ and $< 40\%$	$\geq 40\%$ and $< 50\%$	$\geq 50\%$ and $< 60\%$	$\geq 60\%$ and $< 70\%$	$\geq 70\%$ and $< 80\%$	$\geq 80\%$
	Design Supply Fan Airflow Rate (cfm)							
<u>3C</u>	NR	NR	NR	NR	NR	NR	NR	NR
<u>0B, 1B, 2B, 3B, 4C, 5C</u>	NR	$\geq 19,500$	$\geq 9,000$	$\geq 5,000$	$\geq 4,000$	$\geq 3,000$	$\geq 1,500$	$\geq 120$
<u>0A, 1A, 2A, 3A, 4B, 5B</u>	$\geq 2,500$	$\geq 2,000$	$\geq 1,000$	$\geq 500$	$\geq 140$	$\geq 120$	$\geq 100$	$\geq 80$
<u>4A, 5A, 6A, 6B, 7, 8</u>	$\geq 200$	$\geq 130$	$\geq 100$	$\geq 80$	$\geq 70$	$\geq 60$	$\geq 50$	$\geq 40$

For SI: 1 cfm = 0.4719 L/s.

NR = Not Required.

**~~C403.2.8~~C403.7.5 Kitchen exhaust systems.** Deleted. Replacement air introduced directly into the exhaust hood cavity shall not be greater than 10 percent of the hood exhaust airflow rate. Conditioned supply air delivered to any space shall not exceed the greater of the following:

1. The ventilation rate required to meet the space heating or cooling load.
2. The hood exhaust flow minus the available transfer air from adjacent space where available transfer air is considered to be that portion of outdoor ventilation air not required to satisfy other exhaust needs, such as restrooms, and not required to maintain pressurization of adjacent spaces.

Where total kitchen hood exhaust airflow rate is greater than 5,000 cfm (2360 L/s), each hood shall be a factory-built commercial exhaust hood listed by a nationally recognized testing laboratory in compliance with UL 710. Each hood shall have a maximum exhaust rate as specified in Table C403.7.5 and shall comply with one of the following:

1. Not less than 50 percent of all replacement air shall be transfer air that would otherwise be exhausted.

2. Demand ventilation systems on not less than 75 percent of the exhaust air that are configured to provide not less than a 50-percent reduction in exhaust and replacement air system airflow rates, including controls necessary to modulate airflow in response to appliance operation and to maintain full capture and containment of smoke, effluent and combustion products during cooking and idle.
3. Listed energy recovery devices with a sensible heat recovery effectiveness of not less than 40 percent on not less than 50 percent of the total exhaust airflow.

Where a single hood, or hood section, is installed over appliances with different duty ratings, the maximum allowable flow rate for the hood or hood section shall be based on the requirements for the highest appliance duty rating under the hood or hood section.

**Exception:** Where not less than 75 percent of all the replacement air is transfer air that would otherwise be exhausted.

**TABLE C403.7.5  
MAXIMUM NET EXHAUST FLOW RATE, CFM PER LINEAR FOOT OF HOOD LENGTH**

<u>TYPE OF HOOD</u>	<u>LIGHT-DUTY EQUIPMENT</u>	<u>MEDIUM-DUTY EQUIPMENT</u>	<u>HEAVY-DUTY EQUIPMENT</u>	<u>EXTRA-HEAVY-DUTY EQUIPMENT</u>
<u>Wall-mounted canopy</u>	<u>140</u>	<u>210</u>	<u>280</u>	<u>385</u>
<u>Single island</u>	<u>280</u>	<u>350</u>	<u>420</u>	<u>490</u>
<u>Double island (per side)</u>	<u>175</u>	<u>210</u>	<u>280</u>	<u>385</u>
<u>Eyebrow</u>	<u>175</u>	<u>175</u>	<u>NA</u>	<u>NA</u>
<u>Backshelf/Pass-over</u>	<u>210</u>	<u>210</u>	<u>280</u>	<u>NA</u>

For SI: 1 cfm = 0.4719 L/s; 1 foot = 304.8 mm.

NA = Not Allowed.

**C403.7.6 Automatic control of HVAC systems serving guestrooms.** In Group R-1 buildings containing more than 50 guestrooms, each guestroom shall be provided with controls complying with the provisions of Sections C403.7.6.1 and C403.7.6.2. Card key controls comply with these requirements.

**C403.7.6.1 Temperature setpoint controls.** Controls shall be provided on each HVAC system that are capable of and configured with three modes of temperature control.

1. When the guestroom is rented but unoccupied, the controls shall automatically raise the cooling setpoint and lower the heating setpoint by not less than 4°F (2°C) from the occupant setpoint within 30 minutes after the occupants have left the guestroom.
2. When the guestroom is unrented and unoccupied, the controls shall automatically raise the cooling setpoint to not lower than 80°F (27°C) and lower the heating setpoint to not higher than 60°F (16°C). Unrented and unoccupied guestroom mode shall be initiated within 16 hours of the guestroom being continuously occupied or where a *networked guestroom control system* indicates that the guestroom is unrented and the guestroom is unoccupied for more than 20 minutes. A *networked guestroom control system* that is capable of returning the thermostat setpoints to default occupied setpoints 60 minutes prior to the time a guest-room is scheduled to be occupied is not precluded by this section. Cooling that is capable of limiting relative humidity with a setpoint not lower than 65-percent relative humidity during unoccupied periods is not precluded by this section.
3. When the guestroom is occupied, HVAC setpoints shall return to their occupied setpoints once occupancy is sensed.

**C403.7.6.2 Ventilation controls.** Controls shall be provided on each HVAC system that are capable of and configured to automatically turn off the ventilation and exhaust fans within 20 minutes after the occupants leave the guestroom, or *isolation devices* shall be provided to each guestroom that are capable of automatically shutting off the supply of outdoor air to and exhaust air from the guestroom.

**Exception:** Guestroom ventilation systems are not precluded from having an automatic daily pre-occupancy purge cycle that provides daily outdoor air ventilation during unrented periods at the design ventilation rate for 60 minutes, or at a rate and duration equivalent to one air change.

~~C403.2.4.3~~ **C403.7.7 Shutoff dampers.** Outdoor air intake and exhaust openings and stairway and shaft vents shall be provided with Class I motorized dampers. The dampers shall have an air leakage rate not greater than 4 cfm/ft<sup>2</sup> (20.3 L/s × m<sup>2</sup>) of damper surface area at 1.0 inch water gauge (249 Pa) and shall be labeled by an *approved agency* when tested in accordance with AMCA 500D for such purpose. ~~Shutoff dampers are not required in continuously operating exhaust systems.~~

Outdoor air intake and exhaust dampers shall be installed with automatic controls configured to close when the systems or spaces served are not in use or during unoccupied period warm-up and setback operation, unless the systems served require outdoor or exhaust air in accordance with the *International Mechanical Code* or the dampers are opened to provide intentional economizer cooling.

Stairway and shaft vent dampers shall be installed with automatic controls configured to open upon the activation of any fire alarm initiating device of the building's fire alarm system or the interruption of power to the damper.

**Exception:** Gravity (nonmotorized) Nonmotorized gravity dampers shall be permitted to be used as an alternative to motorized dampers for exhaust and relief openings as follows:

1. In buildings less than three stories in height above grade plane.
2. ~~Deleted.~~ In buildings of any height located in *Climate Zone 3*.
3. Where the design exhaust capacity is not greater than 300 cfm (142 L/s).

~~Gravity (nonmotorized)~~ Nonmotorized gravity dampers shall have an air leakage rate not greater than 20 cfm/ft<sup>2</sup> (101.6 L/s × m<sup>2</sup>) where not less than 24 inches (610 mm) in either dimension and 40 cfm/ft<sup>2</sup> (203.2 L/s × m<sup>2</sup>) where less than 24 inches (610 mm) in either dimension. The rate of air leakage shall be determined at 1.0 inch water gauge (249 Pa) when tested in accordance with AMCA 500D for such purpose. The dampers shall be labeled by an *approved agency*.

~~C403.2.12 Air system design and control.~~ Each HVAC system having a total fan system motor nameplate horse power (hp) exceeding 5 hp (3.7 kW) shall comply with the provisions of Sections C403.2.12.1 through C403.2.12.3.

**C403.8 Fans and fan controls.** Fans in HVAC systems shall comply with Sections C403.8.1 through C403.8.6.1.

~~C403.2.12.1~~ **C403.8.1 Allowable fan motor horsepower.** ~~Each HVAC system at fan system design~~ Each HVAC system having a total fan system motor nameplate horsepower exceeding 5 hp (3.7 kW) at fan system design conditions shall not exceed the allowable *fan system motor nameplate hp* (Option 1) or *fan system bhp* (Option 2) shown in Table C403.2.12.1(1). C403.8.1(1). This includes supply fans, exhaust fans, return/relief fans, and fan-powered terminal units associated with systems providing heating or cooling capability. Single-zone variable air volume systems shall comply with the constant volume fan power limitation.

**Exceptions:**

1. Hospital, vivarium and laboratory systems that utilize flow control devices on exhaust or return to maintain space pressure relationships necessary for occupant health and safety or environmental control shall be permitted to use variable volume fan power limitation.
2. Individual exhaust fans with motor nameplate horsepower of 1 hp (0.746 kW) or less are exempt from the allowable fan horsepower requirement.
3. ~~Fans exhausting air from fume hoods. (Note: If this exception is taken, no related exhaust side credits shall be taken from Table C403.2.12.1(2) and the Fume Exhaust Exception Deduction must be taken from Table C403.2.12.1(2).~~

**TABLE C403.2.12.1(1) C403.8.1(1)**

**FAN POWER LIMITATION**

	LIMIT	CONSTANT VOLUME	VARIABLE VOLUME
Option 1: Fan system motor nameplate hp	Allowable nameplate motor hp	hp ≤ CFM <sub>s</sub> × 0.0011	hp ≤ CFM <sub>s</sub> × 0.0015
Option 2: Fan system bhp	Allowable fan system bhp	bhp ≤ CFM <sub>s</sub> × 0.00094 + A	bhp ≤ CFM <sub>s</sub> × 0.0013 + A

For SI: 1 bhp = 735.5 W, 1 hp = 745.5 W, 1 cfm = 0.4719 L/s.

where:

CFM<sub>s</sub> = The maximum design supply airflow rate to conditioned spaces served by the system in cubic feet per minute.

hp = The maximum combined motor nameplate horsepower.

bhp = The maximum combined fan brake horsepower.

A = Sum of  $[PD \times CFM_D / 4131]$ .

where:

PD = Each applicable pressure drop adjustment from Table C403.2.12.1(2) Table C403.8.1(2) in. w.c.

CFM<sub>D</sub> = The design airflow through each applicable device from Table C403.2.12.1(2) C403.8.1(2) in cubic feet per minute.

**TABLE C403.2.12.1(2)**  
**FAN POWER LIMITATION PRESSURE DROP ADJUSTMENT**

DEVICE	ADJUSTMENT
<b>Credits</b>	
Fully ducted return and/or exhaust air systems	0.5 inch w.c. (2.15 in w.c. for laboratory, vivarium and hospital systems)
Return and/or exhaust airflow control devices	0.5 inch w.c.
Exhaust filters, scrubbers or other exhaust treatment	The pressure drop of device calculated at fan system design condition
Particulate filtration credit: MERV 9 thru 12	0.5 inch w.c.
Particulate filtration credit: MERV 13 thru 15	0.9 inch w.c.
Particulate filtration credit: MERV 16 and greater and electronically enhanced filters	Pressure drop calculated at 2x clean filter pressure drop at fan system design condition.
Carbon and other gas-phase air cleaners	Clean filter pressure drop at fan system design condition.
Biosafety cabinet	Pressure drop of device at fan system design condition.
Energy recovery device, other than coil runaround loop	$(2.2 \times \text{energy recovery effectiveness}) - 0.5$ inch w.c. for each airstream.
Coil runaround loop	0.6 inch w.c. for each airstream.
Evaporative humidifier/cooler in series with another cooling coil	Pressure drop of device at fan system design conditions.
Sound attenuation section (fans serving spaces with design background noise goals below NC35)	0.15 inch w.c.
Exhaust system serving fume hoods	0.35 inch w.c.
Laboratory and vivarium exhaust systems in high-rise buildings	0.25 inch w.c./100 feet of vertical duct exceeding 75 feet.
<b>Deductions</b>	
Fume Hood Exhaust Exception (required if Section 403.2.12.1, Exception 3 is taken)	- 1.0 in. w.c.

For SI: 1 inch w.c. = 249 Pa, 1 inch = 25.4 mm.

w.c. = water column, NC = Noise criterion.

**TABLE C403.2.12.1(2) C403.8.1(2)**  
**FAN POWER LIMITATION PRESSURE DROP ADJUSTMENT**

DEVICE	ADJUSTMENT
<b>Credits</b>	
<u>Return air or exhaust systems required by code or accreditation standards to be fully ducted, or systems required to maintain air pressure differentials between adjacent rooms</u>	<u>0.5 inch w.c. (2.15 inches w.c. for laboratory and vivarium systems)</u>
<u>Return and exhaust airflow control devices</u>	<u>0.5 inch w.c.</u>
<u>Exhaust filters, scrubbers or other exhaust treatment</u>	<u>The pressure drop of device calculated at fan system design condition</u>
<u>Particulate filtration credit: MERV 9 thru 12</u>	<u>0.5 inch w.c.</u>
<u>Particulate filtration credit: MERV 13 thru 15</u>	<u>0.9 inch w.c.</u>
<u>Particulate filtration credit: MERV 16 and greater and electronically enhanced filters</u>	<u>Pressure drop calculated at 2 times the clean filter pressure drop at fan system design condition.</u>

<u>Carbon and other gas-phase air cleaners</u>	<u>Clean filter pressure drop at fan system design condition.</u>
<u>Biosafety cabinet</u>	<u>Pressure drop of device at fan system design condition.</u>
<u>Energy recovery device, other than coil runaround loop</u>	<u>For each airstream, (2.2 × energy recovery effectiveness - 0.5) inch w.c.</u>
<u>Coil runaround loop</u>	<u>0.6 inch w.c. for each airstream.</u>
<u>Evaporative humidifier/cooler in series with another cooling coil</u>	<u>Pressure drop of device at fan system design conditions.</u>
<u>Sound attenuation section (fans serving spaces with design background noise goals below NC35)</u>	<u>0.15 inch w.c.</u>
<u>Exhaust system serving fume hoods</u>	<u>0.35 inch w.c.</u>
<u>Laboratory and vivarium exhaust systems in high-rise buildings</u>	<u>0.25 inch w.c./100 feet of vertical duct exceeding 75 feet.</u>
<u>Deductions</u>	
<u>Systems without central cooling device</u>	<u>- 0.6 inch w.c.</u>
<u>Systems without central heating device</u>	<u>- 0.3 inch w.c.</u>
<u>Systems with central electric resistance heat</u>	<u>- 0.2 inch w.c.</u>

For SI: 1 inch w.c. = 249 Pa, 1 inch = 25.4 mm, 1 foot = 304.8 mm.  
w.c. = Water Column, NC = Noise Criterion.

**C403.2.12.2C403.8.2 Motor nameplate horsepower.** For each fan, the fan brake horsepower (bhp) shall be indicated on the construction documents and the selected motor shall be not larger than the first available motor size greater than the following:

1. For fans less than 6 bhp (~~4413 W~~), (4476 W), 1.5 times the fan brake horsepower.
2. For fans 6 bhp (~~4413 W~~)(4476 W) and larger, 1.3 times the fan brake horsepower.
3. ~~Systems complying with Section C403.2.12.1 fan system motor nameplate hp (Option 1).~~

**Exceptions:**

1. Fans equipped with electronic speed control devices to vary the fan airflow as a function of load.
2. Fans with a fan nameplate electrical input power of less than 0.89 kW.
3. Systems complying with Section C403.2.12.1 C403.8.1 fan system motor nameplate hp (Option 1).
4. Fans with motor nameplate horsepower less than 1 hp (746 W).

**C403.2.12.3C403.8.3 Fan efficiency.** ~~Deleted.~~ Each fan and fan array shall have a fan energy index (FEI) of not less than 1.00 at the design point of operation, as determined in accordance with AMCA 208 by an *approved* independent testing laboratory and labeled by the manufacturer. Each fan and fan array used for a variable-air-volume system shall have an FEI of not less than 0.95 at the design point of operation, as determined in accordance with AMCA 208 by an approved independent testing laboratory and labeled by the manufacturer. The FEI for fan arrays shall be calculated in accordance with AMCA 208 Annex C.

**Exceptions:** The following fans are not required to have a fan energy index:

1. Fans that are not embedded fans with motor nameplate horsepower of less than 1.0 hp (0.75 kW) or with a nameplate electrical input power of less than 0.89 kW.
2. Embedded fans that have a motor nameplate horsepower of 5 hp (3.7 kW) or less, or with a fan system electrical input power of 4.1 kW or less.
3. Multiple fans operated in series or parallel as the functional equivalent of a single fan that have a combined motor nameplate horsepower of 5 hp (3.7 kW) or less or with a fan system electrical input power of 4.1 kW or less.

4. Fans that are part of equipment covered in Section C403.3.2.
5. Fans included in an equipment package certified by an *approved agency* for air or energy performance.
6. Ceiling fans, which are defined as nonportable devices suspended from a ceiling or overhead structure for circulating air via the rotation of the blades.
7. Fans used for moving gases at temperatures above 425°F (250°C).
8. Fans used for operation in explosive atmospheres.
9. Reversible fans used for tunnel ventilation.
10. Fans that are intended to operate only during emergency conditions.
11. Fans outside the scope of AMCA 208.

**~~C403.4.4.4~~C403.8.4 Fractional hp fan motors.** ~~Deleted.~~ Motors for fans that are not less than  $\frac{1}{12}$  hp (0.062 kW) and less than 1 hp (0.746 kW) shall be electronically commutated motors or shall have a minimum motor efficiency of 70 percent, rated in accordance with DOE 10 CFR 431. These motors shall have the means to adjust motor speed for either balancing or remote control. The use of belt-driven fans to sheave adjustments for airflow balancing instead of a varying motor speed shall be permitted.

**Exceptions:** The following motors are not required to comply with this section

1. Motors in the airstream within fan coils and terminal units that only provide heating to the space served.
2. Motors in space-conditioning equipment that comply with Section C403.3.2 or Sections C403.8.1. through C403.8.3.
3. Motors that comply with Section C405.8.

**C403.8.5 Low-capacity ventilation fans.** Mechanical ventilation system fans with motors less than  $\frac{1}{12}$  hp (0.062 kW) in capacity shall meet the efficacy requirements of Table C403.8.5 at one or more rating points.

**Exceptions:**

1. Where ventilation fans are a component of a listed heating or cooling appliance.
2. Dryer exhaust duct power ventilators, domestic range hoods and domestic range booster fans that operate intermittently.

**TABLE C403.8.5**  
**LOW-CAPACITY VENTILATION FAN EFFICACY<sup>a</sup>**

FAN LOCATION	AIRFLOW RATE MINIMUM (CFM)	MINIMUM EFFICACY (CFM/WATT)	AIRFLOW RATE MAXIMUM (CFM)
<u>HRV or ERV</u>	<u>Any</u>	<u>1.2 cfm/watt</u>	<u>Any</u>
<u>In-line fan</u>	<u>Any</u>	<u>3.8 cfm/watt</u>	<u>Any</u>
<u>Bathroom, utility room</u>	<u>10</u>	<u>2.8 cfm/watt</u>	<u>&lt; 90</u>
<u>Bathroom, utility room</u>	<u>90</u>	<u>3.5 cfm/watt</u>	<u>Any</u>

For SI: 1 cfm/ft = 47.82 W.

a. Airflow shall be tested in accordance with HVI 916 and listed. Efficacy shall be listed or shall be derived from listed power and airflow. Fan efficacy for fully ducted HRV, ERV, balanced and in-line fans shall be determined at a static pressure not less than 0.2 inch w.c. Fan efficacy for ducted range hoods, bathroom and utility room fans shall be determined at a static pressure not less than 0.1 inch w.c.

**~~C403.4.1.3~~C403.8.6 Fan control.** Controls shall be provided for fans in accordance with ~~Sections C403.4.1.1 through C403.4.1.3.~~ Section C403.8.6.1 and as required for specific systems provided in Section C403.

~~C403.4.1.1~~**C403.8.6.1 Fan airflow control.** Each cooling system listed in Table ~~C403.4.1.1~~ **C403.8.6.1** shall be designed to vary the indoor fan airflow as a function of load and shall comply with the following requirements:

1. Direct expansion (DX) and chilled water cooling units that control the capacity of the mechanical cooling directly based on space temperature shall have not fewer than two stages of fan control. Low or minimum speed shall not be greater than 66 percent of full speed. At low or minimum speed, the fan system shall draw not more than 40 percent of the fan power at full fan speed. Low or minimum speed shall be used during periods of low cooling load and ventilation-only operation.
2. Other units including DX cooling units and chilled water units that control the space temperature by modulating the airflow to the space shall have modulating fan control. Minimum speed shall be not greater than 50 percent of full speed. At minimum speed the fan system shall draw not more than 30 percent of the power at full fan speed. Low or minimum speed shall be used during periods of low cooling load and ventilation-only operation.
3. Units that include an ~~air-side~~ **air-side** economizer in accordance with Section ~~C403.3~~ **C403.5** shall have not fewer than two speeds of fan control during economizer operation.

**Exceptions:**

1. Modulating fan control is not required for chilled water and evaporative cooling units with fan motors of less than 1 hp (0.746 kW) where the units are not used to provide *ventilation air* and the indoor fan cycles with the load.
2. Where the volume of outdoor air required to comply with the ventilation requirements of the *International Mechanical Code* at low speed exceeds the air that would be delivered at the speed defined in Section ~~C403.4.1~~ **C403.8.6**, the minimum speed shall be selected to provide the required *ventilation air*.

~~TABLE C403.4.1.1  
FAN CONTROL REQUIREMENTS~~

<del>COOLING SYSTEM TYPE</del>	<del>FAN MOTOR SIZE</del>	<del>MECHANICAL COOLING CAPACITY</del>
<del>DX cooling</del>	<del>Any</del>	<del>≥ 120,000 Btu/h</del>
<del>Chilled water</del>	<del>≥ 5 hp</del>	<del>Any</del>
<del>Evaporative cooling</del>	<del>≥ 1/4 hp</del>	<del>Any</del>

~~For SI: 1 British thermal unit per hour = 0.2931 W; 1 hp = 0.746 kW.~~

**TABLE C403.8.6.1  
COOLING SYSTEMS**

COOLING SYSTEM TYPE	FAN MOTOR SIZE	MECHANICAL COOLING CAPACITY
DX cooling	Any	≥ 65,000 Btu/h
Chilled water and evaporative cooling	≥ 1/4hp	Any

For SI: 1 British thermal unit per hour = 0.2931 W; 1 hp = 0.746 kW.

**C403.9 Large-diameter ceiling fans.** Where provided, large-diameter ceiling fans shall be tested and labeled in accordance with AMCA 230.

~~C403.4.3~~**C403.10 Heat rejection equipment.** Each fan powered by a motor of 7.5 hp (5.6 kW) or larger shall have the capability to operate that fan at two thirds of full speed or less, and shall have controls that automatically change the fan speed to control the leaving fluid temperature or condensing temperature/pressure of the heat rejection device. Heat rejection



equipment, including air-cooled condensers, dry coolers, open-circuit cooling towers, closed-circuit cooling towers and evaporative condensers, shall comply with this section.

**Exception:** ~~Factory installed heat rejection devices within HVAC equipment tested and rated in accordance with Tables C403.2.3(6) and C403.2.3(7).~~ Heat rejection devices where energy usage is included in the equipment efficiency ratings listed in Tables C403.3.2(6) and C403.3.2(7).

**C403.10.1 Fan speed control.** Each fan system powered by an individual motor or array of motors with connected power, including the motor service factor, totaling 5 hp (3.7 kW) or more shall have controls and devices configured to automatically modulate the fan speed to control the leaving fluid temperature or condensing temperature and pressure of the heat rejection device. Fan motor power input shall be not more than 30 percent of design wattage at 50 percent of the design airflow.

**Exceptions:**

1. Fans serving multiple refrigerant or fluid cooling circuits.
2. Condenser fans serving flooded condensers.

**C403.10.2 Multiple-cell heat rejection equipment.** Multiple-cell heat rejection equipment with variable speed fan drives shall be controlled to operate the maximum number of fans allowed that comply with the manufacturer's requirements for all system components and so that all fans operate at the same fan speed required for the instantaneous cooling duty, as opposed to staged on and off operation. The minimum fan speed shall be the minimum allowable speed of the fan drive system in accordance with the manufacturer's recommendations.

**C403.10.3 Limitation on centrifugal fan open-circuit cooling towers.** Centrifugal fan open-circuit cooling towers with a combined rated capacity of 1,100 gpm (4164 L/m) or greater at 95°F (35°C) condenser water return, 85°F (29°C) condenser water supply, and 75°F (24°C) outdoor air wet-bulb temperature shall meet the energy efficiency requirement for axial fan open-circuit cooling towers listed in Table C403.3.2(8).

**Exception:** Centrifugal open-circuit cooling towers that are designed with inlet or discharge ducts or require external sound attenuation.

**C403.10.4 Tower flow turndown.** Open-circuit cooling towers used on water-cooled chiller systems that are configured with multiple- or variable-speed condenser water pumps shall be designed so that all open-circuit cooling tower cells can be run in parallel with the larger of the flow that is produced by the smallest pump at its minimum expected flow rate or at 50 percent of the design flow for the cell.

~~C403.4.5~~**C403.10.5 Heat recovery for service water heating.** Condenser heat recovery shall be installed for heating or re-heating of service hot water provided that the facility operates 24 hours a day, the total installed heat capacity of water-cooled systems exceeds 6,000,000 Btu/hr (1758 kW) of heat rejection, and the design service water heating load exceeds 1,000,000 Btu/h (293 kW).

The required heat recovery system shall have the capacity to provide the smaller of the following:

1. Sixty percent of the peak heat rejection load at design conditions.
2. The preheating required to raise the peak service hot water draw to 85°F (29°C).

**Exceptions:**

1. Facilities that employ condenser heat recovery for space heating or reheat purposes with a heat recovery design exceeding 30 percent of the peak water-cooled condenser load at design conditions.
2. Facilities that provide 60 percent of their service water heating from site solar or site recovered energy or from other sources.

~~C403.2.14~~**C403.11 Refrigeration equipment performance.** ~~Deleted.~~ Refrigeration equipment performance shall be determined in accordance with Sections C403.11.1 and C403.11.2 for commercial refrigerators, freezers, refrigerator-freezers, walk-in coolers, walk-in freezers and refrigeration equipment. The energy use shall be verified through certification under an *approved* certification program or, where a certification program does not exist, the energy use shall be supported by data furnished by the equipment manufacturer.

**Exception:** Walk-in coolers and walk-in freezers regulated under federal law in accordance with Subpart R of DOE 10 CFR 431.

**C403.11.1 Commercial refrigerators, refrigerator-freezers and refrigeration.** Refrigeration equipment, defined in DOE 10 CFR Part 431.62, shall have an energy use in kWh/day not greater than the values of Table C403.11.1 when tested and rated in accordance with AHRI Standard 1200.

**TABLE C403.11.1  
MINIMUM EFFICIENCY REQUIREMENTS: COMMERCIAL REFRIGERATORS AND FREEZERS AND REFRIGERATION**

<b>EQUIPMENT CATEGORY</b>	<b>CONDENSING UNIT CONFIGURATION</b>	<b>EQUIPMENT FAMILY</b>	<b>RATING TEMP., °F</b>	<b>OPERATING TEMP., °F</b>	<b>EQUIPMENT CLASSIFICATION<sup>a,c</sup></b>	<b>MAXIMUM DAILY ENERGY CONSUMPTION, kWh/day<sup>d,e</sup></b>	<b>TEST STANDARD</b>			
<u>Remote condensing commercial refrigerators and commercial freezers</u>	Remote (RC)	<u>Vertical open (VOP)</u>	<u>38 (M)</u>	<u>≥ 32</u>	<u>VOP.RC.M</u>	<u>0.64 × TDA + 4.07</u>	AHRI 1200			
			<u>0 (L)</u>	<u>&lt; 32</u>	<u>VOP.RC.L</u>	<u>2.20 × TDA + 6.85</u>				
		<u>Semivertical open (SVO)</u>	<u>38 (M)</u>	<u>≥ 32</u>	<u>SVO.RC.M</u>	<u>0.66 × TDA + 3.18</u>				
			<u>0 (L)</u>	<u>&lt; 32</u>	<u>SVO.RC.L</u>	<u>2.20 × TDA + 6.85</u>				
		<u>Horizontal open (HZO)</u>	<u>38 (M)</u>	<u>≥ 32</u>	<u>HZO.RC.M</u>	<u>0.35 × TDA + 2.88</u>				
			<u>0 (L)</u>	<u>&lt; 32</u>	<u>HZO.RC.L</u>	<u>0.55 × TDA + 6.88</u>				
		<u>Vertical closed transparent (VCT)</u>	<u>38 (M)</u>	<u>≥ 32</u>	<u>VCT.RC.M</u>	<u>0.15 × TDA + 1.95</u>				
			<u>0 (L)</u>	<u>&lt; 32</u>	<u>VCT.RC.L</u>	<u>0.49 × TDA + 2.61</u>				
		<u>Horizontal closed transparent (HCT)</u>	<u>38 (M)</u>	<u>≥ 32</u>	<u>HCT.RC.M</u>	<u>0.16 × TDA + 0.13</u>				
			<u>0 (L)</u>	<u>&lt; 32</u>	<u>HCT.RC.L</u>	<u>0.34 × TDA + 0.26</u>				
		<u>Vertical closed solid (VCS)</u>	<u>38 (M)</u>	<u>≥ 32</u>	<u>VCS.RC.M</u>	<u>0.10 × V + 0.26</u>				
			<u>0 (L)</u>	<u>&lt; 32</u>	<u>VCS.RC.L</u>	<u>0.21 × V + 0.54</u>				
		<u>Horizontal closed solid (HCS)</u>	<u>38 (M)</u>	<u>≥ 32</u>	<u>HCS.RC.M</u>	<u>0.10 × V + 0.26</u>				
			<u>0 (L)</u>	<u>&lt; 32</u>	<u>HCS.RC.L</u>	<u>0.21 × V + 0.54</u>				
		<u>Service over counter (SOC)</u>	<u>38 (M)</u>	<u>≥ 32</u>	<u>SOC.RC.M</u>	<u>0.44 × TDA + 0.11</u>				
			<u>0 (L)</u>	<u>&lt; 32</u>	<u>SOC.RC.L</u>	<u>0.93 × TDA + 0.22</u>				
		<u>Self-contained commercial refrigerators and commercial freezers with and without doors</u>	Self-contained (SC)	<u>Vertical open (VOP)</u>	<u>38 (M)</u>	<u>≥ 32</u>		<u>VOP.SC.M</u>	<u>1.69 × TDA + 4.71</u>	AHRI 1200
					<u>0 (L)</u>	<u>&lt; 32</u>		<u>VOP.SC.L</u>	<u>4.25 × TDA + 11.82</u>	
<u>Semivertical open (SVO)</u>	<u>38 (M)</u>			<u>≥ 32</u>	<u>SVO.SC.M</u>	<u>1.70 × TDA + 4.59</u>				
	<u>0 (L)</u>			<u>&lt; 32</u>	<u>SVO.SC.L</u>	<u>4.26 × TDA + 11.51</u>				
<u>Horizontal open (HZO)</u>	<u>38 (M)</u>			<u>≥ 32</u>	<u>HZO.SC.M</u>	<u>0.72 × TDA + 5.55</u>				
	<u>0 (L)</u>			<u>&lt; 32</u>	<u>HZO.RC.L</u>	<u>1.90 × TDA + 7.08</u>				
<u>Vertical closed transparent (VCT)</u>	<u>38 (M)</u>			<u>≥ 32</u>	<u>VCT.SC.M</u>	<u>0.10 × V + 0.86</u>				
	<u>0 (L)</u>			<u>&lt; 32</u>	<u>VCT.SC.L</u>	<u>0.29 × V + 2.95</u>				
<u>Vertical closed solid (VCS)</u>	<u>38 (M)</u>			<u>≥ 32</u>	<u>VCS.SC.M</u>	<u>0.05 × V + 1.36</u>				
	<u>0 (L)</u>			<u>&lt; 32</u>	<u>VCS.SC.L</u>	<u>0.22 × V + 1.38</u>				
<u>Horizontal closed transparent (HCT)</u>	<u>38 (M)</u>			<u>≥ 32</u>	<u>HCT.SC.M</u>	<u>0.06 × V + 0.37</u>				
	<u>0 (L)</u>			<u>&lt; 32</u>	<u>HCT.SC.L</u>	<u>0.08 × V + 1.23</u>				

	<u>Horizontal closed solid (HCS)</u>	<u>38 (M)</u>	<u>≥ 32</u>	<u>HCS.SC.M</u>	<u>0.05 × V + 0.91</u>
		<u>0 (L)</u>	<u>&lt; 32</u>	<u>HCS.SC.L</u>	<u>0.06 × V + 1.12</u>
	<u>Service over counter (SOC)</u>	<u>38 (M)</u>	<u>≥ 32</u>	<u>SOC.SC.M</u>	<u>0.52 × TDA + 1.00</u>
		<u>0 (L)</u>	<u>&lt; 32</u>	<u>SOC.SC.L</u>	<u>1.10 × TDA + 2.10</u>

(continued)

**TABLE C403.11.1—continued**  
**MINIMUM EFFICIENCY REQUIREMENTS: COMMERCIAL REFRIGERATORS AND FREEZERS AND REFRIGERATION**

<b>EQUIPMENT CATEGORY</b>	<b>CONDENSING UNIT CONFIGURATION</b>	<b>EQUIPMENT FAMILY</b>	<b>RATING TEMP., °F</b>	<b>OPERATING TEMP., °F</b>	<b>EQUIPMENT CLASSIFICATION<sup>a,c</sup></b>	<b>MAXIMUM DAILY ENERGY CONSUMPTION, kWh/day<sup>d,e</sup></b>	<b>TEST STANDARD</b>
<u>Self-contained commercial refrigerators with transparent doors for pull-down temperature applications</u>	<u>Self-contained (SC)</u>	<u>Pull-down (PD)</u>	<u>38 (M)</u>	<u>≥ 32</u>	<u>PD.SC.M</u>	<u>0.11 × V + 0.81</u>	<u>AHRI 1200</u>
<u>Commercial ice cream freezers</u>	<u>Remote (RC)</u>	<u>Vertical open (VOP)</u>	<u>-15 (I)</u>	<u>≤ -5<sup>b</sup></u>	<u>VOP.RC.I</u>	<u>2.79 × TDA + 8.70</u>	<u>AHRI 1200</u>
		<u>Semivertical open (SVO)</u>			<u>SVO.RC.I</u>	<u>2.79 × TDA + 8.70</u>	
		<u>Horizontal open (HZO)</u>			<u>HZO.RC.I</u>	<u>0.70 × TDA + 8.74</u>	
		<u>Vertical closed transparent (VCT)</u>			<u>VCT.RC.I</u>	<u>0.58 × TDA + 3.05</u>	
		<u>Horizontal closed transparent (HCT)</u>			<u>HCT.RC.I</u>	<u>0.40 × TDA + 0.31</u>	
		<u>Vertical closed solid (VCS)</u>			<u>VCS.RC.I</u>	<u>0.25 × V + 0.63</u>	
		<u>Horizontal closed solid (HCS)</u>			<u>HCS.RC.I</u>	<u>0.25 × V + 0.63</u>	
		<u>Service over counter (SOC)</u>			<u>SOC.RC.I</u>	<u>1.09 × TDA + 0.26</u>	
	<u>Self-contained (SC)</u>	<u>Vertical open (VOP)</u>			<u>VOP.SC.I</u>	<u>5.40 × TDA + 15.02</u>	<u>AHRI 1200</u>
		<u>Semivertical open (SVO)</u>			<u>SVO.SC.I</u>	<u>5.41 × TDA + 14.63</u>	
		<u>Horizontal open (HZO)</u>			<u>HZO.SC.I</u>	<u>2.42 × TDA + 9.00</u>	
		<u>Vertical closed transparent (VCT)</u>			<u>VCT.SC.I</u>	<u>0.62 × TDA + 3.29</u>	
		<u>Horizontal closed transparent (HCT)</u>			<u>HCT.SC.I</u>	<u>0.56 × TDA + 0.43</u>	
		<u>Vertical closed solid (VCS)</u>			<u>VCS.SC.I</u>	<u>0.34 × V + 0.88</u>	
<u>Horizontal closed solid (HCS)</u>		<u>HCS.SC.I</u>	<u>0.34 × V + 0.88</u>				
<u>Service over counter (SOC)</u>	<u>SOC.SC.I</u>	<u>1.53 × TDA + 0.36</u>					

For SI: 1 square foot = 0.0929 m<sup>2</sup>, 1 cubic foot = 0.02832 m<sup>3</sup>, °C = (°F - 32)/1.8.

a. The meaning of the letters in this column is indicated in the columns to the left.

b. Ice cream freezer is defined in DOE 10 CFR 431.62 as a commercial freezer that is designed to operate at or below -5 °F and that the manufacturer designs, markets or intends for the storing, displaying or dispensing of ice cream.

c. Equipment class designations consist of a combination [in sequential order separated by periods (AAA).(BB).(C)] of the following:

- (AAA)—An equipment family code (VOP = vertical open, SVO = semivertical open, HZO = horizontal open, VCT = vertical closed transparent doors, VCS = vertical closed solid doors, HCT = horizontal closed transparent doors, HCS = horizontal closed solid doors, and SOC = service over counter);
  - (BB)—An operating mode code (RC = remote condensing and SC = self-contained); and
  - (C)—A rating temperature code [M = medium temperature (38°F), L = low temperature (0°F), or I = ice cream temperature (-15°F)].
  - For example, “VOP.RC.M” refers to the “vertical open, remote condensing, medium temperature” equipment class.
- d. V is the volume of the case (ft<sup>3</sup>) as measured in AHRI 1200, Appendix C.
- e. TDA is the total display area of the case (ft<sup>2</sup>) as measured in AHRI 1200, Appendix D.

**~~C403.2.15 Walk-in coolers, walk-in freezers, refrigerated warehouse coolers and refrigerated warehouse freezers.~~**  
~~Deleted. Preempted by Energy Independence and Security Act 2007, Section 312 and 10 CFR 431.306.~~

**~~C403.2.16~~C403.11.2 Walk-in coolers and walk-in freezers.** Deleted. Walk-in cooler and walk-in freezer refrigeration systems, except for walk-in process cooling refrigeration systems as defined in DOE 10 CFR 431.302, shall meet the requirements of Tables C403.11.2.1(1), C403.11.2.1(2) and C403.11.2.1(3). □

**C403.11.2.1 Performance standards.** *Walk-in coolers and walk-in freezers shall meet the requirements of Tables C403.11.2.1(1), C403.11.2.1(2) and C403.11.2.1(3).*

**TABLE C403.11.2.1(1)**  
**WALK-IN COOLER AND FREEZER DISPLAY DOOR**  
**EFFICIENCY REQUIREMENTS<sup>a</sup>**

CLASS DESCRIPTOR	CLASS	MAXIMUM ENERGY CONSUMPTION (kWh/day) <sup>a</sup>
Display door, medium temperature	DD, M	$0.04 \times A_{dd} + 0.41$
Display door, low temperature	DD, L	$0.15 \times A_{dd} + 0.29$

a.  $A_{dd}$  is the surface area of the display door.

**TABLE C403.11.2.1(2)**  
**WALK-IN COOLER AND FREEZER NONDISPLAY**  
**DOOR EFFICIENCY REQUIREMENTS<sup>a</sup>**

CLASS DESCRIPTOR	CLASS	MAXIMUM ENERGY CONSUMPTION (kWh/day) <sup>a</sup>
Passage door, medium temperature	PD, M	$0.05 \times A_{nd} + 1.7$
Passage door, low temperature	PD, L	$0.14 \times A_{nd} + 4.8$
Freight door, medium temperature	FD, M	$0.04 \times A_{nd} + 1.9$
Freight door, low temperature	FD, L	$0.12 \times A_{nd} + 5.6$

a.  $A_{nd}$  is the surface area of the nondisplay door.

**TABLE C403.11.2.1(3)**  
**WALK-IN COOLER AND FREEZER REFRIGERATION SYSTEM EFFICIENCY REQUIREMENTS**

CLASS DESCRIPTOR	CLASS	MINIMUM ANNUAL WALK-IN ENERGY FACTOR AWEF (Btu/W-h) <sup>a</sup>	TEST PROCEDURE
------------------	-------	--	----------------

Dedicated condensing, medium temperature, indoor system <input type="checkbox"/>	<u>DC.M.I</u>	<u>5.61</u>	<u>AHRI 1250</u>
Dedicated condensing, medium temperature, outdoor system <input type="checkbox"/>	<u>DC.M.O</u>	<u>7.60</u>	
Dedicated condensing, low temperature, indoor system, net capacity ( $q_{net}$ ) < 6,500 Btu/h	<u>DC.L.I, &lt; 6,500</u>	<u><math>9.091 \times 10^{-5} \times q_{net} + 1.81</math></u>	
Dedicated condensing, low temperature, indoor system, net capacity ( $q_{net}$ ) ≥ 6,500 Btu/h	<u>DC.L.I, ≥ 6,500</u>	<u>2.40</u>	
Dedicated condensing, low temperature, outdoor system, net capacity ( $q_{net}$ ) < 6,500 Btu/h	<u>DC.L.O, &lt; 6,500</u>	<u><math>6.522 \times 10^{-5} \times q_{net} + 2.73</math></u>	
Dedicated condensing, low temperature, outdoor system, net capacity ( $q_{net}$ ) ≥ 6,500 Btu/h	<u>DC.L.O, ≥ 6,500</u>	<u>3.15</u>	
<u>Unit cooler, medium</u>	<u>UC.M</u>	<u>9.00</u>	
<u>Unit cooler, low temperature, net capacity (<math>q_{net}</math>) &lt; 15,500 Btu/h</u>	<u>UC.L, &lt; 15,500</u>	<u><math>1.575 \times 10^{-5} \times q_{net} + 3.91</math></u>	
<u>Unit cooler, low temperature, net capacity (<math>q_{net}</math>) ≥ 15,500 Btu/h</u>	<u>UC.L, ≥ 15,500</u>	<u>4.15</u>	

For SI: 1 British thermal unit per hour = 0.2931 W.

a.  $q_{net}$  is net capacity (Btu/h) as determined in accordance with AHRI 1250.

**~~C403.2.17 Refrigerated display cases.~~ Deleted.**

**~~C403.5C403.11.3 Refrigeration systems.~~ Deleted.** Refrigerated display cases, walk-in coolers or walk-in freezers that are served by remote compressors and remote condensers not located in a condensing unit, shall comply with Sections C403.11.3.1 and C403.11.3.2.

**Exception:** Systems where the working fluid in the refrigeration cycle goes through both subcritical and super-critical states (transcritical) or that use ammonia refrigerant are exempt.

**C403.11.3.1 Condensers serving refrigeration systems.** Fan-powered condensers shall comply with the following:

1. The design saturated condensing temperatures for air-cooled condensers shall not exceed the design dry-bulb temperature plus 10°F (5.6°C) for low-temperature refrigeration systems, and the design dry-bulb temperature plus 15°F (8°C) for medium temperature refrigeration systems where the saturated condensing temperature for blend refrigerants shall be determined using the average of liquid and vapor temperatures as converted from the condenser drain pressure.
2. Condenser fan motors that are less than 1 hp (0.75 kW) shall use electronically commutated motors, permanent split-capacitor-type motors or 3-phase motors.
3. Condenser fans for air-cooled condensers, evaporatively cooled condensers, air- or water-cooled fluid coolers or cooling towers shall reduce fan motor demand to not more than 30 percent of design wattage at 50 percent of design air volume, and incorporate one of the following continuous variable speed fan control approaches:
  - 3.1. Refrigeration system condenser control for air-cooled condensers shall use variable setpoint control logic to reset the condensing temperature setpoint in response to ambient dry-bulb temperature.
  - 3.2. Refrigeration system condenser control for evaporatively cooled condensers shall use variable setpoint control logic to reset the condensing temperature setpoint in response to ambient wet-bulb temperature.
4. Multiple fan condensers shall be controlled in unison.
5. The minimum condensing temperature setpoint shall be not greater than 70°F (21°C).

**C403.11.3.2 Compressor systems.** Refrigeration compressor systems shall comply with the following:

1. Compressors and multiple-compressor system suction groups shall include control systems that use floating suction pressure control logic to reset the target suction pressure temperature based on the temperature requirements of the attached refrigeration display cases or walk-ins.

**Exception:** Controls are not required for the following:

1. Single-compressor systems that do not have variable capacity capability.
2. Suction groups that have a design saturated suction temperature of 30°F (-1.1°C) or higher, suction groups that comprise the high stage of a two-stage or cascade system, or suction groups that primarily serve chillers for secondary cooling fluids.
2. Liquid subcooling shall be provided for all low-temperature compressor systems with a design cooling capacity equal to or greater than 100,000 Btu (29.3 kW) with a design-saturated suction temperature of -10°F (-23°C) or lower. The sub-cooled liquid temperature shall be controlled at a maximum temperature setpoint of 50°F (10°C) at the exit of the subcooler using either compressor economizer (interstage) ports or a separate compressor suction group operating at a saturated suction temperature of 18°F (-7.8°C) or higher.
  - 2.1. Insulation for liquid lines with a fluid operating temperature less than 60°F (15.6°C) shall comply with Table C403.11.3.
3. Compressors that incorporate internal or external crankcase heaters shall provide a means to cycle the heaters off during compressor operation.

**C403.12 Construction of HVAC system elements.** Ducts, plenums, piping and other elements that are part of an HVAC system shall be constructed and insulated in accordance with Sections C403.12.1 through C403.12.3.1.

~~C403.2.9~~**C403.12.1 Duct and plenum insulation and sealing.** Supply and return air ducts and plenums shall be insulated with a minimum of R-6 insulation where located in unconditioned spaces inside the building. Where located outdoors, supply and return ducts shall be insulated with a minimum of R-8 insulation in *Climate Zones 3 and 4* and a minimum of R-12 insulation in *Climate Zone 5*. Where located within a building envelope assembly, such as a wall of the building thermal envelope, the duct or plenum shall be separated from the building exterior or unconditioned space by a minimum of R-8 insulation in *Climate Zones 3 and 4* and a minimum of R-12 insulation in *Climate Zone 5*.

**Exception:** Where located within equipment.

Ducts, air handlers and filter boxes shall be sealed. Joints and seams shall comply with Section 603.9 of the *International Mechanical Code*.

Supply and return air ducts and plenums shall be insulated with not less than R-6 insulation where located in unconditioned spaces and where located outside the building with not less than R-8 insulation in *Climate Zones 3 through 4* and not less than R-12 insulation in *Climate Zone 5*. Ducts located underground beneath buildings shall be insulated as required in this section or have an equivalent thermal distribution efficiency. Underground ducts utilizing the thermal distribution efficiency method shall be listed and labeled to indicate the R-value equivalency. Where located within a building envelope assembly, the duct or plenum shall be separated from the building exterior or unconditioned or exempt spaces by not less than R-8 insulation in *Climate Zones 3 through 4* and not less than R-12 insulation in *Climate Zone 5*.

**Exceptions:**

1. Where located within equipment.
2. Where the design temperature difference between the interior and exterior of the duct or plenum is not greater than 15°F (8°C).

Ducts, air handlers and filter boxes shall be sealed. Joints and seams shall comply with Section 603.9 of the *International Mechanical Code*.

~~C403.2.9.1~~**C403.12.2 Duct construction.** Ductwork shall be constructed and erected in accordance with the *International Mechanical Code*.

~~C403.2.9.1.1~~**C403.12.2.1 Low-pressure duct systems.** Longitudinal and transverse joints, seams and connections of supply and return ducts operating at a static pressure less than or equal to 2 inches water gauge (w.g.) (498 Pa) shall be securely fastened and sealed ~~in accordance with Section 603.9 of the International Mechanical Code~~ with welds, gaskets, mastics (adhesives), mas-tic-plus-embedded-fabric systems or tapes installed in accordance with the manufacturer's instructions. Pressure classifications specific to the duct system shall be clearly indicated on the construction documents in accordance with the *International Mechanical Code*.

**Exception:** Locking-type longitudinal joints and seams, other than the snap-lock and button-lock types, need not be sealed as specified in this section.

~~€403.2.9.1.2~~**C403.12.2.2 Medium-pressure duct systems.** Ducts and plenums designed to operate at a static pressure greater than 2 inches water gauge (w.g.) (498 Pa) but less than 3 inches w.g. (747 Pa) shall be insulated and sealed in accordance with Section ~~€403.2.9~~**C403.12.1**. Pressure classifications specific to the duct system shall be clearly indicated on the construction documents in accordance with the *International Mechanical Code*.

~~€403.2.9.1.3~~**C403.12.2.3 High-pressure duct systems.** Ducts and plenums designed to operate at static pressures equal to or greater than 3 inches water gauge (747 Pa) shall be insulated and sealed in accordance with Section ~~€403.2.9~~**C403.12.1**. In addition, ducts and plenums shall be leak tested in accordance with the *SMACNA HVAC Air Duct Leakage Test Manual*. ~~The maximum permitted duct leakage shall be~~SMACNA HVAC Air Duct Leakage Test Manual and shown to have a rate of air leakage (CL) less than or equal to 4.0 as determined in accordance with Equation 4-8.

$$L_{max} = \frac{0.65}{CL} \sqrt{P} \quad \text{(Equation 4-8)}$$

where:

~~$L_{max}$  = Maximum permitted leakage, cfm/100 ft<sup>2</sup> duct surface area.~~

~~$CL$  = 4, duct leakage class, cfm/100 ft<sup>2</sup> duct surface area at inch-w.g.~~

~~$P$  = Test pressure, which shall be equal to the design duct pressure class rating, inches w.g.~~

$$CL = F/P^{0.65} \quad \text{(Equation 4-8)}$$

where:

~~$F$  = The measured leakage rate in cfm per 100 square feet (9.3 m<sup>2</sup>) of duct surface.~~

~~$P$  = The static pressure of the test.~~

Documentation shall be furnished demonstrating that representative sections totaling not less than 25 percent of the duct area have been tested and that all tested sections comply with the requirements of this section.

~~€403.2.10~~**Piping insulation.** All piping serving as part of a heating or cooling system shall be thermally insulated in accordance with Table ~~C403.2.10~~.

**Exceptions:**

- ~~1. Factory installed piping within HVAC equipment tested and rated in accordance with a test procedure referenced by this code.~~
- ~~2. Factory installed piping within room fan coils and unit ventilators tested and rated according to AHRI 440 (except that the sampling and variation provisions of Section 6.5 shall not apply) and 840, respectively.~~
- ~~3. Piping that conveys fluids that have a design operating temperature range between 55°F (13°C) and 105°F (41°C).~~
- ~~4. Piping that conveys fluids that have not been heated or cooled through the use of fossil fuels or electric power.~~
- ~~5. Runout piping not exceeding 4 feet (1219 mm) in length and 1 inch (25 mm) in diameter between the control valve and HVAC coil.~~
- ~~6. Refrigerant suction piping located in conditioned space is not required to be insulated other than as may be necessary for preventing the formation of condensation.~~
- ~~7. Direct buried piping that conveys fluids at or below 60°F (15°C).~~

**TABLE C403.2.10  
MINIMUM PIPING INSULATION THICKNESS<sup>a,b</sup>**

FLUID	NOMINAL PIPE DIAMETER	
	≤ 1.5"	> 1.5"
Steam	1½	3
Hot water	1½	2
Chilled water, brine, or refrigerant	1½	1½

For SI: 1 inch = 25.4 mm.  
a. Based on insulation having a conductivity (k) not exceeding 0.27 Btu · inch/hr · ft<sup>2</sup> · °F.  
b. For insulation with a thermal conductivity not equal to 0.27 Btu · inch/hr · ft<sup>2</sup> · °F at a mean temperature of 75°F, the minimum required pipe thickness is adjusted using the following equation:  
 $T = r[(1 + t/r)^{k/0.27} - 1]$   
where:  
T = Adjusted insulation thickness (in).  
r = Actual pipe radius (in).  
t = Insulation thickness from applicable cell in table (in).  
K = Nom. thermal conductivity at 75°F (Btu · inch/hr · ft<sup>2</sup> · °F).  
k = 0.27 Btu · inch/hr · ft<sup>2</sup> · °F.

**C403.12.3 Piping insulation.** Piping serving as part of a heating or cooling system shall be thermally insulated in accordance with Table C403.12.3.

**Exceptions:**

1. Factory-installed piping within HVAC equipment tested and rated in accordance with a test procedure referenced by this code.
2. Factory-installed piping within room fan-coils and unit ventilators tested and rated according to AHRI 440 (except that the sampling and variation provisions of Section 6.5 shall not apply) and AHRI 840, respectively.
3. Piping that conveys fluids that have a design operating temperature range between 60°F (15°C) and 105°F (41°C).
4. Piping that conveys fluids that have not been heated or cooled through the use of fossil fuels or electric power.
5. Strainers, control valves, and balancing valves associated with piping 1 inch (25 mm) or less in diameter.
6. Direct buried piping that conveys fluids at or below 60°F (15°C).
7. In radiant heating systems, sections of piping intended by design to radiate heat.

**TABLE C403.12.3  
MINIMUM PIPE INSULATION THICKNESS (in inches)<sup>a, c</sup>**

FLUID OPERATING TEMPERATURE RANGE AND USAGE (°F)	INSULATION CONDUCTIVITY		NOMINAL PIPE OR TUBE SIZE (inches)				
	Conductivity Btu × in./[h × ft <sup>2</sup> × °F] <sup>b</sup>	Mean Rating Temperature, °F	< 1	1 to < 1½	1½ to < 4	4 to < 8	≥ 8
≥ 350	0.32–0.34	250	4.5	5.0	5.0	5.0	5.0
251–350	0.29–0.32	200	3.0	4.0	4.5	4.5	4.5
201–250	0.27–0.30	150	2.5	2.5	2.5	3.0	3.0
141–200	0.25–0.29	125	1.5	1.5	2.0	2.0	2.0
105–140	0.21–0.28	100	1.0	1.0	1.5	1.5	1.5
40–60	0.21–0.27	75	0.5	0.5	1.0	1.0	1.0
< 40	0.20–0.26	50	0.5	1.0	1.0	1.0	1.5

For SI: 1 inch = 25.4 mm, °C = [(°F) – 32]/1.8.

- a. For piping smaller than 1½ inches and located in partitions within conditioned spaces, reduction of these thicknesses by 1 inch shall be permitted (before thickness adjustment required in Note b) but not to a thickness less than 1 inch.
- b. For insulation outside the stated conductivity range, the minimum thickness (T) shall be determined as follows:

$$T = r[(1 + t/r)^{K/k} - 1]$$

where:

T = Minimum insulation thickness.



$r$  = Actual outside radius of pipe.

$t$  = Insulation thickness listed in the table for applicable fluid temperature and pipe size.

$K$  = Conductivity of alternate material at mean rating temperature indicated for the applicable fluid temperature (Btu  $\times$  in/h  $\times$  ft<sup>2</sup>  $\times$  °F).

$k$  = The upper value of the conductivity range listed in the table for the applicable fluid temperature.

- c. For direct-buried heating and hot water system piping, reduction of these thicknesses by 1½ inches (38 mm) shall be permitted (before thickness adjustment required in Note b but not to thicknesses less than 1 inch).

~~C403.2.10.1~~**C403.12.3.1 Protection of piping insulation.** Deleted. Piping insulation exposed to the weather shall be protected from damage, including that caused by sunlight, moisture, equipment maintenance and wind, and shall provide shielding from solar radiation that can cause degradation of the material. Adhesive tape shall not be permitted.

**C403.13 Mechanical systems located outside of the building thermal envelope.** Mechanical systems providing heat outside of the thermal envelope of a building shall comply with Sections C403.13.1 through C403.13.3.

~~C403.2.13~~**C403.13.1 Heating outside a building.** Systems installed to provide heat outside a building shall be radiant systems.

Such heating systems shall be controlled by an occupancy sensing device or a timer switch, so that the system is automatically ~~de-energized~~de-energized when occupants are not present.

~~C403.2.4.5~~**C403.13.2 Snow- and ice-melt system controls.** Snow- and ice-melting systems shall include automatic controls capable of shutting off the system when the pavement temperature is above ~~50°F (10°C)~~50°F (10°C) and precipitation is not falling, and an automatic or manual control that is configured to shut off when the outdoor temperature is above 40°F (4°C).

~~C403.2.4.6~~**C403.13.3 Freeze protection system controls.** Freeze protection systems, such as heat tracing of outdoor piping and heat exchangers, including self-regulating heat tracing, shall include automatic controls configured to shut off the systems when outdoor air temperatures are above 40°F (4°C) or when the conditions of the protected fluid will prevent freezing.

**C403.14 Operable opening interlocking controls.** The heating and cooling systems shall have controls that will interlock these mechanical systems to the set temperatures of 90°F (32°C) for cooling and 55°F (12.7°C) for heating when the conditions of Section C402.5.8 exist. The controls shall configure to shut off the systems entirely when the outdoor temperatures are below 90°F (32°C) or above 55°F (12.7°C).

## SECTION C404 SERVICE WATER HEATING (MANDATORY)

**C404.1 General.** This section covers the minimum efficiency of, and controls for, service water-heating equipment and insulation of service hot water piping.

**C404.2 Service water-heating equipment performance efficiency.** Water-heating equipment and hot water storage tanks shall meet the requirements of Table C404.2. The efficiency shall be verified through data furnished by the manufacturer of the equipment or through certification under an *approved* certification program. Water-heating equipment intended to be used to provide space heating shall meet the applicable provisions of Table C404.2.

**C404.2.1 High input service water-heating systems.** Deleted. Gas-fired water-heating equipment installed in new buildings shall be in compliance with this section. Where a singular piece of water-heating equipment serves the entire building and the input rating of the equipment is 1,000,000 Btu/h (293 kW) or greater, such equipment shall have a thermal efficiency,  $E_t$ , of not less than 92 percent. Where multiple pieces of water-heating equipment serve the building and the combined input rating of the water-heating equipment is 1,000,000 Btu/h (293 kW) or greater, the combined input-capacity-weighted-average thermal efficiency,  $E_t$ , shall be not less than 90 percent.

### Exceptions:

1. Where not less than 25 percent of the annual *service water-heating* requirement is provided by *on-site renewable energy* or site-recovered energy, the minimum thermal efficiency requirements of this section shall not apply.
2. The input rating of water heaters installed in individual dwelling units shall not be required to be included in the total input rating of *service water-heating* equipment for a building.

3. The input rating of water heaters with an input rating of not greater than 100,000 Btu/h (29.3 kW) shall not be required to be included in the total input rating of service water-heating equipment for a building.

**C404.3 Heat traps.** Water heating equipment not supplied with integral heat traps and serving noncirculating systems shall be provided with heat traps on the supply and discharge piping associated with the equipment.

**C404.3 Heat traps for hot water storage tanks.** Storage tank-type water heaters and hot water storage tanks that have vertical water pipes connecting to the inlet and outlet of the tank shall be provided with integral heat traps at those inlets and outlets or shall have pipe-configured heat traps in the piping connected to those inlets and outlets. Tank inlets and outlets associated with solar water heating system circulation loops shall not be required to have heat traps.

**C404.4 Insulation of piping.** For automatic circulating hot water systems, piping shall be insulated with 1 inch (25 mm) of insulation having a conductivity not exceeding 0.27 Btu-inch/h × ft<sup>2</sup> × °F (1.53 W · 25 mm/m<sup>2</sup> × K). The first 8 feet (2438 mm) of piping in noncirculating systems served by equipment with out integral heat traps shall be insulated with 0.5 inch (12.7 mm) of material having a conductivity not exceeding 0.27 Btu-inch/h × ft<sup>2</sup> × °F (1.53 W · 25mm/m<sup>2</sup> × K).

**C404.4 Insulation of piping.** Piping from a water heater to the termination of the heated water fixture supply pipe shall be insulated in accordance with Table C403.12.3. On both the inlet and outlet piping of a storage water heater or heated water storage tank, the piping to a heat trap or the first 8 feet (2438 mm) of piping, whichever is less, shall be insulated. Piping that is heat traced shall be insulated in accordance with Table C403.12.3 or the heat trace manufacturer's instructions. Tubular pipe insulation shall be installed in accordance with the insulation manufacturer's instructions. Pipe insulation shall be continuous except where the piping passes through a framing member. The minimum insulation thickness requirements of this section shall not supersede any greater insulation thickness requirements necessary for the protection of piping from freezing temperatures or the protection of personnel against external surface temperatures on the insulation.

**Exception:** Tubular pipe insulation shall not be required on the following:

1. The tubing from the connection at the termination of the fixture supply piping to a plumbing fixture or plumbing appliance.
2. Valves, pumps, strainers and threaded unions in piping that is 1 inch (25 mm) or less in nominal diameter.
3. Piping from user-controlled shower and bath mixing valves to the water outlets.
4. Cold-water piping of a demand recirculation water system.
5. Tubing from a hot drinking-water heating unit to the water outlet.
6. Piping at locations where a vertical support of the piping is installed.
7. Piping surrounded by building insulation with a thermal resistance (R-value) of not less than R-3.

**TABLE C404.2  
MINIMUM PERFORMANCE OF WATER-HEATING EQUIPMENT**

EQUIPMENT TYPE	SIZE CATEGORY (input)	SUBCATEGORY OR RATING CONDITION	PERFORMANCE REQUIRED <sup>a, b</sup>	TEST PROCEDURE
Water heaters, electric	≤ 12 kW <sup>d</sup>	Tabletop <sup>c</sup> , ≥ 20 gallons and ≤ 120 gallons	0.93 – 0.00132V, EF	DOE 10 CFR Part 430
		Resistance ≥ 20 gallons and ≤ 55 gallons	0.960 – 0.0003V, EF	
		Grid-enabled <sup>f</sup> > 75 gallons and < 120 gallons	1.061 – 0.00168V, EF	
	> 12 kW	Resistance	(0.3 + 27/V <sub>m</sub> ) <sub>2</sub> %/h	ANSI Z21.10.3

	<u>&lt; 24 amps and &lt; 250 volts</u>	<u>Heat pump &gt; 55 gallons and ≤ 120 gallons</u>	<u>2.057 – 0.00113V, EF</u>	<u>DOE 10 CFR Part 430</u>
<u>Storage water heaters, gas</u>	<u>≤ 75,000 Btu/h</u>	<u>≥ 20 gallons and &gt; 55 gallons</u>	<u>0.675 – 0.0015V, EF</u>	<u>DOE 10 CFR Part 430</u>
		<u>≥ 55 gallons and ≤ 100 gallons</u>	<u>0.8012 – 0.00078V, EF</u>	
	<u>&gt; 75,000 Btu/h and &lt; 155,000 Btu/h</u>	<u>&lt; 4,000 Btu/h/gal</u>	$\frac{80\% E_t}{(Q/800 + 110\sqrt{V})SL, \text{ Btu/h}}$	<u>ANSI Z21.10.3</u>
	<u>&gt; 155,000 Btu/h</u>	<u>&lt; 4,000 Btu/h/gal</u>	$\frac{80\% E_t}{(Q/800 + 110\sqrt{V})SL, \text{ Btu/h}}$	
<u>Instantaneous water heaters, gas</u>	<u>≥ 50,000 Btu/h and &lt; 200,000 Btu/h<sup>e</sup></u>	<u>≥ 4,000 Btu/h/gal and &lt; 2 gal</u>	<u>0.82 – 0.00 19V, EF</u>	<u>DOE 10 CFR Part 430</u>
	<u>≥ 200,000 Btu/h</u>	<u>≥ 4,000 Btu/h/gal and &lt; 10 gal</u>	<u>80% E<sub>t</sub></u>	<u>ANSI Z21.10.3</u>
	<u>&gt; 200,000 Btu/h</u>	<u>≥ 4,000 Btu/h/gal and ≥ 10 gal</u>	$\frac{80\% E_t}{(Q/800 + 110\sqrt{V})SL, \text{ Btu/h}}$	
<u>Storage water heaters, oil</u>	<u>≤ 105,000 Btu/h</u>	<u>≥ 20 gal and ≤ 50 gallons</u>	<u>0.68 – 0.0019V, EF</u>	<u>DOE 10 CFR Part 430</u>
	<u>≥ 105,000 Btu/h</u>	<u>&lt; 4,000 Btu/h/gal</u>	$\frac{80\% E_t}{(Q/800 + 110\sqrt{V})SL, \text{ Btu/h}}$	<u>ANSI Z21.10.3</u>
<u>Instantaneous water heaters, oil</u>	<u>≤ 210,000 Btu/h</u>	<u>≥ 4,000 Btu/h/gal and &lt; 2 gal</u>	<u>0.59 – 0.0019V, EF</u>	<u>DOE 10 CFR Part 430</u>
	<u>&gt; 210,000 Btu/h</u>	<u>≥ 4,000 Btu/h/gal and &lt; 10 gal</u>	<u>80% E<sub>t</sub></u>	<u>ANSI Z21.10.3</u>
	<u>≥ 210,000 Btu/h</u>	<u>≥ 4,000 Btu/h/gal and ≥ 10 gal</u>	$\frac{78\% E_t}{(Q/800 + 110\sqrt{V})SL, \text{ Btu/h}}$	
<u>Hot water supply boilers, gas and oil</u>	<u>≥ 300,000 Btu/h and &lt; 12,500,000 Btu/h</u>	<u>≥ 4,000 Btu/h/gal and &lt; 10 gal</u>	<u>80% E<sub>t</sub></u>	<u>ANSI Z21.10.3</u>
<u>Hot water supply boilers, gas</u>	<u>≥ 300,000 Btu/h and &lt; 12,500,000 Btu/h</u>	<u>≥ 4,000 Btu/h/gal and ≥ 10 gal</u>	$\frac{80\% E_t}{(Q/800 + 110\sqrt{V})SL, \text{ Btu/h}}$	
<u>Hot water supply boilers, oil</u>	<u>≥ 300,000 Btu/h and &lt; 12,500,000 Btu/h</u>	<u>≥ 4,000 Btu/h/gal and ≥ 10 gal</u>	$\frac{78\% E_t}{(Q/800 + 110\sqrt{V})SL, \text{ Btu/h}}$	
<u>Pool heaters, gas and oil</u>	<u>All</u>	<u>=</u>	<u>82% E<sub>t</sub></u>	<u>ASHRAE 146</u>
<u>Heat pump pool heaters</u>	<u>All</u>	<u>=</u>	<u>4.0 COP</u>	<u>AHRI 1160</u>
<u>Unfired storage tanks</u>	<u>All</u>	<u>=</u>	<u>Minimum insulation requirement R-12.5 (h × ft<sup>2</sup> × °F)/Btu</u>	<u>(none)</u>

TABLE C404.2—continued

MINIMUM PERFORMANCE OF WATER-HEATING EQUIPMENT

For SI: 1 foot = 304.8 mm, 1 square foot = 0.0929 m<sup>2</sup>, °C = [(°F) – 32]/1.8, 1 British thermal unit per hour = 0.2931 W, 1 gallon = 3.785 L, 1 British thermal unit per hour per gallon = 0.078 W/L.

a. Energy factor (EF) and thermal efficiency (E<sub>t</sub>) are minimum requirements. In the EF equation, V is the rated volume in gallons.

- b. Standby loss (SL) is the maximum Btu/h based on a nominal 70°F temperature difference between stored water and ambient requirements. In the SL equation,  $Q$  is the nameplate input rate in Btu/h. In the equations for electric water heaters,  $V$  is the rated volume in gallons and  $V_m$  is the measured volume in gallons. In the SL equation for oil and gas water heaters and boilers,  $V$  is the rated volume in gallons.
- c. Instantaneous water heaters with input rates below 200,000 Btu/h shall comply with these requirements where the water heater is designed to heat water to temperatures 180°F or higher.
- d. Electric water heaters with an input rating of 12 kW (40,950 Btu/h) or less that are designed to heat water to temperatures of 180°F or greater shall comply with the requirements for electric water heaters that have an input rating greater than 12 kW (40,950 Btu/h).
- e. A tabletop water heater is a water heater that is enclosed in a rectangular cabinet with a flat top surface not more than 3 feet in height.
- f. A grid-enabled water heater is an electric-resistance water heater that meets all of the following:
  - 1. Has a rated storage tank volume of more than 75 gallons.
  - 2. Was manufactured on or after April 16, 2015.
  - 3. Is equipped at the point of manufacture with an activation lock.
  - 4. Bears a permanent label applied by the manufacturer that complies with all of the following:
    - 4.1. Is made of material not adversely affected by water.
    - 4.2. Is attached by means of nonwater-soluble adhesive.
    - 4.3. Advises purchasers and end users of the intended and appropriate use of the product with the following notice printed in 16.5 point Arial Narrow Bold font: "IMPORTANT INFORMATION: This water heater is intended only for use as part of an electric thermal storage or demand response program. It will not provide adequate hot water unless enrolled in such a program and activated by your utility company or another program operator. Confirm the availability of a program in your local area before purchasing or installing this product."

**C404.5 Efficient Heated water supply piping.** ~~Deleted.~~ Water supply piping shall be in accordance with Section C404.5.1 or C404.5.2. The flow rate through 1/4-inch (6.4 mm) piping shall be not greater than 0.5 gpm (1.9 L/m). The flow rate through 5/16-inch (7.9 mm) piping shall be not greater than 1 gpm (3.8 L/m). The flow rate through 3/8-inch (9.5 mm) piping shall be not greater than 1.5 gpm (5.7 L/m).

**C404.5.1 Maximum allowable pipe length method.** The maximum allowable piping length from the nearest source of heated water to the termination of the fixture supply pipe shall be in accordance with the following. Where the piping contains more than one size of pipe, the largest size of pipe within the piping shall be used for determining the maximum allowable length of the piping in Table C404.5.1.

- 1. For a public lavatory faucet, use the "Public lavatory faucets" column in Table C404.5.1.
- 2. For all other plumbing fixtures and plumbing appliances, use the "Other fixtures and appliances" column in Table C404.5.1.

**TABLE C404.5.1  
PIPING VOLUME AND MAXIMUM PIPING LENGTHS**

NOMINAL PIPE SIZE (inches)	VOLUME (liquid ounces per foot length)	MAXIMUM PIPING LENGTH (feet)	
		Public lavatory faucets	Other fixtures and appliances
1/4	0.33	50	50
5/16	0.5	4	
3/8	0.75	3	50
1/2	1.5	43	32
5/8	2	1	
3/4	0.5	21	16
7/8	4	0.5	
1	5	0.5	13
1 1/4	8	0.5	8
1 1/2	11	0.5	6

2 or larger	18	0.5	4
-------------	----	-----	---

For SI: 1 inch = 25.4 mm, 1 foot = 304.8 mm, 1 liquid ounce = 0.030 L,  
1 gallon = 128 ounces.

**C404.5.2 Maximum allowable pipe volume method.** The water volume in the piping shall be calculated in accordance with Section C404.5.2.1. Water heaters, circulating water systems and heat trace temperature maintenance systems shall be considered to be sources of heated water.

The volume from the nearest source of heated water to the termination of the fixture supply pipe shall be as follows:

1. For a public lavatory faucet: not more than 2 ounces (0.06 L).
2. For other plumbing fixtures or plumbing appliances; not more than 0.5 gallon (1.89 L).

**C404.5.2.1 Water volume determination.** The volume shall be the sum of the internal volumes of pipe, fittings, valves, meters and manifolds between the nearest source of heated water and the termination of the fixture supply pipe. The volume in the piping shall be determined from the “Volume” column in Table C404.5.1 or from Table C404.5.2.1. The volume contained within fixture shutoff valves, within flexible water supply connectors to a fixture fitting and within a fixture fitting shall not be included in the water volume determination. Where heated water is supplied by a recirculating system or heat-traced piping, the volume shall include the portion of the fitting on the branch pipe that supplies water to the fixture.

**TABLE C404.5.2.1  
INTERNAL VOLUME OF VARIOUS WATER DISTRIBUTION TUBING**

OUNCES OF WATER PER FOOT OF TUBE									
Nominal Size (inches)	Copper Type M	Copper Type L	Copper Type K	CPVC CTS SDR 11	CPVC SCH 40	CPVC SCH 80	PE-RT SDR	Composite ASTM F1281	PEX CTS SDR 9
3/8	1.06	0.97	0.84	N/A	1.17	—	0.64	0.63	0.64
1/2	1.69	1.55	1.45	1.25	1.89	1.46	1.18	1.31	1.18
3/4	3.43	3.22	2.90	2.67	3.38	2.74	2.35	3.39	2.35
1	5.81	5.49	5.17	4.43	5.53	4.57	3.91	5.56	3.91
1 1/4	8.70	8.36	8.09	6.61	9.66	8.24	5.81	8.49	5.81
1 1/2	12.18	11.83	11.45	9.22	13.20	11.38	8.09	13.88	8.09
2	21.08	20.58	20.04	15.79	21.88	19.11	13.86	21.48	13.86

For SI: 1 foot = 304.8 mm, 1 inch = 25.4 mm, 1 liquid ounce = 0.030 L, 1 oz/ft<sup>2</sup> = 305.15 g/m<sup>2</sup>.  
N/A = Not Available.

~~**C404.6 Hot water system controls.** Automatic circulating hot water system pumps or heat trace shall be arranged to be conveniently turned off automatically or manually when the hot water system is not in operation.~~

**C404.6 Heated-water circulating and temperature maintenance systems.** Heated-water circulation systems shall be in accordance with Section C404.6.1. Heat trace temperature maintenance systems shall be in accordance with Section C404.6.2. Controls for hot water storage shall be in accordance with Section C404.6.3. Automatic controls, temperature sensors and pumps shall be in a location with *access*. Manual controls shall be in a location with *ready access*.

**C404.6.1 Circulation systems.** Heated-water circulation systems shall be provided with a circulation pump. The system return pipe shall be a dedicated return pipe or a cold water supply pipe. Gravity and thermo-syphon circulation systems shall be prohibited. Controls for circulating hot water system pumps shall automatically turn off the pump when the water in the circulation loop is at the desired temperature and when there is not a demand for hot water. The controls shall limit the temperature of the water entering the cold water piping to not greater than 104°F (40°C).

~~**C404.7 Demand recirculation controls.** Deleted.~~

**\*\* C404.6.1.1 Demand recirculation controls.** Demand recirculation water systems shall have controls that start the pump upon receiving a signal from the action of a user of a fixture or appliance, sensing the presence of a user of a fixture, or sensing the flow of hot or tempered water to a fixture fitting or appliance.

**C404.6.2 Heat trace systems.** Electric heat trace systems shall comply with IEEE 515.1. Controls for such systems shall be able to automatically adjust the energy input to the heat tracing to maintain the desired water temperature in the piping in accordance with the times when heated water is used in the occupancy. Heat trace shall be arranged to be turned off automatically when there is not a demand for hot water.

**C404.6.3 Controls for hot water storage.** The controls on pumps that circulate water between a water heater and a heated-water storage tank shall limit operation of the pump from heating cycle startup to not greater than 5 minutes after the end of the cycle.

~~C404.8 Drain water heat recovery units. Deleted.~~

~~C404.8 C404.7 Drain water heat recovery units.~~ Drain water heat recovery units shall comply with CSA B55.2. Potable water-side pressure loss shall be less than 10 psi (69 kPa) at maximum design flow. For *Group R* occupancies, the efficiency of drain water heat recovery unit efficiency shall be in accordance with CSA B55.1.

~~C404.10 Energy consumption of portable spas (Mandatory). Deleted.~~

**C404.10 C404.8 Energy consumption of pools and permanent spas.** The energy consumption of pools and permanent spas shall be controlled by the requirements in Sections C404.8.1 through C404.8.3.

**C404.8.1 Heaters.** The electric power to all heaters shall be controlled by an on-off switch that is an integral part of the heater, mounted on the exterior of the heater, or external to and within 3 feet (914 mm) of the heater in a location with *ready access*. Operation of such switch shall not change the setting of the heater thermostat. Such switches shall be in addition to a circuit breaker for the power to the heater. Gas-fired heaters shall not be equipped with continuously burning ignition pilots.

~~C404.9.2 Time switches.~~ Time switches or other control methods that can automatically turn off and on heaters and pump motors according to a preset schedule shall be installed for heaters and pump motors. Heaters and pump motors that have built-in time switches shall be in compliance with this section.

**Exceptions:**

- ~~1. Where public health standards require 24-hour pump operation.~~
- ~~2. Pumps that operate solar- and waste-heat-recovery pool heating systems.~~

**C404.8.2 Time switches.** Time switches or other control methods that can automatically turn off and on heaters and pump motors according to a preset schedule shall be installed for heaters and pump motors. Heaters and pump motors that have built-in time switches shall be in compliance with this section.

**Exceptions:**

1. Where public health standards require 24-hour pump operation.
2. Pumps that operate solar- and waste-heat-recovery pool heating systems.

**C404.9.3 C404.8.3 Covers.** Outdoor heated pools and outdoor permanent spas shall be provided with a class 1 vapor-retardant cover or other *approved* vapor-retardant means.

**Exception:** Pools deriving over 70 percent of the energy from heating from *site recovered energy* or *solar energy source*.

**Exception:** Where more than 75 percent of the energy for heating, computed over an operating season of not fewer than 3 calendar months, is from a heat pump or an on-site renewable energy system, covers or other vapor-retardant means shall not be required.

C404.9 Portable spas. The energy consumption of electric-powered portable spas shall be controlled by the requirements of APSP 14.

## SECTION C405 ELECTRICAL POWER AND LIGHTING SYSTEMS

**C405.1 General (Mandatory).** This section covers lighting system controls, the maximum lighting power for interior and exterior applications and electrical energy consumption.

**Exception:** Dwelling units within commercial buildings shall not be required to comply with Sections C405.2 through C405.5, provided that they comply with Section R404.1.

**C405.1 General.** Lighting system controls, the maximum lighting power for interior and exterior applications, and electrical energy consumption shall comply with this section. *Sleeping units* shall comply with Section C405.2.4 and with either Section C405.1.1 or C405.3. *General lighting* shall consist of all lighting included when calculating the total connected interior lighting power in accordance with Section C405.3.1 and which does not require specific application controls in accordance with Section C405.2.4.

Transformers, uninterruptable power supplies, motors and electrical power processing equipment in data center systems shall comply with Section 8 of ASHRAE 90.4 in addition to this code.

**C405.1.1 Lighting for dwelling units.** No less than 90 percent of the permanently installed lighting serving dwelling units, excluding kitchen appliance lighting, shall be provided by lamps with an efficacy of not less than 65 lm/W or luminaires with an efficacy of not less than 45 lm/W, or shall comply with Sections C405.2.4 and C405.3.

**C405.2 Lighting controls (Mandatory).** Lighting systems shall be provided with controls as specified in Sections C405.2.1, C405.2.2, C405.2.3, C405.2.4 and C405.2.5.

**C405.2 Lighting controls.** Lighting systems shall be provided with controls that comply with one of the following.

1. Lighting controls as specified in Sections C405.2.1 through C405.2.7.
2. Luminaire level lighting controls (LLLC) and lighting controls as specified in Sections C405.2.1, C405.2.5 and C405.2.6.  
The LLLC luminaire shall be independently capable of:
  - 2.1. Monitoring occupant activity to brighten or dim lighting when occupied or unoccupied, respectively.
  - 2.2. Monitoring ambient light, both electric light and daylight, and brighten or dim artificial light to maintain desired light level.
  - 2.3. For each control strategy, configuration and reconfiguration of performance parameters including; bright and dim setpoints, timeouts, dimming fade rates, sensor sensitivity adjustments, and wireless zoning configurations.

**Exceptions:** Lighting controls are not required for the following:

1. Areas designated as security or emergency areas that are required to be continuously lighted.
2. Interior exit stairways, interior exit ramps and exit passageways.
3. Emergency egress lighting that is normally off.

**C405.2.1 Occupant sensor controls.** Occupant *sensor controls* shall be installed to control lights in the following space types:

1. Classrooms/lecture/training rooms.
2. Conference/meeting/multipurpose rooms.
3. Copy/print rooms.
4. ~~Lounges.~~
5. ~~Employee lunch and break rooms.~~
6. ~~Private offices.~~
4. Lounges/breakrooms.
5. Enclosed offices.

6. Open plan office areas.
7. Restrooms.
8. Storage rooms, ~~greater than 100 square feet.~~
- ~~9. Janitorial closets.~~
- ~~10. Computer server rooms.~~
- ~~11. Mechanical and electrical equipment rooms.~~
- ~~12. Warehouses.~~
9. Locker rooms.
10. Corridors.
11. Warehouse storage areas.
12. Other spaces 300 square feet (28 m<sup>2</sup>) or less that are enclosed by floor-to-ceiling height partitions.

Occupancy sensors shall not be required for:

1. Rooms requiring explosion proof electrical devices.
- ~~2. Chemical storage rooms.~~

**Exception:** Luminaires that are required to have specific application controls in accordance with Section C405.2.5.

**~~C405.2.1.1 Occupant sensor control function.~~** ~~Occupant sensor controls in spaces other than warehouses specified in Section C405.2.1 shall comply with the following:~~

1. Automatically turn off lights within 30 minutes of all occupants leaving the space.
- ~~2. Deleted.~~
- ~~3. Shall incorporate a *manual control* to allow occupants to turn lights off.~~

**C405.2.1.1 Occupant sensor control function.** Occupant sensor controls in warehouses shall comply with Section C405.2.1.2. Occupant sensor controls in open plan office areas shall comply with Section C405.2.1.3. Occupant sensor controls in corridors shall comply with Section C405.2.1.4. Occupant sensor controls for all other spaces specified in Section C405.2.1 shall comply with the following:

1. They shall automatically turn off lights within 20 minutes after all occupants have left the space.
2. They shall be manual on or controlled to automatically turn on the lighting to not more than 50-percent power.
3. They shall incorporate a manual control to allow occupants to turn off lights.

**Exception:** Full automatic-on controls with no manual control shall be permitted in corridors, interior parking areas, stairways, restrooms, locker rooms, lobbies, library stacks and areas where manual operation would endanger occupant safety or security.

**~~C405.2.1.2 Occupant sensor control function in warehouses.~~** ~~In warehouses, the lighting in aisleways and open areas shall be controlled with occupant sensors that automatically reduce lighting power from 50 percent to 100 percent off when the areas are unoccupied. The occupant sensors shall control lighting in each aisleway independently and shall not control lighting beyond the aisleway being controlled by the sensor.~~

**C405.2.1.2 Occupant sensor control function in warehouse storage areas.** Lighting in warehouse storage areas shall be controlled as follows:

1. Lighting in each aisleway shall be controlled independently of lighting in all other aisleways and open areas.
2. Occupant sensors shall automatically reduce lighting power within each controlled area to an occupied setpoint of not more than 50 percent within 20 minutes after all occupants have left the controlled area.
3. Lights that are not turned off by occupant sensors shall be turned off by time-switch control complying with Section C405.2.2.1.
4. A manual control shall be provided to allow occupants to turn off lights in the space.



**C405.2.1.3 Occupant sensor control function in open plan office areas.** Occupant sensor controls in open plan office spaces less than 300 square feet (28 m<sup>2</sup>) in area shall comply with Section C405.2.1.1. Occupant sensor controls in all other open plan office spaces shall comply with all of the following:

1. The controls shall be configured so that general lighting can be controlled separately in control zones with floor areas not greater than 600 square feet (55 m<sup>2</sup>) within the open plan office space.
2. General lighting in each control zone shall be permitted to automatically turn on upon occupancy within the control zone. General lighting in other unoccupied zones within the open plan office space shall be permitted to turn on to not more than 20 percent of full power or remain unaffected.
3. The controls shall automatically turn off general lighting in all control zones within 20 minutes after all occupants have left the open plan office space.

**Exception:** Where general lighting is turned off by time-switch control complying with Section C405.2.2.1.

4. General lighting in each control zone shall turn off or uniformly reduce lighting power to an unoccupied setpoint of not more than 20 percent of full power within 20 minutes after all occupants have left the control zone. □

**C405.2.1.4 Occupant sensor control function in corridors.** Occupant sensor controls in corridors shall uniformly reduce lighting power to not more than 50 percent of full power within 20 minutes after all occupants have left the space.

**Exception:** Corridors provided with less than two footcandles of illumination on the floor at the darkest point with all lights on.

**C405.2.2 Time-switch controls.** Each area of the building that is not provided with *occupant sensor controls* complying with Section C405.2.1.1 shall be provided with *time-switch controls* complying with Section C405.2.2.1.

**Exceptions:**

1. Luminaires that are required to have specific application controls in accordance with Section C405.2.4.
2. Spaces where patient care is directly provided.
3. Spaces where an automatic shutoff would endanger occupant safety or security.
4. Lighting intended for continuous operation.
5. Shop and laboratory classrooms.

**C405.2.2.1 Time switch control function.** Each space provided with *time switch controls* shall also be provided with a *manual control* for light reduction in accordance with Section C405.2.2.2. *Time switch controls* shall include an override switching device that complies with the following:

1. Have a minimum 7 day clock.
2. Be capable of being set for seven different day types per week.
3. Incorporate an automatic holiday “shutoff” feature, which turns off all controlled lighting loads for at least 24 hours and then resumes normally scheduled operations.
4. Have program backup capabilities, which prevent the loss of program and time settings for at least 10 hours, if power is interrupted.
5. Include an override switch that complies with the following:
  - 5.1. The override switch shall be a manual control.
  - 5.2. The override switch, when initiated, shall permit the controlled lighting to remain on for not more than 2 hours.
  - 5.3. Any individual override switch shall control the lighting for an area not larger than 5,000 square feet (465 m<sup>2</sup>).

**Exceptions:**

1. Within malls, arcades, auditoriums, singletenant retail spaces, industrial facilities and arenas:
  - 1.1. The time limit shall be permitted to be greater than 2 hours, provided that the override switch is a captive key device.
  - 1.2. The area controlled by the override switch is permitted to be greater than 5,000 square feet (465 m<sup>2</sup>), but shall not be greater than 20,000 square feet (1860 m<sup>2</sup>).
2. Where provided with *manual control*, the following areas are not required to have light reduction control in accordance with Section C405.2.2.2:
  - 2.1. Spaces that have only one luminaire with a rated power of less than 100 watts.
  - 2.2. Spaces that use less than 0.6 watts per square foot (6.5 W/m<sup>2</sup>).
  - 2.3. Corridors, equipment rooms, public lobbies, electrical or mechanical rooms.

**C405.2.2.1 Time-switch control function.** Time-switch *controls* shall comply with all of the following:

1. Automatically turn off lights when the space is scheduled to be unoccupied.
2. Have a minimum 7-day clock.
3. Be capable of being set for seven different day types per week.
4. Incorporate an automatic holiday “shutoff” feature, which turns off all controlled lighting loads for not fewer than 24 hours and then resumes normally scheduled operations.
5. Have program backup capabilities, which prevent the loss of program and time settings for not fewer than 10 hours, if power is interrupted.
6. Include an override switch that complies with the following:
  - 6.1. The override switch shall be a manual control.
  - 6.2. The override switch, when initiated, shall permit the controlled lighting to remain on for not more than 2 hours.
  - 6.3. Any individual override switch shall control the lighting for an area not larger than 5,000 square feet (465 m<sup>2</sup>).

**Exception:** Within mall concourses, auditoriums, sales areas, manufacturing facilities and sports arenas:

1. The time limit shall be permitted to be greater than 2 hours, provided that the switch is a captive key device.
2. The area controlled by the override switch shall not be limited to 5,000 square feet (465 m<sup>2</sup>) provided that such area is less than 20,000 square feet (1860 m<sup>2</sup>). \*

**C405.2.2.2 Light reduction controls.** Spaces required to have light reduction controls shall have a *manual control* that allows the occupant to reduce the connected lighting load in a reasonably uniform illumination pattern by at least 50 percent. Lighting reduction shall be achieved by one of the following or another approved method:

1. Controlling all lamps or luminaires.
2. Dual switching of alternate rows of luminaires, alternate luminaires or alternate lamps.
3. Switching the middle lamp luminaires independently of the outer lamps.
4. Switching each luminaire or each lamp.

~~Exception: Light reduction controls are not required in daylight zones with daylight responsive controls.~~

~~C405.2.3 Daylight responsive controls. Deleted.~~

**\*\*** **C405.2.4 Daylight-responsive controls.** *Daylight-responsive controls* complying with Section C405.2.4.1 shall be provided to control the general lighting within *daylight zones* in the following spaces:

1. Spaces with a total of more than 150 watts of *general lighting* within primary sidelit daylight zones complying with Section C405.2.4.2.
2. Spaces with a total of more than 300 watts of *general lighting* within sidelit daylight zones complying with Section C405.2.4.2.
3. Spaces with a total of more than 150 watts of *general lighting* within toplit daylight zones complying with Section C405.2.4.3.

**Exceptions:** Daylight responsive controls are not required for the following:

1. Spaces in health care facilities where patient care is directly provided.
2. Sidelit daylight zones on the first floor above grade in Group A-2 and Group M occupancies.
3. New buildings where the total connected lighting power calculated in accordance with Section C405.3.1 is not greater than the adjusted interior lighting power allowance ( $LPA_{adj}$ ) calculated in accordance with Equation 4-9.

$$LPA_{adj} = [LPA_{norm} \times (1.0 - 0.4 \times UDZFA / TBFA)] \quad \text{(Equation 4-9)}$$

where:

$LPA_{adj}$  = Adjusted building interior lighting power allowance in watts.

$LPA_{norm}$  = Normal building lighting power allowance in watts calculated in accordance with Section C405.3.2 and reduced in accordance with Section C406.3 where Option 2 of Section C406.1 is used to comply with the requirements of Section C406.

$UDZFA$  = Uncontrolled daylight zone floor area is the sum of all sidelit and toplit zones, calculated in accordance with Sections C405.2.4.2 and C405.2.4.3, that do not have daylight responsive controls.

$TBFA$  = Total building floor area is the sum of all floor areas included in the lighting power allowance calculation in Section C405.3.2.

~~C405.2.3.1 Daylight responsive control function. Deleted.~~

**C405.2.4.1 Daylight-responsive control function.** Where required, *daylight-responsive controls* shall be provided within each space for control of lights in that space and shall comply with all of the following:

1. Lights in *toplit daylight zones* in accordance with Section C405.2.4.3 shall be controlled independently of lights in sidelit daylight zones in accordance with Section C405.2.4.2.
2. Lights in the primary sidelit daylight zone shall be controlled independently of lights in the secondary sidelit daylight zone.
3. *Daylight responsive controls* within each space shall be configured so that they can be calibrated from within that space by authorized personnel.
4. Calibration mechanisms shall be in a location with *ready access*.
5. *Daylight responsive controls* shall dim lights continuously from full light output to 15 percent of full light output or lower.
6. *Daylight responsive controls* shall be configured to completely shut off all controlled lights.
7. When occupant sensor controls have reduced the lighting power to an unoccupied setpoint in accordance with Sections C405.2.1.2 through C405.2.1.4, daylight responsive controls shall continue to adjust electric light levels in

response to available daylight, but shall be configured to not increase the lighting power above the specified unoccupied setpoint.

8. Lights in *sidelit daylight zones* in accordance with Section C405.2.4.2 facing different cardinal orientations [within 45 degrees (0.79 rad) of due north, east, south, west] shall be controlled independently of each other.

**Exceptions:**

1. Within each space, up to 150 watts of lighting within the primary *sidelit daylight zone* is permitted to be controlled together with lighting in a primary *sidelit daylight zone* facing a different cardinal orientation.
2. Within each space, up to 150 watts of lighting within the secondary *sidelit daylight zone* is permitted to be controlled together with lighting in a secondary *sidelit daylight zone* facing a different cardinal orientation.

**C405.2.3.2 Sidelight daylight zone.** Deleted.

**C405.2.4.2 Sidelit daylight zone.** The *sidelit daylight zone* is the floor area adjacent to vertical *fenestration* that complies with all of the following:

1. Where the fenestration is located in a wall, the *sidelit daylight zone* shall extend laterally to the nearest full-height wall, or up to 1.0 times the height from the floor to the top of the fenestration, and longitudinally from the edge of the fenestration to the nearest full-height wall, or up to 0.5 times the height from the floor to the top of the fenestration, whichever is less, as indicated in Figure C405.2.4.2(1).
2. Where the fenestration is located in a rooftop monitor, the *sidelit daylight zone* shall extend laterally to the nearest obstruction that is taller than 0.7 times the ceiling height, or up to 1.0 times the height from the floor to the bottom of the fenestration, whichever is less, and longitudinally from the edge of the fenestration to the nearest obstruction that is taller than 0.7 times the ceiling height, or up to 0.25 times the height from the floor to the bottom of the fenestration, whichever is less, as indicated in Figures C405.2.4.2(2) and C405.2.4.2(3).
3. The secondary *sidelit daylight zone* is directly adjacent to the primary *sidelit daylight zone* and shall extend laterally to 2.0 times the height from the floor to the top of the fenestration or to the nearest full height wall, whichever is less, and longitudinally from the edge of the fenestration to the nearest full height wall, or up to 2 feet, whichever is less, as indicated in Figure C405.2.4.2(1).
4. The area of the fenestration is not less than 24 square feet (2.23 m<sup>2</sup>).
5. The distance from the fenestration to any building or geological formation that would block *access to* daylight is greater than one-half of the height from the bottom of the fenestration to the top of the building or geologic formation.
6. The visible transmittance of the fenestration is not less than 0.20.
7. The projection factor (determined in accordance with Equation 4-5) for any overhanging projection that is shading the fenestration is not greater than 1.0 for fenestration oriented 45 degrees or less from true north and not greater than 1.5 for all other orientations.

**C405.2.3.3 Toplight daylight zone.** Deleted.

**C405.2.4.3 Toplit daylight zone.** The *toplit daylight zone* is the floor area underneath a roof fenestration assembly that complies with all of the following:

1. The *toplit daylight zone* shall extend laterally and longitudinally beyond the edge of the roof fenestration assembly to the nearest obstruction that is taller than 0.7 times the ceiling height, or up to 0.7 times the ceiling height, whichever is less, as indicated in Figure C405.2.4.3. □
2. Direct sunlight is not blocked from hitting the roof fenestration assembly at the peak solar angle on the summer solstice by buildings or geological formations.
3. The product of the visible transmittance of the roof fenestration assembly and the area of the rough opening of the roof fenestration assembly divided by the area of the *toplit zone* is not less than 0.008.

**C405.2.4.4 Atriums.** Daylight zones at atrium spaces shall be established at the top floor surrounding the atrium and at the floor of the atrium space, and not on intermediate floors, as indicated in Figure C405.2.4.4

**FIGURE C405.2.4.2(1)  
PRIMARY AND SECONDARY SIDELIT DAYLIGHT ZONES**

(No image was provided – images from webpage)

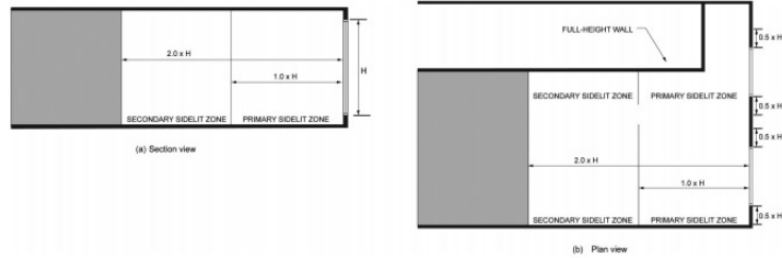

FIGURE C405.2.4.2(1) PRIMARY AND SECONDARY SIDELIT DAYLIGHT ZONES

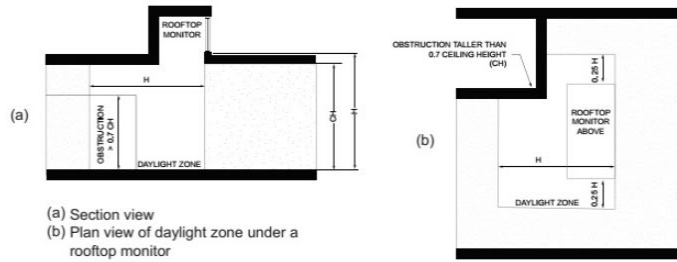

FIGURE C405.2.4.2(2) DAYLIGHT ZONE UNDER A ROOFTOP MONITOR

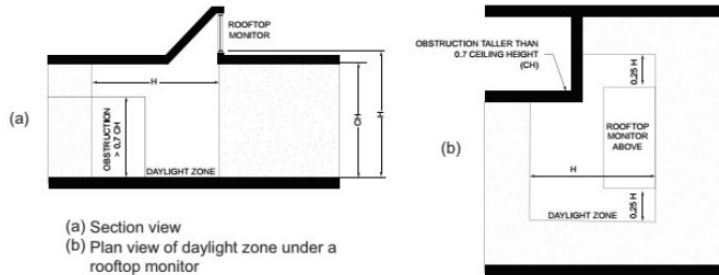

FIGURE C405.2.4.2(3) DAYLIGHT ZONE UNDER A SLOPED ROOFTOP MONITOR

**C405.2.4 Specific application controls.** Specific application controls shall be provided for the following:

1. Display and accent light shall be controlled by a dedicated control that is independent of the controls for other lighting within the room or space.
2. Lighting in cases used for display case purposes shall be controlled by a dedicated control that is independent of the controls for other lighting within the room or space.
3. Hotel and motel sleeping units and guest suites shall have a master control device that is capable of automatically switching off all installed luminaires and switched receptacles within 20 minutes after all occupants leave the room.

**Exception:** Lighting and switched receptacles controlled by captive key systems.

4. Supplemental task lighting, including permanently installed under-shelf or under-cabinet lighting, shall have a control device integral to the luminaires or be controlled by a wall-mounted control device provided that the control device is readily accessible.

5. Lighting for nonvisual applications, such as plant growth and food warming, shall be controlled by a dedicated control that is independent of the controls for other lighting within the room or space.

6. Lighting equipment that is for sale or for demonstrations in lighting education shall be controlled by a dedicated control that is independent of the controls for other lighting within the room or space.

**C405.2.5 Specific application controls.** Specific application controls shall be provided for the following:

1. The following lighting shall be controlled by an occupant sensor complying with Section C405.2.1.1 or a time-switch control complying with Section C405.2.2.1. In addition, a manual control shall be provided to control such lighting separately from the general lighting in the space:

1.1. Luminaires for which additional lighting power is claimed in accordance with Section C405.3.2.2.1.

1.2. Display and accent.

1.3. Lighting in display cases.

1.4. Supplemental task lighting, including permanently installed under-shelf or under-cabinet lighting.

1.5. Lighting equipment that is for sale or demonstration in lighting education.

1.6. Display lighting for exhibits in galleries, museums and monuments that is in addition to *general lighting*.

2. *Sleeping units* shall have control devices or systems that are configured to automatically switch off all permanently installed luminaires and switched receptacles within 20 minutes after all occupants have left the unit.

**Exceptions:**

1. Lighting and switched receptacles controlled by card key controls.

2. Spaces where patient care is directly provided.

3. Permanently installed luminaires within *dwelling units* shall be provided with controls complying with Section C405.2.1.1 or C405.2.3.1.

4. Lighting for nonvisual applications, such as plant growth and food warming, shall be controlled by a time switch control complying with Section C405.2.2.1 that is independent of the controls for other lighting within the room or space.

5. Task lighting for medical and dental purposes that is in addition to *general lighting* shall be provided with a *manual control*.

**C405.2.2.3 Manual controls.** ~~Manual controls for lights shall comply with the following:~~

1. ~~Shall be readily accessible to occupants.~~

2. ~~Shall be located where the controlled lights are visible, or shall identify the area served by the lights and indicate their status.~~

**C405.2.6 Manual controls.** Where required by this code, manual controls for lights shall comply with the following:

1. They shall be in a location with *ready access* to occupants.

2. They shall be located where the controlled lights are visible, or shall identify the area served by the lights and indicate their status.

**C405.2.5 Exterior lighting controls.** Lighting not designated for dusk to dawn operation shall be controlled by either a combination of a photosensor and a time switch, or an astronomical time switch. Lighting designated for dusk to dawn operation shall be controlled by an astronomical time switch or photosensor. All time switches shall be capable of retaining programming and the time setting during loss of power for a period of at least 10 hours.

**C405.2.7 Exterior lighting controls.** Exterior lighting systems shall be provided with controls that comply with Sections C405.2.7.1 through C405.2.7.4.

**Exceptions:**

1. Lighting for covered vehicle entrances and exits from buildings and parking structures where required for eye adaptation.
2. Lighting controlled from within dwelling units.

**C405.2.7.1 Daylight shutoff.** Lights shall be automatically turned off when daylight is present and satisfies the lighting needs.

**C405.2.7.2 Building and landscape lighting.** Building and landscape lighting shall automatically shut off from not later than 1 hour after business closing to not earlier than 1 hour before business opening.

**C405.2.7.3 Lighting setback.** Lighting that is not controlled in accordance with Section C405.2.7.2 shall comply with the following:

1. Be controlled so that the total wattage of such lighting is automatically reduced by not less than 50 percent by selectively switching off or dimming luminaires at one of the following times:
  - 1.1. From not later than midnight to not earlier than 6 a.m.
  - 1.2. From not later than one hour after business closing to not earlier than one hour before business opening.
  - 1.3. During any time where activity has not been detected for 15 minutes or more.
2. Luminaires serving outdoor parking areas and having a rated input wattage of greater than 78 watts and a mounting height of 24 feet (7315 mm) or less above the ground shall be controlled so that the total wattage of such lighting is automatically reduced by not less than 50 percent during any time where activity has not been detected for 15 minutes or more. Not more than 1,500 watts of lighting power shall be controlled together. □

**C405.2.7.4 Exterior time-switch control function.** Time-switch controls for exterior lighting shall comply with the following:

1. They shall have a clock capable of being programmed for not fewer than 7 days.
2. They shall be capable of being set for seven different day types per week.
3. They shall incorporate an automatic holiday setback feature.
4. They shall have program backup capabilities that prevent the loss of program and time settings for a period of not less than 10 hours in the event that power is interrupted.

**C405.2.8 Parking garage lighting control.** Parking garage lighting shall be controlled by an *occupant sensor* complying with Section C405.2.1.1 or a *time-switch control* complying with Section C405.2.2.1. Additional lighting controls shall be provided as follows:

1. Lighting power of each luminaire shall be automatically reduced by not less than 30 percent when there is no activity detected within a lighting zone for 20 minutes. Lighting zones for this requirement shall be not larger than 3,600 square feet (334.5 m<sup>2</sup>).

**Exception:** Lighting zones provided with less than 1.5 footcandles of illumination on the floor at the darkest point with all lights on are not required to have automatic light-reduction controls.

2. Where lighting for eye adaptation is provided at covered vehicle entrances and exits from buildings and parking structures, such lighting shall be separately controlled by a device that automatically reduces lighting power by at least 50 percent from sunset to sunrise.

3. The power to luminaires within 20 feet (6096 mm) of perimeter wall openings shall automatically reduce in response to daylight by at least 50 percent.

**Exceptions:**

1. Where the opening-to-wall ratio is less than 40 percent as viewed from the interior and encompassing the vertical distance from the driving surface to the lowest structural element.
2. Where the distance from the opening to any exterior daylight blocking obstruction is less than one-half the height from the bottom of the opening or fenestration to the top of the obstruction.
3. Where openings are obstructed by permanent screens or architectural elements restricting daylight entering the interior space.

~~€405.3 Exit signs (Mandatory). Internally illuminated exit signs shall not be more than 5 watts per side.~~

~~€405.4 C405.3 Interior lighting power requirements. (Prescriptive). A building complies with this section where its total connected interior lighting power calculated under Section €405.4.1 C405.3.1 is not greater than the interior lighting power allowance calculated under Section €405.4.2 C405.3.2.~~

~~€405.4.1 C405.3.1 Total connected interior lighting power. The total connected interior lighting power shall be determined in accordance with Equation 4-9 4-10.~~

~~$TCLP = [SL + LV + LTPB + \text{Other}]$  (Equation 4-9)~~

~~where:~~

~~$TCLP$  = Total connected lighting power (watts).~~

~~$SL$  = Labeled wattage of luminaires for screw-in lamps.~~

~~$LV$  = Wattage of the transformer supplying low-voltage lighting.~~

~~$LTPB$  = Wattage of line-voltage lighting tracks and plug-in busways as the specified wattage of the luminaires, but at least 30 W/lin. ft. (100 W/lin m), or the wattage limit of the system's circuit breaker, or the wattage limit of other permanent current-limiting devices on the system.~~

~~$\text{Other}$  = The wattage of all other luminaires and lighting sources not covered previously and associated with interior lighting verified by data supplied by the manufacturer or other approved sources.~~

~~$TCLP = [LVL + BLL + LED + TRK + \text{Other}]$~~

~~(Equation 4-10)~~

~~where:~~

~~$TCLP$  = Total connected lighting power (watts).~~

~~$LVL$  = For luminaires with lamps connected directly to building power, such as line voltage lamps, the rated wattage of the lamp.~~

~~$BLL$  = For luminaires incorporating a ballast or transformer, the rated input wattage of the ballast or transformer when operating that lamp.~~

~~$LED$  = For light-emitting diode luminaires with either integral or remote drivers, the rated wattage of the luminaire.~~

~~$TRK$  = For lighting track, cable conductor, rail conductor, and plug-in busway systems that allow the addition and relocation of luminaires without rewiring, the wattage shall be one of the following:~~

1. The specified wattage of the luminaires, but not less than 8 W per linear foot (25 W/lin m).
2. The wattage limit of the permanent current-limiting devices protecting the system.



3. The wattage limit of the transformer supplying the system.

Other = The wattage of all other luminaires and lighting sources not covered previously and associated with interior lighting verified by data supplied by the manufacturer or other *approved* sources.

**Exceptions:**

1. ~~The connected power associated with the following lighting equipment is not included in calculating total connected lighting power.~~
  - 1.1. ~~Professional sports arena playing field lighting.~~
  - 1.2. ~~Lighting in sleeping units, provided that the lighting complies with Section R404.1.~~
  - 1.3. ~~Emergency lighting automatically off during normal building operation.~~
  - 1.4. ~~Lighting in spaces specifically designed for use by occupants with special lighting needs, including those with visual impairment and other medical and age-related issues.~~
  - 1.5. ~~Lighting in interior spaces that have been specifically designated as a registered interior historic landmark.~~
  - 1.6. ~~Casino gaming areas.~~
  - 1.7. ~~Mirror lighting in dressing rooms.~~
2. ~~Lighting equipment used for the following shall be exempt provided that it is in addition to general lighting and is controlled by an independent control device:~~
  - 2.1. ~~Task lighting for medical and dental purposes.~~
  - 2.2. ~~Display lighting for exhibits in galleries, museums and monuments.~~
3. ~~Lighting for theatrical purposes, including performance, stage, film production and video production.~~
4. ~~Lighting for photographic processes.~~
5. ~~Lighting integral to equipment or instrumentation and installed by the manufacturer.~~
6. ~~Task lighting for plant growth or maintenance.~~
  7. ~~Advertising signage or directional signage.~~
- Task lighting for plant growth or maintenance.
7. ~~Advertising signage or directional signage.~~
8. ~~In restaurant buildings and areas, lighting for food warming or integral to food preparation equipment.~~
9. ~~Lighting equipment that is for sale.~~
10. ~~Lighting demonstration equipment in lighting education facilities.~~
11. ~~Lighting *approved* because of safety or emergency considerations, inclusive of exit lights.~~
12. ~~Lighting integral to both open and glassenclosed refrigerator and freezer cases.~~
13. ~~Lighting in retail display windows, provided the display area is enclosed by ceiling height partitions.~~
14. ~~Furniture mounted supplemental task lighting that is controlled by automatic shutoff.~~

15. Exit signs.

The connected power associated with the following lighting equipment and applications is not included in calculating total connected lighting power.

1. Television broadcast lighting for playing areas in sports arenas.
2. Emergency lighting automatically off during normal building operation.
3. Lighting in spaces specifically designed for use by occupants with special lighting needs, including those with visual impairment and other medical and age-related issues.
4. Casino gaming areas.
5. Mirror lighting in dressing rooms.
6. Task lighting for medical and dental purposes that is in addition to general lighting.
7. Display lighting for exhibits in galleries, museums and monuments that is in addition to general lighting.
8. Lighting for theatrical purposes, including performance, stage, film production and video production.
9. Lighting for photographic processes.
10. Lighting integral to equipment or instrumentation and installed by the manufacturer.
11. Task lighting for plant growth or maintenance.
12. Advertising signage or directional signage.
13. Lighting for food warming.
14. Lighting equipment that is for sale.
15. Lighting demonstration equipment in lighting education facilities.
16. Lighting approved because of safety considerations.
17. Lighting in retail display windows, provided that the display area is enclosed by ceiling-height partitions.
18. Furniture-mounted supplemental task lighting that is controlled by automatic shutoff.
19. Exit signs.
20. Antimicrobial lighting used for the sole purpose of disinfecting a space.

**C405.4.2 Interior lighting power.** The total interior lighting power allowance (watts) is determined according to Table C405.4.2(1) using the Building Area Method, or Table C405.4.2(2) using the Space-by-Space Method, for all areas of the building covered in this permit.

**C405.4.2 C405.3.2 Interior lighting power allowance.** The total interior lighting power allowance (watts) for an entire building shall be determined according to Table C405.3.2(1) using the Building Area Method or Table C405.3.2(2) using the Space-by-Space Method. The interior lighting power allowance for projects that involve only portions of a building shall be determined according to Table C405.3.2(2) using the Space-by-Space Method. Buildings with unfinished spaces shall use the Space-by-Space Method.

**C405.4.2.1 Building Area Method.** For the Building Area Method, the interior lighting power allowance is the floor area for each building area type listed in Table C405.4.2(1) times the value from Table C405.4.2(1) for that area. For the purposes of this method, an “area” shall be defined as all contiguous spaces that accommodate or are associated with a single building area type, as listed in Table C405.4.2(1). Where this method is used to calculate the total interior lighting power for an entire building, each building area type shall be treated as a separate area. Trade-offs among building area types are permitted.

**C405.4.2.1 C405.3.2.1 Building Area Method.** For the Building Area Method, the interior lighting power allowance is calculated as follows:

1. For each building area type inside the building, determine the applicable building area type and the allowed lighting power density for that type from Table C405.3.2(1). For building area types not listed, select the building area type that most closely represents the use of that area. For the purposes of this method, an “area” shall be defined as all contiguous spaces that accommodate or are associated with a single building area type.

2. Determine the floor area for each building area type listed in Table C405.3.2(1) and multiply this area by the applicable value from Table C405.3.2(1) to determine the lighting power (watts) for each building area type.
3. The total interior lighting power allowance (watts) for the entire building is the sum of the lighting power from each building area type.

**C405.4.2.2 Space-by-Space Method.** For the Space-by-Space Method, the interior lighting power allowance is determined by multiplying the floor area of each space times the value for the space type in Table C405.4.2(2) that most closely represents the proposed use of the space, and then summing the lighting power allowances for all spaces. Trade-offs among spaces are permitted.

**C405.4.2.2 C405.3.2.2 Space-by-Space Method.** Where a building has unfinished spaces, the lighting power allowance for the unfinished spaces shall be the total connected lighting power for those spaces, or 0.2 watts per square foot (10.76 w/m<sup>2</sup>), whichever is less. For the Space-by-Space Method, the interior lighting power allowance is calculated as follows:

1. For each space enclosed by partitions that are not less than 80 percent of the ceiling height, determine the applicable space type from Table C405.3.2(2). For space types not listed, select the space type that most closely represents the proposed use of the space. Where a space has multiple functions, that space may be divided into separate spaces.
2. Determine the total floor area of all the spaces of each space type and multiply by the value for the space type in Table C405.3.2(2) to determine the lighting power (watts) for each space type.
3. The total interior lighting power allowance (watts) shall be the sum of the lighting power allowances for all space types.

**C405.3.2.2.1 Additional interior lighting power.** Where using the Space-by-Space Method, an increase in the interior lighting power allowance is permitted for specific lighting functions. Additional power shall be permitted only where the specified lighting is installed and controlled in accordance with Section C405.2.4. This additional power shall be used only for the specified luminaires and shall not be used for any other purpose. An increase in the interior lighting power allowance is permitted in the following cases:

1. For lighting equipment to be installed in sales areas specifically to highlight merchandise, the additional lighting power shall be determined in accordance with Equation 4-10-11.

$$\begin{aligned} \text{Additional interior lighting power allowance} = & \\ & 500 \text{ watts} + (\text{Retail Area 1} \cdot 0.6 \text{ W/ft}^2) + \\ & (\text{Retail Area 2} \cdot 0.6 \text{ W/ft}^2) + (\text{Retail Area 3} \cdot \\ & 1.4 \text{ W/ft}^2) + (\text{Retail Area 4} \cdot 2.5 \text{ W/ft}^2) \end{aligned}$$

**(Equation 4-10)**

$$\begin{aligned} \text{Additional interior lighting power allowance} = & \\ & 1000 \text{ W} + (\text{Retail Area 1} \times 0.45 \text{ W/ft}^2) + \\ & (\text{Retail Area 2} \times 0.45 \text{ W/ft}^2) + (\text{Retail Area 3} \times \\ & 1.05 \text{ W/ft}^2) + (\text{Retail Area 4} \times 1.87 \text{ W/ft}^2) \end{aligned}$$

For SI units:

$$\begin{aligned} \text{Additional interior lighting power allowance} = & \\ & 500 \text{ watts} + (\text{Retail Area 1} \cdot 0.6 \text{ W/ft}^2) + \\ & (\text{Retail Area 2} \cdot 0.6 \text{ W/ft}^2) + (\text{Retail Area 3} \cdot \\ & 1.4 \text{ W/ft}^2) + (\text{Retail Area 4} \cdot 2.5 \text{ W/ft}^2) \end{aligned}$$

**(Equation 4-10)**

$$\begin{aligned} \text{Additional interior lighting power allowance} = & \\ & 1000 \text{ W} + (\text{Retail Area 1} \times 4.8 \text{ W/m}^2) + \\ & (\text{Retail Area 2} \times 4.84 \text{ W/m}^2) + (\text{Retail Area 3} \\ & \times 11 \text{ W/m}^2) + (\text{Retail Area 4} \times 20 \text{ W/m}^2) \end{aligned}$$

**(Equation 4-11)**

where:

*Retail Area 1* = The floor area for all products not listed in Retail Area 2, 3 or 4.

*Retail Area 2* = The floor area used for the sale of vehicles, sporting goods and small electronics.

*Retail Area 3* = The floor area used for the sale of furniture, clothing, cosmetics and artwork.

*Retail Area 4* = The floor area used for the sale of jewelry, crystal and china.

**Exception:** Other merchandise categories are permitted to be included in Retail Areas 2 through 4, provided that justification documenting the need for additional lighting power based on visual inspection, contrast or other critical display is approved by the code official.

- For spaces in which lighting is specified to be installed in addition to the general lighting for the purpose of decorative appearance or for highlighting art or exhibits, provided that the additional lighting power shall be not more than ~~1.0 w/sq. ft.~~  $0.9 \text{ W/ft}^2$  ( $9.7 \text{ W/m}^2$ ) ~~of such spaces~~ in lobbies and not more than  $0.75 \text{ W/ft}^2$  ( $8.1 \text{ W/m}^2$ ) in other spaces.

**C405.4 Lighting for plant growth and maintenance.** Not less than 95 percent of the permanently installed luminaires used for plant growth and maintenance shall have a photon efficiency of not less than  $1.6 \mu\text{mol/J}$  as defined in accordance with ANSI/ASABE S640.

**TABLE C405.4.2(1)  
INTERIOR LIGHTING POWER ALLOWANCES:  
BUILDING AREA METHOD**

BUILDING AREA TYPE	LPD (w/ft <sup>2</sup> )
Automotive facility	0.80
Convention center	1.01
Courthouse	1.01
Dining: bar lounge/leisure	1.01
Dining: cafeteria/fast food	0.9
Dining: family	0.95
Dormitory	0.57
Exercise center	0.84
Fire station	0.67
Gymnasium	0.94
Health care clinic	0.90
Hospital	1.05
Hotel/Motel	0.87
Library	1.19
Manufacturing facility	1.17
Motion picture theater	0.75
Multifamily	0.81
Museum	1.02
Office	0.82
Parking garage	0.21
Penitentiary	0.31
Performing arts theater	1.29
Police station	0.37
Post office	0.37
Religious building	1.0
Retail	1.26
School/university	0.37
Sports arena	0.31
Town hall	0.39
Transportation	0.70
Warehouse	0.46
Workshop	1.10

**Table C405.4.2(1) TABLE C405.3.2(1)**  
**INTERIOR LIGHTING POWER ALLOWANCES:**  
**BUILDING AREA METHOD**

BUILDING AREA TYPE	LPD (watts/ft <sup>2</sup> )
Automotive facility	<u>0.75</u>
Convention center	<u>0.64</u>
Courthouse	<u>0.79</u>
Dining: bar lounge/leisure	<u>0.80</u>
Dining: cafeteria/fast food	<u>0.76</u>
Dining: family	<u>0.71</u>
Dormitory <sup>a, b</sup>	<u>0.53</u>
Exercise center	<u>0.72</u>
Fire station <sup>a</sup>	<u>0.56</u>
Gymnasium	<u>0.76</u>
Health care clinic	<u>0.81</u>
Hospital <sup>a</sup>	<u>0.96</u>
Hotel/Motel <sup>a, b</sup>	<u>0.56</u>
Library	<u>0.83</u>
Manufacturing facility	<u>0.82</u>
Motion picture theater	<u>0.44</u>
Multiple-family <sup>c</sup>	<u>0.45</u>
Museum	<u>0.55</u>
Office	<u>0.64</u>

**TABLE C405.4.2(1) TABLE C405.3.2(1)continued**  
**INTERIOR LIGHTING POWER ALLOWANCES:**  
**BUILDING AREA METHOD**

BUILDING AREA TYPE	LPD (watts/ft <sup>2</sup> )
Parking garage	<u>0.18</u>
Penitentiary	<u>0.69</u>
Performing arts theater	<u>0.84</u>
Police station	<u>0.66</u>
Post office	<u>0.65</u>
Religious building	<u>0.67</u>
Retail	<u>0.84</u>
School/university	<u>0.72</u>

Sports arena	<u>0.76</u>
Town hall	<u>0.69</u>
Transportation	<u>0.50</u>
Warehouse	<u>0.45</u>
Workshop	<u>0.91</u>

For SI: 1 watt per square foot = 10.76 w/m<sup>2</sup>.

- a. Where sleeping units are excluded from lighting power calculations by application of Section R404.1, neither the area of the sleeping units nor the wattage of lighting in the sleeping units is counted.
- b. Where dwelling units are excluded from lighting power calculations by application of Section R404.1, neither the area of the dwelling units nor the wattage of lighting in the dwelling units is counted.
- c. Dwelling units are excluded. Neither the area of the dwelling units nor the wattage of lighting in the dwelling units is counted.

**TABLE C405.4.2(2)  
INTERIOR LIGHTING POWER ALLOWANCES:  
SPACE-BY-SPACE METHOD**

COMMON SPACE TYPES <sup>a</sup>	LPD (watts/sq.ft)
Atrium	
Less than 40 feet in height	0.03 per foot in total height
Greater than 40 feet in height	0.40 + 0.02 per foot in total height
Audience seating area	
In an auditorium	0.63
In a convention center	0.82
In a gymnasium	0.65
In a motion picture theater	1.14
In a penitentiary	0.28
In a performing arts theater	2.43
In a religious building	1.53
In a sports arena	0.43
Otherwise	0.43
Banking activity area	1.01
Breakroom (See Lounge/Breakroom)	
Classroom/lecture hall/training room	

~~Table C405.4.2(2)~~ **TABLE C405.3.2(2)** [note to reviewer, replace Table C405.4.2(2) 2018 in its entirety with Table C405.3.2(2)]

**INTERIOR LIGHTING POWER ALLOWANCES:  
SPACE-BY-SPACE METHOD**

COMMON SPACE TYPES <sup>a</sup>	LPD (watts/ft <sup>2</sup> )
Atrium	
Less than 40 feet in height	<u>0.48</u>
Greater than 40 feet in height	<u>0.60</u>
<u>Audience seating area</u>	

In an auditorium	<u>0.61</u> □
In a gymnasium	<u>0.23</u>
In a motion picture theater	<u>0.27</u>
In a penitentiary	<u>0.67</u>
<u>In a performing arts theater</u>	<u>1.16</u>
In a religious building	<u>0.72</u>
In a sports arena	<u>0.33</u>
Otherwise	<u>0.33</u>
Banking activity area	<u>0.61</u>
Breakroom (See Lounge/breakroom)	
Classroom/lecture hall/training room	
In a penitentiary	<u>0.89</u>
Otherwise	<u>0.71</u>
Computer room, data center	<u>0.94</u>
Conference/meeting/multipurpose room	<u>0.97</u>
Copy/print room	<u>0.31</u>

(continued)

**TABLE C405.4.2(2) TABLE C405.3.2(2) - continued**  
**INTERIOR LIGHTING POWER ALLOWANCES:**  
**SPACE-BY-SPACE METHOD**

COMMON SPACE TYPES <sup>a</sup>	LPD (watts/ft <sup>2</sup> )
Corridor	
<u>In a facility for the visually impaired (and not used primarily by the staff)<sup>b</sup></u>	<u>0.71</u>
□ <u>In a hospital</u>	<u>0.71</u>
Otherwise	<u>0.41</u>
Courtroom	<u>1.20</u>
Dining area	
In bar/lounge or leisure dining	<u>0.86</u>
<u>In cafeteria or fast food dining</u>	<u>0.40</u>
<u>In a facility for the visually impaired (and not used primarily by the staff)<sup>b</sup></u>	<u>1.27</u>
<u>In family dining</u>	<u>0.60</u>
<u>In a penitentiary</u>	<u>0.42</u>
<u>Otherwise</u>	<u>0.43</u>

<u>Electrical/mechanical room</u>	<u>0.43</u>
<u>Emergency vehicle garage</u>	<u>0.52</u>
<u>Food preparation area</u>	<u>1.09</u>
<u>Guestroom<sup>c, d</sup></u>	<u>0.41</u>
Laboratory	
<u>In or as a classroom</u>	<u>1.11</u>
<u>Otherwise</u>	<u>1.33</u>
<u>Laundry/washing area</u>	<u>0.53</u>
<u>Loading dock, interior</u>	<u>0.88</u>
Lobby	
<u>For an elevator</u>	<u>0.65</u>
<u>In a facility for the visually impaired (and not used primarily by the staff)<sup>b</sup></u>	<u>1.69</u>
<u>In a hotel</u>	<u>0.51</u>
<u>In a motion picture theater</u>	<u>0.23</u>
<u>In a performing arts theater</u>	<u>1.25</u>
<u>Otherwise</u>	<u>0.84</u>
<u>Locker room</u>	<u>0.52</u>
Lounge/breakroom	
<u>In a healthcare facility</u>	<u>0.42</u>
<u>Otherwise</u>	<u>0.59</u>
Office	
<u>Enclosed</u>	<u>0.74</u>
<u>Open plan</u>	<u>0.61</u>
<u>Parking area, interior</u>	<u>0.15</u>
<u>Pharmacy area</u>	<u>1.66</u>
Restroom	
<u>In a facility for the visually impaired (and not used primarily by the staff)<sup>b</sup></u>	<u>1.26</u>
<u>Otherwise</u>	<u>0.63</u>
<u>Sales area</u>	<u>1.05</u>

(continued)

**TABLE C405.4.2(2) TABLE C405.3.2(2) - continued**

**INTERIOR LIGHTING POWER ALLOWANCES:  
SPACE-BY-SPACE METHOD**

COMMON SPACE TYPES <sup>a</sup>	LPD (watts/ft <sup>2</sup> )
---------------------------------	------------------------------



<u>Seating area, general</u>	<u>0.23</u>
<u>Stairwell</u>	<u>0.49</u>
<u>Storage room</u>	<u>0.38</u>
<u>Vehicular maintenance area</u>	<u>0.60</u>
<u>Workshop</u>	<u>1.26</u>
<u>BUILDING TYPE SPECIFIC SPACE TYPES<sup>a</sup></u>	<u>LPD (watts/ ft<sup>2</sup>)</u>
<u>Automotive (see Vehicular maintenance area)</u>	
<u>Convention Center—exhibit space</u>	<u>0.61</u>
<u>Dormitory—living quarters<sup>c, d</sup></u>	<u>0.50</u>
<u>Facility for the visually impaired<sup>b</sup></u>	
<u>In a chapel (and not used primarily by the staff)</u>	<u>0.70</u>
<u>In a recreation room (and not used primarily by the staff)</u>	<u>1.77</u>
<u>Fire Station—sleeping quarters<sup>c</sup></u>	<u>0.23</u>
<u>Gymnasium/fitness center</u>	
<u>In an exercise area</u>	<u>0.90</u>
<u>In a playing area</u>	<u>0.85</u>
<u>Healthcare facility</u>	
<u>In an exam/treatment room</u>	<u>1.40</u>
<u>In an imaging room</u>	<u>0.94</u>
<u>In a medical supply room</u>	<u>0.62</u>
<u>In a nursery</u>	<u>0.92</u>
<u>In a nurse’s station</u>	<u>1.17</u>
<u>In an operating room</u>	<u>2.26</u>
<u>In a patient room<sup>c</sup></u>	<u>0.68</u>
<u>In a physical therapy room</u>	<u>0.91</u>
<u>In a recovery room</u>	<u>1.25</u>
<u>Library</u>	
<u>In a reading area</u>	<u>0.96</u>
<u>In the stacks</u>	<u>1.18</u>
<u>Manufacturing facility</u>	
<u>In a detailed manufacturing area</u>	<u>0.80</u>
<u>In an equipment room</u>	<u>0.76</u>
<u>In an extra-high-bay area (greater than 50 feet floor-to-ceiling height)</u>	<u>1.42</u>

<u>In a high-bay area (25–50 feet floor-to-ceiling height)</u>	<u>1.24</u>
<u>In a low-bay area (less than 25 feet floor-to-ceiling height)</u>	<u>0.86</u>
<u>Museum</u>	
<u>In a general exhibition area</u>	<u>0.31</u>
<u>In a restoration room</u>	<u>1.10</u>
<u>Performing arts theater—dressing room</u>	<u>0.41</u>
<u>Post office—sorting area</u>	<u>0.76</u>

(continued)

**TABLE C405.4.2(2) TABLE C405.3.2(2) - continued**  
**INTERIOR LIGHTING POWER ALLOWANCES:**  
**SPACE-BY-SPACE METHOD**

<u>COMMON SPACE TYPES<sup>a</sup></u>	<u>LPD (watts/ft<sup>2</sup>)</u>
<u>Religious buildings</u>	
<u>In a fellowship hall</u>	<u>0.54</u>
<u>In a worship/pulpit/choir area</u>	<u>0.85</u>
<u>Retail facilities</u>	
<u>In a dressing/fitting room</u>	<u>0.51</u>
<u>In a mall concourse</u>	<u>0.82</u>
<u>Sports arena—playing area</u>	
<u>For a Class I facility<sup>e</sup></u>	<u>2.94</u>
<u>For a Class II facility<sup>f</sup></u>	<u>2.01</u>
<u>For a Class III facility<sup>g</sup></u>	<u>1.30</u>
<u>For a Class IV facility<sup>h</sup></u>	<u>0.86</u>
<u>Transportation facility</u>	
<u>At a terminal ticket counter</u>	<u>0.51</u>
<u>In a baggage/carousel area</u>	<u>0.39</u>
<u>In an airport concourse</u>	<u>0.25</u>
<u>Warehouse—storage area</u>	
<u>For medium to bulky, palletized items</u>	<u>0.33</u>
<u>For smaller, hand-carried items</u>	<u>0.69</u>

For SI: 1 foot = 304.8 mm, 1 watt per square foot = 10.76 w/m<sup>2</sup>.

- a. In cases where both a common space type and a building area specific space type are listed, the building area specific space type shall apply.
- b. A 'Facility for the Visually Impaired' is a facility that is licensed or will be licensed by local or state authorities for senior long-term care, adult daycare, senior support or people with special visual needs.

- c. Where sleeping units are excluded from lighting power calculations by application of Section R404.1, neither the area of the sleeping units nor the wattage of lighting in the sleeping units is counted.
- d. Where dwelling units are excluded from lighting power calculations by application of Section R404.1, neither the area of the dwelling units nor the wattage of lighting in the dwelling units is counted.
- e. Class I facilities consist of professional facilities; and semiprofessional, collegiate, or club facilities with seating for 5,000 or more spectators.
- f. Class II facilities consist of collegiate and semiprofessional facilities with seating for fewer than 5,000 spectators; club facilities with seating for between 2,000 and 5,000 spectators; and amateur league and high school facilities with seating for more than 2,000 spectators.
- g. Class III facilities consist of club, amateur league and high school facilities with seating for 2,000 or fewer spectators.
- h. Class IV facilities consist of elementary school and recreational facilities; and amateur league and high school facilities without provision for spectators.

**C405.5 Exterior lighting (Mandatory).** Where the power for exterior lighting is supplied through the energy service to the building, all exterior lighting shall comply with Section C405.5.1.

**C405.5 Exterior lighting power requirements.** The total connected exterior lighting power calculated in accordance with Section C405.5.1 shall be not greater than the exterior lighting power allowance calculated in accordance with Section C405.5.2.

**Exception:** Where *approved* because of historical, safety, signage or emergency considerations.

**C405.5.1 Exterior building lighting power.** The total exterior lighting power allowance for all exterior building applications is the sum of the base site allowance plus the individual allowances for areas that are to be illuminated and are permitted in Table C405.5.1(2) for the applicable lighting zone. Trade offs are allowed only among exterior lighting applications listed in Table C405.5.1(2), in the Tradable Surfaces section. The lighting zone for the building exterior is determined from Table C405.5.1(1) unless otherwise specified by the local jurisdiction.

**C405.5.1 Total connected exterior building exterior lighting power.** The total exterior connected lighting power shall be the total maximum rated wattage of all lighting that is powered through the energy service for the building.

**Exception:** Lighting used for the following exterior applications is exempt where equipped with a control device independent of the control of the nonexempt lighting:

1. Specialized signal, directional and marker lighting associated with transportation.
2. Advertising signage or directional signage.
3. Integral to equipment or instrumentation and is installed by its manufacturer.
4. Theatrical purposes, including performance, stage, film production and video production.
5. Athletic playing areas.
6. Temporary lighting.
7. Industrial production, material handling, transportation sites and associated storage areas.
8. Theme elements in theme/amusement parks.
9. Used to highlight features of public monuments and registered historic landmark structures or buildings.

**Exception:** Lighting used for the following applications shall not be included.

1. Lighting *approved* because of safety considerations.
2. Emergency lighting automatically off during normal business operation.
3. Exit signs.
4. Specialized signal, directional and marker lighting associated with transportation.

5. Advertising signage or directional signage.
6. Integral to equipment or instrumentation and installed by its manufacturer.
7. Theatrical purposes, including performance, stage, film production and video production.
8. Athletic playing areas.
9. Temporary lighting.
10. Industrial production, material handling, transportation sites and associated storage areas.
11. Theme elements in theme/amusement parks.
12. Used to highlight features of art, public monuments and the national flag.
13. Lighting for water features and swimming pools.
14. Lighting controlled from within dwelling units, where the lighting complies with Section R404.1.

**C405.5.2 Exterior lighting power allowance.** The exterior lighting power allowance (watts) is calculated as follows:

1. Determine the Lighting Zone (LZ) for the building according to Table C405.5.2(1), unless otherwise specified by the code official.
2. For each exterior area that is to be illuminated by lighting that is powered through the energy service for the building, determine the applicable area type from Table C405.5.2(2). For area types not listed, select the area type that most closely represents the proposed use of the area.
3. Determine the total area or length of each area type and multiply by the value for the area type in Table C405.5.2(2) to determine the lighting power (watts) allowed for each area type.
4. The total exterior lighting power allowance (watts) is the sum of the base site allowance determined according to Table C405.5.2(2), plus the watts from each area type.

**TABLE C405.5.1(4) C405.5.2(1)**  
**EXTERIOR LIGHTING ZONES**

LIGHTING ZONE	DESCRIPTION
1	Developed areas of national parks, state parks, forest land, and rural areas
2	Areas predominantly consisting of residential zoning, neighborhood business districts, light industrial with limited nighttime use and residential mixed-use areas
3	All other areas not classified as lighting zone 1, 2 or 4
4	High-activity commercial districts in major metropolitan areas as designated by the local land use planning authority

**C405.5.2.1 Additional exterior lighting power.** Additional exterior lighting power allowances are available for the specific lighting applications listed in Table C405.5.2(3). These additional power allowances shall be used only for the luminaires serving these specific applications and shall not be used to increase any other lighting power allowance.

**TABLE C405.5.1(2)  
INDIVIDUAL LIGHTING POWER ALLOWANCES FOR BUILDING EXTERIORS**

	LIGHTING ZONES			
	Zone 1	Zone 2	Zone 3	Zone 4
Base Site Allowance (Base allowance is usable in tradable or nontradable surfaces.)	500 W	600 W	750 W	1300 W
<b>Uncovered Parking Areas</b>				
Parking areas and drives	0.04 W/ft <sup>2</sup>	0.06 W/ft <sup>2</sup>	0.10 W/ft <sup>2</sup>	0.13 W/ft <sup>2</sup>
<b>Building Grounds</b>				
Walkways less than 10 feet wide	0.7 W/linear foot	0.7 W/linear foot	0.8 W/linear foot	1.0 W/linear foot
Walkways 10 feet wide or greater, plaza areas, special feature areas	0.14 W/ft <sup>2</sup>	0.14 W/ft <sup>2</sup>	0.16 W/ft <sup>2</sup>	0.2 W/ft <sup>2</sup>
Stairways	0.75 W/ft <sup>2</sup>	1.0 W/ft <sup>2</sup>	1.0 W/ft <sup>2</sup>	1.0 W/ft <sup>2</sup>
Pedestrian tunnels	0.15 W/ft <sup>2</sup>	0.15 W/ft <sup>2</sup>	0.2 W/ft <sup>2</sup>	0.3 W/ft <sup>2</sup>
<b>Building Entrances and Exits</b>				
Main entries	20 W/linear foot of door width	20 W/linear foot of door width	30 W/linear foot of door width	30 W/linear foot of door width
Other entries	20 W/linear foot	20 W/linear foot	20 W/linear foot	20 W/linear foot

**TABLE C405.5.1(2) TABLE C405.5.2(2)  
LIGHTING POWER ALLOWANCES FOR BUILDING EXTERIORS**

	LIGHTING ZONES			
	Zone 1	Zone 2	Zone 3	Zone 4
<u>Base Site Allowance</u>	<u>350 W</u>	<u>400 W</u>	<u>500 W</u>	<u>900 W</u>
<b>Uncovered Parking Areas</b>				
<u>Parking areas and drives</u>	<u>0.03 W/ft<sup>2</sup></u>	<u>0.04 W/ft<sup>2</sup></u>	<u>0.06 W/ft<sup>2</sup></u>	<u>0.08 W/ft<sup>2</sup></u>
<b>Building Grounds</b>				
<u>Walkways and ramps less than 10 feet wide</u>	<u>0.50 W/linear foot</u>	<u>0.50 W/linear foot</u>	<u>0.60 W/linear foot</u>	<u>0.70 W/linear foot</u>
<u>Walkways and ramps 10 feet wide or greater, plaza areas, special feature areas</u>	<u>0.10 W/ft<sup>2</sup></u>	<u>0.10 W/ft<sup>2</sup></u>	<u>0.11 W/ft<sup>2</sup></u>	<u>0.14 W/ft<sup>2</sup></u>
<u>Dining areas</u>	<u>0.65 W/ft<sup>2</sup></u>	<u>0.65 W/ft<sup>2</sup></u>	<u>0.75 W/ft<sup>2</sup></u>	<u>0.95 W/ft<sup>2</sup></u>
<u>Stairways</u>	<u>0.60 W/ft<sup>2</sup></u>	<u>0.70 W/ft<sup>2</sup></u>	<u>0.70 W/ft<sup>2</sup></u>	<u>0.70 W/ft<sup>2</sup></u>
<u>Pedestrian tunnels</u>	<u>0.12 W/ft<sup>2</sup></u>	<u>0.12 W/ft<sup>2</sup></u>	<u>0.14 W/ft<sup>2</sup></u>	<u>0.21 W/ft<sup>2</sup></u>
<u>Landscaping</u>	<u>0.03 W/ft<sup>2</sup></u>	<u>0.04 W/ft<sup>2</sup></u>	<u>0.04 W/ft<sup>2</sup></u>	<u>0.04 W/ft<sup>2</sup></u>
<b>Building Entrances and Exits</b>				
<u>Pedestrian and vehicular entrances and exits</u>	<u>14 W/linear foot of opening</u>	<u>14 W/linear foot of opening</u>	<u>21 W/linear foot of opening</u>	<u>21 W/linear foot of opening</u>
<u>Entry canopies</u>	<u>0.20 W/ft<sup>2</sup></u>	<u>0.25 W/ft<sup>2</sup></u>	<u>0.40 W/ft<sup>2</sup></u>	<u>0.40 W/ft<sup>2</sup></u>
<u>Loading docks</u>	<u>0.35 W/ft<sup>2</sup></u>	<u>0.35 W/ft<sup>2</sup></u>	<u>0.35 W/ft<sup>2</sup></u>	<u>0.35 W/ft<sup>2</sup></u>
<b>Sales Canopies</b>				

<u>Free-standing and attached</u>	<u>0.40 W/ft<sup>2</sup></u>	<u>0.40 W/ft<sup>2</sup></u>	<u>0.60 W/ft<sup>2</sup></u>	<u>0.70 W/ft<sup>2</sup></u>
<u>Outdoor Sales</u>				
<u>Open areas (including vehicle sales lots)</u>	<u>0.20 W/ft<sup>2</sup></u>	<u>0.20 W/ft<sup>2</sup></u>	<u>0.35 W/ft<sup>2</sup></u>	<u>0.50 W/ft<sup>2</sup></u>
<u>Street frontage for vehicle sales lots in addition to "open area" allowance</u>	<u>No allowance</u>	<u>7 W/linear foot</u>	<u>7 W/linear foot</u>	<u>21 W/linear foot</u>

For SI: 1 foot = 304.8 mm, 1 watt per square foot = W/0.0929 m<sup>2</sup>.  
W = watts.

~~Table C405.5.1(2)~~ **TABLE C405.5.2(3)**  
**INDIVIDUAL LIGHTING POWER ALLOWANCES FOR BUILDING EXTERIORS**

LIGHTING ZONES				
	Zone 1	Zone 2	Zone 3	Zone 4
Building facades	<u>No allowance</u>	<u>0.075 W/ft<sup>2</sup> of gross above-grade wall area</u>	<u>0.113 W/ft<sup>2</sup> of gross above-grade wall area</u>	<u>0.15 W/ft<sup>2</sup> of gross above-grade wall area</u>
Automated teller machines (ATM) and night depositories	<u>135 W per location plus 45 W per additional ATM per location</u>			
Uncovered entrances and gate-house inspection stations at guarded facilities	<u>0.50 W/ft<sup>2</sup> of area</u>			
Uncovered loading areas for law enforcement, fire, ambulance and other emergency service vehicles	<u>0.35 W/ft<sup>2</sup> of area</u>			
Drive-up windows and doors	<u>200 W per drive through</u>			
Parking near 24-hour retail entrances.	<u>400 W per main entry</u>			

For SI: For SI: 1 watt per square foot = W/0.0929 m<sup>2</sup>.  
W = watts.

**C405.5.3 Gas lighting.** Gas-fired lighting appliances shall not be equipped with continuously burning pilot ignition systems.

**C405.6 ~~Electrical energy consumption (Mandatory)~~ Dwelling electrical meter.** Each dwelling unit located in a *Group R-2* building shall have a separate electrical meter.

**C405.7 Electrical transformers (Mandatory).** ~~Electric~~ Low-voltage dry-type distribution electric transformers shall meet the minimum efficiency requirements of Table C405.7 as tested and rated in accordance with the test procedure listed in DOE 10 CFR 431. The efficiency shall be verified through certification under an approved certification program or, where a certification program does not exist, the equipment efficiency ratings shall be supported by data furnished by the transformer manufacturer.

**Exceptions:** The following transformers are exempt:

1. Transformers that meet the *Energy Policy Act of 2005* exclusions based on the DOE 10 CFR 431 definition of special purpose applications.
2. Transformers that meet the *Energy Policy Act of 2005* exclusions that are not to be used in general purpose applications based on information provided in DOE 10 CFR 431.
3. Transformers that meet the *Energy Policy Act of 2005* exclusions with multiple voltage taps where the highest tap is not less than 20 percent more than the lowest tap.

4. Drive transformers.
5. Rectifier transformers.
6. Auto-transformers.
7. Uninterruptible power system transformers.
8. Impedance transformers.
9. Regulating transformers.
10. Sealed and nonventilating transformers.
11. Machine tool transformers.
12. Welding transformers.
13. Grounding transformers.
14. Testing transformers.

**TABLE C405.7**

**MINIMUM NOMINAL EFFICIENCY LEVELS FOR DOE 10 CFR 431 LOW-VOLTAGE DRY-TYPE DISTRIBUTION TRANSFORMERS**

SINGLE-PHASE TRANSFORMERS		THREE-PHASE TRANSFORMERS	
kVA <sup>a</sup>	Efficiency (%) <sup>b</sup>	kVA <sup>a</sup>	Efficiency (%) <sup>b</sup>
15	97.70	15	<del>97.0</del> <u>97.89</u>
25	98.00	30	<del>97.5</del> <u>98.23</u>
37.5	98.20	45	<del>97.7</del> <u>98.40</u>
50	98.30	75	<del>98.0</del> <u>98.60</u>
75	98.50	112.5	<del>98.2</del> <u>98.74</u>
100	98.60	150	<del>98.3</del> <u>98.83</u>
167	98.70	225	<del>98.5</del> <u>98.94</u>
250	98.80	300	<del>98.6</del> <u>99.02</u>
333	98.90	500	<del>98.7</del> <u>99.14</u>
—	—	750	<del>98.8</del> <u>99.23</u>
—	—	1000	<del>98.9</del> <u>99.28</u>

a. kilovoltAmp rating.

b. Nominal efficiencies shall be established in accordance with the DOE 10 CFR 431 test procedure for low-voltage dry-type transformers.

**C405.8 Electric motors (Mandatory).** Electric motors shall meet the minimum efficiency requirements of Tables C405.8(1) through C405.8(4) when tested and rated in accordance with the DOE 10 CFR 431. The efficiency shall be verified through certification under an approved certification program or, where a certification program does not exist, the equipment efficiency ratings shall be supported by data furnished by the motor manufacturer.

**Exception:** The standards in this section shall not apply to the following exempt electric motors:

1. Air-over electric motors.
2. Component sets of an electric motor.
3. Liquid-cooled electric motors.
4. Submersible electric motors.
5. Inverter-only electric motors.

**TABLE C405.8(1)**  
**MINIMUM NOMINAL FULL-LOAD EFFICIENCY FOR 60 HZ NEMA**  
**GENERAL PURPOSE ELECTRIC MOTORS (SUBTYPE I) RATED 600 VOLTS OR LESS (Random Wound)<sup>a</sup>**

MOTOR HORSEPOWER	NUMBER OF POLES	OPEN DRIP-PROOF MOTORS			TOTALLY ENCLOSED FAN-COOLED MOTORS		
		2	4	6	2	4	6
	Synchronous Speed (RPM)	3600	1800	1200	3600	1800	1200
1		77.0	85.5	82.5	77.0	85.5	82.5
1.5		84.0	86.5	86.5	84.0	86.5	87.5
2		85.5	86.5	87.5	85.5	86.5	88.5
3		85.5	89.5	88.5	86.5	89.5	89.5
5		86.5	89.5	89.5	88.5	89.5	89.5
7.5		88.5	91.0	90.2	89.5	91.7	91.0
10		89.5	91.7	91.7	90.2	91.7	91.0
15		90.2	93.0	91.7	91.0	92.4	91.7
20		91.0	93.0	92.4	91.0	93.0	91.7
25		91.7	93.6	93.0	91.7	93.6	93.0
30		91.7	94.1	93.6	91.7	93.6	93.0
40		92.4	94.1	94.1	92.4	94.1	94.1
50		93.0	94.5	94.1	93.0	94.5	94.1
60		93.6	95.0	94.5	93.6	95.0	94.5
75		93.6	95.0	94.5	93.6	95.4	94.5
100		93.6	95.4	95.0	94.1	95.4	95.0
125		94.1	95.4	95.0	95.0	95.4	95.0
150		94.1	95.8	95.4	95.0	95.8	95.8
200		95.0	95.8	95.4	95.4	96.2	95.8
250		95.0	95.8	95.4	95.8	96.2	95.8
300		95.4	95.8	95.4	95.8	96.2	95.8
350		95.4	95.8	95.4	95.8	96.2	95.8
400		95.8	95.8	95.8	95.8	96.2	95.8
450		95.8	96.2	96.2	95.8	96.2	95.8
500		95.8	96.2	96.2	95.8	96.2	95.8

a. Nominal efficiencies shall be established in accordance with DOE 10 CFR 431.

**TABLE C405.8(1)**  
**MINIMUM NOMINAL FULL-LOAD EFFICIENCY FOR NEMA DESIGN A, NEMA DESIGN B,**  
**AND IEC DESIGN N MOTORS (EXCLUDING FIRE PUMP) ELECTRIC MOTORS AT 60 HZ<sup>a, b</sup>**

MOTOR HORSEPOWER (STANDARD KILOWATT EQUIVALENT)	NOMINAL FULL-LOAD EFFICIENCY (%) AS OF JUNE 1, 2016							
	2 Pole		4 Pole		6 Pole		8 Pole	
	Enclosed	Open	Enclosed	Open	Enclosed	Open	Enclosed	Open
<u>1 (0.75)</u>	<u>77.0</u>	<u>77.0</u>	<u>85.5</u>	<u>85.5</u>	<u>82.5</u>	<u>82.5</u>	<u>75.5</u>	<u>75.5</u>
<u>1.5 (1.1)</u>	<u>84.0</u>	<u>84.0</u>	<u>86.5</u>	<u>86.5</u>	<u>87.5</u>	<u>86.5</u>	<u>78.5</u>	<u>77.0</u>
<u>2 (1.5)</u>	<u>85.5</u>	<u>85.5</u>	<u>86.5</u>	<u>86.5</u>	<u>88.5</u>	<u>87.5</u>	<u>84.0</u>	<u>86.5</u>
<u>3 (2.2)</u>	<u>86.5</u>	<u>85.5</u>	<u>89.5</u>	<u>89.5</u>	<u>89.5</u>	<u>88.5</u>	<u>85.5</u>	<u>87.5</u>
<u>5 (3.7)</u>	<u>88.5</u>	<u>86.5</u>	<u>89.5</u>	<u>89.5</u>	<u>89.5</u>	<u>89.5</u>	<u>86.5</u>	<u>88.5</u>
<u>7.5 (5.5)</u>	<u>89.5</u>	<u>88.5</u>	<u>91.7</u>	<u>91.0</u>	<u>91.0</u>	<u>90.2</u>	<u>86.5</u>	<u>89.5</u>
<u>10 (7.5)</u>	<u>90.2</u>	<u>89.5</u>	<u>91.7</u>	<u>91.7</u>	<u>91.0</u>	<u>91.7</u>	<u>89.5</u>	<u>90.2</u>



<u>15 (11)</u>	<u>91.0</u>	<u>90.2</u>	<u>92.4</u>	<u>93.0</u>	<u>91.7</u>	<u>91.7</u>	<u>89.5</u>	<u>90.2</u>
<u>20 (15)</u>	<u>91.0</u>	<u>91.0</u>	<u>93.0</u>	<u>93.0</u>	<u>91.7</u>	<u>92.4</u>	<u>90.2</u>	<u>91.0</u>
<u>25 (18.5)</u>	<u>91.7</u>	<u>91.7</u>	<u>93.6</u>	<u>93.6</u>	<u>93.0</u>	<u>93.0</u>	<u>90.2</u>	<u>91.0</u>
<u>30 (22)</u>	<u>91.7</u>	<u>91.7</u>	<u>93.6</u>	<u>94.1</u>	<u>93.0</u>	<u>93.6</u>	<u>91.7</u>	<u>91.7</u>
<u>40 (30)</u>	<u>92.4</u>	<u>92.4</u>	<u>94.1</u>	<u>94.1</u>	<u>94.1</u>	<u>94.1</u>	<u>91.7</u>	<u>91.7</u>
<u>50 (37)</u>	<u>93.0</u>	<u>93.0</u>	<u>94.5</u>	<u>94.5</u>	<u>94.1</u>	<u>94.1</u>	<u>92.4</u>	<u>92.4</u>
<u>60 (45)</u>	<u>93.6</u>	<u>93.6</u>	<u>95.0</u>	<u>95.0</u>	<u>94.5</u>	<u>94.5</u>	<u>92.4</u>	<u>93.0</u>
<u>75 (55)</u>	<u>93.6</u>	<u>93.6</u>	<u>95.4</u>	<u>95.0</u>	<u>94.5</u>	<u>94.5</u>	<u>93.6</u>	<u>94.1</u>
<u>100 (75)</u>	<u>94.1</u>	<u>93.6</u>	<u>95.4</u>	<u>95.4</u>	<u>95.0</u>	<u>95.0</u>	<u>93.6</u>	<u>94.1</u>
<u>125 (90)</u>	<u>95.0</u>	<u>94.1</u>	<u>95.4</u>	<u>95.4</u>	<u>95.0</u>	<u>95.0</u>	<u>94.1</u>	<u>94.1</u>
<u>150 (110)</u>	<u>95.0</u>	<u>94.1</u>	<u>95.8</u>	<u>95.8</u>	<u>95.8</u>	<u>95.4</u>	<u>94.1</u>	<u>94.1</u>
<u>200 (150)</u>	<u>95.4</u>	<u>95.0</u>	<u>96.2</u>	<u>95.8</u>	<u>95.8</u>	<u>95.4</u>	<u>94.5</u>	<u>94.1</u>
<u>250 (186)</u>	<u>95.8</u>	<u>95.0</u>	<u>96.2</u>	<u>95.8</u>	<u>95.8</u>	<u>95.8</u>	<u>95.0</u>	<u>95.0</u>
<u>300 (224)</u>	<u>95.8</u>	<u>95.4</u>	<u>96.2</u>	<u>95.8</u>	<u>95.8</u>	<u>95.8</u>	=	=
<u>350 (261)</u>	<u>95.8</u>	<u>95.4</u>	<u>96.2</u>	<u>95.8</u>	<u>95.8</u>	<u>95.8</u>	=	=
<u>400 (298)</u>	<u>95.8</u>	<u>95.8</u>	<u>96.2</u>	<u>95.8</u>	=	=	=	=
<u>450 (336)</u>	<u>95.8</u>	<u>96.2</u>	<u>96.2</u>	<u>96.2</u>	=	=	=	=
<u>500 (373)</u>	<u>95.8</u>	<u>96.2</u>	<u>96.2</u>	<u>96.2</u>	=	=	=	=

a. Nominal efficiencies shall be established in accordance with DOE 10 CFR 431.

b. For purposes of determining the required minimum nominal full-load efficiency of an electric motor that has a horsepower or kilowatt rating between two horsepower or two kilowatt ratings listed in this table, each such motor shall be deemed to have a listed horsepower or kilowatt rating, determined as follows:

1. A horsepower at or above the midpoint between the two consecutive horsepowers shall be rounded up to the higher of the two horsepowers.
2. A horsepower below the midpoint between the two consecutive horsepowers shall be rounded down to the lower of the two horsepowers.
3. A kilowatt rating shall be directly converted from kilowatts to horsepower using the formula: 1 kilowatt = (1/0.746) horsepower. The conversion should be calculated to three significant decimal places, and the resulting horsepower shall be rounded in accordance with No. 1 or No. 2 above, as applicable.

**TABLE C405.8(2)**  
**MINIMUM NOMINAL FULL-LOAD EFFICIENCY OF**  
**GENERAL PURPOSE ELECTRIC MOTORS (SUBTYPE II) AND ALL DESIGN B MOTORS GREATER THAN 200 HORSEPOWER<sup>a</sup>**

MOTOR HORSEPOWER	NUMBER OF POLES	OPEN DRIP-PROOF MOTORS				TOTALLY ENCLOSED FAN-COOLED MOTORS			
		2	4	6	8	2	4	6	8
	Synchronous Speed (RPM)	3600	1800	1200	900	3600	1800	1200	900
1		NR	82.5	80.0	74.0	75.5	82.5	80.0	74.0
1.5		82.5	84.0	84.0	75.5	82.5	84.0	85.5	77.0
2		84.0	84.0	85.5	85.5	84.0	84.0	86.5	82.5
3		84.0	86.5	86.5	86.5	85.5	87.5	87.5	84.0
5		85.5	87.5	87.5	87.5	87.5	87.5	87.5	84.0
7.5		87.5	88.5	88.5	88.5	88.5	89.5	89.5	85.5
10		88.5	89.5	90.2	89.5	89.5	89.5	89.5	88.5
15		89.5	91.0	90.2	89.5	90.2	91.0	90.2	88.5
20		90.2	91.0	91.0	90.2	90.2	91.0	90.2	89.5
25		91.0	91.7	91.7	90.2	91.0	92.4	91.7	89.5
30		91.0	92.4	92.4	91.0	91.0	92.4	91.7	91.0
40		91.7	93.0	93.0	91.0	91.7	93.0	93.0	91.0
50		92.4	93.0	93.0	91.7	92.4	93.0	93.0	91.7
60		93.0	93.6	93.6	92.4	93.0	93.6	93.6	91.7
75		93.0	94.1	93.6	93.6	93.0	94.1	93.6	93.0
100		93.0	94.1	94.1	93.6	93.6	94.5	94.1	93.0
125		93.6	94.5	94.1	93.6	94.5	94.5	94.1	93.6
150		93.6	95.0	94.5	93.6	94.5	95.0	95.0	93.6
200		94.5	95.0	94.5	93.6	95.0	95.0	95.0	94.1
250		94.5	95.4	95.4	94.5	95.4	95.0	95.0	94.5
300		95.0	95.4	95.4	NR	95.4	95.4	95.0	NR
350		95.0	95.4	95.4	NR	95.4	95.4	95.0	NR
400		95.4	95.4	NR	NR	95.4	95.4	NR	NR
450		95.8	95.8	NR	NR	95.4	95.4	NR	NR
500		95.8	95.8	NR	NR	95.4	95.8	NR	NR

NR = No requirement.

a. Nominal efficiencies shall be established in accordance with DOE 10 CFR 431.

**TABLE C405.8(2) [note to reviewer - Replaces Table C405.8(2) in 2018 Code]**  
**MINIMUM NOMINAL FULL-LOAD EFFICIENCY FOR NEMA DESIGN C AND IEC DESIGN H MOTORS AT 60 HZ<sup>a, b</sup>**

MOTOR HORSEPOWER (STANDARD KILOWATT EQUIVALENT)	NOMINAL FULL-LOAD EFFICIENCY (%) AS OF JUNE 1, 2016					
	4 Pole		6 Pole		8 Pole	
	Enclosed	Open	Enclosed	Open	Enclosed	Open
1 (0.75)	85.5	85.5	82.5	82.5	75.5	75.5
1.5 (1.1)	86.5	86.5	87.5	86.5	78.5	77.0
2 (1.5)	86.5	86.5	88.5	87.5	84.0	86.5
3 (2.2)	89.5	89.5	89.5	88.5	85.5	87.5

5 (3.7)	89.5	89.5	89.5	89.5	86.5	88.5
7.5 (5.5)	91.7	91.0	91.0	90.2	86.5	89.5
10 (7.5)	91.7	91.7	91.0	91.7	89.5	90.2
15 (11)	92.4	93.0	91.7	91.7	89.5	90.2
20 (15)	93.0	93.0	91.7	92.4	90.2	91.0
25 (18.5)	93.6	93.6	93.0	93.0	90.2	91.0
30 (22)	93.6	94.1	93.0	93.6	91.7	91.7
40 (30)	94.1	94.1	94.1	94.1	91.7	91.7
50 (37)	94.5	94.5	94.1	94.1	92.4	92.4
60 (45)	95.0	95.0	94.5	94.5	92.4	93.0
75 (55)	95.4	95.0	94.5	94.5	93.6	94.1
100 (75)	95.4	95.4	95.0	95.0	93.6	94.1
125 (90)	95.4	95.4	95.0	95.0	94.1	94.1
150 (110)	95.8	95.8	95.8	95.4	94.1	94.1
200 (150)	96.2	95.8	95.8	95.4	94.5	94.1

- a. Nominal efficiencies shall be established in accordance with DOE 10 CFR 431.
- b. For purposes of determining the required minimum nominal full-load efficiency of an electric motor that has a horsepower or kilowatt rating between two horsepower or two kilowatt ratings listed in this table, each such motor shall be deemed to have a listed horsepower or kilowatt rating, determined as follows:
1. A horsepower at or above the midpoint between the two consecutive horsepowers shall be rounded up to the higher of the two horsepowers.
  2. A horsepower below the midpoint between the two consecutive horsepowers shall be rounded down to the lower of the two horsepowers.
  3. A kilowatt rating shall be directly converted from kilowatts to horsepower using the formula: 1 kilowatt = (1/0.746) horsepower. The conversion should be calculated to three significant decimal places, and the resulting horsepower shall be rounded in accordance with No. 1 or No. 2 above, as applicable.

**TABLE C405.8(3)**  
**MINIMUM AVERAGE FULL-LOAD EFFICIENCY POLYPHASE SMALL ELECTRIC MOTORS<sup>a</sup>**

MOTOR HORSEPOWER	OPEN MOTORS			
	Number of Poles	2	4	6
	Synchronous Speed (RPM)	3600	1800	1200
0.25	—	65.6	69.5	67.5
0.33	—	69.5	73.4	71.4
0.50	—	73.4	78.2	75.3
0.75	—	76.8	81.1	81.7
1	—	77.0	83.5	82.5
1.5	—	84.0	86.5	83.8
2	—	85.5	86.5	N/A
3	—	85.5	86.9	N/A

N/A = Not Applicable.

- a. Average full-load efficiencies shall be established in accordance with DOE 10 CFR 431.

**TABLE C405.8(4)**  
**MINIMUM AVERAGE FULL-LOAD EFFICIENCY FOR CAPACITOR-START CAPACITOR-RUN AND**  
**CAPACITOR-START INDUCTION-RUN SMALL ELECTRIC MOTORS<sup>a</sup>**

MOTOR HORSEPOWER	OPEN MOTORS			
	Number of Poles	2	4	6
	Synchronous Speed (RPM)	3600	1800	1200
0.25	—	66.6	68.5	62.2
0.33	—	70.5	72.4	66.6
0.50	—	72.4	76.2	76.2
0.75	—	76.2	81.8	80.2
1	—	80.4	82.6	81.1
1.5	—	81.5	83.8	N/A
2	—	82.9	84.5	N/A
3	—	84.1	N/A	N/A

**C405.9 Vertical and horizontal transportation systems and equipment.** Vertical and horizontal transportation systems and equipment shall comply with this section.

**C405.9.1 Elevator cabs. Elevator cabs.** For the luminaires in each elevator cab, not including signals and displays, the sum of the lumens divided by the sum of the watts shall be not less than 35 lumens per watt. Ventilation fans in elevators that do not have their own air-conditioning system shall not consume more than 0.33 watts/cfm at the maximum rated speed of the fan. Controls shall be provided that will de-energize ventilation fans and lighting systems when the elevator is stopped, unoccupied and with its doors closed for over 15 minutes.

**C405.9.2 Escalators and moving walks.** Escalators and moving walks shall comply with ASME A17.1/CSA B44 and shall have automatic controls that reduce speed as permitted in accordance with ASME A17.1/CSA B44 and applicable local code. ~~When not conveying passengers.~~

**Exception:** A variable voltage drive system that reduces operating voltage in response to light loading conditions is an alternative to the reduced speed function.

~~**C405.9.2.1 Regenerative drive.** An escalator designed either for one-way down operation only or for reversible operation shall have a variable frequency regenerative drive that supplies electrical energy to the building electrical system when the escalator is loaded with passengers whose combined weight exceeds 750 pounds (340 kg).~~

**C405.9.2.1 Energy recovery.** Escalators shall be designed to recover electrical energy when resisting overspeed in the down direction. The escalator shall be designed to recover, on average, more power than is consumed by the power recovery feature of its motor controller system.

**C405.10 Voltage drop.** The total *voltage drop* across the combination of customer-owned service conductors, feeder conductors and branch circuit conductors shall not exceed 5 percent.

**C405.11 Automatic receptacle control.** The following shall have automatic receptacle control complying with Section C405.11.1:

1. At least 50 percent of all 125V, 15- and 20-amp receptacles installed in enclosed offices, conference rooms, rooms used primarily for copy or print functions, breakrooms, classrooms and individual workstations, including those installed in modular partitions and module office workstation systems.
2. At least 25 percent of branch circuit feeders installed for modular furniture not shown on the construction documents.

**C405.11.1 Automatic receptacle control function.** Automatic receptacle controls shall comply with the following:

1. Either split controlled receptacles shall be provided with the top receptacle controlled, or a controlled receptacle shall be located within 12 inches (304.8 mm) of each uncontrolled receptacle.
2. One of the following methods shall be used to provide control:
  - 2.1. A scheduled basis using a time-of-day operated control device that turns receptacle power off at specific programmed times and can be programmed separately for each day of the week. The control device shall be configured to provide an independent schedule for each portion of the building of not more than 5,000 square feet (464.5 m<sup>2</sup>) and not more than one floor. The occupant shall be able to manually override an area for not more than 2 hours. Any individual override switch shall control the receptacles of not more than 5,000 feet (1524 m).
  - 2.2. An occupant sensor control that shall turn off receptacles within 20 minutes of all occupants leaving a space.
  - 2.3. An automated signal from another control or alarm system that shall turn off receptacles within 20 minutes after determining that the area is unoccupied.
3. All controlled receptacles shall be permanently marked in accordance with NFPA 70 and be uniformly distributed throughout the space.
4. Plug-in devices shall not comply.

**Exceptions:** Automatic receptacle controls are not required for the following:

1. Receptacles specifically designated for equipment requiring continuous operation (24 hours per day, 365 days per year).
2. Spaces where an automatic control would endanger the safety or security of the room or building occupants.
3. Within a single modular office workstation, noncontrolled receptacles are permitted to be located more than 12 inches (304.8 mm), but not more than 72 inches (1828 mm) from the controlled receptacles serving that workstation.

**C405.12 Energy monitoring.** New buildings with a gross conditioned floor area of 20,000 square feet (2322 m<sup>2</sup>) or larger shall be equipped to measure, monitor, record and report energy consumption data in compliance with Sections C405.12.1 through C405.12.5.

**Exception:** R-2 occupancies and individual tenant spaces are not required to comply with this section provided that the space has its own utility services and meters and has less than 5,000 square feet (464.5 m<sup>2</sup>) of conditioned floor area.

**C405.12.1 Electrical energy metering.** For all electrical energy supplied to the building and its associated site, including but not limited to site lighting, parking, recreational facilities and other areas that serve the building and its occupants, meters or other measurement devices shall be provided to collect energy consumption data for each end-use category required by Section C405.12.2.

**C405.12.2 End-use metering categories.** Meters or other approved measurement devices shall be provided to collect energy use data for each end-use category indicated in Table C405.12.2. Where multiple meters are used to measure any end-use category, the data acquisition system shall total all of the energy used by that category. Not more than 5 percent of the measured load for each of the end-use categories indicated in Table C405.12.2 shall be permitted to be from a load that is not within that category.

**Exceptions:**

1. HVAC and water heating equipment serving only an individual dwelling unit shall not require end-use metering.
2. End-use metering shall not be required for fire pumps, stairwell pressurization fans or any system that operates only during testing or emergency.
3. End-use metering shall not be required for an individual tenant space having a floor area not greater than 2,500 square feet (232 m<sup>2</sup>) where a dedicated source meter complying with Section C405.12.3 is provided.

**TABLE C405.12.2**  
**ENERGY USE CATEGORIES**

LOAD CATEGORY	DESCRIPTION OF ENERGY USE
<u>Total HVAC system</u>	<u>Heating, cooling and ventilation, including but not limited to fans, pumps, boilers, chillers and water heating. Energy used by 120-volt equipment, or by 208/120-volt equipment that is located in a building where the main service is 480/277-volt power, is permitted to be excluded from total HVAC system energy use.</u>
<u>Interior lighting</u>	<u>Lighting systems located within the building.</u>
<u>Exterior lighting</u>	<u>Lighting systems located on the building site but not within the building.</u>
<u>Plug loads</u>	<u>Devices, appliances and equipment connected to convenience receptacle outlets.</u>
<u>Process load</u>	<u>Any single load that is not included in an HVAC, lighting or plug load category and that exceeds 5 percent of the peak connected load of the whole building, including but not limited to data centers, manufacturing equipment and commercial kitchens.</u>
<u>Building operations and other miscellaneous loads</u>	<u>The remaining loads not included elsewhere in this table, including but not limited to vertical transportation systems, automatic doors, motorized shading systems, ornamental fountains, ornamental fireplaces, swimming pools, in-ground spas and snow-melt systems.</u>

**C405.12.3 Meters.** Meters or other measurement devices required by this section shall be configured to automatically communicate energy consumption data to the data acquisition system required by Section C405.12.4. Source meters shall be allowed to be any digital-type meter. Lighting, HVAC or other building systems that can monitor their energy consumption shall be permitted instead of meters. Current sensors shall be permitted, provided that they have a tested accuracy of ±2 percent. Required metering systems and equipment shall have the capability to provide at least hourly data that is fully integrated into the data acquisition system and graphical energy report in accordance with Sections C405.12.4 and C405.12.5.

**C405.12.4 Data acquisition system.** A data acquisition system shall have the capability to store the data from the required meters and other sensing devices for a minimum of 36 months. The data acquisition system shall have the capability to store real-time energy consumption data and provide hourly, daily, monthly and yearly logged data for each end-use category required by Section C405.12.2.

**C405.12.5 Graphical energy report.** A permanent reporting mechanism shall be provided in the building that is accessible to building operation and management personnel. The reporting mechanism shall have the capability to graphically provide the energy consumption for each end-use category required by Section C405.12.2 at least every hour, day, month and year for the previous 36 months.

**SECTION C406  
ADDITIONAL EFFICIENCY OPTIONS REQUIREMENTS**

**C406.1 Requirements.** Buildings shall comply with at least one of the following:

**C406.1 Additional energy efficiency credit requirements.** New buildings shall achieve a total of 10 credits from Tables C406.1(1) through C406.1(5) where the table is selected based on the use group of the building and from credit calculations as specified in relevant subsections of Section C406. Where a building contains multiple-use groups, credits from each use group shall be weighted by floor area of each group to determine the weighted average building credit. Credits from the tables or calculation shall be achieved where a building complies with one or more of the following:

1. More efficient HVAC performance in accordance with Section C406.2.
2. Reduced lighting power in accordance with Section C406.3.
3. Enhanced lighting controls in accordance with Section C406.4.
4. On-site supply of renewable energy in accordance with Section C406.5.
5. Provision of a dedicated outdoor air system for certain HVAC equipment in accordance with Section C406.6.
6. High-efficiency service water heating in accordance with Section C406.7.
7. Enhanced envelope performance in accordance with Section C406.8.
8. Reduced air infiltration in accordance with Section C406.9
9. Where not required by Section C405.12, include an energy monitoring system in accordance with Section C406.10.
10. Where not required by Section C403.2.3, include a fault detection and diagnostics (FDD) system in accordance with Section C406.11.
11. Efficient kitchen equipment in accordance with Section C406.12.

**C406.1.1 Tenant spaces.** Tenant spaces shall comply with Section C406.2, C406.3, C406.4, C406.6 or C406.7. Alternatively, tenant spaces shall comply with Section C406.5 where the entire building is in compliance.

**C406.1.1 Tenant spaces.** Tenant spaces shall comply with sufficient options from Tables C406.1(1) through C406.1(5) to achieve a minimum number of 5 credits, where credits are selected from Section C406.2, C406.3, C406.4, C406.6, C406.7 or C406.10. Where the entire building complies using credits from Section C406.5, C406.8 or C406.9, tenant spaces shall be deemed to comply with this section.

**Exception:** Previously occupied tenant spaces that comply with this code in accordance with Section C501.

**TABLE C406.1(1)**  
**ADDITIONAL ENERGY EFFICIENCY CREDITS FOR GROUP B OCCUPANCIES**

SECTION	CLIMATE ZONE																
	0A & 1A	0B & 1B	2A	2B	3A	3B	3C	4A	4B	4C	5A	5B	5C	6A	6B	7	8
C406.2.1: 5% heating efficiency improvement					NA			NA			1						
C406.2.2: 5% cooling efficiency improvement					4			3			2						
C406.2.3: 10% heating efficiency improvement					NA			NA			2						
C406.2.4: 10% cooling efficiency improvement					7			5			4						
C406.3: Reduced lighting power					9			8			7						
C406.4: Enhanced digital lighting controls					2			2			2						
C406.5: On-site renewable energy					9			9			9						
C406.6: Dedicated outdoor air					4			5			5						

<u>C406.7.2: Recovered or renewable water heating</u>				<u>NA</u>		<u>NA</u>		<u>NA</u>									
<u>C406.7.3: Efficient fossil fuel water heater</u>				<u>NA</u>		<u>NA</u>		<u>NA</u>									
<u>C406.7.4: Heat pump water heater</u>				<u>NA</u>		<u>NA</u>		<u>NA</u>									
<u>C406.8: Enhanced envelope performance</u>				<u>4</u>		<u>7</u>		<u>10</u>									
<u>C406.9: Reduced air infiltration</u>				<u>4</u>		<u>8</u>		<u>11</u>									
<u>C406.10: Energy monitoring</u>				<u>3</u>		<u>3</u>		<u>2</u>									
<u>C406.11: Fault detection and diagnostics system</u>				<u>1</u>		<u>1</u>		<u>1</u>									

NA = Not Applicable.

**TABLE C406.1(2)**  
**ADDITIONAL ENERGY EFFICIENCY CREDITS FOR GROUP R AND I OCCUPANCIES**

<u>SECTION</u>	<u>CLIMATE ZONE</u>																
	<u>0A &amp; 1A</u>	<u>0B &amp; 1B</u>	<u>2A</u>	<u>2B</u>	<u>3A</u>	<u>3B</u>	<u>3C</u>	<u>4A</u>	<u>4B</u>	<u>4C</u>	<u>5A</u>	<u>5B</u>	<u>5C</u>	<u>6A</u>	<u>6B</u>	<u>7</u>	<u>8</u>
<u>C406.2.1: 5% heating efficiency improvement</u>					<u>1</u>			<u>1</u>			<u>1</u>						
<u>C406.2.2: 5% cooling efficiency improvement</u>					<u>1</u>			<u>1</u>			<u>1</u>						
<u>C406.2.3: 10% heating efficiency improvement</u>					<u>1</u>			<u>1</u>			<u>2</u>						
<u>C406.2.4: 10% cooling efficiency improvement</u>					<u>2</u>			<u>2</u>			<u>1</u>						
<u>C406.3: Reduced lighting power</u>					<u>2</u>			<u>2</u>			<u>2</u>						
<u>C406.4: Enhanced digital lighting controls</u>					<u>NA</u>			<u>NA</u>			<u>NA</u>						
<u>C406.5: On-site renewable energy</u>					<u>7</u>			<u>7</u>			<u>7</u>						
<u>C406.6: Dedicated outdoor air system</u>					<u>4</u>			<u>6</u>			<u>8</u>						
<u>C406.7.2: Recovered or renewable water heating</u>					<u>13</u>			<u>14</u>			<u>14</u>						
<u>C406.7.3: Efficient fossil fuel water heater</u>					<u>8</u>			<u>8</u>			<u>9</u>						
<u>C406.7.4: Heat pump water heater</u>					<u>5</u>			<u>5</u>			<u>5</u>						
<u>C406.8: Enhanced envelope performance</u>					<u>4</u>			<u>4</u>			<u>4</u>						



<u>C406.9: Reduced air infiltration</u>				<u>6</u>				<u>7</u>					<u>9</u>					
<u>C406.10: Energy monitoring</u>				<u>1</u>				<u>1</u>					<u>1</u>					
<u>C406.11: Fault detection and diagnostics system</u>				<u>1</u>				<u>1</u>					<u>1</u>					

NA = Not Applicable.

**TABLE C406.1(3)**  
**ADDITIONAL ENERGY EFFICIENCY CREDITS FOR GROUP E OCCUPANCIES**

SECTION	CLIMATE ZONE																
	<u>0A &amp; 1A</u>	<u>0B &amp; 1B</u>	<u>2A</u>	<u>2B</u>	<u>3A</u>	<u>3B</u>	<u>3C</u>	<u>4A</u>	<u>4B</u>	<u>4C</u>	<u>5A</u>	<u>5B</u>	<u>5C</u>	<u>6A</u>	<u>6B</u>	<u>7</u>	<u>8</u>
<u>C406.2.1: 5% heating efficiency improvement</u>					<u>1</u>			<u>1</u>			<u>1</u>						
<u>C406.2.2: 5% cooling efficiency improvement</u>					<u>2</u>			<u>2</u>			<u>1</u>						
<u>C406.2.3: 10% heating efficiency improvement</u>					<u>1</u>			<u>2</u>			<u>3</u>						
<u>C406.2.4: 10% cooling efficiency improvement</u>					<u>5</u>			<u>4</u>			<u>2</u>						
<u>C406.3: Reduced lighting power</u>					<u>8</u>			<u>8</u>			<u>8</u>						
<u>C406.4: Enhanced digital lighting controls</u>					<u>2</u>			<u>2</u>			<u>2</u>						
<u>C406.5: On-site renewable energy</u>					<u>6</u>			<u>6</u>			<u>6</u>						
<u>C406.6: Dedicated outdoor air system</u>					<u>NA</u>			<u>NA</u>			<u>NA</u>						
<u>C406.7.2: Recovered or renewable water heating<sup>a</sup></u>					<u>1</u>			<u>1</u>			<u>1</u>						
<u>C406.7.3: Efficient fossil fuel water heater<sup>a</sup></u>					<u>1</u>			<u>2</u>			<u>2</u>						
<u>C406.7.4: Heat pump water heater<sup>a</sup></u>					<u>NA</u>			<u>1</u>			<u>1</u>						
<u>C406.8: Enhanced envelope performance</u>					<u>2</u>			<u>1</u>			<u>2</u>						
<u>C406.9: Reduced air infiltration</u>					<u>NA</u>			<u>NA</u>			<u>1</u>						
<u>C406.10: Energy monitoring</u>					<u>3</u>			<u>3</u>			<u>2</u>						
<u>C406.11: Fault detection and diagnostics system</u>					<u>1</u>			<u>1</u>			<u>1</u>						

NA = Not Applicable.

a. For schools with showers or full-service kitchens.

**TABLE C406.1(4)**  
**ADDITIONAL ENERGY EFFICIENCY CREDITS FOR GROUP M OCCUPANCIES**

SECTION	CLIMATE ZONE																
	0A & 1A	0B & 1B	2A	2B	3A	3B	3C	4A	4B	4C	5A	5B	5C	6A	6B	7	8
<u>C406.2.1: 5% heating efficiency improvement</u>					<u>1</u>			<u>1</u>			<u>2</u>						
<u>C406.2.2: 5% cooling efficiency improvement</u>					<u>3</u>			<u>2</u>			<u>1</u>						
<u>C406.2.3: 10% heating efficiency improvement</u>					<u>1</u>			<u>2</u>			<u>3</u>						
<u>C406.2.4: 10% cooling efficiency improvement</u>					<u>6</u>			<u>4</u>			<u>2</u>						
<u>C406.3: Reduced lighting power</u>					<u>16</u>			<u>15</u>			<u>12</u>						
<u>C406.4: Enhanced digital lighting controls</u>					<u>4</u>			<u>4</u>			<u>3</u>						
<u>C406.5: On-site renewable energy</u>					<u>8</u>			<u>8</u>			<u>7</u>						
<u>C406.6: Dedicated outdoor air system</u>					<u>3</u>			<u>3</u>			<u>2</u>						
<u>C406.7.2: Recovered or renewable water heating</u>					<u>NA</u>			<u>NA</u>			<u>NA</u>						
<u>C406.7.3: Efficient fossil fuel water heater</u>					<u>NA</u>			<u>NA</u>			<u>NA</u>						
<u>C406.7.4: Heat pump water heater</u>					<u>NA</u>			<u>NA</u>			<u>NA</u>						
<u>C406.8: Enhanced envelope performance</u>					<u>3</u>			<u>6</u>			<u>4</u>						
<u>C406.9: Reduced air infiltration</u>					<u>1</u>			<u>3</u>			<u>3</u>						
<u>C406.10: Energy monitoring</u>					<u>5</u>			<u>4</u>			<u>3</u>						
<u>C406.11: Fault detection and diagnostics system</u>					<u>1</u>			<u>1</u>			<u>1</u>						

NA = Not Applicable.

**TABLE C406.1(5)**  
**ADDITIONAL ENERGY EFFICIENCY CREDITS FOR OTHER<sup>a</sup> OCCUPANCIES**

SECTION	CLIMATE ZONE																
	0A & 1A	0B & 1B	2A	2B	3A	3B	3C	4A	4B	4C	5A	5B	5C	6A	6B	7	8
<u>C406.2.1: 5% heating efficiency improvement</u>					<u>1</u>			<u>1</u>			<u>1</u>						
<u>C406.2.2: 5% cooling efficiency improvement</u>					<u>3</u>			<u>2</u>			<u>1</u>						

<u>C406.2.3: 10% heating efficiency improvement</u>				<u>1</u>		<u>2</u>		<u>3</u>									
<u>C406.2.4: 10% cooling efficiency improvement</u>				<u>5</u>		<u>4</u>		<u>2</u>									
<u>C406.3: Reduced lighting power</u>				<u>9</u>		<u>8</u>		<u>7</u>									
<u>C406.4: Enhanced digital lighting controls</u>				<u>2</u>		<u>2</u>		<u>2</u>									
<u>C406.5: On-site renewable energy</u>				<u>8</u>		<u>8</u>		<u>7</u>									
<u>C406.6: Dedicated outdoor air system</u>				<u>4</u>		<u>5</u>		<u>5</u>									
<u>C406.7.2: Recovered or renewable water heating<sup>b</sup></u>				<u>13</u>		<u>14</u>		<u>14</u>									
<u>C406.7.3: Efficient fossil fuel water heater<sup>b</sup></u>				<u>8</u>		<u>8</u>		<u>9</u>									
<u>C406.7.4: Heat pump water heater<sup>b</sup></u>				<u>5</u>		<u>5</u>		<u>5</u>									
<u>C406.8: Enhanced envelope performance</u>				<u>3</u>		<u>5</u>		<u>5</u>									
<u>C406.9: Reduced air infiltration</u>				<u>4</u>		<u>6</u>		<u>6</u>									
<u>C406.10: Energy monitoring</u>				<u>3</u>		<u>3</u>		<u>2</u>									
<u>C406.11: Fault detection and diagnostics system</u>				<u>1</u>		<u>1</u>		<u>1</u>									

NA = Not Applicable.

a. Other occupancy groups include all groups except Groups B, E, I, M and R.

b. For occupancy groups listed in Section C406.7.1.

**C406.2 More efficient HVAC equipment performance.** Equipment shall exceed the minimum efficiency requirements listed in Tables C403.2.3(1) through C403.2.3(7) by 10 percent, in addition to the requirements of Section C403. Where multiple performance requirements are provided, the equipment shall exceed all requirements by 10 percent. *Variable refrigerant flow systems* shall exceed the energy efficiency provisions of ANSI/ASHRAE/IES 90.1 by 10 percent. Equipment not listed in Tables C403.2.3(1) through C403.2.3(7) shall be limited to 10 percent of the total building system capacity.

**Exemption:** Steam boilers are exempt from the additional 10 percent requirements.

**C406.2 More efficient HVAC equipment performance.** Equipment shall exceed the minimum efficiency requirements listed in the tables in Section C403.3.2. *Variable refrigerant flow systems* listed in the energy efficiency provisions of ANSI/ASHRAE/IES 90.1 in accordance with Section C406.2.1, C406.2.2, C406.2.3 or C406.2.4 shall also meet applicable requirements of Section C403. Energy efficiency credits for heating shall be selected from Section C406.2.1 or C406.2.3 and energy efficiency credits for cooling shall be selected from Section C406.2.2, C406.2.4 or C406.2.5. Selected credits shall include a heating or cooling energy efficiency credit or both. Equipment not listed in Tables C403.3.2(1) through C403.3.2(9) and *variable refrigerant flow systems* not listed in the energy efficiency provisions of ANSI/ASHRAE/IES 90.1 shall be limited to 10 percent of the total building system capacity for heating equipment where selecting Section C406.2.1 or C406.2.3 and cooling equipment where selecting Section C406.2.2, C406.2.4 or C406.2.5.

**C406.2.1 Five-percent heating efficiency improvement.** Equipment shall exceed the minimum heating efficiency requirements by 5 percent.

**C406.2.2 Five-percent cooling efficiency improvement.** Equipment shall exceed the minimum cooling and heat rejection efficiency requirements by 5 percent. Where multiple cooling performance requirements are provided, the equipment shall exceed the annual energy requirement, including IEER, SEER and IPLV.

**C406.2.3 Ten-percent heating efficiency improvement.** Equipment shall exceed the minimum heating efficiency requirements by 10 percent.

**C406.2.4 Ten-percent cooling efficiency improvement.** Equipment shall exceed the minimum cooling and heat rejection efficiency requirements by 10 percent. Where multiple cooling performance requirements are provided, the equipment shall exceed the annual energy requirement, including IEER, SEER and IPLV.

**C406.2.5 More than 10-percent cooling efficiency improvement.** Where equipment exceeds the minimum annual cooling and heat rejection efficiency requirements by more than 10 percent, energy efficiency credits for cooling may be determined using Equation 4-12, rounded to the nearest whole number. Where multiple cooling performance requirements are provided, the equipment shall exceed the annual energy requirement, including IEER, SEER and IPLV.

---

$$EEC_{HEC} = EEC_{10} [1 + ((CEI - 10 \text{ percent}) / 10 \text{ percent})]$$

**(Equation 4-12)**

where:

$EEC_{HEC}$  = Energy efficiency credits for cooling efficiency improvement.

$EEC_{10}$  = Section C406.2.4 credits from Tables C406.1(1) through C406.1(5).

$CEI$  = The lesser of: the improvement above minimum cooling and heat rejection efficiency requirements or 15 percent.

**C406.3 Reduced lighting power density.** The total interior lighting power (watts) of the building shall be determined by using 90 percent of the lighting power values specified in Table C405.4.2(1) times the floor area for the building types, or by using 90 percent of the interior lighting power allowance calculated by the Space-by-Space Method in Section C405.4.2.

**C406.3 Reduced lighting power by more than 10 percent.** Buildings shall comply with Section C406.3.1 or C406.3.2, and dwelling units and sleeping units within the building shall comply with Section C406.3.3.

**C406.3.1 Reduced lighting power by more than 10 percent.** The total connected interior lighting power calculated in accordance with Section C405.3.1 shall be less than 90 percent of the total lighting power allowance calculated in accordance with Section C405.3.2.

**C406.3.2 Reduced lighting power by more than 15 percent.** Where the total connected interior lighting power calculated in accordance with Section C405.3.1 is less than 85 percent of the total lighting power allowance calculated in accordance with Section C405.3.2, additional energy efficiency credits shall be determined based on Equation 4-13, rounded to the nearest whole number.

---

$$AEEC_{LPA} = AEEC_{10} \times 10 \times (LPA - LPD) / LPA$$

**(Equation 4-13)**

where:

$AEEC_{LPA}$  = Section C406.3.2 additional energy efficiency credits.

$AEEC_{10}$  = Section C406.3.1 credits from Tables C406.1(1) through C406.1(5).

$LPA$  = Total lighting power allowance calculated in accordance with Section C405.3.2.

$LPD$  = Total connected interior lighting power calculated in accordance with Section C405.3.1.

**C406.3.3 Lamp efficacy.** Not less than 95 percent of the permanently installed lighting, excluding kitchen appliance light fixtures, serving dwelling units and sleeping units shall be provided by lamps with an efficacy of not less than 65 lumens per watt or luminaires with an efficacy of not less than 45 lumens per watt.

**C406.4 Enhanced digital lighting controls.** Interior general lighting in the building shall have the following enhanced lighting controls that shall be located, scheduled and operated in accordance with Sections ~~C405.2.2~~ C405.2.1 through C405.2.3.

1. Luminaires shall be ~~capable of~~ configured for continuous dimming.
2. Luminaires shall be ~~capable of being~~ addressed individually. Where individual addressability is not available for the luminaire class type, a controlled group of not more than four luminaries shall be allowed.
3. Not more than eight luminaires shall be controlled together in a *daylight zone*.
4. Fixtures shall be controlled through a digital control system that includes the following function:
  - 4.1. Control reconfiguration based on digital addressability.
  - 4.2. Load shedding. □
  - ~~4.3 Individual user control of overhead general illumination in open offices.~~
  - 4.3. Occupancy sensors shall be capable of being reconfigured through the digital control system.
5. Construction documents shall include submittal of a Sequence of Operations, including a specification outlining each of the functions in Item 4.
6. Functional testing of lighting controls shall comply with Section C408.

**C406.5 On-site renewable energy.** ~~Total minimum ratings of on-site renewable energy systems shall comply with one of the following:~~

- ~~1. Provide not less than 0.50 watts per square foot (5.4 W/m<sup>2</sup>) of conditioned floor area.~~
- ~~2. Provide not less than 3 percent of the energy used within the building for building mechanical and service water-heating equipment and lighting regulated in Chapter 4.~~

**C406.5 On-site renewable energy.** Buildings shall comply with Section C406.5.1 or C406.5.2. □

**C406.5.1 Basic renewable credit.** The total minimum ratings of on-site renewable energy systems, not including systems used for credits under Sections C406.7.2, shall be one of the following:

1. Not less than 0.86 Btu/h per square foot (2.7 W/m<sup>2</sup>) or 0.25 watts per square foot (2.7 W/m<sup>2</sup>) of conditioned floor area.
2. Not less than 2 percent of the annual energy used within the building for building mechanical and service water-heating equipment and lighting regulated in Section C405.

**C406.5.2 Enhanced renewable credit.** Where the total minimum ratings of on-site renewable energy systems exceeds the rating in Section C406.5.1, additional energy efficiency credits shall be determined based on Equation 4-14, rounded to the nearest whole number.

$$\underline{AEEC_{RRa} = AEEC_{2.5} \times RRa/RR_1} \quad \text{(Equation 4-14)}$$

where:

$AEEC_{RRa}$  = Section C406.5.2 additional energy efficiency credits.

$AEEC_{2.5}$  = Section C406.5 credits from Tables C406.1(1) through C406.1(5).

$RRa$  = Actual total minimum ratings of *on-site renewable energy* systems (in Btu/h, watts per square foot or W/m<sup>2</sup>).

$RR_l$  = Minimum ratings of on-site renewable energy systems required by Section C406.5.1 (in Btu/h, watts per square foot or W/m<sup>2</sup>).

~~**C406.6 Dedicated outdoor air system.** Buildings covered by Section C403.4 shall be equipped with an independent ventilation system designed to provide not less than the minimum 100-percent outdoor air to each individual occupied space, as specified by the *International Mechanical Code*. The ventilation system shall be capable of recovering both sensible and latent energy.~~

**C406.6 Dedicated outdoor air system.** Buildings containing equipment or systems regulated by Section C403.3.4, C403.4.3, C403.4.4, C403.4.5, C403.6, C403.8.4, C403.8.6, C403.8.6.1, C403.10.1, C403.10.2, C403.10.3 or C403.10.4 shall be equipped with an independent ventilation system designed to provide not less than the minimum 100-percent outdoor air to each individual occupied space, as specified by the *International Mechanical Code*. The ventilation system shall be capable of total energy recovery. The HVAC system shall include supply-air temperature controls that automatically reset the supply-air temperature in response to representative building loads or to outdoor air temperatures. The controls shall reset the supply-air temperature not less than 25 percent of the difference between the design supply-air temperature and the design room-air temperature.

~~**C406.7 Reduced energy use in service water heating.**~~

~~Buildings shall be of the following types to use this compliance method:~~

- ~~1. Group R-1: Boarding houses, hotels or motels.~~
- ~~2. Group I-2: Hospitals, psychiatric hospitals and nursing homes.~~
- ~~3. Group A-2: Restaurants and banquet halls or buildings containing food preparation areas.~~
- ~~4. Group F: Laundries.~~
- ~~5. Group R-2: Buildings with residential occupancies.~~
- ~~6. Group A-3: Health clubs and spas.~~
- ~~7. Buildings showing a service hot water load of 10 percent or more of total building energy loads, as shown with an energy analysis as described in Section C407.~~

**C406.7 Reduced energy use in service water heating.** Buildings shall comply with Section C406.7.1 and Section C406.7.2, C406.7.3 or C406.7.4. □

~~**C406.7.1 Load fraction.** The building service water heating system shall have one or more of the following that are sized to provide not less than 60 percent of hot water requirements:~~

- ~~1. Waste heat recovery from service hot water, heat recovery chillers, building equipment, process equipment, or a combined heat and power system.~~
- ~~2. Solar water heating systems.~~
- ~~3. Instantaneous fuel-fired water heating systems for all fuel-fired water heating systems.~~
- ~~4. Electric heat pump water heating systems.~~
- ~~5. Water heating provided by geothermal heat pumps.~~

**C406.7.1 Building type.** To qualify for this credit, the building shall contain one of the following use groups, and the additional energy efficiency credit shall be prorated by conditioned floor area of the portion of the building comprised of the following use groups:

1. Group R-1: Boarding houses, hotels or motels.
2. Group I-2: Hospitals, psychiatric hospitals and nursing homes.

3. Group A-2: Restaurants and banquet halls or buildings containing food preparation areas.
4. Group F: Laundries.
5. Group R-2.
6. Group A-3: Health clubs and spas.
7. Group E: Schools with full-service kitchens or locker rooms with showers.
8. Buildings showing a service hot water load of 10 percent or more of total building energy loads, as shown with an energy analysis as described in Section C407.

**C406.7.2 Recovered or renewable water heating.** The building service water-heating system shall have one or more of the following that are sized to provide not less than 30 percent of the building's annual hot water requirements, or sized to provide 70 percent of the building's annual hot water requirements if the building is required to comply with Section C403.10.5:

1. Waste heat recovery from service hot water, heat-recovery chillers, building equipment or process equipment.
2. On-site renewable energy water-heating systems.

**C406.7.3 Efficient fossil fuel water heater.** The combined input-capacity weighted-average equipment rating of all fossil fuel water-heating equipment in the building shall be not less than 95 percent Et or 0.95 EF. This option shall receive only half the listed credits for buildings required to comply with Section C404.2.1.

**C406.7.4 Heat pump water heater.** Where electric resistance water heaters are allowed, all service hot water system heating requirements shall be met using heat pump technology with a combined input-capacity weighted-average EF of 3.0. Air-source heat pump water heaters shall not draw conditioned air from within the building, except exhaust air that would otherwise be exhausted to the exterior.

**C406.8 Enhanced envelope performance.** The total UA of the *building thermal envelope* as designed shall be not less than 15 percent below the total UA of the *building thermal envelope* in accordance with Section C402.1.5.

**C406.9 Reduced air infiltration.** Air infiltration shall be verified by whole building pressurization testing conducted in accordance with ASTM E779 or ASTM E1827 by an independent third party. The measured air leakage rate of the building envelope shall not exceed 0.25 cfm/ft<sup>2</sup> (2.0 L/s × m<sup>2</sup>) under a pressure differential of 0.3 inches water column (75 Pa), with the calculated surface area being the sum of the above- and below-grade building envelope. A report that includes the tested surface area, floor area, air by volume, stories above grade, and leakage rates shall be submitted to the code official and the building owner.

**Exception:** For buildings having over 250,000 square feet (25 000 m<sup>2</sup>) of *conditioned floor area*, air leakage testing need not be conducted on the whole building where testing is conducted on representative above-grade sections of the building. Tested areas shall total not less than 25 percent of the conditioned floor area and shall be tested in accordance with this section.

**C406.9 Reduced air leakage.** Air leakage of the *building thermal envelope* shall be tested by an *approved* third party in accordance with Section C402.5.2.1. The measured *air leakage* shall not exceed 0.22 cfm/ft<sup>2</sup> (1.1 L/s × m<sup>2</sup>) of the *building thermal envelope* at a pressure differential of 0.3 inch water gauge (75 Pa), with the calculated surface area being the sum of the above- and below-grade *building thermal envelope*.

**Exception:** Buildings tested in accordance with C402.5.2 where the weighted average of all tested unit results is not greater than 0.15 cfm/ft<sup>2</sup> (1.0 L/s × m<sup>2</sup>) at a pressure differential of 0.2 inch water gauge (50 Pa), or 0.20 cfm/ft<sup>2</sup> at a pressure differential of 75Pa (0.30 in w.g.) in accordance with Table C406.9.

**Table C406.9**

Pressure Differential (Pa)	Test pressure Adjustment Factor	Max Air Leakage / Building Thermal Envelope (CFM / ft <sup>2</sup> )	
		75 (0.30 in. w.g.)	
50 (0.20 in. w.g.)	0.752897957	0.15	0.17
Example: If maximum air leakage allowed is 0.15 cfm/ft <sup>2</sup> of bldg thermal envelope at 50 Pa(0.2 in w.g.), the corresponding maximum leakage rate is 0.20 cfm/SF of bldg thermal envelope if using a higher test pressure of 75 Pa(0.3 in w.g.)			

**C406.9 Reduced air leakage. Air leakage of the building thermal envelope shall be tested by an approved third party in accordance with Section C402.5.2.1 and shall comply with one of the following:**

- 1. The measured air leakage shall not exceed 0.22 cfm/ft<sup>2</sup> (1.1 L/s × m<sup>2</sup>) of the building thermal envelope at a pressure differential of 0.3 inch water gauge (75 Pa), with the calculated surface area being the sum of the above- and below-grade building thermal envelope. Exception:**
- 2. Buildings tested in accordance with C402.5.2 shall have a weighted average of all tested unit results that is not greater than 0.15 cfm/ft<sup>2</sup> (1.0 L/s x m<sup>2</sup>) at a pressure differential of 0.2 inch water gauge (50 Pa), or 0.20 cfm/ft<sup>2</sup> at a pressure differential of 75Pa (0.30 in w.g.) in accordance with Table C406.9.**

**C406.10 Energy monitoring.** Buildings shall be equipped to measure, monitor, record and report energy consumption data in compliance with Sections C406.10.1 through C406.10.5.

**C406.10.1 Electrical energy metering.** For all electrical energy supplied to the building and its associated site, including but not limited to site lighting, parking, recreational facilities, and other areas that serve the building and its occupants, meters or other measurement devices shall be provided to collect energy consumption data for each end-use category required by Section C406.10.2.

**C406.10.2 End-use metering categories.** Meters or other *approved* measurement devices shall be provided to collect energy use data for each end-use category listed in Table 406.10.2. These meters shall have the capability to collect energy consumption data for the whole building or for each separately metered portion of the building. Where multiple meters are used to measure any end-use category, the data acquisition system shall total all of the energy used by that category. Not more than 5 percent of the measured load for each of the end-use categories listed in Table 406.10.2 is permitted to be from a load not within the category.

**Exceptions:**

- 1. HVAC and water-heating equipment serving only an individual dwelling unit does not require end-use metering.**
- 2. End-use metering is not required for fire pumps, stairwell pressurization fans or any system that operates only during testing or emergency.**



**TABLE C406.10.2**  
**ENERGY USE CATEGORIES**

LOAD CATEGORY	DESCRIPTION OF ENERGY USE
<u>Total HVAC system</u>	<u>Heating, cooling and ventilation, including but not limited to fans, pumps, boilers, chillers and water heating. Energy used by 120-volt equipment, or by 208/120-volt equipment that is located in a building where the main service is 480/277-volt power, is permitted to be excluded from total HVAC system energy use.</u>
<u>Interior lighting</u>	<u>Lighting systems located within the building.</u>
<u>Exterior lighting</u>	<u>Lighting systems located on the building site but not within the building.</u>
<u>Plug loads</u>	<u>Devices, appliances and equipment connected to convenience receptacle outlets.</u>
<u>Process loads</u>	<u>Any single load that is not included in an HVAC, lighting or plug load category and that exceeds 5 percent of the peak connected load of the whole building, including but not limited to data centers, manufacturing equipment and commercial kitchens.</u>
<u>Building operations and other miscellaneous loads</u>	<u>The remaining loads not included elsewhere in this table, including but not limited to vertical transportation systems and automatic doors.</u>

**C406.10.3 Meters.** Meters or other measurement devices required by this section shall be configured to automatically communicate energy consumption data to the data acquisition system required by Section C406.10.4. Source meters shall be allowed to be any digital-type meter. Lighting, HVAC or other building systems that can monitor their energy consumption shall be permitted instead of meters. Current sensors shall be permitted, provided that they have a tested accuracy of  $\pm 2$  percent. Required metering systems and equipment shall have the capability to provide at least hourly data that is fully integrated into the data acquisition system and graphical energy report in accordance with Sections C406.10.4 and C406.10.5.

**C406.10.4 Data acquisition system.** A data acquisition system shall have the capability to store the data from the required meters and other sensing devices for a minimum of 36 months. The data acquisition system shall have the capability to store real-time energy consumption data and provide hourly, daily, monthly and yearly logged data for each end-use category required by Section C406.10.2.

**C406.10.5 Graphical energy report.** A permanent reporting mechanism shall be provided in the building that is accessible by building operation and management personnel. The reporting mechanism shall have the capability to graphically provide the energy consumption for each end-use category required by Section C406.10.2 at least every hour, day, month and year for the previous 36 months.

**C406.11 Fault detection and diagnostics system.** A fault detection and diagnostics system shall be installed to monitor the HVAC system’s performance and automatically identify faults. The system shall do all of the following:

1. Include permanently installed sensors and devices to monitor the HVAC system’s performance.

2. [Deleted from proposed 2024 Code, no 2018 equivalent.]
3. Automatically identify and report HVAC system faults.
4. Automatically notify authorized personnel of identified HVAC system faults.
5. Automatically provide prioritized recommendations for repair of identified faults based on analysis of data collected from the sampling of the HVAC system performance.
6. Be capable of transmitting the prioritized fault repair recommendations to remotely located authorized personnel.

**C406.12 Efficient kitchen equipment.** For buildings and spaces designated as Group A-2 or facilities that include a commercial kitchen with at least one gas or electric fryer, all fryers, dishwashers, steam cookers and ovens shall comply with all of the following:

1. Achieve performance levels in accordance with the equipment specifications listed in Tables C406.12(1) through C406.12(4) when rated in accordance with the applicable test procedure.
2. Be installed prior to the issuance of the Certificate of Occupancy.
3. Have associated performance levels listed on the construction documents submitted for permitting.

Energy efficiency credits for efficient kitchen equipment shall be independent of climate zone and determined based on Equation 4-15, rounded to the nearest whole number.

$$AEEC_K = 20 \times Area_K / Area_B \quad \text{(Equation 4-15)}$$

where:

$AEEC_K$  = Section C406.12 additional energy efficiency credits.

$Area_K$  = Floor area of full-service kitchen (ft<sup>2</sup> or m<sup>2</sup>).

$Area_B$  = Gross floor area of building (ft<sup>2</sup> or m<sup>2</sup>).

**TABLE C406.12(1)**  
**MINIMUM EFFICIENCY REQUIREMENTS:**  
**COMMERCIAL FRYERS**

FRYER TYPE	HEAVY-LOAD COOKING ENERGY EFFICIENCY	IDLE ENERGY RATE	TEST PROCEDURE
Standard open deep-fat gas fryers	≥ 50%	≤ 9,000 Btu/h	ASTM F1361
Standard open deep-fat electric fryers	≥ 83%	≤ 800 watts	
Large-vat open deep-fat gas fryers	≥ 50%	≤ 12,000 Btu/h	ASTM F2144
Large-vat open deep-fat electric fryers	≥ 80%	≤ 1,100 watts	

For SI: 1 Btu/h = 0.293/W.

**TABLE C406.12(2)**  
**MINIMUM EFFICIENCY REQUIREMENTS: COMMERCIAL STEAM COOKERS**

FUEL TYPE	PAN CAPACITY	COOKING ENERGY EFFICIENCY <sup>a</sup>	IDLE ENERGY RATE	TEST PROCEDURE
-----------	--------------	--	------------------	----------------

<u>Electric steam</u>	<u>3-pan</u>	<u>50%</u>	<u>=</u>	<u>ASTM F1484</u>
	<u>4-pan</u>	<u>50%</u>	<u>=</u>	
	<u>5-pan</u>	<u>50%</u>	<u>=</u>	
	<u>6-pan and larger</u>	<u>50%</u>	<u>=</u>	
<u>Gas steam</u>	<u>3-pan</u>	<u>38%</u>	<u>=</u>	
	<u>4-pan</u>	<u>38%</u>	<u>=</u>	
	<u>5-pan</u>	<u>38%</u>	<u>=</u>	
	<u>6-pan and larger</u>	<u>38%</u>	<u>=</u>	

a. Cooking energy efficiency is based on heavy load (potato) cooking capacity.

**TABLE C406.12(3)**

**MINIMUM EFFICIENCY REQUIREMENTS: COMMERCIAL DISHWASHERS**

<u>MACHINE TYPE</u>	<u>HIGH-TEMPERATURE EFFICIENCY REQUIREMENTS</u>		<u>LOW-TEMPERATURE EFFICIENCY REQUIREMENTS</u>		<u>TEST PROCEDURE</u>
	<u>Idle energy rate<sup>a</sup></u>	<u>Water consumption<sup>b</sup></u>	<u>Idle energy rate<sup>a</sup></u>	<u>Water consumption<sup>b</sup></u>	
<u>Under counter</u>	<u>≤ 50 kW</u>	<u>≤ 0.86 GPR</u>	<u>≤ 0.50 kW</u>	<u>≤ 1.19 GPR</u>	<u>ASTM F1696</u> <u>ASTM F1920</u>
<u>Stationary single-tank door</u>	<u>≤ 70 kW</u>	<u>≤ 0.89 GPR</u>	<u>≤ 0.60 kW</u>	<u>≤ 1.18 GPR</u>	
<u>Pot, pan and utensil</u>	<u>≤ 1.20 kW</u>	<u>≤ 0.58 GPR</u>	<u>≤ 1.00 kW</u>	<u>≤ 0.58 GPSF</u>	
<u>Single-tank conveyor</u>	<u>≤ 1.50 kW</u>	<u>≤ 0.70 GPR</u>	<u>≤ 1.50 kW</u>	<u>≤ 0.79 GPR</u>	
<u>Multiple-tank conveyor</u>	<u>≤ 2.25 kW</u>	<u>≤ 0.54 GPR</u>	<u>≤ 2.00 kW</u>	<u>≤ 0.54 GPR</u>	
<u>Single-tank flight</u>	<u>Reported</u>	<u><math>\frac{GPH \leq 2.975x + 55.00}{55.00}</math></u>	<u>Reported</u>	<u><math>\frac{GPH \leq 2.975x + 55.00}{55.00}</math></u>	
<u>Multiple-tank flight</u>	<u>Reported</u>	<u><math>GPH \leq 4.96x + 17.00</math></u>	<u>Reported</u>	<u><math>GPH \leq 4.96x + 17.00</math></u>	

a. Idle results shall be measured with the door closed and represent the total idle energy consumed by the machine, including all tank heaters and controls. Booster heater (internal or external) energy consumption shall not be part of this measurement unless it cannot be separately monitored.

b. GPR = gallons per rack, GPSF = gallons per square foot of rack, GPH = gallons per hour,  $x$  = maximum conveyer belt speed (feet/minute) × conveyer belt width (feet).

**TABLE C406.12(4)**

**MINIMUM EFFICIENCY REQUIREMENTS: COMMERCIAL OVENS**

<u>FUEL TYPE</u>	<u>CLASSIFICATION</u>	<u>IDLE RATE</u>	<u>COOKING-ENERGY EFFICIENCY, %</u>	<u>TEST PROCEDURE</u>
<u>Convection ovens</u>				
<u>Gas</u>	<u>Full-size</u>	<u>≤ 12,000 Btu/h</u>	<u>≥ 46</u>	<u>ASTM F1496</u>
<u>Electric</u>	<u>Half-size</u>	<u>≤ 1.0 Btu/h</u>	<u>≥ 71</u>	
	<u>Full-size</u>	<u>≤ 1.60 Btu/h</u>		
<u>Combination ovens</u>				
<u>Gas</u>	<u>Steam mode</u>	<u>≤ 200P<sup>a</sup> + 6,511 Btu/h</u>	<u>≥ 41</u>	<u>ASTM F2861</u>

	<u>Convection mode</u>	$\leq 150P^a + 5,425 \text{ Btu/h}$	$\geq 56$	
<u>Electric</u>	<u>Steam mode</u>	$\leq 0.133P^a + 0.6400 \text{ kW}$	$\geq 55$	
	<u>Convection mode</u>	$\leq 0.080P^a + 0.4989 \text{ kW}$	$\geq 76$	
<b>Rack ovens</b>				
<u>Gas</u>	<u>Single</u>	$\leq 25,000 \text{ Btu/h}$	$\geq 48$	<u>ASTM F2093</u>
	<u>Double</u>	$\leq 30,000 \text{ Btu/h}$	$\geq 52$	

For SI: 1 Btu/h = 0.293/W.

a.  $P$  = Pan Capacity: the number of steam table pans the combination oven is able to accommodate in accordance with ASTM F1495.

## SECTION C407 TOTAL BUILDING PERFORMANCE

**C407.1 Scope.** This section establishes criteria for compliance using total building performance. The following systems and loads shall be included in determining the total building performance: heating systems, cooling systems, service water heating, fan systems, lighting power, receptacle loads and process loads.

**Exception:** Energy used to recharge or refuel vehicles that are used for on-road and off-site transportation purposes. □

**C407.2 Mandatory requirements.** Compliance based on total building performance requires that ~~the criteria of Sections C402.5, C403.2, C404 and C405 be met.~~ A proposed design meet all of the following:

1. The requirements of the sections indicated within Table C407.2.
2. An annual energy cost that is less than or equal to 85 percent of the annual energy cost of the *standard reference design*. Energy prices shall be taken from a source approved by the code official, such as the Department of Energy, Energy Information Administration's *State Energy Data System Prices and Expenditures* reports. Code officials shall be permitted to require time-of-use pricing in energy cost calculations. The reduction in energy cost of the proposed design associated with *on-site renewable energy* shall be not more than 5 percent of the total energy cost. The amount of renewable energy purchased from off-site sources shall be the same in the *standard reference design* and the *proposed design*.

**Exception:** Jurisdictions that require site energy (1 kWh = 3413 Btu) rather than energy cost as the metric of comparison.

**TABLE C407.2  
REQUIREMENTS FOR TOTAL BUILDING PERFORMANCE**

SECTION <sup>a</sup>	TITLE
<b>Envelope</b>	
<u>C402.5</u>	<u>Air leakage—thermal envelope</u>
<b>Mechanical</b>	
<u>C403.1.1</u>	<u>Calculation of heating and cooling loads</u>
<u>C403.1.2</u>	<u>Data centers</u>

<u>C403.2</u>	<u>System design</u>
<u>C403.3</u>	<u>Heating and cooling equipment efficiencies</u>
<u>C403.4, except C403.4.3, C403.4.4 and C403.4.5</u>	<u>Heating and cooling system controls</u>
<u>C403.5.5</u>	<u>Economizer fault detection and diagnostics</u>
<u>C403.7, except C403.7.4.1</u>	<u>Ventilation and exhaust systems</u>
<u>C403.8, except C403.8.6</u>	<u>Fan and fan controls</u>
<u>C403.9</u>	<u>Large-diameter ceiling fans</u>
<u>C403.11, except C403.11.3</u>	<u>Refrigeration equipment performance</u>
<u>C403.12</u>	<u>Construction of HVAC system elements</u>
<u>C403.13</u>	<u>Mechanical systems located outside of the building thermal envelope</u>
<u>C404</u>	<u>Service water heating</u>
<u>C405, except C405.3</u>	<u>Electrical power and lighting systems</u>
<u>C408</u>	<u>Maintenance information and system commissioning</u>

a. Reference to a code section includes all the relative subsections except as indicated in the table.

**€407.4 C407.3 Documentation.** Documentation verifying that the methods and accuracy of compliance software tools conform to the provisions of this section shall be provided to the *code official*.

**€407.4.1 C407.3.1 Compliance report.** Permit submittals shall include a report documenting that the proposed design has annual energy costs less than or equal to the annual energy costs of the standard reference design. The compliance documentation shall include the following information:

1. Address of the building.
2. An inspection checklist documenting the building component characteristics of the *proposed design* as specified in Table C407.4.1(1). The inspection checklist shall show the estimated annual energy cost for both the *standard reference design* and the *proposed design*.
3. Name of individual completing the compliance report.
4. Name and version of the compliance software tool.

**€407.4.2 C407.3.2 Additional documentation.** The *code official* shall be permitted to require the following documents:

1. Documentation of the building component characteristics of the *standard reference design*.
2. Thermal zoning diagrams consisting of floor plans showing the thermal zoning scheme for *standard reference design* and *proposed design*.
3. Input and output reports from the energy analysis simulation program containing the complete input and output files, as applicable. The output file shall include energy use totals and energy use by energy source and end-use served, total hours that space conditioning loads are not met and any errors or warning messages generated by the simulation tool as applicable.
4. An explanation of any error or warning messages appearing in the simulation tool output.

5. A certification signed by the builder providing the building component characteristics of the *proposed design* as given in Table C407.4.1(1).
6. Documentation of the reduction in energy use associated with *on-site renewable energy*.

**€407.5 C407.4 Calculation procedure.** Except as specified by this section, the *standard reference design* and *proposed design* shall be configured and analyzed using identical methods and techniques.

**€407.5.1 C407.4.1 Building specifications.** The *standard reference design* and *proposed design* shall be configured and analyzed as specified by Table ~~€407.5.1(4)~~ C407.4.1(1). Table ~~€407.5.1(4)~~ C407.4.1(1) shall include by reference all notes contained in Table C402.1.4.

**€407.5.2 C407.4.2 Thermal blocks.** The *standard reference design* and *proposed design* shall be analyzed using identical thermal blocks as specified in Section C407.4.2.1, C407.4.2.2 or C407.4.2.3.

**€407.5.2.1 C407.4.2.1 HVAC zones designed.** Where HVAC *zones* are defined on HVAC design drawings, each HVAC *zone* shall be modeled as a separate thermal block.

**Exception:** Different HVAC *zones* shall be allowed to be combined to create a single thermal block or identical thermal blocks to which multipliers are applied, provided that:

1. The space use classification is the same throughout the thermal block.
2. All HVAC *zones* in the thermal block that are adjacent to glazed exterior walls face the same orientation or their orientations are within 45 degrees (0.79 rad) of each other.
3. All of the *zones* are served by the same HVAC system or by the same kind of HVAC system.

**€407.5.2.2 C407.4.2.2 HVAC zones not designed.** Where HVAC *zones* have not yet been designed, thermal blocks shall be defined based on similar internal load densities, occupancy, lighting, thermal and temperature schedules, and in combination with the following guidelines:

1. Separate thermal blocks shall be assumed for interior and perimeter spaces. Interior spaces shall be those located more than 15 feet (4572 mm) from an exterior wall. Perimeter spaces shall be those located closer than 15 feet (4572 mm) from an *exterior wall*.
2. Separate thermal blocks shall be assumed for spaces adjacent to glazed exterior walls: a separate *zone* shall be provided for each orientation, except orientations that differ by not more than 45 degrees (0.79 rad) shall be permitted to be considered to be the same orientation. Each *zone* shall include floor area that is 15 feet (4572 mm) or less from a glazed perimeter wall, except that floor area within 15 feet (4572 mm) of glazed perimeter walls having more than one orientation shall be divided proportionately between *zones*.
3. Separate thermal blocks shall be assumed for spaces having floors that are in contact with the ground or exposed to ambient conditions from *zones* that do not share these features.
4. Separate thermal blocks shall be assumed for spaces having exterior ceiling or roof assemblies from *zones* that do not share these features.

**~~€407.5.2.3 Multifamily residential buildings.~~ C407.4.2.3 Group R-2 occupancy buildings.** Group R-2 occupancy spaces shall be modeled using one thermal block per space except that those facing the same orientations are permitted to be combined into one thermal block. Corner units and units with roof or floor loads shall only be combined with units sharing these features.

**TABLE €407.5.1(4) C407.4.1(1)  
SPECIFICATIONS FOR THE STANDARD REFERENCE AND PROPOSED DESIGNS**

BUILDING COMPONENT CHARACTERISTICS	STANDARD REFERENCE DESIGN	PROPOSED DESIGN

Space use classification	Same as proposed	The space use classification shall be chosen in accordance with Table C405.3.2(1) or C405.3.2(2) for all areas of the building covered by this permit. Where the space use classification for a building is not known, the building shall be categorized as an office building.
Roofs	Type: insulation entirely above deck	As proposed
	Gross area: same as proposed	As proposed
	<i>U</i> -factor: as specified in Table C402.1.4	As proposed
	Solar absorptance: 0.75	As proposed
	Emittance: 0.90	As proposed
Walls, above-grade	Type: <del>Mass wall</del> , same as proposed	As proposed
	Gross area: same as proposed	As proposed
	<i>U</i> -factor: as specified in Table C402.1.4	As proposed
	Solar absorptance: 0.75	As proposed
	Emittance: 0.90	As proposed
Walls, below-grade	Type: mass wall	As proposed
	Gross area: same as proposed	As proposed
	<i>U</i> -Factor: as specified in Table C402.1.4 with insulation layer on interior side of walls	As proposed
Floors, above-grade	Type: joist/framed floor	As proposed
	Gross area: same as proposed	As proposed
	<i>U</i> -factor: as specified in Table C402.1.4	As proposed
Floors, slab-on-grade	Type: unheated	As proposed
	<i>F</i> -factor: as specified in Table C402.1.4	As proposed
Opaque doors	Type: swinging	As proposed
	Area: Same as proposed	As proposed
	<i>U</i> -factor: as specified in Table C402.1.4	As proposed
Vertical fenestration other than opaque doors	Area <ul style="list-style-type: none"> <li>1. The proposed vertical fenestration area; where the proposed <del>glazing vertical fenestration</del> area is less than 40 percent of above-grade wall area.</li> <li>2. 40 percent of above-grade wall area; where the proposed <del>glazing vertical fenestration</del> area is 40 percent or more of the above-grade wall area.</li> </ul>	As proposed
	<i>U</i> -factor: as specified in Table C402.4	As proposed
	SHGC: as specified in Table C402.4 except that for climates with no requirement (NR) SHGC = 0.40 shall be used	As proposed
	External shading and PF: none	As proposed

(continued)

**Table C407.5.1(4) TABLE C407.4.1(1)—continued**

**SPECIFICATIONS FOR THE STANDARD REFERENCE AND PROPOSED DESIGNS**

BUILDING COMPONENT CHARACTERISTICS	STANDARD REFERENCE DESIGN	PROPOSED DESIGN
Skylights	Area 1. The proposed skylight area; where the proposed skylight area is less than <del>3% of gross area of roof assembly that permitted by Section C402.1.</del> 2. <del>3% of gross area of roof assembly; The area permitted by Section C402.1; where the proposed skylight area is 3% or more of gross area of roof assembly exceeds that permitted by Section C402.1.</del>	As proposed
	U-factor: as specified in Table C402.4	As proposed
	SHGC: as specified in Table C402.4 except that for climates with no requirement (NR) SHGC = 0.40 shall be used.	As proposed
Lighting, interior	The interior lighting power shall be determined in accordance with Section C405.3.2. Where the occupancy of the building is not known, the lighting power density shall be 1.0 watt per square foot based on the categorization of buildings with unknown space classification as offices.	As proposed
Lighting, exterior	The lighting power shall be determined in accordance with Tables C405.5.2(1), C405.5.2(2) and C405.5.2(3). Areas and dimensions of surfaces shall be the same as proposed.	As proposed
Internal gains	Same as proposed	Receptacle, motor and process loads shall be modeled and estimated based on the space use classification. End-use load components within and associated with the building shall be modeled to include, but not be limited to, the following: exhaust fans, parking garage ventilation fans, exterior building lighting, swimming pool heaters and pumps, elevators, escalators, refrigeration equipment and cooking equipment.
Schedules	Same as proposed <u>Exception: Thermostat settings and schedules for HVAC systems that utilize radiant heating, radiant cooling and elevated air speed, provided that equivalent levels of occupant thermal comfort are demonstrated by means of equal Standard Effective Temperature as calculated in Normative Appendix B of ASHRAE Standard 55.</u>	Operating schedules shall include hourly profiles for daily operation and shall account for variations between weekdays, weekends, holidays and any seasonal operation. Schedules shall model the time-dependent variations in occupancy, illumination, receptacle loads, thermostat settings, mechanical ventilation, HVAC equipment availability, service hot water usage and any process loads. The schedules shall be typical of the proposed building type as determined by the designer and approved by the jurisdiction.
Mechanical ventilation	Same as proposed	As proposed, in accordance with Section C403.2.2.
Heating systems	Fuel type: same as proposed design	As proposed
	Equipment type <sup>a</sup> : as specified in Tables C407.4.1(2) and C407.4.1(3)	As proposed
	Efficiency: as specified in the tables in Section <del>C403.2.3</del> <u>C403.3.2.</u>	As proposed



	Capacity <sup>b</sup> : sized proportionally to the capacities in the proposed design based on sizing runs, and shall be established such that no smaller number of unmet heating load hours and no larger heating capacity safety factors are provided than in the proposed design.	As proposed
--	--	-------------

(continued)

~~Table C407.5.1(1)~~ **TABLE C407.4.1(1)**—continued

**SPECIFICATIONS FOR THE STANDARD REFERENCE AND PROPOSED DESIGNS**

BUILDING COMPONENT CHARACTERISTICS	STANDARD REFERENCE DESIGN	PROPOSED DESIGN
Cooling systems	Fuel type: same as proposed design	As proposed
	Equipment type <sup>c</sup> : as specified in Tables C407.4.1(2) and C407.4.1(3)	As proposed
	Efficiency: as specified in Tables C403.3.2(1), C403.3.2(2) and C403.3.2(3)	As proposed
	Capacity <sup>b</sup> : sized proportionally to the capacities in the proposed design based on sizing runs, and shall be established such that no smaller number of unmet cooling load hours and no larger cooling capacity safety factors are provided than in the proposed design.	As proposed
	Economizer <sup>d</sup> : same as proposed, in accordance with Section C403.5.	As proposed
Service water heating <sup>e</sup>	Fuel type: same as proposed	As proposed
	Efficiency: as specified in Table C404.2	For <i>Group R</i> , as proposed multiplied by SWHF. For other than <i>Group R</i> , as proposed multiplied by efficiency as provided by the manufacturer of the DWHR unit.
	Capacity: same as proposed	As proposed
	Where no service water hot water system exists or is specified in the proposed design, no service hot water heating shall be modeled.	

For SI: 1 watt per square foot = 10.7 w/m<sup>2</sup>.

SWHF = Service Water Heat Recovery factor, DWHR = Drain Water Heat Recovery.

- a. Where no heating system exists or has been specified, the heating system shall be modeled as fossil fuel. The system characteristics shall be identical in both the standard reference design and proposed design.
- b. The ratio between the capacities used in the annual simulations and the capacities determined by sizing runs shall be the same for both the standard reference design and proposed design.
- c. Where no cooling system exists or no cooling system has been specified, the cooling system shall be modeled as an air-cooled single-zone system, one unit per thermal zone. The system characteristics shall be identical in both the standard reference design and proposed design.
- d. If an economizer is required in accordance with Table C403.5(1) and where no economizer exists or is specified in the proposed design, then a supply-air economizer shall be provided in the standard reference design in accordance with Section C403.5.
- e. The SWHF shall be applied as follows:
  1. Where potable water from the DWHR unit supplies not less than one shower and not greater than two showers, of which the drain water from the same showers flows through the DWHR unit then  $SWHF = [1 - (DWHR \text{ unit efficiency} \times 0.36)]$ .
  2. Where potable water from the DWHR unit supplies not less than three showers and not greater than four showers, of which the drain water from the same showers flows through the DWHR unit then  $SWHF = [1 - (DWHR \text{ unit efficiency} \times 0.33)]$ .
  3. Where potable water from the DWHR unit supplies not less than five showers and not greater than six showers, of which the drain water from the same showers flows through the DWHR unit, then  $SWHF = [1 - (DWHR \text{ unit efficiency} \times 0.26)]$ .
  4. Where Items 1 through 3 are not met,  $SWHF = 1.0$ .

**TABLE C407.5.1(2) TABLE C407.4.1(2)**  
**HVAC SYSTEMS MAP**

CONDENSER COOLING SOURCE <sup>a</sup>	HEATING SYSTEM CLASSIFICATION <sup>b</sup>	STANDARD REFERENCE DESIGN HVC SYSTEM TYPE <sup>c</sup>		
		Single-zone Residential System	Single-zone Nonresidential System	All Other
Water/ground	Electric resistance	System 5	System 5	System 1
	Heat pump	System 6	System 6	System 6
	Fossil fuel	System 7	System 7	System 2
Air/none	Electric resistance	System 8	System 9	System 3
	Heat pump	System 8	System 9	System 3
	Fossil fuel	System 10	System 11	System 4

- Select “water/ground” where the proposed design system condenser is water or evaporatively cooled; select “air/none” where the condenser is air cooled. Closed-circuit dry coolers shall be considered to be air cooled. Systems utilizing district cooling shall be treated as if the condenser water type were “water.” Where mechanical cooling is not specified or the mechanical cooling system in the proposed design does not require heat rejection, the system shall be treated as if the condenser water type were “Air.” For proposed designs with ground-source or groundwater-source heat pumps, the standard reference design HVAC system shall be water-source heat pump (System 6).
- Select the path that corresponds to the proposed design heat source: electric resistance, heat pump (including air source and water source), or fuel fired. Systems utilizing district heating (steam or hot water) and systems without heating capability shall be treated as if the heating system type were “fossil fuel.” For systems with mixed fuel heating sources, the system or systems that use the secondary heating source type (the one with the smallest total installed output capacity for the spaces served by the system) shall be modeled identically in the standard reference design and the primary heating source type shall be used to determine standard reference design HVAC system type.
- Select the standard reference design HVAC system category: The system under “single-zone residential system” shall be selected where the HVAC system in the proposed design is a single-zone system and serves a Group R occupancy. The system under “single-zone nonresidential system” shall be selected where the HVAC system in the proposed design is a single-zone system and serves other than residential spaces Group R occupancy. The system under “all other” shall be selected for all other cases.

**Table C407.5.1(3) TABLE C407.4.1(3)**

**SPECIFICATIONS FOR THE STANDARD REFERENCE DESIGN HVAC SYSTEM DESCRIPTIONS**

SYSTEM NO.	SYSTEM TYPE	FAN CONTROL	COOLING TYPE	HEATING TYPE
1	Variable air volume with parallel fan-powered boxes <sup>a</sup>	VAV <sup>d</sup>	Chilled water <sup>e</sup>	Electric resistance
2	Variable air volume with reheat <sup>b</sup>	VAV <sup>d</sup>	Chilled water <sup>e</sup>	Hot water fossil fuel boiler <sup>f</sup>
3	Packaged variable air volume with parallel fan-powered boxes <sup>a</sup>	VAV <sup>d</sup>	Direct expansion <sup>c</sup>	Electric resistance
4	Packaged variable air volume with reheat <sup>b</sup>	VAV <sup>d</sup>	Direct expansion <sup>c</sup>	Hot water fossil fuel boiler <sup>f</sup>
5	Two-pipe fan coil	Constant volume <sup>i</sup>	Chilled water <sup>e</sup>	Electric resistance
6	Water-source heat pump	Constant volume <sup>i</sup>	Direct expansion <sup>c</sup>	Electric heat pump and boiler <sup>g</sup>
7	Four-pipe fan coil	Constant volume <sup>i</sup>	Chilled water <sup>e</sup>	Hot water fossil fuel boiler <sup>f</sup>
8	Packaged terminal heat pump	Constant volume <sup>i</sup>	Direct expansion <sup>c</sup>	Electric heat pump <sup>h</sup>
9	Packaged rooftop heat pump	Constant volume <sup>i</sup>	Direct expansion <sup>c</sup>	Electric heat pump <sup>h</sup>
10	Packaged terminal air conditioner	Constant volume <sup>i</sup>	Direct expansion	Hot water fossil fuel boiler <sup>f</sup>
11	Packaged rooftop air conditioner	Constant volume <sup>i</sup>	Direct expansion	Fossil fuel furnace

For SI: 1 foot = 304.8 mm, 1 cfm = 0.4719 L/s, 1 Btu/h = 0.293/W, °C = [(°F) – 32]/1.8.

- a. **VAV with parallel boxes:** Fans in parallel VAV fan-powered boxes shall be sized for 50 percent of the peak design flow rate and shall be modeled with 0.35 W/cfm fan power. Minimum volume setpoints for fan-powered boxes shall be equal to the minimum rate for the space required for ventilation consistent with Section C403.6.1, Item 3. Supply air temperature setpoint shall be constant at the design condition.
- b. **VAV with reheat:** Minimum volume setpoints for VAV reheat boxes shall be 0.4 cfm/ft<sup>2</sup> of floor area. Supply air temperature shall be reset based on zone demand from the design temperature difference to a 10°F temperature difference under minimum load conditions. Design airflow rates shall be sized for the reset supply air temperature; i.e., a 10°F temperature difference.
- c. **Direct expansion:** The fuel type for the cooling system shall match that of the cooling system in the proposed design.
- d. **VAV:** Where the proposed design system has a supply, return or relief fan motor 25 hp or larger, the corresponding fan in the VAV system of the standard reference design shall be modeled assuming a variable-speed drive. For smaller fans, a forward-curved centrifugal fan with inlet vanes shall be modeled. Where the proposed design's system has a direct digital control system at the zone level, static pressure setpoint reset based on zone requirements in accordance with Section C403.8.6 shall be modeled.
- e. **Chilled water:** For systems using purchased chilled water, the chillers are not explicitly modeled and chilled water costs shall be based as determined in Sections C407.2 and C407.4.2. Otherwise, the standard reference design's chiller plant shall be modeled with chillers having the number as indicated in Table C407.4.1(4) as a function of standard reference building chiller plant load and type as indicated in Table C407.4.1(5) as a function of individual chiller load. Where chiller fuel source is mixed, the system in the standard reference design shall have chillers with the same fuel types and with capacities having the same proportional capacity as the proposed design's chillers for each fuel type. Chilled water supply temperature shall be modeled at 44°F design supply temperature and 56°F return temperature. Piping losses shall not be modeled in either building model. Chilled water supply water temperature shall be reset in accordance with Section C403.4.4. Pump system power for each pumping system shall be the same as the proposed design; where the proposed design has no chilled water pumps, the standard reference design pump power shall be 22 W/gpm (equal to a pump operating against a 75-foot head, 65-percent combined impeller and motor efficiency). The chilled water system shall be modeled as primary-only variable flow with flow maintained at the design rate through each chiller using a bypass. Chilled water pumps shall be modeled as riding the pump curve or with variable-speed drives where required in Section C403.4.4. The heat rejection device shall be an axial fan cooling tower with two-speed fans where required in Section C403.10. Condenser water design supply temperature shall be 85°F or 10°F approach to design wet-bulb temperature, whichever is lower, with a design temperature rise of 10°F. The tower shall be controlled to maintain a 70°F leaving water temperature where weather permits, floating up to leaving water temperature at design conditions. Pump system power for each pumping system shall be the same as the proposed design; where the proposed design has no condenser water pumps, the standard reference design pump power shall be 19 W/gpm (equal to a pump operating against a 60-foot head, 60-percent combined impeller and motor efficiency). Each chiller shall be modeled with separate condenser water and chilled water pumps interlocked to operate with the associated chiller.
- f. **Fossil fuel boiler:** For systems using purchased hot water or steam, the boilers are not explicitly modeled and hot water or steam costs shall be based on actual utility rates. Otherwise, the boiler plant shall use the same fuel as the proposed design and shall be natural draft. The standard reference design boiler plant shall be modeled with a single boiler where the standard reference design plant load is 600,000 Btu/h and less and with two equally sized boilers for plant capacities exceeding 600,000 Btu/h. Boilers shall be staged as required by the load. Hot water supply temperature shall be modeled at 180°F design supply temperature and 130°F return temperature. Piping losses shall not be modeled in either building model. Hot water supply water temperature shall be reset in accordance with Section C403.4.4. Pump system power for each pumping system shall be the same as the proposed design; where the proposed design has no hot water pumps, the standard reference design pump power shall be 19 W/gpm (equal to a pump operating against a 60-foot head, 60-percent combined impeller and motor efficiency). The hot water system shall be modeled as primary only with continuous variable flow. Hot water pumps shall be modeled as riding the pump curve or with variable speed drives where required by Section C403.4.4.

**TABLE C407.5.1(3) TABLE C407.4.1(3) - continued**  
**SPECIFICATIONS FOR THE STANDARD REFERENCE DESIGN HVAC SYSTEM DESCRIPTIONS**

- g. **Electric heat pump and boiler:** Water-source heat pumps shall be connected to a common heat pump water loop controlled to maintain temperatures between 60°F and 90°F. Heat rejection from the loop shall be provided by an axial fan closed-circuit evaporative fluid cooler with two-speed fans where required in Section C403.8.6. Heat addition to the loop shall be provided by a boiler that uses the same fuel as the proposed design and shall be natural draft. Where no boilers exist in the proposed design, the standard reference building boilers shall be fossil fuel. The standard reference design boiler plant shall be modeled with a single boiler where the standard reference design plant load is 600,000 Btu/h or less and with two equally sized boilers for plant capacities exceeding 600,000 Btu/h. Boilers shall be staged as required by the load. Piping losses shall not be modeled in either building model. Pump system power shall be the same as the proposed design; where the proposed design has no pumps, the standard reference design pump power shall be 22 W/gpm, which is equal to a pump operating against a 75-foot head, with a 65-percent combined impeller and motor efficiency. Loop flow shall be variable with flow shutoff at each heat pump when its compressor cycles off as required by Section C403.4.4. Loop pumps shall be modeled as riding the pump curve or with variable speed drives where required by Section C403.10.
- h. **Electric heat pump:** Electric air-source heat pumps shall be modeled with electric auxiliary heat. The system shall be controlled with a multistage space thermostat and an outdoor air thermostat wired to energize auxiliary heat only on the last thermostat stage and when outdoor air temperature is less than 40°F.
- i. **Constant volume:** Fans shall be controlled in the same manner as in the proposed design; i.e., fan operation whenever the space is occupied or fan operation cycled on calls for heating and cooling. Where the fan is modeled as cycling and the fan energy is included in the energy efficiency rating of the equipment, fan energy shall not be modeled explicitly.

**Table C407.5.1(4) TABLE C407.4.1(4)**

**NUMBER OF CHILLERS**

TOTAL CHILLER PLANT CAPACITY	NUMBER OF CHILLERS
≤ 300 tons	1
> 300 tons, < 600 tons	2, sized equally
≥ 600 tons	2 minimum, with chillers added so that all are sized equally and none is larger than 800 tons

For SI: 1 ton = 3517 W.

**Table C407.5.1(5) TABLE C407.4.1(5)**  
**WATER CHILLER TYPES**

INDIVIDUAL CHILLER PLANT CAPACITY	ELECTRIC CHILLER TYPE	FOSSIL FUEL CHILLER TYPE
≤ 100 tons	Reciprocating	Single-effect absorption, direct fired
> 100 tons, < 300 tons	Screw	Double-effect absorption, direct fired
≥ 300 tons	Centrifugal	Double-effect absorption, direct fired

For SI: 1 ton = 3517 W.

**C407.6 C407.5 Calculation software tools.** Calculation procedures used to comply with this section shall be software tools capable of calculating the annual energy consumption of all building elements that differ between the *standard reference design* and the *proposed design* and shall include the following capabilities.

1. Building operation for a full calendar year (8,760 hours).
2. Climate data for a full calendar year (8,760 hours) and shall reflect *approved* coincident hourly data for temperature, solar radiation, humidity and wind speed for the building location.
3. Ten or more thermal zones.
4. Thermal mass effects.
5. Hourly variations in occupancy, illumination, receptacle loads, thermostat settings, mechanical ventilation, HVAC equipment availability, service hot water usage and any process loads.
6. Part-load performance curves for mechanical equipment.
7. Capacity and efficiency correction curves for mechanical heating and cooling equipment.
8. Printed *code official* inspection checklist listing each of the *proposed design* component characteristics from Table C407.4.1(1) determined by the analysis to provide compliance, along with their respective performance ratings, including but not limited to *R*-value, *U*-factor, SHGC, HSPF, AFUE, SEER and EF.

**C407.6.1 C407.5.1 Specific approval.** Performance analysis tools complying with the applicable subsections of Section C407 and tested according to ASHRAE Standard 140 shall be permitted to be *approved*. Tools are permitted to be *approved* based on meeting a specified threshold for a jurisdiction. The *code official* shall be permitted to approve tools for a specified application or limited scope.

**C407.6.2 C407.5.2 Input values.** Where calculations require input values not specified by Sections C402, C403, C404 and C405, those input values shall be taken from an *approved* source.

**C407.6.3 C407.5.3 Exceptional calculation methods.** Where the simulation program does not model a design, material or device of the *proposed design*, an exceptional calculation method shall be used where approved by the *code official*. Where there are multiple designs, materials or devices that the simulation program does not model, each shall be calculated separately and exceptional savings determined for each. The total exceptional savings shall not constitute more than half of the difference between the baseline building performance and the proposed building performance. Applications for approval of an exceptional method shall include all of the following:

1. Step-by-step documentation of the exceptional calculation method performed, detailed enough to reproduce the results.
2. Copies of all spreadsheets used to perform the calculations.

3. A sensitivity analysis of energy consumption where each of the input parameters is varied from half to double the value assumed.
4. The calculations shall be performed on a time step basis consistent with the simulation program used.
5. The performance rating calculated with and without the exceptional calculation method.

## SECTION C408 MAINTENANCE INFORMATION AND SYSTEM COMMISSIONING

**~~C408.1 General.~~** ~~This section covers the commissioning of the building mechanical systems in Section C403, service water heating systems in Section C404 and electrical power and lighting systems in Section C405. Buildings less than or equal to 10,000 square feet (929 m<sup>2</sup>) of conditioned floor area are exempt from commissioning requirements. Prior to the issuance of Certificate of Occupancy, a *registered design professional* shall provide a statement of system commissioning to the code official and facility owner in accordance with the provisions of this section (see Appendix C1). Items identified as deferred tests, including tests that cannot be performed because of climatic conditions, or other noted deficiencies associated with commissioning in Appendix C1 shall not prevent a certificate of occupancy from being issued.~~

**~~Exception:~~** ~~The mechanical, electrical or plumbing contractor will be allowed to prepare the statement of system commissioning when a building permit is issued for a project without the seal of a *registered design professional* as allowed by an exemption under *North Carolina Administrative Code and Policies, Section 204.3.5.*~~

**C408.1 General.** This section covers the provision of maintenance information and the commissioning of, and the functional testing requirements for, building systems.

**C408.1.1 Building operations and maintenance information.** The building operations and maintenance documents shall be provided to the owner and shall consist of manufacturers' information, specifications and recommendations; programming procedures and data points; narratives; and other means of illustrating to the owner how the building, equipment and systems are intended to be installed, maintained and operated. Required regular maintenance actions for equipment and systems shall be clearly stated on a readily visible label. The label shall include the title or publication number for the operation and maintenance manual for that particular model and type of product.

**~~C408.2 Mechanical systems and service water heating systems commissioning and completion requirements.~~** ~~*Construction document notes shall clearly indicate provisions for commissioning and completion requirements in accordance with this section and are permitted to refer to specifications for further requirements. Copies of all documentation shall be given to the owner or owner's authorized agent in accordance with Section C408.2.5.*~~

**~~Exceptions:~~** ~~The following systems are exempt:~~

- ~~1. Deleted.~~
- ~~2. Systems included in Section C403.3 that serve individual dwelling units and sleeping units.~~

**C408.2 Mechanical systems and service water-heating systems commissioning and completion requirements.** Prior to the final mechanical and plumbing inspections, the *registered design professional or approved agency* shall provide evidence of mechanical systems *commissioning* and completion in accordance with the provisions of this section.

*Construction document notes shall clearly indicate provisions for commissioning and completion requirements in accordance with this section and are permitted to refer to specifications for further requirements. Copies of all documentation shall be given to the owner or owner's authorized agent and made available to the code official upon request in accordance with Section C408.2.5.*

**Exceptions:** The following systems are exempt:

1. Mechanical systems and service water-heating systems in buildings where the total mechanical equipment capacity is less than 480,000 Btu/h (140.7 kW) cooling capacity and 600,000 Btu/h (175.8 kW) combined service water-heating and space-heating capacity.

2. Systems included in Section C403.5 that serve individual dwelling units and sleeping units.

**C408.2.1 Commissioning plan.** A *commissioning plan* shall be developed by a North Carolina registered design professional or approved agency and shall include the following items:

1. A narrative description of the activities that will be accomplished during each phase of *commissioning*, including the personnel intended to accomplish each of the activities.
2. A listing of the specific equipment, appliances or systems to be tested and a description of the tests to be performed.
3. Functions to be tested including, but not limited to, calibrations and economizer controls.
4. Conditions under which the test will be performed. Testing shall affirm winter and summer design conditions and full outside air conditions.
5. Measurable criteria for performance.

**C408.2.2 Systems adjusting and balancing.** HVAC systems shall be balanced in accordance with generally accepted engineering standards. Air and water flow rates shall be measured and adjusted to deliver final flow rates within the tolerances provided in the product specifications. Test and balance activities shall include air system and hydronic system balancing.

**C408.2.2.1 Air systems balancing.** Each supply air outlet and *zone* terminal device shall be equipped with means for air balancing in accordance with the requirements of Chapter 6 of the *International Mechanical Code*. Discharge dampers used for air-system balancing are prohibited on constant-volume fans and variable volume fans with motors 10 hp (18.6 kW) and larger. Air systems shall be balanced in a manner to first minimize throttling losses then, for fans with system power of greater than 1 hp (0.746 kW), fan speed shall be adjusted to meet design flow conditions.

**Exception:** Fans with fan motors of 1 hp (0.74 kW) or less are not required to be provided with a means for air balancing.

**C408.2.2.2 Hydronic systems balancing.** Individual hydronic heating and cooling coils shall be equipped with means for balancing and measuring flow. Hydronic systems shall be proportionately balanced in a manner to first minimize throttling losses, then the pump impeller shall be trimmed or pump speed shall be adjusted to meet design flow conditions. Each hydronic system shall have either the capability to measure pressure across the pump, or test ports at each side of each pump.

**Exception:** The following equipment is not required to be equipped with a means for balancing or measuring flow:

1. Pumps with pump motors of 5 hp (3.7 kW) or less.
2. Where throttling results in not greater than 5 percent of the nameplate horsepower draw above that required if the impeller were trimmed.

**C408.2.3 Functional performance testing.** Functional performance testing specified in Sections C408.2.3.1 through C408.2.3.3 shall be conducted.

**C408.2.3.1 Equipment.** Equipment functional performance testing shall demonstrate the installation and operation of components, systems and system-to-system interfacing relationships in accordance with approved plans and specifications such that operation, function and maintenance serviceability for each of the commissioned systems are confirmed. Testing shall include all modes and *sequence of operation*, including under full-load, part-load and the following emergency conditions:

1. All modes as described in the *sequence of operation*.
2. Redundant or *automatic* back-up mode.
3. Performance of alarms.
4. Mode of operation upon a loss of power and restoration of power.

**Exception:** Unitary or packaged HVAC equipment listed in ~~Tables C403.2.3(1) through C403.2.3(3)~~ the tables in Section C403.3.2 that do not require supply air economizers.

**C408.2.3.2 Controls.** HVAC and service water-heating control systems shall be tested to document that control devices, components, equipment and systems are calibrated and adjusted and operate in accordance with approved plans and specifications. Sequences of operation shall be functionally tested to document they operate in accordance with *approved* plans and specifications.

**C408.2.3.3 Economizers.** Air economizers shall undergo a functional test to determine that they operate in accordance with manufacturer’s specifications, Construction documents.

~~**C408.2.4 Preliminary commissioning report.** Deleted.~~

**C408.2.4 Preliminary commissioning report.** A preliminary report of *commissioning* test procedures and results shall be completed and certified by the *registered design professional* or *approved agency* and provided to the building owner or owner’s authorized agent. The report shall be organized with mechanical and service hot water findings in separate sections to allow independent review. The report shall be identified as “Preliminary Commissioning Report,” shall include the completed Commissioning Compliance Checklist, Figure C408.2.4, and shall identify:

1. Itemization of deficiencies found during testing required by this section that have not been corrected at the time of report preparation.
2. Deferred tests that cannot be performed at the time of report preparation because of climatic conditions.
3. Climatic conditions required for performance of the deferred tests.
4. Results of functional performance tests.
5. Functional performance test procedures used during the commissioning process, including measurable criteria for test acceptance.

Project Information: \_\_\_\_\_ Project Name: \_\_\_\_\_

Project Address: \_\_\_\_\_

Commissioning Authority: \_\_\_\_\_

Commissioning Plan (Section C408.2.1)

Commissioning Plan was used during construction and includes all items required by Section C408.2.1

Systems Adjusting and Balancing has been completed.

HVAC Equipment Functional Testing has been executed. If applicable, deferred and follow-up testing is scheduled to be provided on: \_\_\_\_\_

HVAC Controls Functional Testing has been executed. If applicable, deferred and follow-up testing is scheduled to be provided on: \_\_\_\_\_

Economizer Functional Testing has been executed. If applicable, deferred and follow-up testing is scheduled to be provided on: \_\_\_\_\_

Lighting Controls Functional Testing has been executed. If applicable, deferred and follow-up testing is scheduled to be provided on: \_\_\_\_\_

Service Water Heating System Functional Testing has been executed. If applicable, deferred and follow-up testing is scheduled to be provided on: \_\_\_\_\_

Manual, record documents and training have been completed or scheduled

Preliminary Commissioning Report submitted to owner and includes all items required by Section C408.2.4

I hereby certify that the commissioning provider has provided me with evidence of mechanical, service water heating and lighting systems commissioning in accordance with the 2021 IECC.

Signature of Building Owner or Owner’s Representative \_\_\_\_\_ Date \_\_\_\_\_

FIGURE C408.2.4 COMMISSIONING COMPLIANCE CHECKLIST

**C408.2.4.1 Acceptance of report.** Buildings, or portions thereof, shall not be considered as acceptable for a final inspection pursuant to Section C105.2.6 until the *code official* has received the Preliminary Commissioning Report from the building owner or owner’s authorized agent.

**C408.2.4.2 Copy of report.** The *code official* shall be permitted to require that a copy of the Preliminary Commissioning Report be made available for review by the *code official*.

**C408.2.5 Documentation requirements.** The *construction documents* shall specify that the documents described in this section be provided to the building owner or owner’s authorized agent within 90 days of the date of receipt of the *certificate of occupancy*.

**C408.2.5.1 System test and balance balancing report.** A written report describing the activities and measurements completed in accordance with Section C408.2.2.

~~**C408.2.5.4 Final commissioning report.** Deleted.~~

**C408.2.5.2 Final commissioning report.** A report of test procedures and results identified as “Final Commissioning Report” shall be delivered to the building owner or owner’s authorized agent. The report shall be organized with mechanical

system and service hot water system findings in separate sections to allow independent review. The report shall include the following:

1. Results of functional performance tests.
2. Disposition of deficiencies found during testing, including details of corrective measures used or proposed.
3. Functional performance test procedures used during the commissioning process including measurable criteria for test acceptance, provided herein for repeatability.

Exception: Deferred tests that cannot be performed at the time of report preparation due to climatic conditions.

~~**C408.3 Lighting system functional testing.** Functional performance testing specified in Sections C408.3.1 and C408.3.1.1 through C408.3.1.3 shall be conducted. Manuals shall be provided in accordance with Section C408.3.2.~~

**C408.3 Functional testing of lighting controls.** Automatic lighting controls required by this code shall comply with this section.

~~**C408.3.1 Functional testing.** The lighting control systems shall be tested to ensure that control hardware and software are calibrated, adjusted, programmed and in proper working condition in accordance with the *construction documents* and manufacturer's instructions. Functional testing shall be in accordance with Sections C408.3.1.1 and C408.3.1.2 for the applicable control type.~~

**C408.3.1 Functional testing.** The lighting control systems shall be tested to ensure that control hardware and software Prior to passing final inspection, the *registered design professional* or *approved agency* shall provide evidence that the lighting control systems have been tested to ensure that control hardware and software are calibrated, adjusted, programmed and in proper working condition in accordance with the *construction documents* and manufacturer's instructions. Functional testing shall be in accordance with Sections C408.3.1.1 and C408.3.1.2 through C408.3.1.3 for the applicable control type.

**C408.3.1.1 Occupant sensor controls.** Where *occupant sensor controls* are provided, the following procedures shall be performed:

1. Certify that the *occupant sensor* has been located and aimed in accordance with manufacturer recommendations.
2. For projects with seven or fewer *occupant sensors*, each sensor shall be tested.
3. For projects with more than seven *occupant sensors*, testing shall be done for each unique combination of sensor type and space geometry. Where multiples of each unique combination of sensor type and space geometry are provided, not less than 10 percent and in no case fewer than one, of each combination shall be tested unless the *code official* or design professional requires a higher percentage to be tested. Where 30 percent or more of the tested controls fail, all remaining identical combinations shall be tested.

For *occupant sensor controls* to be tested, verify the following:

- 3.1. Where *occupant sensor controls* include status indicators, verify correct operation.
- 3.2. The controlled lights turn off or down to the permitted level within the required time.
- 3.3. For auto-on *occupant sensor controls*, the lights turn on to the permitted level when an occupant enters the space.
- 3.4. For manual-on *occupant sensor controls*, the lights turn on only when manually activated.
- 3.5. The lights are not incorrectly turned on by movement in adjacent areas or by HVAC operation.

**C408.3.1.2 Time-switch controls.** Where *time-switch controls* are provided, the following procedures shall be performed:

1. Confirm that the *time-switch control* is programmed with accurate weekday, weekend and holiday schedules.
2. Provide documentation to the owner of *time-switch controls* programming including weekday, weekend, holiday schedules, and set-up and preference program settings.
3. Verify the correct time and date in the time switch.
4. Verify that any battery back-up is installed and energized.
5. Verify that the override time limit is set to not more than 2 hours.
6. Simulate occupied condition. Verify and document the following:



- 6.1. All lights can be turned on and off by their respective area control switch.
- 6.2. The switch only operates lighting in the enclosed space in which the switch is located.
7. Simulate unoccupied condition. Verify and document the following:
  - 7.1. Nonexempt lighting turns off.
  - 7.2. Manual override switch allows only the lights in the enclosed space where the override switch is located to turn on or remain on until the next scheduled shutoff occurs.
8. Additional testing as specified by the *registered design professional*.

**C408.3.1.3 Daylight responsive controls.** Where *daylight responsive controls* are provided, the following shall be verified:

1. Control devices have been properly located, field calibrated and set for accurate setpoints and threshold light levels.
2. Daylight controlled lighting loads adjust to light level setpoints in response to available daylight.
3. ~~The locations of calibration adjustment equipment are readily accessible only to authorized personnel.~~
3. The calibration adjustment equipment is located for *ready access* only by authorized personnel.

~~**C408.4 Documentation requirements.** Prior to the issuance of Certificate of Occupancy, a *registered design professional* shall provide a statement of system commissioning to the code official and facility owner in accordance with the provisions of this section (see Appendix C1). Items identified as deferred tests, including tests that cannot be performed because of climatic conditions, or other noted deficiencies associated with commissioning in Appendix C1 shall not prevent a certificate of occupancy from being issued.~~

~~**Exception:** The mechanical, electrical or plumbing contractor will be allowed to prepare the statement of system commissioning when a building permit is issued for a project without the seal of a licensed design professional as allowed by an exemption under *North Carolina State Building Administrative Code and Policies*, Section 204.3.5.~~

**C408.3.2 Documentation requirements.** The *construction documents* shall specify that the documents described in this section be provided to the building owner or owner's authorized agent within 90 days of the date of receipt of the *certificate of occupancy*.

**C408.3.2.1 Drawings.** Construction documents shall include the location and catalogue number of each piece of equipment.

~~**C408.3.2 Manuals.** An operating and maintenance manual shall be provided and include all of the following:~~

1. ~~Submittal data indicating all selected options for each piece of lighting equipment and lighting controls.~~
2. ~~Operation and maintenance manuals for each piece of lighting equipment. Required routine maintenance actions, cleaning and recommended relamping shall be clearly identified.~~
3. ~~A schedule for inspecting and recalibrating all lighting controls.~~
4. ~~A narrative of how each system is intended to operate, including recommended set points.~~

**C408.3.2.2 Manuals.** An operating and maintenance manual shall be provided and include the following:

1. Name and address of not less than one service agency for installed equipment.
2. A narrative of how each system is intended to operate, including recommended setpoints.
3. Submittal data indicating all selected options for each piece of lighting equipment and lighting controls.
4. Operation and maintenance manuals for each piece of lighting equipment. Required routine maintenance actions, cleaning and recommended relamping shall be clearly identified.
5. A schedule for inspecting and recalibrating all lighting controls.

**C408.3.2.3 Report.** A report of test results shall be provided and include the following:

1. Results of functional performance tests.

2. Disposition of deficiencies found during testing, including details of corrective measures used or proposed.

# CHAPTER 5 [CE] EXISTING BUILDINGS

## SECTION C501 GENERAL

**C501.1 Scope.** The provisions of this chapter shall control the *alteration, repair, addition* and *change of occupancy* of existing buildings and structures.

~~**C501.1.1 Additions, alterations, or repairs: General.** Additions, alterations, or repairs to an existing building, building system or portion thereof shall comply with Section C502, C503 or C504. Unaltered portions of the existing building or building supply system shall not be required to comply with this code.~~

**C501.1.1 Existing buildings.** Except as specified in this chapter, this code shall not be used to require the removal, *alteration* or abandonment of, nor prevent the continued use and maintenance of, an existing *building* or *building system* lawfully in existence at the time of adoption of this code.

**\*\* C501.4 C501.2 Compliance.** *Additions, alterations, repairs*, and changes of occupancy to, or relocation of, existing *buildings* and structures shall comply with Sections C502, C503, C504 and C505 of this code, as applicable, and with the provisions for *alterations, repairs, additions* and changes of occupancy or relocation, respectively, in the *International Building Code, International Existing Building Code, International Fire Code, International Fuel Gas Code, International Mechanical Code, International Plumbing Code, North Carolina Existing Building Code, International Property Maintenance Code, International Private Sewage Disposal Code* and NFPA 70. Changes where unconditioned space is changed to conditioned space shall comply with Section C502.

**Exception:** *Additions, alterations, repairs* or changes of occupancy complying with ANSI/ASHRAE/IESNA 90.1.

~~**C501.3 Maintenance.** Deleted.~~

**C501.3 Maintenance.** *Buildings* and structures, and parts thereof, shall be maintained in a safe and sanitary condition. Devices and systems required by this code shall be maintained in conformance to the code edition under which they were installed. The owner or the owner's authorized agent shall be responsible for the maintenance of buildings and structures. The requirements of this chapter shall not provide the basis for removal or abrogation of energy conservation, fire protection and safety systems and devices in existing structures.

**C501.5 C501.4 New and replacement materials.** Except as otherwise required or permitted by this code, materials permitted by the applicable code for new construction shall be used. Like materials shall be permitted for *repairs*, provided that hazards to life, health or property are not created. Hazardous materials shall not be used where the code for new construction would not allow use of these materials in buildings of similar occupancy, purpose and location.

**C501.6 C501.5 Historic buildings.** Provisions of this code relating to the construction, *repair, alteration*, restoration and movement of structures, and *change of occupancy* shall not be mandatory for *historic buildings* provided that a report has been submitted to the *code official* and signed by a *registered design professional*, or a representative of the State Historic Preservation Office or the historic preservation authority having jurisdiction, demonstrating that compliance with that provision would threaten, degrade or destroy the historic form, fabric or function of the *building*.

## SECTION C502 ADDITIONS

**C502.1 General.** *Additions* to an existing *building, building system* or portion thereof shall conform to the provisions of this code as those provisions relate to new construction without requiring the unaltered portion of the existing *building* or *building system* to comply with this code. *Additions* shall not create an unsafe or hazardous condition or overload existing building systems. An *addition* shall be deemed to comply with this code if the *addition* alone complies or if the existing building and *addition* comply with this code as a single building. ~~*Additions shall comply with Section C502.2.*~~

**C502.2 Change in space conditioning.** Any nonconditioned or low-energy space that is altered to become *conditioned space* shall be required to comply with Section C502.

**Exceptions:**

1. Where the component performance alternative in Section C402.1.5 is used to comply with this section, the proposed UA shall be not greater than 110 percent of the target UA.
2. Where the total building performance option in Section C407 is used to comply with this section, the annual energy cost of the proposed design shall be not greater than 110 percent of the annual energy cost otherwise permitted by Section C407.2.

**C502.2 Prescriptive compliance. C502.3 Compliance.** Additions shall comply with Sections C502.3.1 through C502.3.6.2.

**C502.2.1 Vertical fenestration.** New *vertical fenestration* area that results in a total building *fenestration* area less than or equal to that specified in Section C402.4.1 shall comply with Section C402.4. Additions with *vertical fenestration* that result in a total building *fenestration* area greater than Section C402.4.1 or additions that exceed the *fenestration* area greater than Section C402.4.1 shall comply with Section C407.

**C502.3.1 Vertical fenestration area.** Additions shall comply with the following:

1. Where an addition has a new vertical fenestration area that results in a total building fenestration area less than or equal to that permitted by Section C402.4.1, the addition shall comply with Section C402.1.5, C402.4.3 or C407.
2. Where an addition with vertical fenestration that results in a total building fenestration area greater than Section C402.4.1 or an addition that exceeds the fenestration area greater than that permitted by Section C402.4.1, the fenestration shall comply with Section C402.4.1.1 for the addition only.
3. Where an addition has vertical fenestration that results in a total building vertical fenestration area exceeding that permitted by Section C402.4.1.1, the addition shall comply with Section C402.1.5 or C407.

**C502.2.2 Skylight area.** New *skylight* area that results in a total building *fenestration* area less than or equal to that specified in Section C402.4.1 shall comply with Section C402.4. Additions with *skylight* area that result in a total building *skylight* area greater than C402.4.1 or additions that exceed the *skylight* area shall comply with Section C407.

**C502.3.2 Skylight area.** Skylights shall comply with the following:

1. Where an addition has new skylight area that results in a total building fenestration area less than or equal to that permitted by Section C402.4.1, the addition shall comply with Section C402.1.5 or C407.
2. Where an addition has new skylight area that results in a total building skylight area greater than permitted by Section C402.4.1 or where additions have skylight area greater than that permitted by Section C402.4.1, the skylight area shall comply with Section C402.4.1.2 for the addition only.
3. Where an addition has skylight area that results in a total building skylight area exceeding that permitted by Section C402.4.1.2, the addition shall comply with Section C402.1.5 or C407.

**C502.2.3 C502.3.3 Building mechanical systems.** New mechanical systems and equipment that are part of the *addition* and serve the building heating, cooling and ventilation needs shall comply with Sections C403 and C408.

**C502.2.4 C502.3.4 Service water-heating systems.** New service water-heating equipment, controls and service water-heating piping shall comply with Section C404.

**C502.2.5 C502.3.5 Pools and inground permanently installed spas.** New pools and inground permanently installed spas shall comply with Section C404.9.

**C502.2.6 C502.3.6 Lighting power and systems.** New lighting systems that are installed as part of the addition shall comply with Sections C405 and C408.

**C502.2.6.1 C502.3.6.1 Interior lighting power.** The total interior lighting power for the *addition* shall comply with Section C405.4.2 C405.3.2 for the *addition* alone, or the existing building and the *addition* shall comply as a single building.

~~C502.2.6.2 C502.3.6.2 Exterior lighting power.~~ The total exterior lighting power for the *addition* shall comply with Section ~~C405.5.1 C405.5.2~~ for the *addition* alone, or the existing building and the *addition* shall comply as a single building.

~~C502.2.7 Building envelope.~~ New building envelope assemblies that are part of the *addition* shall comply with Sections ~~C402.1 through C402.5.~~

## SECTION C503 ALTERATIONS

**C503.1 General.** ~~Alterations to any building or structure shall conform to the provisions of this code shall comply with the requirements of Section C503.~~ *Alterations* shall be such that the existing *building* or structure is not less conforming to the provisions of this code than the existing *building* or structure was prior to the *alteration*. *Alterations* to an existing *building*, *building* system or portion thereof shall conform to the provisions of this code as those provisions relate to new construction without requiring the unaltered portions of the existing *building* or *building* system to comply with this code. *Alterations* shall not create an unsafe or hazardous condition or overload existing *building* systems.

### Exceptions:

~~1. Alterations complying with ANSI/ASHRAE/IESNA 90.1.~~

~~2. The following alterations to conditioned spaces need not comply with the requirements for new construction:~~

~~a. Storm windows installed over existing fenestration.~~

~~b. Surface applied window film installed on existing single pane fenestration assemblies reducing solar heat gain.~~

~~c. Existing ceiling, wall or floor cavities exposed during construction, provided that these cavities are filled with insulation. Roof systems requiring air space for ventilation shall retain the ventilation space required.~~

~~d. Construction where the existing roof, wall or floor cavity is not exposed.~~

~~e. Roof recover and roof replacement such that the existing building or structure is no less conforming to the provisions of this code than the existing building or structure was prior to the alteration.~~

~~f. Air barriers shall not be required for roof recover and roof replacement where the alterations or renovations to the building do not include alterations, renovations or repairs to the remainder of the building envelope.~~

~~g. Alterations that replace less than 50 percent of the luminaires in a space, provided that such alterations do not increase the installed interior lighting power.~~

~~h. Replacement of existing doors that separate conditioned space from the exterior shall not require the installation of a vestibule or revolving door, provided, however, that an existing vestibule that separates a conditioned space from the exterior shall not be removed.~~

**Exception:** The following alterations need not comply with the requirements for new construction, provided that the energy use of the building is not increased:

1. Storm windows installed over existing fenestration.

2. Surface-applied window film installed on existing single-pane fenestration assemblies reducing solar heat gain, provided that the code does not require the glazing or fenestration to be replaced.

3. Existing ceiling, wall or floor cavities exposed during construction, provided that these cavities are filled with insulation.

4. Construction where the existing roof, wall or floor cavity is not exposed.

5. Roof recover.

6. Air barriers shall not be required for roof recover and roof replacement where the alterations or renovations to the building do not include alterations, renovations or repairs to the remainder of the building envelope.

~~**C503.2 Change in space conditioning.** New work performed shall meet the requirements of this code. Projects changing unconditioned space to conditioned space and costing more than \$10,000 shall require 10 percent of the project cost to be used toward meeting the requirements of the *North Carolina Energy Conservation Code*. Project cost for the purpose of this section is the total project cost listed on all permits related to the work required to convert the unconditioned space to conditioned space and excludes the 10 percent added from this section. Under this section, existing building envelope elements that become a part of the building thermal envelope and are not changed are not required to be upgraded. The additional 10 percent of the project cost shall be appropriated for additional energy conservation features of choice that are addressed in the *North Carolina Energy Conservation Code*. In addition to the 10 percent project cost, any existing wall, ceiling, or floor cavities that are exposed during construction shall at a minimum be insulated to comply with the *North Carolina Energy Conservation Code* or be insulated to fill the cavity, whichever is less. Roof systems requiring air space for ventilation shall retain the ventilation space required. Projects costing less than \$10,000 are not subject to the 10 percent project cost addition provision.~~

**C503.3 C503.2 Building envelope.** New building envelope assemblies that are part of the *alteration* shall comply with Sections C402.1 through C402.5.

**Exception:** Where the existing building exceeds the fenestration area limitations of Section C402.4.1 prior to alteration, the building is exempt from Section C402.4.1 provided that there is not an increase in fenestration area.

~~**C503.3.1 Roof replacement.** Deleted.~~

**C503.3.1 C503.2.1 Roof replacement.** *Roof replacements* shall comply with Section C402.1.3, C402.1.4, C402.1.5 or C407 where the existing roof assembly is part of the *building thermal envelope* and contains insulation entirely above the roof deck. In no case shall the *R-value* of the roof insulation be reduced or the *U-factor* of the roof assembly be increased as part of the *roof replacement*.

**C503.3.2 Vertical fenestration.** The addition of *vertical fenestration* that results in a total building *fenestration* area less than or equal to that specified in Section C402.4.1 shall comply with Section C402.4. The addition of *vertical fenestration* that results in a total building *fenestration* area greater than Section C402.4.1 shall comply with Section C407.

**C503.3.2 C503.2.2 Vertical fenestration.** The addition of *vertical fenestration* that results in a total building *fenestration* area less than or equal to that specified in Section C402.4.1 shall comply with Section C402.1.5, C402.4.3 or C407. The addition of *vertical fenestration* that results in a total building *fenestration* area greater than Section C402.4.1 shall comply with Section C402.4.1.1 for the space adjacent to the new fenestration only. *Alterations* that result in a total building *vertical fenestration* area exceeding that specified in Section C402.4.1.1 shall comply with Section C402.1.5 or C407. Provided that the vertical fenestration area is not changed, using the same vertical fenestration area in the *standard reference design* as the building prior to alteration shall be an alternative to using the vertical fenestration area specified in Table C407.4.1(1).

**C503.1.1 \*\* C503.2.2.1 Application to replacement fenestration products.** Where an entire existing fenestration unit is replaced with a new fenestration product, including frame, sash and glazing, the replacement fenestration unit shall meet the applicable requirements for *U-factor* and *SHGC* in Table C402.4. Where some or all of an existing *fenestration* unit is replaced with a new *fenestration* product, including sash and glazing, the replacement *fenestration* unit shall meet the applicable requirements for *U-factor* and *SHGC* in Table C402.4.

**Exceptions Exception:**

1. An area-weighted average of the *U-factor* of replacement fenestration products being installed in the building for each fenestration product category listed in Table C402.4 shall be permitted to satisfy the *U-factor* requirements for each fenestration product category listed in Table C402.4. Individual fenestration products from different product categories listed in Table C402.4 shall not be combined in calculating the area-weighted average *U-factor*.

2. Alterations that replace less than 50 percent of entire fenestration units may be replaced with like or better fenestration units to match existing fenestration assemblies.

~~**C503.3.3 C503.2.3 Skylight area.** The addition of *New skylight area* that results in a total building *skylight area* less than or equal to that specified in Section C402.4.1 shall comply with Section C402.1.5, C402.4 or C407. The addition of *skylight area* that results in a total building *skylight area* greater than Section C402.4.1 shall comply with Section C407 C402.4.1.2 for the space adjacent to the new skylights. *Alterations* that result in a total building *skylight area* exceeding that specified in Section C402.4.1 C402.4.1.2 shall comply with Section C402.1.5 or C407. Provided that the skylight area is not changed, using the~~

same skylight area in the standard reference design as the building prior to alteration shall be an alternative to using the skylight area specified in Table C407.4.1(1).

~~C503.4~~ **C503.3 Heating and cooling systems.** New heating, cooling and duct systems that are part of the *alteration* shall comply with Sections C403 and C408.

**Exception:**

1. Not required to comply with Section C403.2.12.
2. Not required to comply with Section C403.3 where alterations to existing floors, walls, or roof assemblies are required.

~~C503.4.1 Economizers.~~ Deleted. See Section C503.4.

C503.3.1 Economizers. New cooling systems that are part of *alteration* shall comply with Section C403.5.

~~C503.5~~ **C503.4 Service hot water systems.** New service hot water systems that are part of the *alteration* shall comply with Sections C404 and C408.

~~C503.6~~ **C503.5 Lighting systems.** New lighting systems that are part of the *alteration* shall comply with Sections C405 and C408.

**Exception:** *Alterations* that replace less than ~~50~~ 10 percent of the luminaires in a space, provided that such *alterations* do not increase the installed interior lighting power.

## SECTION C504 REPAIRS

~~C504.1 General.~~ *Repair of the building systems shall not make the building less conforming than it was before the repair was undertaken. Work on nondamaged components necessary for the required repair of damaged components shall be considered part of the repair and shall not be subject to the requirements for alterations in this chapter.*

C504.1 General. *Buildings and structures, and parts thereof, shall be repaired in compliance with Section C501.3 and this section. Work on nondamaged components that is necessary for the required repair of damaged components shall be considered to be part of the repair and shall not be subject to the requirements for alterations in this chapter. Routine maintenance required by Section C501.3, ordinary repairs exempt from permit and abatement of wear due to normal service conditions shall not be subject to the requirements for repairs in this section.*

Where a building was constructed to comply with ANSI/ASHRAE/IESNA 90.1, repairs shall comply with the standard and need not comply with Sections C402, C403, C404 and C405.

~~C504.2 Materials.~~ *Portions of walls that are part of the building thermal envelope shall be insulated in accordance with this code when the repair requires the removal of either the interior or exterior wall membrane such that the wall cavity is exposed during the repair.*

~~Exception:~~ *Wall cavities containing existing insulation material.*

C504.2 Application. For the purposes of this code, the following shall be considered to be repairs:

1. Glass-only replacements in an existing sash and frame.
2. Roof repairs.
3. Air barriers shall not be required for roof repair where the repairs to the building do not include alterations, renovations or repairs to the remainder of the building envelope.
4. Replacement of existing doors that separate conditioned space from the exterior shall not require the installation of a vestibule or revolving door, provided that an existing vestibule that separates a conditioned space from the exterior shall not be removed.
5. Repairs where only the bulb, the ballast or both within the existing luminaires in a space are replaced, provided that the replacement does not increase the installed interior lighting power.

~~C504.3 Glazing.~~ *Repairs requiring the replacement of individual glass panes or sashes shall not require compliance with this code.*

**SECTION C505  
CHANGE OF OCCUPANCY OR USE**

~~**C505.1 General.** New work performed in spaces undergoing a change in occupancy shall comply with the requirements of this code. Unaltered portions of the existing building or building supply system shall not be required to comply with this code.~~

**C505.1 General.** Spaces undergoing a change in occupancy that would result in an increase in demand for either fossil fuel or electrical energy shall comply with this code. Where the use in a space changes from one use in Table C405.3.2(1) or C405.3.2(2) to another use in Table C405.3.2(1) or C405.3.2(2), the installed lighting wattage shall comply with Section C405.3. Where the space undergoing a change in occupancy or use is in a building with a fenestration area that exceeds the limitations of Section C402.4.1, the space is exempt from Section C402.4.1 provided that there is not an increase in fenestration area.

**Exceptions:**

1. Where the component performance alternative in Section C402.1.5 is used to comply with this section, the proposed UA shall not be greater than 110 percent of the target UA.
2. Where the total building performance option in Section C407 is used to comply with this section, the annual energy cost of the proposed design shall not be greater than 110 percent of the annual energy cost otherwise permitted by Section ~~C407.3.~~ C407.2.



## CHAPTER 6 [CE] REFERENCED STANDARDS

---

### AAMA

American Architectural Manufacturers Association  
1827 Walden Office Square  
Suite 550

Schaumburg, IL 60173-4268

AAMA/WDMA/CSA 101/LS.2/A ~~C440-11~~ C440-17

North American Fenestration Standard/Specifications for Windows, Doors and Unit Skylights  
Table C402.5.5

---

### AHAM

Association of Home Appliance Manufacturers  
1111 19th Street NW, Suite 402

Washington, DC 20036

~~ANSI/AHAM RAC-1—2008~~

ANSI/AHAM RAC-1—2015

Room Air Conditioners

Table C403.3.2(4)

---

### AHRI

Air-Conditioning, Heating, & Refrigeration Institute  
2111 Wilson Blvd, Suite 500

Arlington, VA22201

~~210/240—08 with Addenda 1 and 2~~

210/240—2017 and 2023

Performance Rating of Unitary Air-conditioning and Air-source Heat Pump Equipment

Table C403.3.2(1), Table C403.3.2(2)

~~310/380—04 (CSA-C744-04)~~

310/380—2017 (CSA-C744-17)

Packaged Terminal Air Conditioners and Heat Pumps

Table C403.3.2(4)

~~340/360—2007~~

340/360—2019

Performance Rating of Commercial and Industrial Unitary Air-conditioning and Heat Pump Equipment

Table C403.3.2(1), Table C403.3.2(2)

~~365(I-P)—2009~~

Commercial and Industrial Unitary Air-conditioning Condensing Units

Table C403.3.2(1)

~~390—03~~

390 (I-P)—2003

Performance Rating of Single Package Vertical Air-conditioners and Heat Pumps

182

20182024 NORTH CAROLINA ENERGY CONSERVATION CODE®

Table C403.3.2(3)

**400 (I-P)—2015**

**Performance Rating of Liquid to Liquid Heat Exchangers**

C403.3.2

**440—2008**

**Performance Rating of Room Fan Coils—with Addendum 1**

C403.12.3

**460—2005**

**Performance Rating of Remote Mechanical-draft Air-cooled Refrigerant Condensers**

Table C403.3.2(7)

**~~550/590—2011 with Addendum 1~~**

**550/590 (I-P)—2018**

**Performance Rating of Water-chilling and Heat Pump Water-heating Packages Using the Vapor Compression Cycle**

Table C403.3.2(3), Table C403.3.2(15)

**560—00**

**560—2018**

**Absorption Water Chilling and Water Heating Packages**

Table C403.3.2(3)

**~~1160(I-P)—09~~**

**910—2014**

**Performance Rating of Indoor Pool Dehumidifiers**

Table C404.2

**AHRI—continued**

**920—2015**

**Performance Rating of DX-Dedicated Outdoor Air System Units**

Table C403.3.2(12), Table C403.3.2(13)

**1160 (I-P)—2014**

**Performance Rating of Heat Pump Pool Heaters (with Addendum 1)**

Table C404.2

**1200 (I-P)—2013**

**Performance Rating of Commercial Refrigerated Display Merchandisers and Storage Cabinets**

Table C403.11.1

**1230—2014**

**Performance Rating of Variable Refrigerant Flow (VRF) Multi-split Air-Conditioning and Heat Pump Equipment (with Addendum 1)**

Table C403.3.2(9)

**1250 (I-P)—2014**

**Standard for Performance Rating in Walk-in Coolers and Freezers**

Table C403.11.2.1(3)

**1360—2017**

**Performance Rating of Computer and Data Processing Room Air Conditioners**

Table C403.3.2(10) , Table C403.3.2(16)

**ISO/AHRI/ASHRAE 13256-1 (2011)**

**ISO/AHRI/ASHRAE 13256-1 (2012)**

**Water-to-Air and Brine-to-Air Heat Pumps—Testing and Rating for Performance**

Table C403.3.2(2)

---

## **AMCA**

Air Movement and Control Association International  
30 West University Drive

Arlington Heights, IL 60004-1806

---

**208—18**

**Calculation of the Fan Energy Index**

C403.8.3

**220—08 (R2012)**

**220—19**

**Laboratory Methods of Testing Air Curtain Units for Aerodynamic Performance Rating**

C402.5.9

**230—15**

**Laboratory Methods of Testing Air Circulating Fans for Rating and Certification**

C403.9

**500D—18**

**Laboratory Methods for Testing Dampers for Rating**

C403.7.7

---

## **ANSI**

American National Standards Institute  
25 West 43rd Street, 4th Floor  
New York, NY 10036

**Z21.10.3/CSA 4.3—11**

**Z21.10.3/CSA 4.3—17**

**Gas Water Heaters, Volume III—Storage Water Heaters with Input Ratings Above 75,000 Btu per Hour, Circulating Tank and Instantaneous**

Table C404.2

**Z21.47/CSA 2.3—12**

**Z21.47/CSA 2.3—16**

**Gas-fired Central Furnaces**

Table C403.3.2(4)

**Z83.8/CSA 2.6—09**

**Z83.8/CSA 2.6—16**

Gas Unit Heaters, Gas Packaged Heaters, Gas Utility Heaters and Gas-fired Duct Furnaces  
Table C403.3.2(4)

---

**APSP**

Pool & Hot Tub Alliance (formerly the Association of Pool and Spa Professionals)  
2111 Eisenhower Avenue, Suite 580  
Alexandria, VA 22314

---

14—2019

American National Standard for Portable Electric Spa Energy Efficiency  
C404.7

---

**ASABE**

American Society of Agricultural and Biological Engineers  
2950 Niles Road  
St. Joseph, MI 49085

---

S640—2017

Quantities and Units of Electromagnetic Radiation for Plants (Photosynthetic Organisms)  
C405.4

---

**ASHRAE**

ASHRAE  
180 Technology Parkway NW  
Peachtree Corners, GA 30092

55—2017

~~Thermal Environmental Conditions for Human Occupancy~~  
~~Table C407.4.1(1)~~

90.1—2013

90.1—2019

Energy Standard for Buildings Except Low-rise Residential Buildings  
C402.1.4, C406.2

90.4—2016

Energy Standard for Data Centers  
C403.1.2, C405.2.4

~~ASHRAE~~

~~127-2007 Method of Testing for Rating Computer..... Table C403.2.3(9)~~

140—2014

Standard Method of Test for the Evaluation of Building Energy Analysis Computer Programs  
C407.5.1

146—2011

Testing for Rating Pool Heaters  
Table C404.2

~~ANSI/ASHRAE/ACCA Standard 183—(RA2007)~~

ANSI/ASHRAE/ACCA Standard 183—(RA2017)

Peak Cooling and Heating Load Calculations in Buildings, Except Low-rise Residential Buildings

C403.1.1

**ASHRAE—2020**

**HVAC Systems and Equipment Handbook—2020**

C403.1.1

**ISO/AHRI/ASHRAE 13256-1 (2012)**

**Water-to-Air and Brine-to-Air Heat Pumps—Testing and Rating for Performance**

Table C403.3.2(14)

**ISO/AHRI/ASHRAE 13256-2 (2012)**

**Water-to-Water and Brine-to-Water Heat Pumps—Testing and Rating for Performance**

Table C403.3.2(14)

---

## ASME

American Society of Mechanical Engineers  
Two Park Avenue  
New York, NY 10016-5990

**ASME A17.1—CSA B44—2013**

**ASME A17.1—2019/CSA B44—19**

**Safety Code for Elevators and Escalators**

C405.9.2

---

## ASTM

ASTM International  
100 Barr Harbor Drive, P.O. Box C700

West Conshohocken, PA 19428-2959

**C90—2016A**

**Specification for Load-bearing Concrete Masonry Units**

Table C402.1.3

**C1363—11**

**Standard Test Method for Thermal Performance of Building Materials and Envelope Assemblies by Means of a Hot Box Apparatus**

C303.1.4.1, Table C402.1.4, 402.2.7

**C1371—15**

**Standard Test Method for Determination of Emittance of Materials Near Room Temperature Using Portable Emissometers**

Table C402.3

**~~C1549—09~~**

**C1549—2016**

**Standard Test Method for Determination of Solar Reflectance Near Ambient Temperature Using a Portable Solar Reflectometer**

Table C402.3

**D1003—13**

**Standard Test Method for Haze and Luminous Transmittance of Transparent Plastics**

C402.4.2.2

**D8052/D8052M—2017**

**Standard Test Method for Quantification of Air Leakage in Low-Sloped Membrane Roof Assemblies**

C402.5.2.1.2

~~E283—2004~~

E283—2004(2012)

**Test Method for Determining the Rate of Air Leakage Through Exterior Windows, Curtain Walls and Doors Under Specified Pressure Differences Across the Specimen**

C402.5.2.1.2, Table C402.5.5, C402.5.11

E408—13

**Test Methods for Total Normal Emittance of Surfaces Using Inspection-meter Techniques**

Table C402.3

**ASTM—continued**

~~E779—10~~

E779—10(2018)

**Standard Test Method for Determining Air Leakage Rate by Fan Pressurization**

C402.5.3, C402.5.4, C406.9

~~E903—96~~

E903—2012

**Standard Test Method Solar Absorptance, Reflectance and Transmittance of Materials Using Integrating Spheres (Withdrawn 2005)**

Table C402.3

E1677—11

**Specification for Air Barrier (AB) Material or Systems for Low-rise Framed Building Walls**

C402.5.2.1.2

E1827—2011(2017)

**Standard Test Methods for Determining Airtightness of Building Using an Orifice Blower Door**

C402.5.3, C402.5.4, C406.9

~~E1918—06~~

E1918—06(2016)

**Standard Test Method for Measuring Solar Reflectance of Horizontal or Low-sloped Surfaces in the Field**

Table C402.3

E1980—11

**Standard Practice for Calculating Solar Reflectance Index of Horizontal and Low-sloped Opaque Surfaces**

Table C402.3

E2178—13

**Standard Test Method for Air Permanence of Building Materials**

C402.5.2.1.1

~~E2357—2011~~

E2357—2018

**Standard Test Method for Determining Air Leakage of Air Barriers Assemblies**

C402.5.2.1.2

F1281—2017

**Specification for Cross-linked Polyethylene/Aluminum/Cross-linked Polyethylene (PEX-AL PEX) Pressure Pipe**

Table C404.5.2.1

**F1361—2017**

**Standard Test Method for Performance of Open Deep Fat Fryers**

Table C406.12(1)

**F1484—2018**

**Standard Test Method for Performance of Steam Cookers**

Table C406.12(2)

**F1495—2014a**

**Standard Specification for Combination Oven Electric or Gas Fired**

Table C406.12(4)

**F1496—2013**

**Standard Test Method for Performance of Convection Ovens**

Table C406.12(4)

**F1696—2018**

**Standard Test Method for Energy Performance of Stationary-Rack, Door-Type Commercial Dishwashing Machines**

Table C406.12(3)

**F1920—2015**

**Standard Test Method for Performance of Rack Conveyor Commercial Dishwashing Machines**

Table C406.12(3)

**F2093—2018**

**Standard Test Method for Performance of Rack Ovens**

Table C406.12(4)

**F2144—2017**

**Standard Test Method for Performance of Large Open Vat Fryers**

Table C406.12(1)

**F2861—2017**

**Standard Test Method for Enhanced Performance of Combination Oven in Various Modes**

Table C406.12(4)

---

## **CRRC**

Cool Roof Rating Council  
2435 North Lombard Street  
Portland, OR 97217

---

**ANSI/CRRC-S100—2012**

**ANSI/CRRC-S100—2020**

**Standard Test Methods for Determining Radiative Properties of Materials**

Table C402.3, C402.3.1

---

## **CSA**

CSA Group  
8501 East Pleasant Valley Road

Cleveland, OH 44131-5516

**AAMA/WDMA/CSA 101/LS.2/A440—11**

**AAMA/WDMA/CSA 101/LS.2/A440—17**

**North American Fenestration Standard/Specification for Windows, Doors and Unit Skylights**

Table C402.5.5

**CSA B55.1—2015**

**Test Method for Measuring Efficiency and Pressure Loss of Drain Water Heat Recovery Units**

C404.7

**CSA B55.2—2015**

**Drain Water Heat Recovery Units**

C404.7

---

## CTI

Cooling Technology Institute

P. O. Box 681807

Houston, TX 77268

**ATC 105—00**

**ATC 105—2019**

**Acceptance Test Code for Water Cooling Tower**

Table C403.3.2(7)

**ATC 105DS—2018**

**Acceptance Test Code for Dry Fluid Coolers**

Table C403.3.2(7)

**ATC 105S—11**

**Acceptance Test Code for Closed Circuit Cooling Towers**

Table C403.3.2(7), Table C403.3.2(8)

**ATC 106—11**

**Acceptance Test for Mechanical Draft Evaporative Vapor Condensers**

Table C403.3.2(7), Table C403.3.2(8)

**CTI STD 201 RS(17)**

**Performance Rating of Evaporative Heat Rejection Equipment**

Table C403.3.2(7), Table C403.3.2(8)

---

## DASMA

Door & Access Systems Manufacturers Association, International

1300 Sumner Avenue

Cleveland, OH 44115-2851

**105—92(R2004)—13**

**105—2017**

**Test Method for Thermal Transmittance and Air Infiltration of Garage Doors and Rolling Doors**

C303.1.3, Table C402.5.5

---

## DOE

US Department of Energy  
c/o Superintendent of Documents  
1000 Independence Avenue SW

Washington, DC 20585

**10 CFR, Part 430—1998**



**10 CFR, Part 430—2015**

**Energy Conservation Program for Consumer Products: Test Procedures and Certification and Enforcement Requirement for Plumbing Products; and Certification and Enforcement Requirements for Residential Appliances; Final Rule**

Table C403.3.2(1), Table C403.3.2(2), Table C403.3.2(5), Table C403.3.2(6), Table C403.3.2(14),  
Table C404.2

**~~10 CFR, Part 431—2004~~**

**10 CFR, Part 431—2015**

**Energy Efficiency Program for Certain Commercial and Industrial Equipment: Test Procedures and Efficiency Standards; Final Rules**

Table C403.3.2(6), C403.8.4, C403.11, C403.11.1, Table C403.11.1, C403.11.2, C405.7, Table  
C405.7, C405.8, Table C405.8(1), Table C405.8(2), Table C405.8(3), Table C405.8(4)

---

# ICC

International Code Council, Inc.  
500 New Jersey Avenue NW 6th Floor  
Washington, DC 20001

**~~IBC—15~~**

**IBC—21**

**International Building Code®**

C201.3, C303.2, C402.5.6, C501.2

ICC 500—2020

**Standard for the Design and Construction of Storm Shelters**

C402.4.2

**~~IFC—15~~**

**IFC—21**

**International Fire Code®**

C201.3, C501.2

**~~IFGC—15~~**

**IFGC—21**

**International Fuel Gas Code®**

C201.3, C501.2

**~~IMC—15~~**

**IMC—21**

**International Mechanical Code®**

C403.2.2, C403.6, C403.6.6, C403.7.1, C403.7.2, C403.7.4.2, C403.7.5, C403.7.7, C403.12.1,  
C403.12.2.1, C403.12.2.2, C406.6, C501.2

**~~IPC—15~~**

**IPC—21**

**International Plumbing Code®**  
C201.3, C501.2

**~~IPMC—15~~**

**IPMC—21**

**International Property Maintenance Code®**  
C501.2

**~~IPSDC—15~~**

**IPSDC—21**

**International Private Sewage Disposal Code®**  
C501.2

---

## **IEEE**

Institute of Electrical and Electronic Engineers  
3 Park Avenue, 17th Floor  
New York, NY 10016

**IEEE 515.1—2012**

**IEEE Standard for the Testing, Design, Installation, and Maintenance of Electrical Resistance Trace Heating for Commercial Applications**

C404.6.2

---

## **IES**

Illuminating Engineering Society  
120 Wall Street, 17th Floor  
New York, NY 10005-4001

**~~ANSI/ASHRAE/IESNA 90.1—2013~~**

**ANSI/ASHRAE/IESNA 90.1—2019**

**Energy Standard for Buildings, Except Low-rise Residential Buildings**  
C401.2, Table C402.1.3, Table C402.1.4, C406.2, C502.1, C503.1, C504.1

---

## **ISO**

International Organization for Standardization  
Chemin de Blandonnet 8, CP 401, 1214 Vernier  
Geneva, Switzerland

**~~ISO/AHRI/ASHRAE 13256-1(2011)~~**

**ISO/AHRI/ASHRAE 13256-1(2017)**

**Water-to-Air and Brine-to-Air Heat Pumps—Testing and Rating for Performance**  
Table C403.3.2(14)

**~~ISO/AHRI/ASHRAE 13256-2(2011)~~**

**ISO/AHRI/ASHRAE 13256-2(2017)**

**Water-to-Water and Brine-to-Water Heat Pumps—Testing and Rating for Performance**

---

## NEMA

National Electrical Manufacturers Association  
1300 North 17th Street, Suite 900  
Rosslyn, VA 22209

~~MG1—1993~~

MG1—2016

Motors and Generators  
C202

---

## NFPA

National Fire Protection Association  
1 Batterymarch Park  
Quincy, MA 02169-7471

~~70—14~~

70—20

National Electrical Code C501.2

---

## NFRC

National Fenestration Rating Council, Inc.  
6305 Ivy Lane, Suite 140  
Greenbelt, MD 20770

~~100—2009~~

100—2020

Procedure for Determining Fenestration Products *U*-factors  
C303.1.3, Table 402.1.4, C402.2.1.5, C402.4.1.1

~~200—2009~~

200—2020

Procedure for Determining Fenestration Product Solar Heat Gain Coefficients and Visible Transmittance at Normal Incidence  
C303.1.3, C402.4.1.1

203—2017

Procedure for Determining Translucent Fenestration Product Visible Transmittance at Normal Incidence  
C303.1.3

~~400—2012~~

400—2020

Procedure for Determining Fenestration Product Air Leakage  
Table C402.5.5

---

## SMACNA

Sheet Metal and Air Conditioning Contractors' National Association, Inc.  
4021 Lafayette Center Drive  
Chantilly, VA 20151-1219

SMACNA—2012

HVAC Air Duct Leakage Test Manual Second Edition  
C403.2.8.1.3

---

## UL

UL LLC  
333 Pfingsten Road

Northbrook, IL 60062-2096

710—12

Exhaust Hoods for Commercial Cooking Equipment—with Revisions through November 2013  
C403.7.5

727—06

727—18

Oil-fired Central Furnaces  
Table C403.3.2(4), Table C403.3.2(5)

731—95

731—18

Oil-fired Unit Heaters  
Table C403.3.2(5)

1784—15

Air Leakage Tests of Door Assemblies—with Revisions through February 2015  
C402.5.6, C402.5.7

---

## US-FTC

United States-Federal Trade Commission  
600 Pennsylvania Avenue NW  
Washington, DC 20580

~~CFR Title 16 (2005)~~

CFR Title 16 (2015)

R-value Rule  
C303.1.4

---

## WDMA

Window and Door Manufacturers Association  
2025 M Street NW, Suite 800  
Washington, DC 20036-3309

~~AAMA/WDMA/CSA 101/LS.2/A440—11~~

AAMA/WDMA/CSA 101/LS.2/A440—17

North American Fenestration Standard/Specification for Windows, Doors and Unit Skylights  
Table C402.5.5

**APPENDIX C1**

**STATEMENT OF SYSTEM COMMISSIONING**

**Part 1: Mechanical**

Project Name: \_\_\_\_\_

Project Location: \_\_\_\_\_

In my professional opinion, the HVAC systems have been installed in substantial compliance with the intent of the approved project plans and specifications based on a site observation performed and upon **review of the following:**

YES	NO	NOT REQUIRED	ITEMS	COMMENTS
			Testing and Balance Reports	
			Operations and Maintenance Manuals for HVAC	
			HVAC Equipment	
			HVAC Controls and Operational Sequences	

Notes: \_\_\_\_\_  
\_\_\_\_\_  
\_\_\_\_\_  
\_\_\_\_\_  
\_\_\_\_\_  
\_\_\_\_\_  
\_\_\_\_\_  
\_\_\_\_\_

List of Deferred Tests:

\_\_\_\_\_  
\_\_\_\_\_  
\_\_\_\_\_  
\_\_\_\_\_  
\_\_\_\_\_  
\_\_\_\_\_  
\_\_\_\_\_  
\_\_\_\_\_

Name: \_\_\_\_\_

Signature: \_\_\_\_\_

Date: \_\_\_\_\_

**Seal Above:**

**Part 2: Service Water Heating**

Project Name: \_\_\_\_\_

Project Location: \_\_\_\_\_

In my professional opinion, the service water heating systems have been installed and are in substantial compliance with the intent of the approved project plans and specifications based on a site observation performed and upon review of the following:

YES	NO	NOT REQUIRED	ITEMS	COMMENTS
			Manuals for Service Water Heating	
			Service Water Heating Systems	

Notes: \_\_\_\_\_  
\_\_\_\_\_  
\_\_\_\_\_  
\_\_\_\_\_  
\_\_\_\_\_  
\_\_\_\_\_  
\_\_\_\_\_  
\_\_\_\_\_  
\_\_\_\_\_  
\_\_\_\_\_

List of Deferred Tests: \_\_\_\_\_  
\_\_\_\_\_  
\_\_\_\_\_  
\_\_\_\_\_  
\_\_\_\_\_  
\_\_\_\_\_  
\_\_\_\_\_  
\_\_\_\_\_  
\_\_\_\_\_

Name: \_\_\_\_\_

Signature: \_\_\_\_\_

Date: \_\_\_\_\_

**Seal Above:**

**Part 3: Electrical**

Project Name: \_\_\_\_\_

Project Location: \_\_\_\_\_

In my professional opinion, the lighting systems have been installed and are in substantial compliance with the intent of the approved project plans and specifications based on a site observation performed and upon **review of the following:**

YES	NO	NOT REQUIRED	ITEMS	COMMENTS
			Manuals for Lighting Systems	
			Lighting Equipment	
			Lighting Controls and Operational Sequences	

Notes: \_\_\_\_\_  
\_\_\_\_\_  
\_\_\_\_\_  
\_\_\_\_\_  
\_\_\_\_\_  
\_\_\_\_\_  
\_\_\_\_\_  
\_\_\_\_\_  
\_\_\_\_\_

List of Deferred Tests: \_\_\_\_\_  
\_\_\_\_\_  
\_\_\_\_\_  
\_\_\_\_\_  
\_\_\_\_\_  
\_\_\_\_\_  
\_\_\_\_\_  
\_\_\_\_\_

Name: \_\_\_\_\_

Signature: \_\_\_\_\_

Date: \_\_\_\_\_

**Seal Above:**

**APPENDIX CA**  
**BOARD OF APPEALS—COMMERCIAL**

*~~The provisions contained in this appendix are not mandatory.~~*

**SECTION CA101**  
**GENERAL**

Deleted. See the North Carolina Administrative Code and Policies.



## APPENDIX CB

# SOLAR-READY ZONE—COMMERCIAL

*The provisions contained in this appendix are not mandatory.*

### SECTION CB101

#### SCOPE

**CB101.1 General.** These provisions shall be applicable for new construction where solar-ready provisions are required.

### SECTION CB102

#### GENERAL DEFINITION

**SOLAR-READY ZONE.** A section or sections of the roof or building overhang designated and reserved for the future installation of a solar photovoltaic or solar thermal system.

### SECTION CB103

#### SOLAR-READY ZONE

**CB103.1 General.** A solar-ready zone shall be located on the roof of buildings that are five stories or less in height above grade plane, and are oriented between 110 degrees and 270 degrees of true north or have low-slope roofs. Solar-ready zones shall comply with Sections CB103.2 through CB103.9.

#### **Exceptions:**

1. A building with a permanently installed, on-site renewable energy system.
2. A building with a solar-ready zone that is shaded for more than 70 percent of daylight hours annually.
3. A building where the licensed design professional certifies that the incident solar radiation available to the building is not suitable for a solar-ready zone.
4. A building where the licensed design professional certifies that the solar zone area required by Section CB103.3 cannot be met because of extensive rooftop equipment, skylights, vegetative roof areas or other obstructions.

**CB103.2 Construction document requirements for a solar-ready zone.** Construction documents shall indicate the solar-ready zone.

**CB103.3 Solar-ready zone area.** The total solar-ready zone area shall be not less than 40 percent of the roof area calculated as the horizontally projected gross roof area less the area covered by skylights, occupied roof decks, vegetative roof areas and mandatory access or set back areas as required by the *International Fire Code*. The solar-ready zone shall be a single area or smaller, separated sub-zone areas. Each sub-zone shall be not less than 5 feet (1524 mm) in width in the narrowest dimension.

**CB103.4 Obstructions.** Solar ready zones shall be free from obstructions, including pipes, vents, ducts, HVAC equipment, skylights and roof-mounted equipment.

**CB103.5 Roof loads and documentation.** A collateral dead load of not less than 5 pounds per square foot (5 psf) (24.41 kg/m<sup>2</sup>) shall be included in the gravity and lateral design calculations for the solar-ready zone. The structural design loads for roof dead load and roof live load shall be indicated on the construction documents.

**CB103.6 Interconnection pathway.** Construction documents shall indicate pathways for routing of conduit or piping from the solar-ready zone to the electrical service panel and electrical energy storage system area or service hot water system.

**CB103.7 Electrical energy storage system-ready area.** The floor area of the electrical energy storage system-ready area shall be not less than 2 feet (610 mm) in one dimension and 4 feet (1219 mm) in another dimension, and located in accordance with Section 1207 of the *International Fire Code*. The location and layout diagram of the electrical energy storage system-ready area shall be indicated on the construction documents.

**CB103.8 Electrical service reserved space.** The main electrical service panel shall have a reserved space to allow installation of a dual-pole circuit breaker for future solar electric and a dual-pole circuit breaker for future electrical energy storage system installation. These spaces shall be labeled “For Future Solar Electric and Storage.” The reserved spaces shall be positioned at the end of the panel that is opposite from the panel supply conductor connection.

**CB103.9 Construction documentation certificate.** A permanent certificate, indicating the solar-ready zone and other requirements of this section, shall be posted near the electrical distribution panel, water heater or other conspicuous location by the builder or registered design professional.

## APPENDIX CC

### ZERO ENERGY COMMERCIAL BUILDING PROVISIONS

The provisions contained in this appendix are not mandatory.

#### SECTION CC101 GENERAL

**CC101.1 Purpose.** The purpose of this appendix is to supplement the *International Energy Conservation Code* and require renewable energy systems of adequate capacity to achieve net zero carbon.

**CC101.2 Scope.** This appendix applies to new buildings that are addressed by the *International Energy Conservation Code*.

#### Exceptions:

1. Detached one- and two-family dwellings and townhouses as well as Group R-2 buildings three stories or less in height above grade plane, manufactured homes (mobile dwellings), and manufactured houses (modular dwellings).
2. Buildings that use neither electricity nor fossil fuel.

#### SECTION CC102 DEFINITIONS

**CC102.1 Definitions.** The definitions contained in this section supplement or modify the definitions in the *International Energy Conservation Code*.

**ADJUSTED OFF-SITE RENEWABLE ENERGY.** The amount of energy production from off-site renewable energy systems that may be used to offset building energy.

**BUILDING ENERGY.** All energy consumed at the *building site* as measured at the site boundary. Contributions from on-site or off-site renewable energy systems shall not be considered when determining the building energy.

**ENERGY UTILIZATION INTENSITY (EUI).** The energy to enter the building or the proposed building divided by the gross conditioned floor area of the building. For the baseline building, the EUI can be divided between regulated energy use and unregulated energy use.

**OFF-SITE RENEWABLE ENERGY SYSTEM.** Renewable energy system not located on the building project.

**ON-SITE RENEWABLE ENERGY SYSTEM.** Renewable energy systems on the building project.

**RENEWABLE ENERGY SYSTEM.** Photovoltaic, solar thermal, geothermal energy and wind systems used to generate energy.

**SEMIHEATED SPACE.** <sup>2</sup> An enclosed space within a building that is heated by a heating system whose output capacity is greater than or equal to 1.4 Btu/h-ft<sup>2</sup> of floor area but is not a conditioned space.

**ZERO ENERGY PERFORMANCE INDEX (ZEPI PB/EE).** The ratio of the proposed building EUI without renewables to the baseline building EUI, expressed as a percentage.

#### SECTION CC103 MINIMUM RENEWABLE ENERGY

**CC103.1 Renewable energy.** On-site renewable energy systems shall be installed, or off-site renewable energy shall be procured to offset the building energy as calculated in Equation CC-1.

$$RE_{onsite} + RE_{offsite} \geq E_{building} \quad (\text{Equation CC-1})$$

where:

$RE_{onsite}$  = Annual site energy production from on-site renewable energy systems (see Section CC103.2).

$RE_{offsite}$  = Adjusted annual site energy production from off-site renewable energy systems that may be credited against building energy use (see Section CC103.3).

$E_{building}$  = Building energy use without consideration of renewable energy systems.

When Section C401.2.1(1) is used for compliance with the *International Energy Conservation Code*, building energy shall be determined by multiplying the gross conditioned floor area plus the gross semiheated floor area of the proposed building by an EUI selected from Table CC103.1. Use a weighted average for mixed-use buildings.

When Section C401.2.1, Item 2 or Section C401.2.2 is used for compliance with the *International Energy Conservation Code*, building energy shall be determined from energy simulations.

**TABLE CC103.1**

**ENERGY UTILIZATION INTENSITY FOR BUILDING TYPES AND CLIMATES (kBtu/ft<sup>2</sup> – yr)**

BUILDING AREA TYPE	CLIMATE ZONE																
	0A/1A	0B/1B	2A	2B	3A	3B	3C	4A	4B	4C	5A	5B	5C	6A	6B	7	8
	kBtu/ft <sup>2</sup> – yr																
Healthcare/hospital (I-2)	119	120	119	113	116	109	106	116	109	106	118	110	105	126	116	131	142
Hotel/motel (R-1)	73	76	73	68	70	67	65	69	66	65	71	68	65	77	72	81	89
Multiple-family (R-2)	43	45	41	41	43	42	36	45	43	41	47	46	41	53	48	53	59
Office (B)	31	32	30	29	29	28	25	28	27	25	29	28	25	33	30	32	36
Restaurant (A-2)	389	426	411	408	444	420	395	483	437	457	531	484	484	589	538	644	750
Retail (M)	46	50	45	46	44	44	37	48	44	44	52	50	46	60	52	64	77
School (E)	42	46	42	40	40	39	36	39	40	40	39	43	37	44	40	45	54
Warehouse (S)	9	12	9	11	12	11	10	17	13	14	23	17	15	32	23	32	32
All others	55	58	54	53	53	51	48	54	52	51	57	54	50	63	57	65	73

**CC103.2 Calculation of on-site renewable energy.** The annual energy production from on-site renewable energy systems shall be determined using the PVWatts software or other software approved by the code official.

**CC103.3 Off-site renewable energy.** Off-site energy shall comply with Sections CC103.3.1 and CC103.3.2.

**CC103.3.1 Qualifying off-site procurement methods.** The following are considered qualifying off-site renewable energy procurement methods:

1. Community renewables: an off-site renewable energy system for which the owner has purchased or leased renewable energy capacity along with other subscribers.
2. Renewable energy investment fund: an entity that installs renewable energy capacity on behalf of the owner.
3. Virtual power purchase agreement: a power purchase agreement for off-site renewable energy where the owner agrees to purchase renewable energy output at a fixed price schedule.
4. Direct ownership: an off-site renewable energy system owned by the building project owner.
5. Direct access to wholesale market: an agreement between the owner and a renewable energy developer to purchase renewable energy.
6. Green retail tariffs: a program by the retail electricity provider to provide 100-percent renewable energy to the owner.

7. Unbundled Renewable Energy Certificates (RECs): certificates purchased by the owner representing the environmental benefits of renewable energy generation that are sold separately from the electric power.

**CC103.3.2 Requirements for all procurement methods.** The following requirements shall apply to all *off-site renewable energy* procurement methods:

1. The building owner shall sign a legally binding contract to procure qualifying off-site renewable energy.
2. The procurement contract shall have duration of not less than 15 years and shall be structured to survive a partial or full transfer of ownership of the property.
3. RECs and other environmental attributes associated with the procured off-site renewable energy shall be assigned to the building project for the duration of the contract.
4. The renewable energy generating source shall include one or more of the following: photovoltaic systems, solar thermal power plants, geothermal power plants and wind turbines.
5. The generation source shall be located where the energy can be delivered to the building site by the same utility or distribution entity, the same independent system operator (ISO) or regional transmission organization (RTO), or within integrated ISOs (electric coordination council).
6. The off-site renewable energy producer shall maintain transparent accounting that clearly assigns production to the building. Records on power sent to or purchased by the building shall be retained by the building owner and made available for inspection by the code official upon request.

**CC103.3.3 Adjusted off-site renewable energy.** The process for calculating the adjusted *off-site renewable energy* is shown in Equation CC-2.

**(Equation CC-2)**

$RE_{offsite}$  = Adjusted off-site renewable energy.

$PF_i$  = Procurement factor for the  $i^{th}$  renewable energy procurement method or class taken from Table CC103.3.3.

$RE_i$  = Annual energy production for the  $i^{th}$  renewable energy procurement method or class.

$n$  = The number of renewable energy procurement options or classes considered.

CLASS	PROCUREMENT FACTOR (PF)	PROCUREMENT OPTIONS	ADDITIONAL REQUIREMENTS (see also Section CC103.3.2)
1	0.75	Community solar	=
		REIFs	Entity must be managed to prevent fraud or misuse of funds.
		Virtual PPA	=
		Self-owned off-site	Provisions shall prevent the generation from being sold separately from the building.
2	0.55	Green retail tariffs	The offering shall not include the purchase of unbundled RECs.
		Direct access	The offering shall not include the purchase of unbundled RECs.

3	0.20	<u>Unbundled RECs</u>	<u>The vintage of the RECs shall align with building energy use.</u>
---	------	-----------------------	--



# CHAPTER 1 [RE] SCOPE AND ADMINISTRATION

## PART 1—SCOPE AND APPLICATION

### SECTION R101 SCOPE AND GENERAL REQUIREMENTS

**R101.1 Title.** This code shall be known as the North Carolina Energy Conservation Code as adopted by the North Carolina Building Code Council on December 14<sup>th</sup> 2023 to be effective January 1, 2025. References to the International Codes shall mean the North Carolina Codes. The NCECC is referred to herein as “the code”.

**R101.2 Scope.** This code applies to *residential buildings, building sites* and associated systems and equipment.

**Exception:**

~~1. In accordance with N.C.G.S. 143-138 (b19), no energy conservation code provisions shall apply to detached and attached garages located on the same lot as a dwelling.~~

**R101.3 Intent.** This code shall regulate the design and construction of *buildings* for the effective use and conservation of energy over the useful life of each building. This code is intended to provide flexibility to permit the use of innovative approaches and techniques to achieve this objective. This code is not intended to abridge safety, health or environmental requirements contained in other applicable codes or ordinances.

**R101.4 Applicability.** Where, in any specific case, different sections of this code specify different materials, methods of construction or other requirements, the most restrictive shall govern. Where there is a conflict between a general requirement and a specific requirement, the specific requirement shall govern.

~~**R101.4.1 Mixed occupancy. Mixed residential and commercial buildings.** Where a building includes both *residential and commercial* occupancies, each occupancy shall be separately~~ Where a building includes both *residential building and commercial building* portions, each portion shall be separately considered and meet the applicable provisions of the IECC—Commercial Provisions or IECC—Residential Provisions.

**R101.5 Compliance.** *Residential buildings* shall meet the provisions of IECC—Residential Provisions. *Commercial buildings* shall meet the provisions of IECC—Commercial Provisions.

**R101.5.1 Compliance materials.** The *code official* shall be permitted to approve specific computer software, worksheets, compliance manuals and other similar materials that meet the intent of this code.

~~**R101.5.2 Requirements of other State Agencies, occupational licensing boards, or commissions.** The North Carolina State Building Codes do not include all additional requirements for buildings and structures that may be imposed by other State agencies, occupational licensing boards, and commissions. It shall be the responsibility of a permit holder, design professional, contractor, or occupational license holder to determine whether any additional requirements exist.~~

**101.6 Requirements of other State agencies, occupational licensing board or commissions.** -see the NC Administrative Code and Policies

### SECTION R102 ALTERNATIVE MATERIALS, DESIGN AND METHODS OF CONSTRUCTION AND EQUIPMENT

~~**R102.1 General.** Deleted. See the *North Carolina Administrative Code and Policies*.~~

**R102.1 General.** The provisions of this code are not intended to prevent the installation of any material or to prohibit any design or method of construction not specifically prescribed by this code, provided that any such alternative has been approved. The *code official* shall have the authority to approve an alternative material, design or method of construction upon the written application of the owner or the owner’s authorized agent. The code official shall first find that the proposed design is satisfactory and complies with the intent of the provisions of this code, and that the material, method or work offered is, for the purpose intended, not less than the equivalent of that prescribed in this code for strength, effectiveness, fire resistance, durability, energy



conservation and safety. The *code official* shall respond to the applicant, in writing, stating the reasons why the alternative was approved or was not approved.

~~R102.1.1 Above code programs. Deleted.~~

R102.1.1 Above code programs. The *code official* or other authority having jurisdiction shall be permitted to deem a national, state or local energy-efficiency program to exceed the energy efficiency required by this code. *Buildings approved* in writing by such an energy-efficiency program shall be considered to be in compliance with this code where such buildings also meet the requirements identified in Table R405.2 and the *building thermal envelope* is greater than or equal to levels of efficiency and solar heat gain coefficients (SHGC) in Tables 402.1.1 and 402.1.3 of the 2009 *International Energy Conservation Code*.

## PART 2—ADMINISTRATION AND ENFORCEMENT

See the North Carolina Administrative Code and Policies for the administration and enforcement of the North Carolina State Building Codes as adopted by the Building Code Council and enforced by State and local code enforcement officials.

### SECTION R103 CONSTRUCTION DOCUMENTS

**R103.1 General.** Construction documents, technical reports and other supporting data shall be submitted in one or more sets, or in a digital format where allowed by the *code official*, with each application for a permit. The construction documents and technical reports shall be prepared by a registered design professional where required by the statutes of the jurisdiction in which the project is to be constructed. Where special conditions exist, the *code official* is authorized to require necessary construction documents to be prepared by a registered design professional.

#### Exceptions:

1. The *code official* is authorized to waive the requirements for construction documents or other supporting data if the *code official* determines they are not necessary to confirm compliance with this code.
- ~~2. Construction documents for energy code compliance are not required for one- and two-family dwellings and townhouses.~~
  2. Refer to NCGS 160D-1110 (b) for statutory limitations on requirements for one-and-two family dwellings and townhouses plans.

**R103.2 Information on construction documents.** Construction documents shall be drawn to scale on suitable material. Electronic media documents are permitted to be submitted where *approved* by the *code official*. Construction documents shall be of sufficient clarity to indicate the location, nature and extent of the work proposed, and show in sufficient detail pertinent data and features of the *building*, systems and equipment as herein governed. Details shall include the following as applicable:

1. Energy compliance path.
- ~~1-2.~~ Insulation materials and their *R*-values.
- ~~2-3.~~ Fenestration *U*-factors and *solar heat gain coefficients* (SHGC).
- ~~3-4.~~ Area-weighted *U*-factor and *solar heat gain coefficients* (SHGC) calculations.
- ~~4-5.~~ Mechanical system design criteria.
5. 6. Mechanical and service water-heating systems and equipment types, sizes and efficiencies.
6. 7. Equipment and system controls.
7. 8. Duct sealing, duct and pipe insulation and location.
8. 9. Air sealing details.

**R103.2.1 Building thermal envelope depiction.** The *building thermal envelope* shall be represented on the construction documents.

**R103.3 Examination of documents.** ~~Deleted.~~ See the *North Carolina Administrative Code and Policies*.

~~R103.3.1 Approval of construction documents. Deleted.~~

~~R103.3.2 Previous approvals. Deleted.~~

~~R103.3.3 Phased approval. Deleted.~~

R103.4 Amended construction documents. Deleted. See the *North Carolina Administrative Code and Policies*.

R103.5 Retention of construction documents. Deleted. See the *North Carolina Administrative Code and Policies*.

#### **SECTION R104 FEES**

~~Deleted. See the *North Carolina Administrative Code and Policies*.~~

#### **SECTION R105 INSPECTIONS**

~~Deleted. See the *North Carolina Administrative Code and Policies*.~~

#### **SECTION R106 NOTICE OF APPROVAL**

~~Deleted. See the *North Carolina Administrative Code and Policies*.~~

#### **SECTION R107 VALIDITY**

~~Deleted. See the *North Carolina Administrative Code and Policies*.~~

### **SECTION R106R108R104 REFERENCED STANDARDS**

**R106.1R108.1R104.1 Referenced codes and standards.** The codes and standards referenced in this code shall be those indicated in Chapter 5, and such codes and standards shall be considered as part of the requirements of this code to the prescribed extent of each such reference and as further regulated in Sections **R108.1.1R104.1.1** and **R108.1.2R104.1.2**.

**R106.1.1R108.1.1R104.1.1 Conflicts.** Where conflicts occur between provisions of this code and referenced codes and standards, the provisions of this code shall apply.

**R106.1.2R108.1.2R104.1.2 Provisions in referenced codes and standards.** Where the extent of the reference to a referenced code or standard includes subject matter that is within the scope of this code, the provisions of this code, as applicable, shall take precedence over the provisions in the referenced code or standard.

**R106.2R108.2R104.2 Application of references.** References to chapter or section numbers, or to provisions not specifically identified by number, shall be construed to refer to such chapter, section or provision of this code.

**R106.3R108.3R104.3 Other laws.** The provisions of this code shall not be deemed to nullify any provisions of local, state or federal law.

#### **SECTION R108R109 STOP WORK ORDER**

~~R108.1R109.1 Authority. Deleted. See the *North Carolina Administrative Code and Policies*.~~

#### **SECTION R109R110 BOARD MEANS OF APPEALS**

~~Deleted. See the *North Carolina Administrative Code and Policies*.~~

## CHAPTER 2 [RE] DEFINITIONS

### SECTION R201 GENERAL

**R201.1 Scope.** Unless stated otherwise, the following words and terms in this code shall have the meanings indicated in this chapter.

**R201.2 Interchangeability.** Words used in the present tense include the future; words in the masculine gender include the feminine and neuter; the singular number includes the plural and the plural includes the singular.

**R201.3 Terms defined in other codes.** Terms that are not defined in this code but are defined in the *International Building Code*, *International Fire Code*, *International Fuel Gas Code*, *International Mechanical Code*, *International Plumbing Code* or the *International Residential Code* shall have the meanings ascribed to them in those codes.

**R201.4 Terms not defined.** Terms not defined by this chapter shall have ordinarily accepted meanings such as the context implies.

### SECTION R202 GENERAL DEFINITIONS

**ABOVE-GRADE WALL.** A wall more than 50 percent above grade and enclosing *conditioned space*. This includes between-floor spandrels, peripheral edges of floors, roof and basement knee walls, dormer walls, gable end walls, walls enclosing a mansard roof and *skylight* shafts.

**ACCESS (TO).** That which enables a device, appliance or equipment to be reached by *ready access* or by a means that first requires the removal or movement of a panel or similar obstruction.

**ADDITION.** An extension or increase in the *conditioned space* floor area, number of stories or height of a building or structure.

**AIR BARRIER.** One or more materials joined together in a continuous manner to restrict or prevent the passage of air through the *building thermal envelope* and its assemblies.

**AIR BARRIER MATERIAL.** Material(s) that have an air permeability not to exceed 0.004 cfm/ft<sup>2</sup> under a pressure differential of 0.3 in. water (1.57psf) (0.02 L/s.m<sup>2</sup> @ 75 Pa) when tested in accordance with ASTM E2178.

**AIR BARRIER SYSTEM.** Material(s) assembled and joined together to provide a barrier to air leakage through the building envelope. An air barrier system is a combination of air barrier materials and sealants.

**AIR IMPERMEABLE INSULATION.** ~~An insulation having an air permeance equal to or less than 0.02 L/s m<sup>2</sup> at 75 Pa pressure differential tested according to ASTM E2178 or E283 at the thickness applied.~~

**ALTERATION.** Any construction, retrofit or renovation to an existing structure other than *repair* or *addition*. Also, a change in a building, electrical, gas, mechanical or plumbing system that involves an extension, addition or change to the arrangement, type or purpose of the original installation.

**APPROVED.** ~~Acceptable to the code official for compliance with the provisions of the applicable code or referenced standard.~~  
Acceptable to the *code official*.

**APPROVED AGENCY.** An established and recognized agency that is regularly engaged in conducting tests furnishing inspection services, or furnishing product certification, where such agency has been *approved* by the *code official*.

**AUTOMATIC.** Self-acting, operating by its own mechanism when actuated by some impersonal influence, as, for example, a change in current strength, pressure, temperature or mechanical configuration (see “*Manual*”).

**BASEMENT WALL.** A wall 50 percent or more below grade and enclosing *conditioned space*.

~~**BPI ENVELOPE PROFESSIONAL.** An individual that has passed the Building Performance Institute written and field examination requirements for the Building Envelope certification and has a current certification.~~

**BUILDING.** Any structure used or intended for supporting or sheltering any use or occupancy, including any mechanical systems, service water-heating systems and electric power and lighting systems located on the building site and supporting the building.

**BUILDING SITE.** A contiguous area of land that is under the ownership or control of one entity.

**BUILDING THERMAL ENVELOPE.** The *basement walls, exterior walls, floors, ceiling, roofs* and any other *building* element assemblies that enclose *conditioned space* or provide a boundary between *conditioned space* and exempt or unconditioned space.

~~**C FACTOR (THERMAL CONDUCTANCE).** The coefficient of heat transmission (surface to surface) through a building component or assembly, equal to the time rate of heat flow per unit area and the unit temperature difference between the warm side and cold side surfaces (Btu/h · ft<sup>2</sup> · °F) [W/(m<sup>2</sup> · K)].~~

**CAVITY INSULATION.** Insulating material located between framing members.

~~**CFM25.** Cubic feet per minute of measured airflow while the forced air system is maintained at a pressure difference of 25 Pascals (0.1 inches w.e.)~~

~~**CFM50.** Cubic feet per minute of measured airflow while the building is maintained at a pressure difference of 50 Pascals (0.2 inches w.e.).~~

**CIRCULATING HOT WATER SYSTEM.** A specifically designed water distribution system where one or more pumps are operated in the service hot water piping to circulate heated water from the water-heating equipment to fixtures and back to the water-heating equipment.

**CLIMATE ZONE.** A geographical region based on climatic criteria as specified in this code.

**CLOSED CRAWL SPACE.** A foundation without wall vents that uses air sealed walls, ground and foundation moisture control, and mechanical drying potential to control crawl space moisture. Insulation may be located at the floor level or at the exterior walls

**CODE OFFICIAL.** The officer or other designated authority charged with the administration and enforcement of this code or a duly authorized representative.

**COMMERCIAL BUILDING.** For this code, all buildings that are not included in the definition of “*Residential building.*”

**CONDITIONED FLOOR AREA.** The horizontal projection of the floors associated with the *conditioned space*.

~~**CONDITIONED SPACE.** A space within a building that is provided with heating or cooling equipment or systems capable of maintaining, through design or heat loss/gain, 50°F (10°C) during the heating season or 85°F (29°C) during the cooling season, or communicates directly with a conditioned space. Spaces within the building thermal envelope are considered conditioned space.~~

**CONDITIONED SPACE.** An area, room or space that is enclosed within the *building thermal envelope* and that is directly or indirectly heated or cooled. Spaces are indirectly heated or cooled where they communicate through openings with conditioned spaces, where they are separated from conditioned spaces by uninsulated walls, floors or ceilings, or where they contain uninsulated ducts, piping or other sources of heating or cooling.

**CONTINUOUS AIR BARRIER.** A combination of materials and assemblies that restrict or prevent the passage of air through the *building thermal envelope*.

**CONTINUOUS INSULATION (ci).** Insulating material that is continuous across all structural members without thermal bridges other than fasteners and service openings. It is installed on the interior or exterior, or is integral to any opaque surface, of the *building envelope*.

**CRAWL SPACE WALL.** The opaque portion of a wall that encloses a crawl space and is partially or totally below grade.

**CURTAIN WALL.** Fenestration products used to create an external nonload-bearing wall that is designed to separate the exterior and interior environments.

**DEMAND RECIRCULATION WATER SYSTEM.** A water distribution system where one or more pumps prime the service hot water piping with heated water upon demand for hot water.

**DIMMER.** A control device that is capable of continuously varying the light output and energy use of light sources.

**DUCT.** A tube or conduit utilized for conveying air. The air passages of self-contained systems are not to be construed as air ducts.

**DUCT SYSTEM.** A continuous passageway for the transmission of air that, in addition to ducts, includes duct fittings, dampers, plenums, fans and accessory air-handling equipment and appliances.

**DWELLING UNIT.** A single unit providing complete independent living facilities for one or more persons, including permanent provisions for living, sleeping, eating, cooking and sanitation.

**DWELLING UNIT ENCLOSURE AREA.** The sum of the area of ceiling, floors, and walls separating a *dwelling unit's conditioned space* from the exterior or from adjacent conditioned or unconditioned spaces. Wall height shall be measured from the finished floor of the *dwelling unit* to the underside of the floor above.

**ENERGY ANALYSIS.** A method for estimating the annual energy use of the *proposed design* and *standard reference design* based on estimates of energy use.

**ENERGY COST.** The total estimated annual cost for purchased energy for the building functions regulated by this code, including applicable demand charges.

**ENERGY SIMULATION TOOL.** An *approved* software program or calculation-based methodology that projects the annual energy use of a *building*.

**ERI REFERENCE DESIGN.** A version of the *rated design* that meets the minimum requirements of the 2006 *International Energy Conservation Code*.

**EXTERIOR WALL.** Walls including both *above-grade walls* and *basement walls*.

**FENESTRATION.** Products classified as either *vertical fenestration* or *skylights*.

**Skylights.** Glass or other transparent or translucent glazing material installed at a slope of less than 60 degrees (1.05 rad) from horizontal including unit skylights, tubular daylighting devices, and glazing materials in solariums, sunrooms, roofs and sloped walls.

**Vertical fenestration.** Windows that are fixed or operable, opaque doors, glazed doors, glazed block and combination opaque/glazed doors composed of glass or other transparent or translucent glazing materials and installed at a slope of not less than 60 degrees (1.05 rad) from horizontal.

**FENESTRATION PRODUCT, FIELD-FABRICATED.** A fenestration product whose frame is made at the construction site of standard dimensional lumber or other materials that were not previously cut, or otherwise formed with the specific intention of being used to fabricate a fenestration product or exterior door. Field fabricated does not include site-built fenestration.

**FENESTRATION PRODUCT, SITE-BUILT.** A fenestration designed to be made up of field-glazed or field-assembled units using specific factory cut or otherwise factory-formed framing and glazing units. Examples of site-built fenestration include storefront systems, curtain walls and atrium roof systems.

**F-FACTOR.** The perimeter heat loss factor for slab-on-grade floors (Btu/h · ft · °F) [W/(m · K)].

**FULLY ENCLOSED ATTIC FLOOR SYSTEM.** ~~The ceiling insulation is enclosed on all six sides by an air barrier system, such as taped drywall below, solid framing joists on the sides, solid blocking on the ends, and solid sheathing on top which totally enclose the insulation.~~

**HEATED SLAB.** Slab-on-grade construction in which the heating elements, hydronic tubing, or hot air distribution system is in contact with, or placed within or under, the slab.

**HERS RATER.** An individual that has completed training and been certified by RESNET (Residential Energy Services Network) Accredited Rating Provider and has a current certification.

**HIGH EFFICACY LAMPS.** Compact fluorescent lamps, T-8 or smaller diameter linear fluorescent lamps, or lamps with a minimum efficacy of:

1. 60 lumens per watt for lamps over 40 watts;
  2. 50 lumens per watt for lamps over 15 watts to 40 watts;
- and
3. 40 lumens per watt for lamps 15 watts or less.

**HIGH-EFFICACY LIGHT SOURCES.** Compact fluorescent lamps, light-emitting diode (LED) lamps, T-8 or smaller diameter linear fluorescent lamps, or other lamps with an efficacy of not less than 65 lumens per watt, or luminaires with an efficacy of not less than 45 lumens per watt.

**HISTORIC BUILDING.** Any building or structure that is one or more of the following:

1. Listed, or certified as eligible for listing by the State Historic Preservation Officer or the Keeper of the National Register of Historic Places, in the National Register of Historic Places.
2. Designated as historic under an applicable state or local law.
3. Certified as a contributing resource within a National Register-listed, state-designated or locally designated historic district.

**INFILTRATION.** The uncontrolled inward air leakage into a *building* caused by the pressure effects of wind or the effect of differences in the indoor and outdoor air density or both.

**INSULATED SIDING.** A type of continuous insulation with manufacturer-installed insulating material as an integral part of the cladding product having an *R*-value of not less than R-2.

**INSULATING SHEATHING.** ~~An insulating board with a core material having a minimum *R*-value of R-2.~~

**LABELED.** Appliances, equipment, materials or products to which have been affixed a label, seal, symbol or other identifying mark of a nationally recognized testing laboratory, approved agency or other organization concerned with product evaluation that maintains periodic inspection of the production of such labeled items and whose labeling indicates either that the appliances, equipment, material or product meets identified standards or has been tested and found suitable for a specified purpose.

**LAMP.** ~~The device in a lighting fixture that provides illumination, typically a bulb, fluorescent tube, or light emitting diode (LED).~~

**LISTED.** Appliances, materials, products or services included in a list published by an organization acceptable to the *code official* and concerned with evaluation of products or services that maintains periodic inspection of production of *listed* appliances, equipment or materials or periodic evaluation of services and whose listing states either that the equipment, material, product or service meets identified standards or has been tested and found suitable for a specified purpose.

**LOW-VOLTAGE LIGHTING.** Lighting equipment powered through a transformer such as a cable conductor, a rail conductor and track lighting.

**MANUAL.** Capable of being operated by personal intervention (see “*Automatic*”).

**OCCUPANT SENSOR CONTROL.** An automatic control device that detects the presence or absence of people within an area and causes lighting, equipment or appliances to be regulated accordingly.

~~**ON-SITE RENEWABLE ENERGY.** Includes solar photovoltaic; active solar thermal that employs collection panels; heat transfer mechanical components; wind; small hydroelectric; tidal; wave energy; geothermal (core earth); biomass energy systems; landfill gas and bio-fuel based electrical production. On-site energy shall be generated on or adjacent to the project site and shall not be delivered to the project through the utility service.~~

**ON-SITE RENEWABLE ENERGY.** Energy from renewable energy resources harvested at the building site.

**OPAQUE DOOR.** A door that is not less than 50-percent opaque in surface area.

**PROPOSED DESIGN.** A description of the proposed *building* used to estimate annual energy use for determining compliance based on total building performance.

**RATED DESIGN.** A description of the proposed *building* used to determine the energy rating index.

**REGISTERED DESIGN PROFESSIONAL.** An individual who is registered or licensed to practice their respective design profession as defined by the statutory requirements of the professional registration laws of the state or jurisdiction in which the project is to be constructed. Design by a registered design professional is not required where exempt under the registration or licensure laws.

~~**READILY ACCESSIBLE.** Capable of being reached quickly for operation, renewal or inspection without requiring those to whom ready access is requisite to climb over or remove obstacles or to resort to portable ladders or access equipment (see “Accessible”).~~

**READY ACCESS (TO).** That which enables a device, appliance or equipment to be directly reached without requiring the removal or movement of any panel or similar obstruction.

**RENEWABLE ENERGY CERTIFICATE (REC).** An instrument that represents the environmental attributes of one megawatt hour of renewable energy; also known as an energy attribute certificate (EAC).

**RENEWABLE ENERGY RESOURCES.** Energy derived from solar radiation, wind, waves, tides, landfill gas, biogas, biomass or extracted from hot fluid or steam heated within the earth.

**REPAIR.** The reconstruction or renewal of any part of an existing *building* for the purpose of its maintenance or to correct damage.

**REROOFING.** The process of recovering or replacing an existing roof covering. See “*Roof recover*” and “*Roof replacement*.”

**RESIDENTIAL BUILDING.** For this code, includes detached one- and two-family dwellings and townhouses as well as *Group R-2, R-3 and R-4* buildings three stories or less in height above grade plane.

**ROOF ASSEMBLY.** A system designed to provide weather protection and resistance to design loads. The system consists of a roof covering and roof deck or a single component serving as both the roof covering and the roof deck. A roof assembly includes the roof covering, underlayment ~~roof deck, insulation, vapor retarder and interior finish~~ and roof deck and can also include a thermal barrier, an ignition barrier, insulation or a vapor retarder.

**ROOF RECOVER.** The process of installing an additional roof covering over a prepared an existing roof covering without removing the existing roof covering.

**ROOF REPAIR.** Reconstruction or renewal of any part of an existing roof for the purposes of its maintenance.

**ROOF REPLACEMENT.** The process of removing the existing roof covering, repairing any damaged substrate and installing a new roof covering.

**R-VALUE (THERMAL RESISTANCE).** The inverse of the time rate of heat flow through a body from one of its bounding surfaces to the other surface for a unit temperature difference between the two surfaces, under steady state conditions, per unit area ( $h \times ft^2 \times ^\circ F/Btu$ ) [ $m^2 \times K/W$ ].

~~**SEMI-CONDITIONED SPACE.** A space within the building thermal envelope that is not directly heated or cooled.~~

**SITE-RECOVERED ENERGY.** Waste energy recovered at the building site that is used to off-set consumption of purchased fuel or electrical energy supplies.

**SERVICE WATER HEATING.** Supply of hot water for purposes other than comfort heating.

~~**SKYLIGHT.** Glass or other transparent or translucent glazing material installed at a slope of less than 60 degrees (1.05 rad) from horizontal.~~

~~**SOLAR ENERGY SOURCE.** Source of thermal, chemical, or electrical energy derived from direct conversion of incident solar radiation at the building site.~~

**SOLAR HEAT GAIN COEFFICIENT (SHGC).** The ratio of the solar heat gain entering the space through the fenestration assembly to the incident solar radiation. Solar heat gain includes directly transmitted solar heat and absorbed solar radiation that is then reradiated, conducted or convected into the space.

**STANDARD REFERENCE DESIGN.** A version of the *proposed design* that meets the minimum requirements of this code and is used to determine the maximum annual energy use requirement for compliance based on total building performance.

**SUNROOM.** A one-story structure attached to a dwelling with a glazing area in excess of 40 percent of the gross area of the structure's *exterior walls* and roof.

**THERMAL DISTRIBUTION EFFICIENCY (TDE).** The resistance to changes in air heat as air is conveyed through a distance of air duct. TDE is a heat loss calculation evaluating the difference in the heat of the air between the air duct inlet and outlet caused by differences in temperatures between the air in the duct and the duct material. TDE is expressed as a percent difference between the inlet and outlet heat in the duct.

**THERMAL ISOLATION.** Physical and space conditioning separation from *conditioned spaces*. The *conditioned spaces* shall be controlled as separate zones for heating and cooling or conditioned by separate equipment.

**THERMOSTAT.** An automatic control device used to maintain temperature at a fixed or adjustable setpoint.

**U-FACTOR (THERMAL TRANSMITTANCE).** The coefficient of heat transmission (air to air) through a building component or assembly, equal to the time rate of heat flow per unit area and unit temperature difference between the warm side and cold side air films ( $Btu/h \times ft^2 \times ^\circ F$ ) [ $W/(m^2 \times K)$ ].

~~**VAPOR RETARDER CLASS 1.** A measure of the ability of a material or assembly to limit the amount of moisture that passes through that material or assembly. Vapor retarder class 1 is defined as 0.1 perm or less when using the desiccant method with Procedure A of ASTM E96.~~

**VENTILATION.** The natural or mechanical process of supplying conditioned or unconditioned air to, or removing such air from, any space.

**VENTILATION AIR.** That portion of supply air that comes from outside (outdoors) plus any recirculated air that has been treated to maintain the desired quality of air within a designated space.

~~**VERTICAL FENESTRATION.** Windows (fixed or moveable), opaque doors, glazed doors, glazed block and combination opaque/glazed doors composed of glass or other transparent or translucent glazing materials and installed at a slope of a least 60 degrees (1.05 rad) from horizontal.~~

**VISIBLE TRANSMITTANCE (VT).** The ratio of visible light entering the space through the fenestration product assembly to the incident visible light. Visible Transmittance includes the effects of glazing material and frame and is expressed as a number between 0 and 1.

**WHOLE HOUSE MECHANICAL VENTILATION SYSTEM.** An exhaust system, supply system, or combination thereof that is designed to mechanically exchange indoor air with outdoor air when operating continuously or through a programmed intermittent schedule to satisfy the whole house ventilation rates.



**ZONE.** A space or group of spaces within a *building* with heating or cooling requirements that are sufficiently similar so that desired conditions can be maintained throughout using a single controlling device.

# CHAPTER 3 [RE] GENERAL REQUIREMENTS

## SECTION R301 CLIMATE ZONES

**R301.1 General.** *Climate zones* from Figure R301.1 or Table R301.1 shall be used for determining the applicable requirements from Chapter 4. Locations not indicated in Table R301.1 shall be assigned a *climate zone* in accordance with Section R301.3.

**R301.2 Warm Humid counties.** In Table R301.1, Warm Humid counties are identified by an asterisk.

**R301.3 International climate zones.** Deleted. Note: Tables R301.3(1) and Table R301.3(2) contain no NC requirements but are retained for information only.

**R301.4 Tropical climate zone.** Deleted.

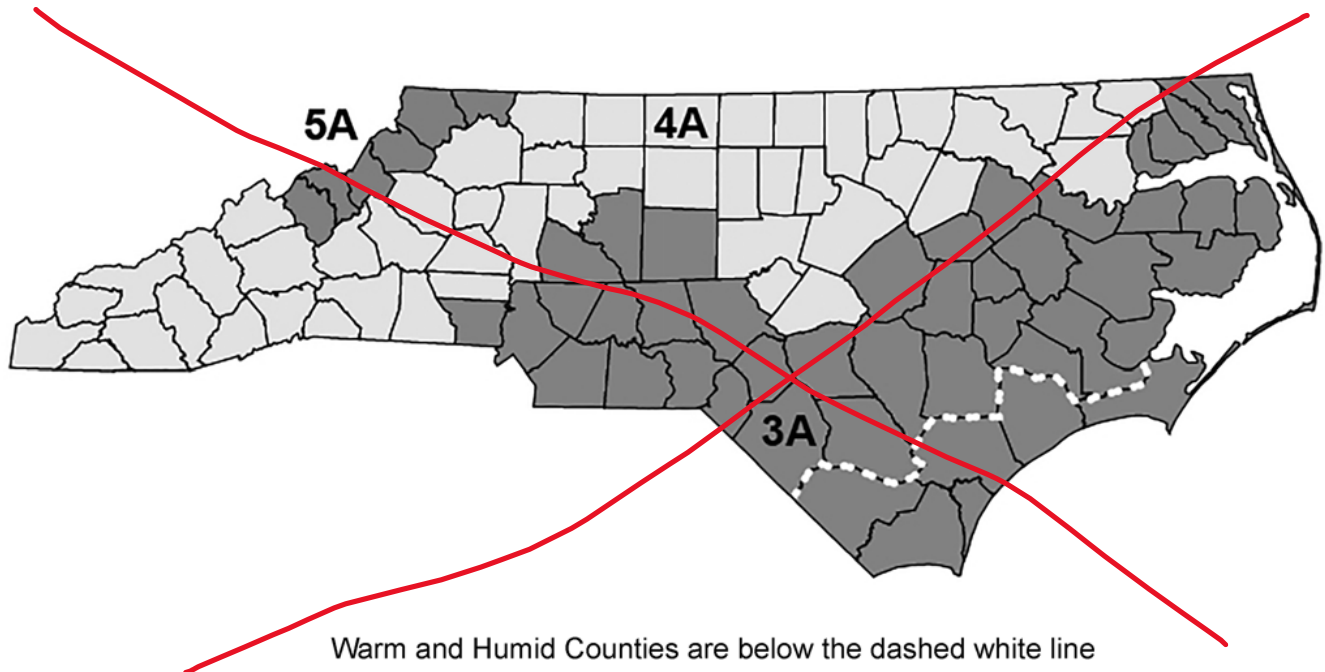
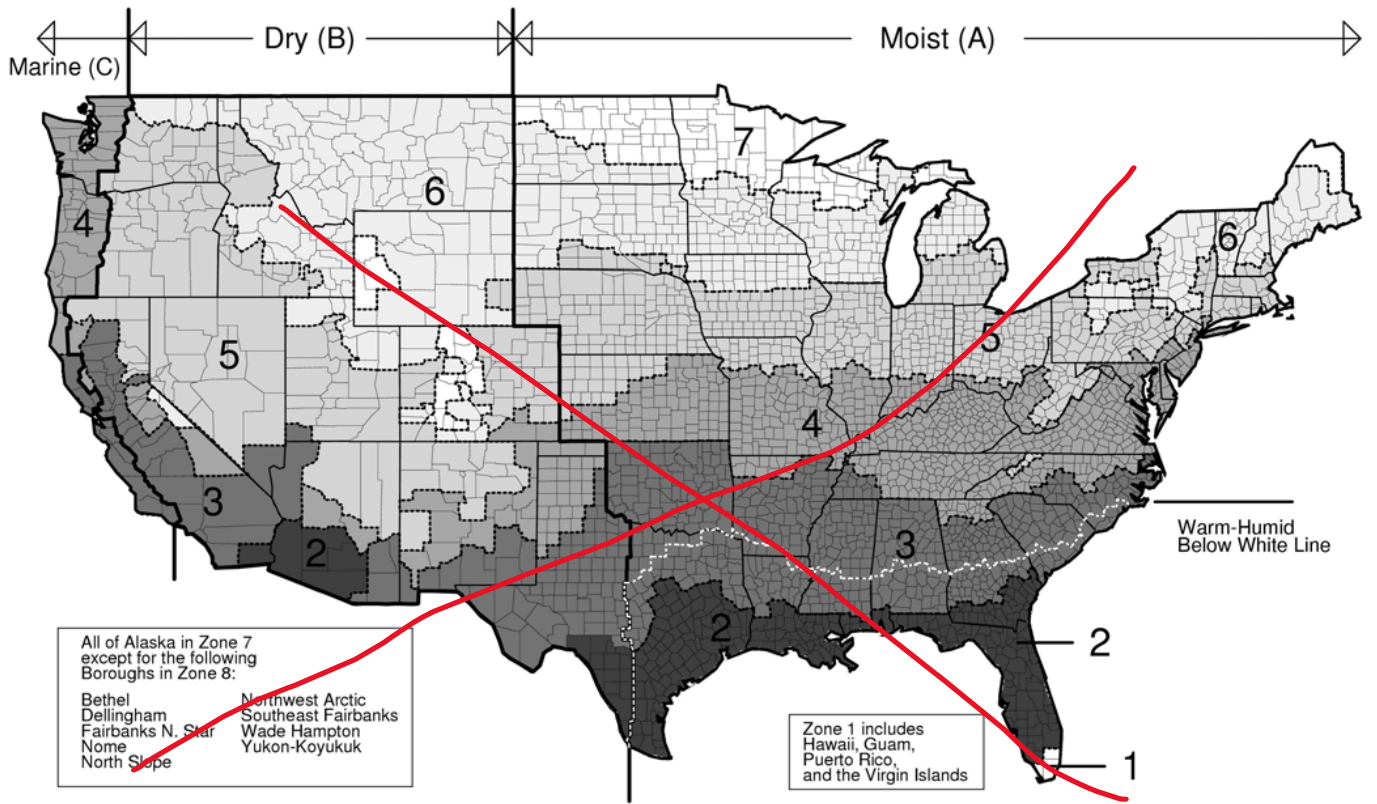

FIGURE R301.1 NORTH CAROLINA CLIMATE ZONES



**FIGURE R301.4**  
 CLIMATE ZONES

**TABLE R301.1**

**NORTH CAROLINA CLIMATE ZONES, MOISTURE REGIMES, AND WARM-HUMID DESIGNATIONS BY COUNTY**

**CLIMATE ZONES, MOISTURE REGIMES, AND WARM HUMID DESIGNATIONS BY STATE, COUNTY AND TERRITORY\***

a. Key: A – Moist, B – Dry, C – Marine. Absence of moisture designation indicates moisture regime is irrelevant. Asterisk (\*) indicates a Warm Humid location.

**NORTH CAROLINA**

- 4A Alamance 4A Alexander 5A Alleghany 3A Anson
- 5A Ashe 5A Avery
- 3A Beaufort 4A Bertie 3A Bladen
- 3A Brunswick\* 4A Buncombe 4A Burke
- 3A Cabarrus 4A Caldwell 3A Camden 3A Carteret\* 4A Caswell 4A Catawba 4A Chatham 4A Cherokee 3A Chowan 4A Clay
- 4A Cleveland 3A Columbus\* 3A Craven
- 3A Cumberland 3A Currituck 3A Dare
- 3A Davidson 4A Davie 3A Duplin 4A Durham
- 3A Edgecombe 4A Forsyth
- 4A Franklin 3A Gaston 4A Gates 4A Graham
- 4A Granville 3A Greene 4A Guilford
- 4A Halifax 4A Harnett 4A Haywood 4A Henderson 4A Hertford 3A Hoke

~~3A Hyde 4A Iredell 4A Jackson 3A Johnston 3A Jones 4A Lee~~  
~~3A Lenoir 4A Lincoln 4A Macon 4A Madison 3A Martin~~  
~~4A McDowell 3A Mecklenburg 5A Mitchell~~  
~~3A Montgomery 3A Moore~~  
~~4A Nash~~  
~~3A New Hanover\* 4A Northampton 3A Onslow\*~~  
~~4A Orange 3A Pamlico~~  
~~3A Pasquotank 3A Pender\* 3A Perquimans 4A Person~~  
~~3A Pitt 4A Polk~~  
~~3A Randolph 3A Richmond 3A Robeson~~  
~~4A Rockingham 3A Rowan~~  
~~4A Rutherford 3A Sampson 3A Scotland 3A Stanly~~  
~~4A Stokes 4A Surry 4A Swain~~  
~~4A Transylvania 3A Tyrrell~~  
~~3A Union 4A Vance 4A Wake 4A Warren~~  
~~3A Washington 5A Watauga 3A Wayne~~  
~~4A Wilkes 3A Wilson 4A Yadkin~~  
~~5A Yancey~~

NORTH CAROLINA
<u>3A</u> Alamance
<u>3A</u> Alexander
5A Alleghany
3A Anson
5A Ashe
5A Avery
3A Beaufort
<u>3A</u> Bertie
3A Bladen
3A Brunswick*
4A Buncombe
4A Burke
3A Cabarrus
4A Caldwell
3A Camden
3A Carteret*
<u>3A</u> Caswell
<u>3A</u> Catawba
<u>3A</u> Chatham
<u>3A</u> Cherokee
3A Chowan

<u>3A</u> Clay
<u>3A</u> Cleveland
3A Columbus*
3A Craven
3A Cumberland
3A Currituck
3A Dare
3A Davidson
<u>3A</u> Davie
3A Duplin
<u>3A</u> Durham
3A Edgecombe
<u>3A</u> Forsyth
<u>3A</u> Franklin
3A Gaston
<u>3A</u> Gates
4A Graham
<u>3A</u> Granville
3A Greene
<u>3A</u> Guilford
<u>3A</u> Halifax
<u>3A</u> Harnett
4A Haywood
4A Henderson
<u>3A</u> Hertford
3A Hoke
3A Hyde
<u>3A</u> Iredell
4A Jackson
3A Johnston
3A Jones
<u>3A</u> Lee

3A Lenoir
<u>3A</u> Lincoln
4A Macon
<u>4A</u> Madison
3A Martin
4A McDowell
3A Mecklenburg
<u>4A</u> Mitchell
3A Montgomery
3A Moore
<u>3A</u> Nash
3A New Hanover*
<u>3A</u> Northampton
3A Onslow*
<u>3A</u> Orange
3A Pamlico
3A Pasquotank
3A Pender*
3A Perquimans
<u>3A</u> Person
3A Pitt
<u>3A</u> Polk
3A Randolph
3A Richmond
3A Robeson
<u>3A</u> Rockingham
3A Rowan
<u>3A</u> Rutherford
3A Sampson
3A Scotland
3A Stanly
4A Stokes
4A Surry
4A Swain
4A Transylvania

3A Tyrrell
3A Union
<del>3A</del> Vance
<del>3A</del> Wake
<del>3A</del> Warren
3A Washington
5A Watauga
3A Wayne
<del>3A</del> <del>4A</del> Wilkes
3A Wilson
4A Yadkin
5A Yancey

**TABLE R301.3(4)**  
**INTERNATIONAL CLIMATE ZONE DEFINITIONS**

**MAJOR CLIMATE TYPE DEFINITIONS**

Marine (C) Definition — Locations meeting all four criteria:

2. Mean temperature of coldest month between  $-3^{\circ}\text{C}$  ( $27^{\circ}\text{F}$ ) and  $18^{\circ}\text{C}$  ( $65^{\circ}\text{F}$ ).
3. Warmest month mean  $< 22^{\circ}\text{C}$  ( $72^{\circ}\text{F}$ ).
4. At least four months with mean temperatures over  $10^{\circ}\text{C}$  ( $50^{\circ}\text{F}$ ).
4. Dry season in summer. The month with the heaviest precipitation in the cold season has at least three times as much precipitation as the month with the least precipitation in the rest of the year. The cold season is October through March in the Northern Hemisphere and April through September in the Southern Hemisphere.

Dry (B) Definition — Locations meeting the following criteria:

Not marine and  $P_{in} < 0.44 \times (TF - 19.5) - [P_{em} < 2.0 \times (TC + 7)$  in SI units]

where:

- $P_{in}$  — Annual precipitation in inches (cm)
- $T$  — Annual mean temperature in  $^{\circ}\text{F}$  ( $^{\circ}\text{C}$ )

Moist (A) Definition — Locations that are not marine and not dry.

Warm humid Definition — Moist (A) locations where either of the following wet bulb temperature conditions shall occur during the warmest six consecutive months of the year:

1.  $67^{\circ}\text{F}$  ( $19.4^{\circ}\text{C}$ ) or higher for 3,000 or more hours; or
2.  $73^{\circ}\text{F}$  ( $22.8^{\circ}\text{C}$ ) or higher for 1,500 or more hours.

**R301.3 Climate zone definitions.** To determine the climate zones for locations not listed in this code, use the following information to determine climate zone numbers and letters in accordance with Items 1 through 5.

1. Determine the thermal climate zone, 0 through 8, from Table R301.3 using the heating (HDD) and cooling degree-days (CDD) for the location.
2. Determine the moisture zone (Marine, Dry or Humid) in accordance with Items 2.1 through 2.3.

- 2.1. If monthly average temperature and precipitation data are available, use the Marine, Dry and Humid definitions to determine the moisture zone (C, B or A).
- 2.2. If annual average temperature information (including degree-days) and annual precipitation (i.e., annual mean) are available, use Items 2.2.1 through 2.2.3 to determine the moisture zone. If the moisture zone is not Marine, then use the Dry definition to determine whether Dry or Humid.
- 2.2.1. If thermal climate zone is 3 and  $CDD_{50^{\circ}F} \leq 4,500$  ( $CDD_{10^{\circ}C} \leq 2500$ ), climate zone is Marine (3C).
- 2.2.2. If thermal climate zone is 4 and  $CDD_{50^{\circ}F} \leq 2,700$  ( $CDD_{10^{\circ}C} \leq 1500$ ), climate zone is Marine (4C).
- 2.2.3. If thermal climate zone is 5 and  $CDD_{50^{\circ}F} \leq 1,800$  ( $CDD_{10^{\circ}C} \leq 1000$ ), climate zone is Marine (5C).
- 2.3. If only degree-day information is available, use Items 2.3.1 through 2.3.3 to determine the moisture zone. If the moisture zone is not Marine, then it is not possible to assign Humid or Dry moisture zone for this location.
- 2.3.1. If thermal climate zone is 3 and  $CDD_{50^{\circ}F} < 4,500$  ( $CDD_{10^{\circ}C} < 2500$ ), climate zone is Marine (3C).
- 2.3.2. If thermal climate zone is 4 and  $CDD_{50^{\circ}F} \leq 2,700$  ( $CDD_{10^{\circ}C} \leq 1500$ ), climate zone is Marine (4C).
- 2.3.3. If thermal climate zone is 5 and  $CDD_{50^{\circ}F} \leq 1,800$  ( $CDD_{10^{\circ}C} \leq 1000$ ), climate zone is Marine (5C).
3. Marine (C) Zone definition: Locations meeting all the criteria in Items 3.1 through 3.4.
- 3.1. Mean temperature of coldest month between 27°F (-3°C) and 65°F (18°C).
- 3.2. Warmest month mean < 72°F (22°C).
- 3.3. Not fewer than four months with mean temperatures over 50°F (10°C).
- 3.4. Dry season in summer. The month with the heaviest precipitation in the cold season has at least three times as much precipitation as the month with the least precipitation in the rest of the year. The cold season is October through March in the Northern Hemisphere and April through September in the Southern Hemisphere.
4. Dry (B) definition: Locations meeting the criteria in Items 4.1 through 4.4.
- 4.1. Not Marine (C).
- 4.2. If 70 percent or more of the precipitation,  $P$ , occurs during the high sun period, defined as April through September in the Northern Hemisphere and October through March in the Southern Hemisphere, then the dry/humid threshold is in accordance with Equation 3-1.
- $$\frac{P < 0.44 \times (T - 7)}{[P < 20.0 \times (T + 14) \text{ in SI units}]}$$
- (Equation 3-1)**
- where:
- $P$  = Annual precipitation, inches (mm).
- $T$  = Annual mean temperature, °F (°C).
- 4.3. If between 30 and 70 percent of the precipitation,  $P$ , occurs during the high sun period, defined as April through September in the Northern Hemisphere and October through March in the Southern Hemisphere, then the dry/humid threshold is in accordance with Equation 3-2.
- $$\frac{P < 0.44 \times (T - 19.5)}{[P < 20.0 \times (T + 7) \text{ in SI units}]}$$
- (Equation 3-2)**
- where:
- $P$  = Annual precipitation, inches (mm).
- $T$  = Annual mean temperature, °F (°C).
- 4.4. If 30 percent or less of the precipitation,  $P$ , occurs during the high sun period, defined as April through September in the Northern Hemisphere and October through March in the Southern Hemisphere, then the dry/humid threshold is in accordance with Equation 3-3.
- $$\frac{P < 0.44 \times (T - 32)}{[P < 20.0 \times T \text{ in SI units}]}$$
- (Equation 3-3)**



where:

$P$  = Annual precipitation, inches (mm).

$T$  = Annual mean temperature, °F (°C).

5. Humid (A) definition: Locations that are not Marine (C) or Dry (B).

**TABLE R301.3(2) R301.3**  
**INTERNATIONAL THERMAL CLIMATE ZONE DEFINITIONS**

ZONE NUMBER	THERMAL CRITERIA	
	IP Units	SI Units
1	$9000 < CDD50°F$	$5000 < CDD10°C$
2	$6300 < CDD50°F \leq 9000$	$3500 < CDD10°C \leq 5000$
3A and 3B	$4500 < CDD50°F \leq 6300$ AND $HDD65°F \leq 5400$	$2500 < CDD10°C \leq 3500$ AND $HDD18°C \leq 3000$
4A and 4B	$CDD50°F \leq 4500$ AND $HDD65°F \leq 5400$	$CDD10°C \leq 2500$ AND $HDD18°C \leq 3000$
3C	$HDD65°F \leq 3600$	$HDD18°C \leq 2000$
4C	$3600 < HDD65°F \leq 5400$	$2000 < HDD18°C \leq 3000$
5	$5400 < HDD65°F \leq 7200$	$3000 < HDD18°C \leq 4000$
6	$7200 < HDD65°F \leq 9000$	$4000 < HDD18°C \leq 5000$
7	$9000 < HDD65°F \leq 12600$	$5000 < HDD18°C \leq 7000$
8	$12600 < HDD65°F$	$7000 < HDD18°C$

ZONE NUMBER	THERMAL CRITERIA	
	IP Units	SI Units
0	$10,800 < CDD50°F$	$6000 < CDD10°C$
1	$9,000 < CDD50°F < 10,800$	$5000 < CDD10°C < 6000$
2	$6,300 < CDD50°F \leq 9,000$	$3500 < CDD10°C \leq 5000$
3	$CDD50°F < 6,300$ AND $HDD65°F \leq 3,600$	$CDD10°C < 3500$ AND $HDD18°C < 2000$
4	$CDD50°F < 6,300$ AND $3,600 < HDD65°F < 5,400$	$CDD10°C < 3500$ AND $2000 < HDD18°C < 3000$
5	$CDD50°F < 6,300$ AND $5,400 < HDD65°F < 7,200$	$CDD10°C < 3500$ AND $3000 < HDD18°C < 4000$
6	$7,200 < HDD65°F < 9,000$	$4000 < HDD18°C < 5000$
7	$9,000 < HDD65°F \leq 12,600$	$5000 < HDD18°C \leq 7000$
8	$12,600 < HDD65°F$	$7000 < HDD18°C$

For SI: °C = [(°F) - 32]/1.8.

**R301.4 Tropical climate region.** Deleted.

## SECTION R302 DESIGN CONDITIONS

**R302.1 Interior design conditions.** The interior design temperatures used for heating and cooling load calculations shall be a maximum of 72°F (22°C) for heating and minimum of 75°F (24°C) for cooling.

## SECTION R303 MATERIALS, SYSTEMS AND EQUIPMENT

**R303.1 Identification.** Materials, systems and equipment shall be identified in a manner that will allow a determination of compliance with the applicable provisions of this code.

**R303.1.1 Building thermal envelope insulation.** An *R*-value identification mark shall be applied by the manufacturer to each piece of *building thermal envelope* insulation that is 12 inches (305 mm) or greater in width. Alternatively, the insulation installers shall provide a certification that indicates the type, manufacturer and *R*-value of insulation installed in each element of the *building thermal envelope*. For blown-in or sprayed fiberglass and cellulose insulation, the initial installed thickness, settled thickness, settled *R*-value, installed density, coverage area and number of bags installed shall be indicated on the certification. For sprayed polyurethane foam (SPF) insulation, the installed thickness of the areas covered and the *R*-value of the installed thickness shall be indicated on the certification. For insulated siding, the *R*-value shall be on a label on the product's package and shall be indicated on the certification. The insulation installer shall sign, date and post the certification in a conspicuous location on the job site.

**Exception:** For roof insulation installed above the deck, the *R*-value shall be labeled as required by the material standards specified in Table 1508.2 of the *International Building Code* or Table R906.2 of the *International Residential Code*, as applicable.

**R303.1.1.1 Blown-in or sprayed roof and ceiling insulation.** The thickness of blown-in or sprayed fiberglass and cellulose roof and ceiling insulation shall be written in inches (mm) on markers that are installed at not less than one for every 300 square feet (28 m<sup>2</sup>) throughout the attic space. The markers shall be affixed to the trusses or joists and marked with the minimum initial installed thickness with numbers not less than 1 inch (25 mm) in height. Each marker shall face the attic access opening. The thickness and installed *R*-value of sprayed polyurethane foam insulation shall be indicated on the certification provided by the insulation installer.

**R303.1.2 Insulation mark installation.** Insulating materials shall be installed such that the manufacturer's *R*-value mark is readily observable at inspection. For insulation materials that are installed without an observable manufacturer's *R*-value mark, such as blown or draped products, an insulation certificate complying with Section R303.1.1 shall be left immediately after installation by the installer, in a conspicuous location within the building, to certify the installed *R*-value of the insulation material.

~~**R303.1.3 Fenestration product rating.** *U* factors of fenestration products (windows, doors and skylights) shall be determined in accordance with NFRC 100. *U* factors shall be determined by an accredited, independent laboratory, and labeled and certified by the manufacturer. Products lacking such a labeled *U* factor shall be assigned a default *U* factor from Table R303.1.3(1) or R303.1.3(2). The solar heat gain coefficient (SHGC) and visible transmittance (VT) of glazed fenestration products (windows, glazed doors and skylights) shall be determined in accordance with NFRC 200 by an accredited, independent laboratory, and labeled and certified by the manufacturer. Products lacking such a labeled SHGC or VT shall be assigned a default SHGC or VT from Table R303.1.3(3).~~

~~**Exception:** When a garage door is a part of the building thermal envelope, garage door *U* factors shall be determined in accordance with either NFRC 100 or ANSI/DASMA 105.~~

**R303.1.3 Fenestration product rating.** *U*-factors of fenestration products such as windows, doors and *skylights* shall be determined in accordance with NFRC 100.

**Exception:** Where required, garage door *U*-factors shall be determined in accordance with either NFRC 100 or ANSI/DASMA 105.

*U*-factors shall be determined by an accredited, independent laboratory, and labeled and certified by the manufacturer.

Products lacking such a labeled *U*-factor shall be assigned a default *U*-factor from Table R303.1.3(1) or Table R303.1.3(2). The solar heat gain coefficient (SHGC) and visible transmittance (VT) of glazed fenestration products such as windows, glazed doors and *skylights* shall be determined in accordance with NFRC 200 by an accredited, independent laboratory, and labeled and certified by the manufacturer. Products lacking such a labeled SHGC or VT shall be assigned a default SHGC or VT from Table R303.1.3(3).

**TABLE R303.1.3(1)**  
**DEFAULT GLAZED WINDOW, GLASS DOOR**  
**AND SKYLIGHT U-FACTORS**

FRAME TYPE	WINDOW AND GLASS DOOR		SKYLIGHT	
	Single pane	Double pane	Single	Double
Metal	1.20	0.80	2.00	1.30
Metal with Thermal Break	1.10	0.65	1.90	1.10
Nonmetal or Metal Clad	0.95	0.55	1.75	1.05
Glazed Block	0.60			

**TABLE R303.1.3(2)**  
**DEFAULT OPAQUE DOOR U-FACTORS**

DOOR TYPE	OPAQUE U-FACTOR
Uninsulated Metal	1.20
Insulated Metal	0.60
Wood	0.50
Insulated, nonmetal edge, not exceeding 45% glazing, any glazing double pane	0.35

**TABLE R303.1.3(3)**  
**DEFAULT GLAZED FENESTRATION SHGC AND VT**

	SINGLE GLAZED		DOUBLE GLAZED		GLAZED BLOCK
	Clear	Tinted	Clear	Tinted	
SHGC	0.8	0.7	0.7	0.6	0.6
VT	0.6	0.3	0.6	0.3	0.6

**R303.1.4 Insulation product rating.** The thermal resistance, *R*-value, of insulation shall be determined in accordance with Part 460 of US-FTC CFR Title 16 in units of  $h \times ft^2 \times ^\circ F/Btu$  at a mean temperature of 75°F (24°C).

**R303.1.4.1 Insulated siding.** The thermal resistance, *R*-value, of insulated siding shall be determined in accordance with ASTM C1363. Installation for testing shall be in accordance with the manufacturer’s instructions.

**R303.1.5 Air-impermeable insulation.** Insulation having an air permeability not greater than 0.004 cubic feet per minute per square foot [0.002 L/(s × m<sup>2</sup>)] under pressure differential of 0.3 inch water gauge (75 Pa) when tested in accordance with ASTM E2178 shall be determined air-impermeable insulation.

**R303.2 Installation.** Materials, systems and equipment shall be installed in accordance with the manufacturer’s instructions and the *International Building Code* or the *International Residential Code*, as applicable.

**R303.2.1 Protection of exposed foundation insulation.** Insulation applied to the exterior of *basement walls*, crawl space walls and the perimeter of slab-on-grade floors shall have a rigid, opaque and weather-resistant protective covering to prevent the degradation of the insulation’s thermal performance. The protective covering shall cover the exposed exterior insulation and extend not less than 6 inches (153 mm) below grade.

**R303.3 Maintenance information.** Operations and maintenance instructions and manuals shall be furnished for equipment and systems that require preventive maintenance.

## CHAPTER 4 [RE] RESIDENTIAL ENERGY EFFICIENCY

### SECTION R401 GENERAL

**R401.1 Scope.** This chapter applies to residential buildings.

**R401.2 Compliance.** Projects shall comply with one of the following:

- ~~1. Sections R401 through R404.~~
- ~~2. Section R405 and the provisions of Sections R401 through R404 labeled "Mandatory."~~
- ~~3. An energy rating index (ERI) approach in Section R406.~~
4. North Carolina specific REScheck shall be permitted to demonstrate compliance with this code. Envelope requirements may not be traded off against the use of high efficiency heating or cooling equipment. No trade off calculations are needed for required termite inspection and treatment gaps.

**R401.2 Application.** Residential buildings shall comply with Section R401.2.5 and either Sections R401.2.1, R401.2.2, or R401.2.3 .

Exception: Additions, alterations, repairs and changes of occupancy to existing buildings complying with Chapter 5.

**R401.2.1 Prescriptive Compliance Option.** The Prescriptive Compliance Option requires compliance with Sections R401 through R404.

**R401.2.2 Total Building Performance Option.** The Total Building Performance Option requires compliance with Section R405.

**R401.2.3 Energy Rating Index Option.** The Energy Rating Index (ERI) Option requires compliance with Section R406.

**R401.2.4 R401.2.4 Tropical Climate Region Option.** Deleted.

**R401.2.5 Additional energy efficiency.** This section establishes additional requirements applicable to all compliance approaches to achieve additional energy efficiency.

1. For buildings complying with Section R401.2., one of the additional efficiency package options shall be installed according to Section R408.2.
2. For buildings complying with Section R401.2.2, the building shall meet one of the following:
  - 2.1. One of the additional efficiency package options in Section R408.2 shall be installed without including such measures in the proposed design under Section R405; or
  - 2.2. The proposed design of the building under Section R405.3 shall have an annual energy cost that is less than or equal to 95 percent of the annual energy cost of the standard reference design.
3. For buildings complying with the Energy Rating Index alternative Section R401.2.3, the Energy Rating Index value shall be at least 5 percent less than the Energy Rating Index target specified in Table R406.5.

The option selected for compliance shall be identified in the certificate required by Section R401.3. \*

~~R401.2.6 REScheck Option. North Carolina approved version of REScheck shall be permitted to demonstrate compliance with this code. Envelope requirements may not be traded off against the use of high efficiency heating or cooling equipment. No tradeoff calculations are needed for required termite inspection and treatment gaps.~~

4. North Carolina-specific REScheck keyed to the 2018 IECC shall be permitted to demonstrate compliance with this code. Envelope requirements may not be traded off against the use of high efficiency heating or cooling equipment. No tradeoff calculations are needed for required termite inspection and treatment gaps.

~~**R401.3 Certificate (Mandatory).** A permanent certificate shall be posted on or in the electrical distribution panel, in the attic next to the attic insulation card, or inside a kitchen cabinet or other approved location. The certificate shall not cover or obstruct the visibility of the circuit directory label, service disconnect label or other required labels. The builder, permit holder, or registered design professional shall be responsible for completing the certificate. The certificate shall list the pre-dominant *R*-values of insulation installed in or on ceiling/roof, walls, foundation (slab, *basement wall*, *crawlspace wall* and floor) and ducts outside conditioned spaces; and the *U* factors for fenestration and the solar heat gain coefficient (SHGC) of fenestration. Where there is more than one value for each component, the certificate shall list the value covering the largest area. The certificate shall indicate whether the building air leakage was visually inspected as required in Section R402.4.2.1 or provide results of the air leakage testing required in Section R402.4.2.2. The certificate shall provide results of the duct leakage test as required in Section R403.3.3.~~

~~Appendix R1.1 contains a sample certificate.~~

~~**R401.3 Certificate.** A permanent certificate shall be completed by the builder, permit holder, registered design professional or other *approved* party . and posted on a wall in the space where the furnace is located, a utility room or an *approved* location. The permanent certificate shall be posted in a *readily accessible* location on the electrical distribution panel, in the attic next to the attic insulation card, in a utility room or other *approved* location inside the *building*. Where located on an electrical panel, the certificate shall not cover or obstruct the visibility of the circuit directory *label*, service disconnect *label* or other required labels. The certificate shall indicate the following:~~

- ~~1. The predominant *R*-values of insulation installed in or on ceilings, roofs, walls, foundation components such as slabs, *basement walls*, *crawl space walls* and floors and ducts outside *conditioned spaces*.~~
- ~~2. *U*-factors of fenestration and the *solar heat gain coefficient* (SHGC) of fenestration. Where there is more than one value for any component of the building envelope, the certificate shall indicate both the value covering the largest area and the area weighted average value if available.~~
- ~~3. The results from any required duct system and building envelope air leakage testing performed on the building.~~
- ~~4. The types, sizes and efficiencies of heating, cooling and service water-heating equipment. Where a gas-fired unvented room heater, electric furnace or baseboard electric heater is installed in the residence, the certificate shall indicate “gas-fired unvented room heater,” “electric furnace” or “baseboard electric heater,” as appropriate. An efficiency shall not be indicated for gas-fired unvented room heaters, electric furnaces and electric baseboard heaters.~~
- ~~5. Where on-site *photovoltaic panel* systems have been installed, the array capacity, inverter efficiency, panel tilt and orientation shall be noted on the certificate.~~
- ~~6. For buildings where an Energy Rating Index score is determined in accordance with Section R406, the Energy Rating Index score, both with and without any on-site generation, shall be listed on the certificate.~~
- ~~7. The code edition under which the structure was permitted, and the compliance path used.~~

~~**R401.4 Additional voluntary criteria for increasing residential energy efficiency.** Appendix R4 contains additional voluntary measures for increasing residential energy efficiency beyond code minimums. Implementation of the increased energy efficiency measures is strictly voluntary at the option of the permit holder. The sole purpose of the appendix is to provide guidance for achieving additional residential energy efficiency improvements that have been evaluated to be those that are most cost effective for achieving an additional 10 to 15 percent improvement in energy efficiency beyond code minimums.~~

**R401.4 Additional voluntary criteria for increasing residential energy efficiency.** Appendix R4 is a placeholder appendix for adding above-minimum code requirements that can be followed at the discretion of the user.

## SECTION R402 BUILDING THERMAL ENVELOPE

**R402.1 General (Prescriptive).** The *building thermal envelope* shall comply with the requirements of Sections R402.1.1 through R402.1.5.

**Exceptions:**

1. The following low-energy *buildings*, or portions thereof, separated from the remainder of the building by *building thermal envelope* assemblies complying with this section shall be exempt from the *building thermal envelope* provisions of Section R402.
  - 1.1. Those with a peak design rate of energy usage less than 3.4 Btu/h × ft<sup>2</sup> (10.7 W/m<sup>2</sup>) or 1.0 watt/ft<sup>2</sup> of floor area for space-conditioning purposes.
  - 1.2. Those that do not contain *conditioned space*.
2. Log homes designed in accordance with ICC 400.
3. ~~R402.1.1~~ Rooms containing fuel-burning appliances. In Climate Zones 3 through 5, where open combustion air ducts provide combustion air to open combustion fuel burning appliances, the appliances and combustion air opening shall be located outside the building thermal envelope or enclosed in a room that is isolated from inside the thermal envelope. Such rooms shall be sealed and insulated in accordance with the envelope requirements of Table R402.1.3, where the walls, floors and ceilings shall meet a minimum of the basement wall R-value requirement. The door into the room shall be fully gasketed and any water lines and ducts in the room insulated in accordance with Section R403. The combustion air duct shall be insulated where it passes through conditioned space to an R-value of not less than R-8.

**Exceptions:**

1. Direct vent appliances with both intake and exhaust pipes installed continuous to the outside.
2. Fireplaces and stoves complying with Section R402.4.2 and Section R1006 of the International Residential Code.

**R402.1.1 Vapor retarder.** ~~Deleted.~~ Wall assemblies in the *building thermal envelope* shall comply with the vapor retarder requirements of Section R702.7 of the *International Residential Code* or Section 1404.3 of the *International Building Code*, as applicable.

**R402.1.2 Insulation and fenestration criteria.** The *building thermal envelope* shall meet the requirements of Table R402.1.2, based on the *climate zone* specified in Chapter 3. Assemblies shall have a *U*-factor equal to or less than that specified in Table R402.1.2. Fenestration shall have a *U*-factor and glazed fenestration SHGC equal to or less than that specified in Table R402.1.2.

**R402.1.3 R-value alternative.** Assemblies with *R*-value of insulation materials equal to or greater than that specified in Table R402.1.3 shall be an alternative to the *U*-factor in Table R402.1.2 □

~~R402.1.3~~ **R402.1.4 R-value computation.** Insulation material used in layers, such as framing cavity insulation, or continuous insulation shall be summed to compute the corresponding component *R* value. The manufacturer's settled *R* value shall be used for blown insulation. Cavity insulation alone shall be used to determine compliance with the cavity insulation *R*-value requirements in Table R402.1.3. Where cavity insulation is installed in multiple layers, the *R*-values of the cavity insulation layers shall be summed to determine compliance with the cavity insulation *R*-value requirements. The manufacturer's settled *R*-value shall be used for blown-in insulation. Continuous insulation (ci) alone shall be used to determine

compliance with the continuous insulation R-value requirements in Table R402.1.3. Where continuous insulation is installed in multiple layers, the R-values of the continuous insulation layers shall be summed to determine compliance with the continuous insulation R-value requirements. Cavity insulation R-values shall not be used to determine compliance with the continuous insulation R-value requirements in Table R402.1.3. Computed R-values shall not include an R-value for other building materials or air films. Where insulated siding is used for the purpose of complying with the continuous insulation requirements of Table R402.1.3, the manufacturer's labeled R-value for the insulated siding shall be reduced by R-0.6.

~~**R402.1.4 U-factor alternative.** An assembly with a U-factor equal to or less than that specified in Table R402.1.4 shall be permitted as an alternative to the R-value in Table R402.1.2.~~

**R402.1.5 Total UA alternative.** Where the total *building thermal envelope* UA, the sum of U-factor times assembly area, is less than or equal to the total UA resulting from multiplying the U-factors in Table R402.1.2 by the same assembly area as in the proposed *building*, the *building* shall be considered to be in compliance with Table R402.1.2. The UA calculation shall be performed using a method consistent with the ASHRAE *Handbook of Fundamentals* and shall include the thermal bridging effects of framing materials. In addition to UA compliance, the SHGC requirements of Table R402.1.2 and the maximum fenestration U-factors of Section R402.5 shall be met.

North Carolina approved version of REScheck shall be permitted to demonstrate compliance with this code section. Envelope requirements may not be traded off against the use of high efficiency heating or cooling equipment. No tradeoff calculations are needed for required termite inspection and treatment gaps.

**R402.2 Specific insulation requirements (Prescriptive).** In addition to the requirements of Section R402.1, insulation shall meet the specific requirements of Sections R402.2.1 through ~~R402.2.15~~ R402.2.12.

**R402.2.1 Ceilings with attic spaces.** Where Section ~~R402.1.2~~ R402.1.3 requires ~~R-38~~ R-49 insulation in the ceiling or attic, installing ~~R-30~~ R-38 over 100 percent of the ceiling or attic area requiring insulation shall satisfy the requirement for ~~R-38~~ R-49 insulation wherever the full height of uncompressed ~~R-30~~ R-38 insulation extends over the wall top plate at the eaves. Where Section R402.1.3 requires R-60 insulation in the ceiling, installing R-49 over 100 percent of the ceiling area requiring insulation shall satisfy the requirement for R-60 insulation wherever the full height of uncompressed R-49 insulation extends over the wall top plate at the eaves. This reduction shall not apply to ~~the U-factor alternative~~ the insulation and fenestration criteria in Section R402.1.4 R402.1.2 and the Total UA alternative in Section R402.1.5.

Exceptions:

1. When insulation is installed in a fully enclosed attic floor system, as described in Appendix 1.2.1, R-30 shall be deemed compliant.
2. In roof edge and other details such as bay windows, dormers, and similar areas where the space is limited, the insulation must fill the space up to the air baffle.

Exception. In other details such as bay window and dormer roofs, and similar areas where the space is limited, the available space shall be filled with insulation for unvented details, and to the insulation baffle for vented assemblies.

~~**R402.2.2 Ceilings without attic spaces.** Where Section R402.1.2 would require R-38 insulation and the design of the roof/ceiling assembly, including cathedral ceilings, bay windows and other similar areas, does not allow sufficient space for the required insulation, the minimum required insulation for such roof/ceiling assemblies shall be R-30. This reduction of insulation from the requirements of Section R402.1.2 shall be limited to 500 square feet (46 m<sup>2</sup>) of the total insulated ceiling area. This reduction shall not apply to the U-factor alternative approach in Section R402.1.4 and the total UA alternative in Section R402.1.5.~~

**R402.2.2 Ceilings without attics.** Where Section R402.1.3 requires insulation R-values greater than R-30 in the interstitial space above a ceiling and below the structural roof deck, and the design of the roof/ceiling assembly including cathedral ceilings, dormers, bay windows and other similar areas, does not allow sufficient space for the required insulation, the minimum required insulation R-value for such roof/ceiling assemblies shall be R-30.

Insulation shall extend over the top of the wall plate to the outer edge of such plate and shall not be compressed. This reduction of insulation from the requirements of Section R402.1.3 shall be limited to 500 square feet (46 m<sup>2</sup>) or 20 percent of the total insulated ceiling area, whichever is less. This reduction shall not apply to the Total UA alternative in Section R402.1.5.

**R402.2.3 Soffit baffle.** For air-permeable insulation in vented attics, a baffle shall be installed adjacent to soffit vents. Baffles shall maintain a net free area opening equal to or greater than the size of the vent. The baffle shall extend over the top of the attic insulation. The baffle shall be permitted to be any solid material. The baffle shall be installed to the outer edge of the exterior wall top plate so as to provide maximum space for attic insulation coverage over the top plate. Where soffit venting is not continuous, baffles shall be installed continuously to prevent ventilation air in the eave /soffit from bypassing the baffle.

~~TABLE R402.1.4~~  
EQUIVALENT U-FACTORS<sup>a</sup>

CLIMATE ZONE	FENESTRATION U-FACTOR <sup>d</sup>	SKYLIGHT U-FACTOR	CEILING U-FACTOR	FRAME WALL U-FACTOR	MASS WALL U-FACTOR <sup>b</sup>	FLOOR U-FACTOR	BASEMENT WALL U-FACTOR	CRAWL SPACE WALL U-FACTOR
3	0.35	0.55	0.030	0.077	0.141	0.047	0.091 <sup>c</sup>	0.136
4	0.35	0.55	0.030	0.077	0.141	0.047	0.059	0.065
5	0.35	0.55	0.030	0.061	0.082	0.033	0.059	0.065

- a. Nonfenestration U-factors shall be obtained from measurement, calculation or an approved source.
- b. When more than half the insulation is on the interior, the mass wall U-factors shall be a maximum of 0.07 in Climate Zone 3, 0.07 in Climate Zone 4 and 0.054 in Climate Zone 5.
- c. Basement wall U-factor of 0.360 in warm-humid locations as defined by Figure R301.1 and Table R301.1.
- d. A maximum of two glazed fenestration product assemblies having a U-factor no greater than 0.55 and a SHGC no greater than 0.70 shall be permitted to be substituted for minimum code compliant fenestration product assemblies without penalty. When applying this note and using the REScheck "UA Trade-off" compliance method to allow continued use of the software, the applicable fenestration products shall be modeled as meeting the U-factor of 0.35 and the SHGC of 0.30, as applicable, but the fenestration products actual U-factor and actual SHGC shall be noted in the comments section of the software for documentation of application of this note to the applicable products. Compliance for these substitute products shall be verified compared to the allowed substituted maximum U-value requirement and maximum SHGC requirement, as applicable.

TABLE R402.1.2

MAXIMUM ASSEMBLY U-FACTORS<sup>a</sup> AND FENESTRATION REQUIREMENTS

CLIMATE ZONE	FENESTRATION U-FACTOR <sup>f</sup>	SKYLIGHT U-FACTOR	GLAZED FENESTRATION SHGC <sup>d,e</sup>	CEILING U-FACTOR <sup>g</sup>	WOOD FRAME WALL U-FACTOR	MASS WALL U-FACTOR <sup>b</sup>	FLOOR U-FACTOR	BASEMENT WALL U-FACTOR	CRAWL SPACE WALL U-FACTOR
3	0.30	0.55	0.25	0.026	0.060	0.098	0.047	0.091 <sup>c</sup>	0.136
4	0.30	0.55	0.40	0.024	0.045	0.098	0.047	0.059	0.065
5	0.30	0.55	NR	0.024	0.045	0.082	0.033	0.050	0.055

For SI: 1 foot = 304.8 mm.

- a. Nonfenestration U-factors shall be obtained from measurement, calculation or an approved source.
- b. Mass walls shall be in accordance with Section R402.2.5. Where more than half the insulation is on the interior, the mass wall U-factors shall not exceed 0.12 in Climate Zone 3, 0.087 in Climate Zone 4, 0.065 in Climate Zone 5.
- c. In Warm Humid locations as defined by Figure R301.1 and Table R301.1, the basement wall U-factor shall not exceed 0.360.
- d. The SHGC column applies to all glazed fenestration.
- Exception:** In Climate Zones 0 through 3, skylights shall be permitted to be excluded from glazed fenestration SHGC requirements provided that the SHGC for such skylights does not exceed 0.30.
- e. Deleted.
- f. A maximum U-factor of 0.32 shall apply to vertical fenestration products installed in buildings located either:
1. Above 4,000 feet in elevation above sea level, or
  2. In windborne debris regions where protection of openings is required by Section R301.2.1.2 of the *International Residential Code*.
- g. Roofs insulated at the deck (above, below, or combination) shall meet the U-factors for the climate zone of the building location.



**TABLE R402.1.2  
INSULATION AND FENESTRATION REQUIREMENTS BY COMPONENT<sup>a</sup>**

CLIMATE ZONE	FENESTRATION U-FACTOR <sup>b,1</sup>	SKYLIGHT U-FACTOR	GLAZED FENESTRATION SHGC <sup>b,2</sup>	CEILING R-VALUE <sup>m</sup>	WOOD FRAME WALL R-VALUE	MASS WALL R-VALUE <sup>i</sup>	FLOOR R-VALUE	BASEMENT <sup>c,d</sup> WALL R-VALUE	SLAB <sup>d</sup> R-VALUE & DEPTH	CRAWL SPACE <sup>c</sup> WALL R-VALUE
3	0.35	0.55	0.30	38 or 30ci <sup>1</sup>	15 or 13+2.5 <sup>h</sup>	5/13 or 5/10ci	19	5/13 <sup>f</sup>	0	5/13
4	0.35	0.55	0.30	38 or 30ci <sup>1</sup>	15 or 13+2.5 <sup>h</sup>	5/13 or 5/10ci	19	10/15	10	10/15
5	0.25	0.55	NR	38 or 30ci <sup>1</sup>	19 <sup>a</sup> or 13+5 <sup>h</sup> or 15+3 <sup>h</sup>	13/17 or 13/12.5ci	30 <sup>e</sup>	10/15	10	10/19

For SI: 1 foot = 304.8 mm.

- a. R-values are minimums. U-factors and SHGC are maximums. When insulation is installed in a cavity which is less than the label or design thickness of the insulation, the installed R-value of the insulation shall not be less than the R-value specified in the table.
- b. The fenestration U-factor column excludes skylights. The SHGC column applies to all glazed fenestration.
- c. "10/15" means R-10 continuous insulated sheathing on the interior or exterior of the home or R-15 cavity insulation at the interior of the basement wall or crawl space wall.
- d. For monolithic slabs, insulation shall be applied from the inspection gap downward to the bottom of the footing or a maximum of 24 inches below grade, whichever is less. For floating slabs, insulation shall extend to the bottom of the foundation wall or 24 inches, whichever is less. (See Appendix R2). R-5 shall be added to the required slab edge R-values for heated slabs.
- e. Deleted.
- f. Basement wall insulation is not required in warm humid locations as defined by Figure R301.1 and Table R301.1.
- g. Or insulation sufficient to fill the framing cavity, R-19 minimum.
- h. The first value is cavity insulation, the second value is continuous insulation, so "13+5" means R-13 cavity insulation plus R-5 continuous insulation. If structural sheathing covers 25 percent or less of the exterior, insulating sheathing is not required where structural sheathing is used. If structural sheathing covers more than 25 percent of exterior, structural sheathing shall be supplemented with insulated sheathing of at least R-2.
- i. The second R-value applies when more than half the insulation is on the interior of the mass wall.
- j. In addition to the exemption in Section R402.3.3, a maximum of two glazed fenestration product assemblies having a U-factor no greater than 0.55 shall be permitted to be substituted for minimum code compliant fenestration product assemblies without penalty.
- k. In addition to the exemption in Section R402.3.3, a maximum of two glazed fenestration product assemblies having a SHGC no greater than 0.70 shall be permitted to be substituted for minimum code compliant fenestration product assemblies without penalty.
- l. R-30 shall be deemed to satisfy the ceiling insulation requirement wherever the full height of uncompressed R-30 insulation extends over the wall top plate at the eaves. Otherwise R-38 insulation is required where adequate clearance exists or insulation must extend to either the insulation baffle or within 1 inch of the attic roof deck.
- m. Table value required except for roof edge where the space is limited by the pitch of the roof; there the insulation must fill the space up to the air baffle.
- n. R-19 fiberglass batts compressed and installed in a nominal 2 x 6 framing cavity is deemed to comply. Fiberglass batts rated R-19 or higher compressed and installed in a 2 x 4 wall is not deemed to comply.
- o. Basement wall meeting the minimum mass wall specific heat content requirement may use the mass wall R-value as the minimum requirement.

**TABLE R402.1.3  
INSULATION MINIMUM R-VALUES AND FENESTRATION REQUIREMENTS BY COMPONENT<sup>a</sup>**

CLIMATE ZONE	FENESTRATION U-FACTOR <sup>b,1</sup>	SKYLIGHT U-FACTOR	GLAZED FENESTRATION SHGC <sup>b,2</sup>	CEILING R-VALUE	WOOD FRAME WALL R-VALUE <sup>g</sup>	MASS WALL R-VALUE <sup>h</sup>	FLOOR R-VALUE	BASEMENT <sup>c,g</sup> WALL R-VALUE	SLAB <sup>d</sup> R-VALUE & DEPTH	CRAWL SPACE <sup>c,g</sup> WALL R-VALUE
3	.30	0.55	0.25	49	20 or 13 + 5ci or 0 + 15	8/13	19	5ci or 13 <sup>f</sup>	10ci, 2 ft	5ci or 13 <sup>f</sup>
4	.30	0.55	0.40	60	20 + 5 or 13 + 10ci or 0 + 15	8/13	19	10ci or 13	10ci, 4 ft	10ci or 13
5	0.30 <sup>i</sup>	0.55	0.40	60	20 + 5 or 13 + 10ci or 0 + 15	13/17	30	15ci or 19 or 13 + 5ci	10ci, 4 ft	15ci or 19 or 13 + 5ci

For SI: 1 foot = 304.8 mm.

NR = Not Required.

ci = continuous insulation.

- a. R-values are minimums. U-factors and SHGC are maximums. Where insulation is installed in a cavity that is less than the label or design thickness of the insulation, the installed R-value of the insulation shall be not less than the R-value specified in the table.

- b. The fenestration *U*-factor column excludes skylights. The SHGC column applies to all glazed fenestration.  
Exception: In Climate Zones 0 through 3, skylights shall be permitted to be excluded from glazed fenestration SHGC requirements provided that the SHGC for such skylights does not exceed 0.30.
- c. "5ci or 13" means R-5 continuous insulation (ci) on the interior or exterior surface of the wall or R-13 cavity insulation on the interior side of the wall. "10ci or 13" means R-10 continuous insulation (ci) on the interior or exterior surface of the wall or R-13 cavity insulation on the interior side of the wall. "15ci or 19 or 13 + 5ci" means R-15 continuous insulation (ci) on the interior or exterior surface of the wall; or R-19 cavity insulation on the interior side of the wall; or R-13 cavity insulation on the interior of the wall in addition to R-5 continuous insulation on the interior or exterior surface of the wall.
- d. R-5 insulation shall be provided under the full slab area of a heated slab in addition to the required slab edge insulation *R*-value for slabs, as indicated in the table. The slab-edge insulation for heated slabs shall not be required to extend below the slab.
- e. There are no SHGC requirements in the Marine Zone.
- f. Basement wall insulation is not required in Warm Humid locations as defined by Figure R301.1 and Table R301.1. □
- g. The first value is cavity insulation; the second value is continuous insulation. Therefore, as an example, "13 + 5" means R-13 cavity insulation plus R-5 continuous insulation.
- h. Mass walls shall be in accordance with Section R402.2.5. The second *R*-value applies where more than half of the insulation is on the interior of the mass wall.
- i. A maximum *U*-factor of 0.32 shall apply in Climate Zone 5 to vertical fenestration products installed in buildings located either:
1. Above 4,000 feet in elevation, or
  2. In windborne debris regions where protection of openings is required by Section R301.2.1.2 of the *International Residential Code*.
- j. Roofs insulated at the deck (above, below, or combination) shall meet the *U*-factors in Table R402.1.2.

**R402.2.4 Access hatches and doors.** ~~Horizontal access hatches from conditioned spaces to unconditioned spaces such as attics and crawl spaces shall be weatherstripped and insulated to an R-10 minimum value and vertical doors to such spaces shall be weatherstripped and insulated to R-5. Access shall be provided to all equipment that prevents damaging or compressing the insulation. A wood framed or equivalent baffle or retainer is required to be provided when loose fill insulation is installed, the purpose of which is to prevent the loose fill insulation from spilling into the living space when the attic access is opened, and to provide a permanent means of maintaining the installed *R* value of the loose fill insulation.~~

**Exception:**

1. ~~Full size vertical doors that provide access from conditioned to unconditioned spaces shall be permitted to meet the fenestration requirements of Table R402.1.2 based on the applicable climate zone specified in Chapter 3.~~
2. ~~Pull down stair systems shall be weatherstripped and insulated with a minimum R-5 insulation. The insulation shall not interfere with proper operation of the stair. Nonrigid insulation materials are not allowed. Additional insulation systems that enclose the stair system from above are allowed. Exposed foam plastic must meet the provisions of the Building Code or Residential Code, respectively.~~

**R402.2.4 Access hatches and doors.** Access hatches and doors from conditioned to unconditioned spaces such as attics and crawl spaces shall be insulated to the same *R*-value required by Table R402.1.3 for the wall or ceiling in which they are installed.

**Exceptions:**

1. Vertical doors providing access from conditioned spaces to unconditioned spaces that comply with the fenestration requirements of Table R402.1.3 based on the applicable climate zone specified in Chapter 3.
2. Horizontal pull-down, stair-type access hatches in ceiling assemblies that provide access from conditioned to unconditioned spaces in Climate Zones 3,4, & 5 shall not be required to comply with the insulation level of the surrounding surfaces provided the hatch meets all of the following:
  - 2.1. The average *U*-factor of the hatch shall be less than or equal to U-0.10 or have an average insulation *R*-value of R-10 or greater.

2.2. Not less than 75 percent of the panel area shall have an insulation *R*-value of R-13 or greater.

2.3. The net area of the framed opening shall be less than or equal to 13.5 square feet (1.25 m<sup>2</sup>).

2.4. The perimeter of the hatch edge shall be weatherstripped.

The reduction shall not apply to the total UA alternative in Section R402.1.5.

**R402.2.4.1 Access hatches and door insulation installation and retention.** Vertical or horizontal access hatches and doors from *conditioned spaces to unconditioned spaces* such as attics and crawl spaces shall be weatherstripped. Access that prevents damaging or compressing the insulation shall be provided to all equipment. Where loose-fill insulation is installed, a wood-framed or equivalent baffle or retainer, or dam shall be installed to prevent the loose-fill insulation from spilling into the living spaces, from higher to lower sections of the attic and from attics covering conditioned spaces to unconditioned spaces. The baffle or retainer shall provide a permanent means of maintaining the installed *R*-value of the loose-fill insulation. □

**R402.2.5 Mass walls.** Mass walls for the purposes of this chapter shall be considered walls of concrete block, concrete, insulated concrete form (ICF), masonry cavity, brick (other than brick veneer), earth (adobe, compressed earth block, rammed earth) and solid timber/logs, or any other walls meeting the following:

~~Masonry or concrete walls having a mass greater than or equal to 30 pounds per square foot (146 kg/m<sup>2</sup>). Solid wood walls having a mass greater than 20 pounds per square foot (98 kg/m<sup>2</sup>). Any walls having a heat capacity greater than or equal to 6 Btu/ft<sup>2</sup> · °F [266 J/(m<sup>2</sup> · K)].~~

- Masonry or concrete walls having a mass greater than or equal to 30 pounds per square foot (146 kg/m<sup>2</sup>).
- Solid wood walls having a mass greater than 20 pounds per square foot (98 kg/m<sup>2</sup>).
- Any walls having a heat capacity greater than or equal to 6 Btu/ft<sup>2</sup> · °F [266 J/(m<sup>2</sup> · K)].

**R402.2.6 Steel-frame ceilings, walls and floors.** Steel-frame ceilings, walls, and floors shall ~~meet~~ **comply with** the insulation requirements of Table R402.2.6 or the *U*-factor requirements of ~~Table R402.1.4~~ **R402.1.2**. The calculation of the *U*-factor for a steel-frame envelope assembly shall use a series-parallel path calculation method.

**TABLE R402.2.6  
STEEL-FRAME CEILING, WALL AND  
FLOOR INSULATION *R*-VALUES**

WOOD FRAME <i>R</i> -VALUE REQUIREMENT	COLD-FORMED STEEL-FRAME EQUIVALENT <i>R</i> -VALUE <sup>a</sup>
Steel Truss Ceilings <sup>b</sup>	
R-30	R-38 or R-30 + 3 or R-26 + 5
R-38	R-49 or R-38 + 3
R-49	R-38 + 5
Steel Joist Ceilings <sup>b</sup>	
R-30	R-38 in 2 × 4 or 2 × 6 or 2 × 8 R-49 in any framing
R-38	R-49 in 2 × 4 or 2 × 6 or 2 × 8 or 2 × 10
Steel-frame Wall, 16 inches on center	
R-13	<del>R-19+2.1</del> R-13 + 4.2 or R-21 + 2.8 or R-0 + 9.3 or R-15 + 3.8 or <u>R-21 + 3.1</u>

$R-13+3$ $R-13 + \frac{5}{8}$	$R-0 + 11.2$ $R-0 + 15$ or $R-13 + 6.1$ $R-13 + 9$ or $R-15 + 5.7$ $R-15 + 8.5$ or $R-19 + 5.0$ $R-19 + 8$ or $R-21 + 4.7$ $R-21 + 7$
$R-13 + 10$	$R-0 + 20$ or $R-13 + 15$ or $R-15 + 14$ or $R-19 + 13$ or $R-21 + 13$
R-20	$R-0 + 14.0$ or $R-13 + 8.9$ or $R-15 + 8.5$ or $R-19 + 7.8$ or $R-21 + 7.5$
$R-20 + 5$	$R-13 + 12.7$ or $R-15 + 12.3$ or $R-19 + 11.6$ or $R-21 + 11.3$ or $R-25 + 10.9$
R-21	$R-0 + 14.6$ or $R-13 + 9.5$ or $R-15 + 9.1$ or $R-19 + 8.4$ or $R-21 + 8.1$ or $R-25 + 7.7$
Steel-frame Wall, 24 inches on center	
R-13	$R-0 + 9.3$ or $R-13 + 3.0$ or $R-15 + 2.4$
$R-13 + 3$	$R-0 + 11.2$ or $R-13 + 4.9$ or $R-15 + 4.3$ or $R-19 + 6.3$ or $R-21 + 5.9$
$R-13 + 5$	$R-0 + 15$ or $R-13 + 7.5$ or $R-15 + 7$ or $R-19 + 6$ or $R-21 + 6$
$R-13 + 10$	$R-0 + 20$ or $R-13 + 13$ or $R-15 + 12$ or $R-19 + 11$ or $R-21 + 11$
R-20	$R-0 + 14.0$ or $R-13 + 7.7$ or $R-15 + 7.1$ or $R-19 + 6.3$ or $R-21 + 5.9$
$R-20 + 5$	$R-13 + 11.5$ or $R-15 + 10.9$ or $R-19 + 10.1$ or $R-21 + 9.7$ or $R-25 + 9.1$
R-21	$R-0 + 14.6$ or $R-13 + 8.3$ or $R-15 + 7.7$ or $R-19 + 6.9$ or $R-21 + 6.5$ or $R-25 + 5.9$
Steel Joist Floor	
R-13	$R-19$ in $2 \times 6$ , or $R-19 + 6$ in $2 \times 8$ or $2 \times 10$
R-19	$R-19 + 6$ in $2 \times 6$ , or $R-19 + 12$ in $2 \times 8$ or $2 \times 10$

- a. The first value is cavity insulation  $R$ -value; the second value is continuous insulation  $R$ -value. Therefore, for example, “ $R-30 + 3$ ” means  $R-30$  cavity insulation plus  $R-3$  continuous insulation.
- b. Insulation exceeding the height of the framing shall cover the framing.

**R402.2.8 Floors.** ~~Floor framing cavity insulation shall be installed to maintain permanent contact with the underside of the subfloor decking. The distance between tension support wires or other devices that hold the floor insulation in place against the subfloor shall be no more than 18 inches. In addition, supports shall be located no further than 6 inches from each end of the insulation.~~

~~**Exception:** An enclosed floor cavity such as garage ceilings, cantilevers or buildings on pilings with an enclosed floor cavity with the insulation fully in contact with the lower air barrier. In this case, the band boards shall be insulated to maintain thermal envelope continuity.~~

**R402.2.8 R402.2.7 Floors.** Floor cavity insulation shall comply with one of the following:

1. Installation shall be installed to maintain permanent contact with the underside of the subfloor decking in accordance with manufacturer instructions to maintain required  $R$ -value or readily fill the available cavity space. The distance between tension support wires or other devices that hold the floor insulation in place against the subfloor shall be no more than 18 inches. In addition, supports shall be located no further than 6 inches from each end of the insulation.

2. Floor framing cavity insulation shall be permitted to be in contact with the top side of sheathing/gypsum separating the cavity and the unconditioned space below. Insulation shall extend from the bottom to the top of all perimeter floor framing members (the band boards) and the framing members shall be air sealed.
3. A combination of cavity and continuous insulation shall be installed so that the cavity insulation is in contact with the top side of the continuous insulation that is installed on the underside of the floor framing separating the cavity and the unconditioned space below. The combined R-value of the cavity and continuous insulation shall equal the required R-value for floors. Insulation shall extend from the bottom to the top of all perimeter floor framing members and the framing members shall be air sealed. □

~~**R402.2.9 Basement walls.** Walls associated with conditioned basements shall be insulated from the top of the *basement wall* down to 10 feet (3048 mm) below grade or to the basement floor, whichever is less. Walls associated with unconditioned basements shall meet this requirement unless the floor overhead is insulated in accordance with Sections R402.1.2 and R402.2.8. Foam plastic insulation applied to exterior of basement walls shall be provided with termite inspection and treatment gaps in accordance with Appendix R2.~~

**R402.2.8 Basement walls.** Basement walls shall be insulated in accordance with Table R402.1.3.

**Exception:** Basement walls associated with unconditioned basements where all of the following requirements are met:

1. The floor overhead, including the underside stairway stringer leading to the basement, is insulated in accordance with Section R402.1.3 and applicable provisions of Sections R402.2 and R402.2.7.
2. There are no uninsulated duct, domestic hot water, or hydronic heating surfaces exposed to the basement.
3. There are no HVAC supply or return diffusers serving the basement.
4. The walls surrounding the stairway and adjacent to conditioned space are insulated in accordance with Section R402.1.3 and applicable provisions of Section R402.2.
5. The door(s) leading to the basement from conditioned spaces are insulated in accordance with Sections R402.1.3 and applicable provisions of Section R402.2, and weatherstripped in accordance with Section R402.4.
6. The building thermal envelope separating the basement from adjacent conditioned spaces complies with Section R402.4.

~~**R402.2.8.1 Basement wall insulation installation.** Where *basement walls* are insulated, the insulation shall be installed from the top of the *basement wall* down to 10 feet (3048 mm) below grade or to the basement floor, whichever is less. Foam plastic insulation applied to exterior of basement walls shall be provided with termite inspection and treatment gaps in accordance with Appendix R2.~~

~~**R402.2.10 Slab-on-grade floors.** Slab-on-grade floors with a floor surface less than 12 inches (305 mm) below grade shall be insulated in accordance with Table R402.1.2. The top edge of the insulation installed between the *exterior wall* and the edge of the interior slab shall be permitted to be cut at a 45 degree (0.79 rad) angle away from the *exterior wall*. Slab edge insulation shall have a 2-inch termite inspection gap consistent with Appendix R2 of this code.~~

**R402.2.9 Slab-on-grade floors.** Slab-on-grade floors with a floor surface less than 12 inches (305 mm) below grade shall be insulated in accordance with Table R402.1.3.

**Exception:** Deleted.

**R402.2.9.1 Slab-on-grade floor insulation installation.** Where installed, the insulation shall extend downward from the top of the slab on the outside or inside of the foundation wall. Insulation located below grade shall be extended the distance provided in Table R402.1.3 or the distance of the proposed design, as applicable, by any

combination of vertical insulation, insulation extending under the slab or insulation extending out from the building. Insulation extending away from the building shall be protected by pavement or by not less than 10 inches (254 mm) of soil. The top edge of the insulation installed between the exterior wall and the edge of the interior slab shall be permitted to be cut at a 45-degree (0.79 rad) angle away from the exterior wall. Slab edge insulation shall have a 2-inch termite inspection gap consistent with Appendix R2 of this code.

**R402.2.11 Closed crawl space walls.** Where the floor above a closed crawl space is not insulated, the exterior crawlspace walls shall be insulated in accordance with Table R402.1.2.

Wall insulation may be located in any combination of the outside and inside wall surfaces and within the structural cavities or materials of the wall system.

Wall insulation requires that the exterior wall band joist area of the floor frame be insulated. Wall insulation shall begin 3 inches (76.2 mm) below the top of the masonry foundation wall and shall extend down to 3 inches (76.2 mm) above the top of the footing or concrete floor, 3 inches (76.2 mm) above the interior ground surface or 24 inches (609.6 mm) below the outside finished ground level, whichever is less. (See Appendix R1.2.2 details).

Termite inspection, clearance, and wicking gaps are allowed in wall insulation systems. Insulation may be omitted in the gap area without energy penalty. The allowable insulation gap widths are listed in Table 402.2.11. If gap width exceeds the allowances, one of the following energy compliance options shall be met:

- 1 Wall insulation is not allowed and the required insulation value shall be provided in the floor system.
- 2 Compliance shall be demonstrated with energy trade-off methods provided by a North Carolina specific version of REScheck or the UA Alternative method or Section R405.

**R402.2.11 R402.2.10 Crawl space walls.** Crawl space walls shall be insulated in accordance with Table R402.1.3.

**Exception:** Crawl space walls associated with a crawl space that is vented to the outdoors and the floor overhead is insulated in accordance with Table R402.1.3 and Section R402.2.7.

**R402.2.10.1 Crawl space wall insulation installations.** Where crawl space wall insulation is installed, it shall be permanently fastened to the wall and shall extend downward from the floor to the finished grade elevation and then vertically or horizontally for not less than an additional 24 inches (610 mm). Exposed earth in unvented crawl space foundations shall be covered with a continuous Class I vapor retarder in accordance with the *International Building Code* or *International Residential Code*, as applicable. Joints of the vapor retarder shall overlap by 6 inches (153 mm) and be sealed or taped. The edges of the vapor retarder shall extend not less than 6 inches (153 mm) up stem walls and shall be attached to the stem walls.

Wall insulation may be located in any combination of the outside and inside wall surfaces and within the structural cavities or materials of the wall system. Wall insulation requires that the exterior wall band joist area of the floor frame be insulated. Wall insulation shall begin 3 inches (76.2 mm) below the top of the masonry foundation wall and shall extend down to 3 inches (76.2 mm) above the top of the footing or concrete floor, 3 inches (76.2 mm) above the interior ground surface or 24 inches (609.6 mm) below the outside finished ground level, whichever is less. (See Appendix R1.2.2 details).

Termite inspection, clearance, and wicking gaps are allowed in wall insulation systems. Insulation may be omitted in the gap area without energy penalty. The allowable insulation gap widths are listed in Table 402.2.10. If gap width exceeds the allowances, one of the following energy compliance options shall be met:

1. Wall insulation is not allowed and the required insulation value shall be provided in the floor system.
2. Compliance shall be demonstrated with energy trade-off methods provided by a North Carolina specific version of REScheck or the UA Alternative method or Section R401.2.2

TABLE R402.2.11 R402.2.10  
WALL INSULATION ALLOWANCES FOR TERMITE  
TREATMENT AND INSULATION GAPS

GAP WIDTH (inches)		INSULATION LOCATION	GAP DESCRIPTION
Minimum	Maximum		
2	3	Outside	Above grade inspection between top of insulation and bottom of siding
4	6	Outside	Below grade treatment

3 <sup>a</sup>	4 <sup>a</sup>	Inside	Wall inspection between top of insulation and bottom of sill
3 <sup>a</sup>	4 <sup>a</sup>	Inside	Clearance/wicking space between bottom of insulation and top of ground surface, footing, or concrete floor

a. No insulation shall be required on masonry walls of 9 inches in height or less.

**R402.2.12 R402.2.11 Masonry veneer.** Insulation shall not be required on the horizontal portion of a foundation that supports a masonry veneer.

**R402.2.13 R402.2.12 Sunroom and heated garage insulation.** *Sunrooms* enclosing *conditioned space* and *heated garages* shall meet the insulation requirements of this code.

**Exception:** For *sunrooms and heated garages provided with thermal isolation*, and enclosed *conditioned space*, the following exceptions to the insulation requirements of this code shall apply:

1. The minimum ceiling insulation *R*-values shall be R-19 in *Climate Zones 3 and 4* and R-24 in *Climate Zone 5*;
2. The minimum wall insulation *R*-value shall be R-13 in all *climate zones*. ~~New walls~~ Walls separating a *sunroom or heated garage* with *thermal isolation* from *conditioned space* shall comply with the *building thermal envelope* requirements of this code.

~~**R402.2.14 Framed cavity walls.** The exterior thermal envelope wall insulation shall be installed in contact and continuous alignment with the building envelope air barrier. Insulation shall be free from installation gaps, voids, or compression. For framed walls, the cavity insulation shall be enclosed on all sides with solid rigid material or Rim joists are not required to be enclosed on all sides. Wall insulation shall be enclosed at the following locations when installed on exterior walls prior to being covered by subsequent construction, consistent with the Appendix R1.2.3 of this code:~~

- ~~1. Tubs.~~
- ~~2. Showers.~~
- ~~3. Stairs.~~
4. Fireplace units (enclosed with rigid material only).

~~**R402.2.15 Attic knee walls.** Enclosure of wall cavity insulation also applies to walls that adjoin attic spaces by placing a rigid material or air barrier material on the attic space side of the wall on the attic space side of the wall consistent with the Appendix R1.2.3 of this code. Joints shall be air sealed. Noninsulating Class I vapor retarders, such as polyethylene, shall not be allowed.~~

**R402.3 Fenestration (Prescriptive).** In addition to the requirements of Section R402, fenestration shall comply with Sections R402.3.1 through R402.3.5.

**R402.3.1 U-factor.** An area-weighted average of fenestration products shall be permitted to satisfy the *U*-factor requirements.

**R402.3.2 Glazed fenestration SHGC.** An area-weighted average of fenestration products more than 50-percent glazed shall be permitted to satisfy the SHGC requirements.

Dynamic glazing shall be permitted to satisfy the SHGC requirements of Table R402.1.2 provided that the ratio of the higher to lower labeled SHGC is greater than or equal to 2.4, and the *dynamic glazing* is automatically controlled to modulate the amount of solar gain into the space in multiple steps. *Dynamic glazing* shall be considered separately from other fenestration, and area-weighted averaging with other fenestration that is not dynamic glazing shall be prohibited.

**Exception:** Dynamic glazing shall not be required to comply with this section where both the lower and higher labeled SHGC comply with the requirements of Table R402.1.2.

**R402.3.3 Glazed fenestration exemption.** ~~Either two glazed fenestration assemblies or up to 24 square feet (2.2 m<sup>2</sup>).~~ Not greater than 15 square feet (1.4 m<sup>2</sup>) of glazed fenestration per *dwelling unit* shall be exempt from the *U*-factor and SHGC requirements in Section R402.1.2. This exemption shall not apply to the Total UA alternative in Section R402.1.5.

~~**R402.3.4 Opaque door.** Opaque doors separating conditioned from unconditioned space shall have a maximum *U* factor of 0.35.~~

~~**Exception:** One side-hinged opaque door assembly is exempted from the *U*-factor requirement in Section R402.1.2. This exemption shall not apply to the *U*-factor alternative approach in Section R402.1.4 and the total UA alternative in Section R402.1.5.~~

~~**R402.3.4 Opaque door exemption.** One side-hinged opaque door assembly not greater than 24 square feet (2.22 m<sup>2</sup>) in area shall be exempt from the *U*-factor requirement in Section R402.1.2. This exemption shall not apply to the Total UA alternative in Section R402.1.5.~~

~~**R402.3.5 Sunroom fenestration.** Sunrooms enclosing conditioned space shall meet the fenestration requirements of this code.~~

~~**Exceptions:**~~

- ~~1. For sunrooms with thermal isolation and enclosing conditioned space in Climate Zones 3 through 5, the maximum fenestration *U*-factor shall be 0.40 and the maximum skylight *U*-factor shall be 0.75. Sunrooms with cooling systems shall have a maximum fenestration SHGC of 0.40 for all glazing.~~
- ~~2. A maximum of two glazed fenestration product assemblies having a *U*-factor no greater than 0.55 and, when cooling is provided, a SHGC no greater than 0.70 shall be permitted to be substituted for minimum code compliant fenestration product assemblies without penalty.~~

~~**R402.3.5 Sunroom and heated garage fenestration.** Sunrooms and heated garages enclosing conditioned space shall comply with the fenestration requirements of this code.~~

~~**Exception:** In Climate Zones 3 through 5 for sunrooms and heated garages with thermal isolation and enclosing conditioned space, the fenestration *U*-factor shall not exceed 0.45 and the skylight *U*-factor shall not exceed 0.70.~~

~~New fenestration separating the a sunroom or heated garage with thermal isolation from conditioned space shall comply with the building thermal envelope requirements of this code.~~

~~**R402.4 Air leakage control (Mandatory).** The building thermal envelope shall be constructed to limit air leakage in accordance with the requirements of Sections R402.4.1 through R402.4.6 R402.4.5.~~

~~**R402.4.1 Building thermal envelope.** The building thermal envelope shall be durably sealed to limit infiltration. The sealing methods between dissimilar materials shall allow for differential expansion and contraction. For all homes, where present, the following shall be caulked, gasketed, weatherstripped or otherwise sealed with an air barrier material, or solid material consistent with Appendix R1.2.4 of this code:~~

- ~~1 Blocking and sealing floor/ceiling systems and under-knee walls open to unconditioned or exterior space.~~
- ~~2. Capping and sealing shafts or chases, including flue shafts.~~
- ~~3. Capping and sealing soffit or dropped ceiling areas.~~
- ~~4. Sealing HVAC register boots and return boxes to subfloor or drywall.~~
- ~~5. Seal exterior house wrap material joints and seams per manufacturer's instructions or, if house wrap joints are not sealed, seal exterior sheathing and exposed band joist joints including perimeter joints and edges of these materials.~~

~~**Exceptions:**~~

- ~~1 Spray foam in building thermal envelope wall systems.~~
- ~~2 Wall sheathing joints where wall sheathing is fully glued to framing.~~

~~**R402.4.2 Air sealing.** Building envelope air tightness shall be demonstrated by compliance with Section R402.4.2.1 or R402.4.2.2. Appendix R3 contains optional sample worksheets for visual inspection or testing for the~~



permit holder's use only.

**R402.4.1 Building thermal envelope air leakage.** The *building thermal envelope* shall comply with Sections R402.4.1.1 through R402.4.1.3. The sealing methods between dissimilar materials shall allow for differential expansion and contraction.

**R402.4.1.1 Installation.** The components of the *building thermal envelope* as indicated in Table R402.4.1.1 shall be installed in accordance with the manufacturer's instructions and the criteria indicated in Table R402.4.1.1, as applicable to the method of construction. Where required by the *code official*, an *approved* third party shall inspect all components and verify compliance.

~~TABLE R402.4.2~~  
AIR BARRIER INSPECTION

COMPONENT	CRITERIA
Ceiling/attic	Sealants or gaskets provide a continuous air barrier system joining the top plate of framed walls with either the ceiling drywall or the top edge of wall drywall to prevent air leakage. Top plate penetrations are sealed. For ceiling finishes that are not air barrier systems such as tongue-and-groove planks, air barrier systems (for example, taped house wrap), shall be used above the finish. Note: It is acceptable that sealants or gaskets applied as part of the application of the drywall will not be observable by the code official.
Walls	Sill plate is gasketed or sealed to subfloor or slab.
Windows and doors	Space between window and exterior door jambs and framing is sealed.
Floors (including above garage and cantilevered floors)	The air barrier shall be installed at any exposed edge of insulation.
Penetrations	Utility penetrations through the building thermal envelope, including those for plumbing, electrical wiring, ductwork, security and fire alarm wiring, and control wiring, shall be sealed.
Garage separation	Air sealing is provided between the garage and conditioned spaces. An air barrier system shall be installed between the ceiling system above the garage and the ceiling system of interior spaces.
Ceiling penetrations	Ceiling electrical box penetrations and ceiling mechanical box penetrations shall be caulked, gasketed, or sealed at the penetration of the ceiling finish. See Appendix R1.2.4. Exception: Ceiling electrical boxes and ceiling mechanical boxes not penetrating the building thermal envelope.
Recessed lighting	Recessed light fixtures are air tight, IC-rated, and sealed to drywall. Exception: Fixtures in conditioned space.

TABLE R402.4.1.1  
AIR BARRIER, AIR SEALING AND INSULATION INSTALLATION<sup>a</sup>

COMPONENT	AIR BARRIER CRITERIA	INSULATION INSTALLATION CRITERIA
General requirements	A continuous air barrier shall be installed in the building envelope. Breaks or joints in the air barrier shall be sealed.	Air-permeable insulation shall not be used as a sealing material.
Ceiling/attic	The air barrier in any dropped ceiling or soffit shall be aligned with the insulation and any gaps in the air barrier shall be sealed. Access openings, drop down stairs or knee wall doors to unconditioned attic spaces shall be sealed.	The insulation in any dropped ceiling/soffit shall be aligned with the air barrier.

Walls	<p>The junction of the foundation and sill plate shall be sealed.</p> <p>The junction of the top plate and the top of exterior walls shall be sealed.</p> <p>Knee walls shall be sealed.</p>	<p>Cavities within corners and headers of frame walls shall be insulated by completely filling the cavity with a material having a thermal resistance, <i>R</i>-value, of not less than R-3 per inch. Exterior thermal envelope insulation for framed walls shall be installed in substantial contact and continuous alignment with the air barrier.</p>
Windows, skylights and doors	<p>The space between framing and skylights, and the jambs of windows and doors, shall be sealed.</p>	<p style="text-align: center;">=</p>
Rim joists	<p>Rim joists shall include an exterior air barrier.<sup>b</sup></p> <p>The junctions of the rim board to the sill plate and the rim board and the subfloor shall be air sealed.</p>	<p>Rim joists shall be insulated so that the insulation maintains permanent contact with the exterior rim board.<sup>b</sup></p>
Floors, including cantilevered floors and floors above garages	<p>The air barrier shall be installed at any exposed edge of insulation.</p>	<p>Floor framing cavity insulation shall be installed to maintain permanent contact with the underside of subfloor decking. Alternatively, floor framing cavity insulation shall be in contact with the top side of sheathing, or continuous insulation installed on the underside of floor framing and extending from the bottom to the top of all perimeter floor framing members.</p>
Basement crawl space and slab foundations	<p>Exposed earth in unvented crawl spaces shall be covered with a Class I vapor retarder/air barrier in accordance with Section R402.2.10.</p> <p>Penetrations through concrete foundation walls and slabs shall be air sealed.</p> <p>Class 1 vapor retarders shall not be used as an air barrier on below-grade walls and shall be installed in accordance with Section R702.7 of the <i>International Residential Code</i>.</p>	<p>Crawl space insulation, where provided instead of floor insulation, shall be installed in accordance with Section R402.2.10.</p> <p>Conditioned basement foundation wall insulation shall be installed in accordance with Section R402.2.8.1.</p> <p>Slab-on-grade floor insulation shall be installed in accordance with Section R402.2.10.</p>
Shafts, penetrations	<p>Duct and flue shafts and other similar penetrations to exterior or unconditioned space shall be sealed to allow for expansion, contraction and mechanical vibration.</p> <p>Utility penetrations of the air barrier shall be caulked, gasketed or otherwise sealed and shall allow for expansion, contraction of materials and mechanical vibration.</p>	<p>Insulation shall be fitted tightly around utilities passing through shafts and penetrations in the building thermal envelope to maintain required <i>R</i>-value.</p>
Narrow cavities	<p>Narrow cavities of 1 inch or less that are not able to be insulated shall be air sealed.</p>	<p>Batts to be installed in narrow cavities shall be cut to fit or narrow cavities shall be filled with insulation that on installation readily conforms to the available cavity space.</p>
Garage separation	<p>Air sealing shall be provided between the garage and conditioned spaces.</p>	<p>Insulated portions of the garage separation assembly shall be installed in accordance with Sections R303 and R402.2.7.</p>

**TABLE R402.4.1.1—continued**

**AIR BARRIER, AIR SEALING AND INSULATION INSTALLATION<sup>a</sup>**

COMPONENT	AIR BARRIER CRITERIA	INSULATION INSTALLATION CRITERIA
Recessed lighting	<p>Recessed light fixtures installed in the building thermal envelope shall be air sealed in accordance with Section R402.4.5.</p>	<p>Recessed light fixtures installed in the building thermal envelope shall be airtight and IC rated, and shall be buried or surrounded with insulation.</p>

<u>Plumbing, wiring or other obstructions</u>	<u>All holes created by wiring, plumbing or other obstructions in the air barrier assembly shall be air sealed.</u>	<u>Insulation shall be installed to fill the available space and surround wiring, plumbing, or other obstructions, unless the required R-value can be met by installing insulation and air barrier systems completely to the exterior side of the obstructions.</u>
<u>Shower/tub on exterior wall</u>	<u>The air barrier installed at exterior walls adjacent to showers and tubs shall separate the wall from the shower or tub.</u>	<u>Exterior walls adjacent to showers and tubs shall be insulated.</u>
<u>Electrical/phone box on exterior walls</u>	<u>The air barrier shall be installed behind electrical and communication boxes. Alternatively, air-sealed boxes shall be installed.</u>	==
<u>HVAC register boots</u>	<u>HVAC supply and return register boots that penetrate building thermal envelope shall be sealed to the sub-floor, wall covering or ceiling penetrated by the boot.</u>	==
<u>Concealed sprinklers</u>	<u>Where required to be sealed, concealed fire sprinklers shall only be sealed in a manner that is recommended by the manufacturer. Caulking or other adhesive sealants shall not be used to fill voids between fire sprinkler cover plates and walls or ceilings.</u>	==

- a. Inspection of log walls shall be in accordance with the provisions of ICC 400.
- b. Air barrier and insulation full enclosure is not required in unconditioned/ventilated attic spaces and at rim joists.

~~**R402.4.2.1 Visual inspection option.** Building envelope tightness shall be considered acceptable when items providing insulation enclosure in Section R402.2.14 and enclosure and air sealing in Section R402.2.15 and air sealing in Section R402.4.1 are addressed and when the items listed in Table R402.4.2, applicable to the method of construction, are certified by the builder, permit holder or registered design professional via the certificate in Appendix R1.1.~~

~~**R402.4.2.2 Testing option.** Building envelope tightness shall be considered acceptable when items providing insulation enclosure in Section R402.2.14 and enclosure and air sealing in Section R402.2.15 and air sealing in Section R402.4.1 are addressed and when tested air leakage is less than or equal to one of the two following performance measurements:~~

- ~~1-0.30 CFM50/Square Foot of Surface Area (SFSA); or~~
- ~~2- Five (5) air changes per hour (ACH50)~~

~~when tested with a blower door fan assembly, at a pressure of 33.5 psf (50 Pa). A single point depressurization test (not temperature corrected) is sufficient to comply with this provision, provided that the blower door fan assembly has been certified by the manufacturer to be capable of conducting tests in accordance with ASTM E779 or ASTM E1827. Testing shall occur after rough in and after installation of penetrations of the building envelope, including penetrations for utilities, plumbing, electrical, ventilation and combustion appliances. Testing shall be reported by the permit holder, a North Carolina licensed general contractor, a North Carolina licensed HVAC contractor, a North Carolina licensed home inspector, a registered design professional, a certified BPI Envelope Professional or a certified HERS rater.~~

~~During testing:~~

- ~~1 Exterior windows and doors, fireplace and stove doors shall be closed, but not sealed;~~
- ~~2 Dampers shall be closed, but not sealed, including exhaust, backdraft, and flue dampers;~~
- ~~3 Interior doors shall be open;~~
- ~~4 Exterior openings for continuous ventilation systems, air intake ducted to the return side of the conditioning system, and energy or heat recovery ventilators shall be closed and sealed;~~
- ~~5 Heating and cooling system(s) shall be turned off; and~~
- ~~6 Supply and return registers shall not be sealed.~~

~~The air leakage information, building air leakage result, tester name, date, and contact information, shall be included on the certificate described in Section R401.3.~~

~~For Test Criteria 1 above, the report shall be produced in the following manner: perform the blower door test and record the CFM50. Calculate the total square feet of surface area for the building thermal envelope (all floors, ceilings, and walls including windows and doors, bounding conditioned space) and record the area. Divide CFM50 by the total square feet and record the result. If the result is less than or equal to 0.30 CFM50/SFSA the envelope tightness is acceptable; or~~

~~For Test Criteria 2 above, the report shall be produced in the following manner: Perform a blower door test and record the CFM50. Multiply the CFM50 by 60 minutes to create CFHour50 and record. Then calculate the total conditioned volume of the home and record. Divide the CFH50 by the total volume and record the result. If the result is less than or equal to 5 ACH50, the envelope tightness is acceptable.~~

**R402.4.1.2 Testing.** The building or dwelling unit shall be tested for air leakage. The maximum air leakage rate for any building or dwelling unit under any compliance path shall not exceed 4.0 air changes per hour or 0.23 cubic feet per minute (CFM) per square foot [0.0079 m<sup>3</sup>/(s × m<sup>2</sup>)] of dwelling unit enclosure area. Testing shall be conducted in accordance with ANSI/RESNET/ICC 380, ASTM E779, ASTM E3158 or ASTM E1827 and reported at a pressure of 0.2 inch w.g. (50 Pascals). Alternately, if using a higher test pressure of 0.30 in. w.g.(75 Pa), a maximum air leakage rate of 0.30 cubic feet per minute per square foot of dwelling unit enclosure area shall be met. Where required by the code official, testing shall be conducted by an approved third party. A written report of the results of the test shall be signed by the party conducting the test and provided to the code official. Testing shall be performed at any time after creation of all penetrations of the building thermal envelope have been sealed.

**Exception:** For heated, attached private garages and heated, detached private garages accessory to one- and two-family dwellings and townhouses not more than three stories above grade plane in height, building envelope tightness and insulation installation shall be considered acceptable where the items in Table R402.4.1.1, applicable to the method of construction, are field verified. Where required by the code official, an approved third party independent from the installer shall inspect both air barrier and insulation installation criteria. Heated, attached private garage space and heated, detached private garage space shall be thermally isolated from all other habitable, conditioned spaces in accordance with Sections R402.2.12 and R402.3.5, as applicable.

During testing:

1. Exterior windows and doors, fireplace and stove doors shall be closed, but not sealed, beyond the intended weath-erstripping or other infiltration control measures.
2. Dampers including exhaust, intake, makeup air, backdraft and flue dampers shall be closed, but not sealed beyond intended infiltration control measures.
3. Interior doors, where installed at the time of the test, shall be open.
4. Exterior or interior terminations for continuous ventilation systems shall be sealed.
5. Heating and cooling systems, where installed at the time of the test, shall be turned off.
6. Supply and return registers, where installed at the time of the test, shall be fully open.

**Exceptions:**

1. When testing individual dwelling units, an air leakage rate not exceeding 0.30 cubic feet per minute per square foot [0.008 m<sup>3</sup>/(s × m<sup>2</sup>)] of the dwelling unit enclosure area, tested in accordance with ANSI/RESNET/ICC 380, ASTM E779 or ASTM E1827 and reported at a pressure of 0.2 inch w.g. (50 Pa), shall be an accepted alternative permitted in all climate zones for:
  - a. Attached single and multiple family building dwelling units.
  - b. Buildings or dwelling units that are 1,500 square feet (139.4 m<sup>2</sup>) or smaller.

2. For heated, attached private garages and heated, detached private garages accessory to one and two-family dwellings and townhouses not more than three stories above grade plane in height, building envelope tightness and insulation installation shall be considered acceptable where the items in Table R402.4.1.1, applicable to the method of construction, are field verified. Where required by the code official, an approved third party independent from the installer shall inspect both air barrier and insulation installation criteria. Heated, attached private garage space and heated, detached private garage space shall be thermally isolated from all other habitable, conditioned spaces in accordance with Sections R402.2.12 and R402.3.5, as applicable.

Mechanical ventilation shall be provided in accordance with Section M1505 of the *International Residential Code* or Section 403.3.2 of the *International Mechanical Code*, as applicable, or with other *approved* means of ventilation.

**R402.4.1.3 Leakage rate.** When complying with Section R401.2.1, the building or dwelling unit shall have an air leakage rate not exceeding 3.0 air changes per hour in Climate Zones 3 through 5, when tested in accordance with Section R402.4.1.2.

~~**R402.4.3 Fireplaces.** Site-built masonry fireplaces shall have flue dampers and comply with Section R1006 of the *North Carolina Residential Code* for combustion air.~~

**R402.4.2 Fireplaces.** New wood-burning fireplaces shall have tight-fitting flue dampers or doors, and outdoor combustion air. Where using tight-fitting doors on factory-built fireplaces *listed* and *labeled* in accordance with UL 127, the doors shall be tested and *listed* for the fireplace.

**R402.4.4 R402.4.3 Fenestration air leakage.** Windows, *skylights* and sliding glass doors shall have an air infiltration rate of not greater than 0.3 cfm per square foot (1.5 L/s/m<sup>2</sup>), and for swinging doors, not greater than 0.5 cfm per square foot (2.6 L/s/m<sup>2</sup>), when tested in accordance with NFRC 400 or AAMA/WDMA/CSA 101/I.S.2/A440 by an accredited, independent laboratory and *listed* and *labeled* by the manufacturer.

**Exception:** Field-fabricated Site-built windows, *skylights* and doors.

~~**R402.4.5 Rooms containing fuel burning appliances.** Deleted.~~

**R402.4.4 Rooms containing fuel burning appliances.** In Climate Zones 3 through 8, 5, where open combustion air ducts provide combustion air to open combustion fuel burning appliances, the appliances and combustion air opening shall be located outside the *building thermal envelope* or enclosed in a room that is isolated from inside the thermal envelope. Such rooms shall be sealed and insulated in accordance with the envelope requirements of Table R402.1.3, where the walls, floors and ceilings shall meet a minimum of the *basement wall R* value requirement. The door into the room shall be fully gasketed and any water lines and ducts in the room insulated in accordance with Section R403. The combustion air duct shall be insulated where it passes through *conditioned space* to an *R* value of not less than R-8.

**Exceptions:**

1. Direct vent appliances with both intake and exhaust pipes installed continuous to the outside.
2. Fireplaces and stoves complying with Section R402.4.2 and Section R1006 of the *International Residential Code*.

~~**R402.4.6 R402.4.5 R402.4.4 Recessed lighting.** Recessed luminaires installed in the *building thermal envelope* shall be sealed to limit air leakage between conditioned and *unconditioned spaces*. Recessed luminaires shall be IC-rated and *labeled* as having an air leakage rate of not greater than 2.0 cfm (0.944 L/s) when tested in accordance with ASTM E283 at a pressure differential of 1.57 psf (75 Pa). Recessed luminaires shall be sealed with a gasket or caulked between the housing and the interior wall or ceiling covering.~~

**R402.4.5 Electrical and communication outlet boxes (air-sealed boxes).** Electrical and communication outlet boxes installed in the building thermal envelope shall be sealed to limit air leakage between conditioned and unconditioned spaces. Electrical and communication outlet boxes shall be tested in accordance with NEMA OS 4, *Requirements for Air-Sealed Boxes for Electrical and Communication Applications*, and shall have an air leakage rate of not greater than 2.0 cubic feet per minute (0.944 L/s) at a pressure differential of 1.57 psf (75 Pa). Electrical and communication outlet boxes shall be marked “NEMA OS 4” or “OS 4” in accordance with NEMA OS 4. Electrical and communication outlet boxes shall be installed per the manufacturer’s instructions and with any supplied components required to achieve compliance with NEMA OS 4.

**R402.5 Maximum fenestration U-factor and SHGC (Mandatory).** The area-weighted average maximum fenestration *U*-factor permitted using trade-offs from Section R402.1.5 shall be 0.48. Maximum skylight *U*-factors shall be 0.65 in Climate Zones 4 and 5 and 0.60 in Climate Zone 3. The area-weighted average maximum fenestration SHGC permitted using trade-offs from Section R405 in Climate Zone 3 shall be 0.50.

**Exception:** A maximum of two glazed fenestration product assemblies having a *U*-factor no greater than 0.55 and a SHGC no greater than 0.70 shall be permitted to be substituted for minimum code compliant fenestration product assemblies without penalty.

**R402.5 Maximum fenestration U-factor and SHGC.** The area-weighted average maximum fenestration *U*-factor permitted using tradeoffs from Section R402.1.5 or R405 shall be 0.48 in Climate Zones 4 and 5 for vertical fenestration, and 0.75 in Climate Zones 4 through 5 for skylights. The area-weighted average maximum fenestration SHGC permitted using tradeoffs from Section R405 in *Climate Zone 3* shall be **0.40**.

**Exception:** The maximum *U*-factor and solar heat gain coefficient (SHGC) for fenestration shall not be required in storm shelters complying with ICC 500.

## SECTION R403 SYSTEMS

**R403.1 Controls (Mandatory).** Not less than one thermostat shall be provided for each separate heating and cooling system.

**R403.1.1 Programmable thermostat.** ~~When the primary heating system is a forced air furnace or heat pump, The thermostat controlling the primary heating or cooling system of the *dwelling unit* shall be capable of controlling the heating and cooling system on a daily schedule to maintain different temperature set points at different times of day and different days of the week. This thermostat shall include the capability to set back or temporarily operate the system to maintain *zone* temperatures of not less than 55°F (13°C) to not greater than 85°F (29°C). The thermostat shall be programmed initially by the manufacturer with a heating temperature setpoint of not greater than 70°F (21°C) and a cooling temperature setpoint of not less than 78°F (26°C).~~

**R403.1.2 Heat pump supplementary heat (Mandatory).** Heat pumps having supplementary electric-resistance heat shall have controls that, except during defrost, prevent supplemental heat operation when the heat pump compressor can meet the heating load.

~~A heat strip outdoor temperature lockout thermostat shall be provided to prevent supplemental heat operation in response to the thermostat being changed to a warmer setting. The lockout shall be set no lower than 35°F (2°C) and no higher than 40°F (4°C).~~

### **Exceptions:**

~~1. In lieu of a heat strip outdoor temperature lockout thermostat, the following time and temperature electric resistance control may be used. After 6 minutes of compressor run time in heat mode, supplemental electric heat shall energize only if the leaving air temperature from the indoor coil is below 90°F (32°C). If the indoor coil leaving air temperature exceeds 100°F (38°C), supplemental heat shall automatically de-energize, but allow the compressor to continue to operate until the call is satisfied. No thermostat shall initiate supplemental electric heat at any time. Thermostat controlled emergency heat shall not be limited by outdoor temperature. Electric resistance supplemental heat during defrost shall operate normally without limitation.~~

~~2. In lieu of a heat strip outdoor temperature lockout thermostat, a programmable indoor thermostat with the capability to minimize the use of supplementary electrical resistance heat using an automatic temperature ramp up control feature shall be acceptable.~~

**R403.2 Hot water boiler outdoor temperature setback.** Hot water boilers that supply heat to the building through one or two pipe heating systems shall have an outdoor setback control that lowers the boiler water temperature based on the outdoor temperature.

**R403.2 Hot water boiler temperature reset.** The manufacturer shall equip each gas, oil and electric boiler (other than a boiler equipped with a tankless domestic water heating coil) with automatic means of adjusting the water temperature supplied by the boiler to ensure incremental change of the inferred heat load will cause an incremental change in the temperature of the water supplied by the boiler. This can be accomplished with outdoor reset, indoor reset or water temperature sensing.

**R403.3 Ducts.** Ducts and air handlers shall be installed in accordance with Sections R403.3.1 through ~~R403.3.4~~ R403.3.7.

**R403.3.1 Insulation (Mandatory).** ~~Supply and return ducts in unconditioned space and outdoors shall be insulated to a minimum R-8. Supply ducts inside semi-conditioned space shall be insulated to a minimum R-4; return ducts inside conditioned and semi-conditioned space are not required to be insulated. Ducts located inside conditioned space are not required to be insulated other than as may be necessary for preventing the formation of condensation on the exterior of cooling ducts~~

**R403.3.1 Ducts located outside conditioned space.** Supply and return ducts located outside *conditioned space* shall be insulated to an *R*-value of not less than R-8 for ducts 3 inches (76 mm) in diameter and larger and not less than R-6 for ducts smaller than 3 inches (76 mm) in diameter. Ducts buried beneath a building shall be insulated as required per this section or have an equivalent thermal distribution efficiency. Underground ducts utilizing the thermal distribution efficiency method shall be listed and *labeled* to indicate the *R*-value equivalency.

**R403.3.2 Ducts located in conditioned space.** For ductwork to be considered inside a *conditioned space*, it shall comply with one of the following:

1. The duct system shall be located completely within the *continuous air barrier* and within the building thermal envelope.
2. Ductwork in ventilated attic spaces shall be buried within ceiling insulation in accordance with Section R403.3.3 and all of the following conditions shall exist:
  - 2.1. The air handler is located completely within the *continuous air barrier* and within the *building thermal envelope*.
  - 2.2. The duct leakage, as measured either by a rough-in test of the ducts or a post-construction total system leakage test to outside the *building thermal envelope* in accordance with Section R403.3.6, is less than or equal to 1.5 cubic feet per minute (42.5 L/min) per 100 square feet (9.29 m<sup>2</sup>) of *conditioned floor area* served by the duct system.
  - 2.3. The ceiling insulation *R*-value installed against and above the insulated duct is greater than or equal to the proposed ceiling insulation *R*-value, less the *R*-value of the insulation on the duct.
3. Ductwork in floor cavities located over unconditioned space shall comply with all of the following:
  - 3.1. A *continuous air barrier* installed between unconditioned space and the duct.
  - 3.2. Insulation installed in accordance with Section R402.2.7.
  - 3.3. A minimum R-19 insulation installed in the cavity width separating the duct from unconditioned space.
4. Ductwork located within *exterior walls* of the *building thermal envelope* shall comply with the following:
  - 4.1. A *continuous air barrier* installed between unconditioned space and the duct.
  - 4.2. Minimum R-10 insulation installed in the cavity width separating the duct from the outside sheathing.
  - 4.3. The remainder of the cavity insulation shall be fully insulated to the drywall side.

**R403.3.3 Ducts buried within ceiling insulation.** Where supply and return air ducts are partially or completely buried in ceiling insulation, such ducts shall comply with all of the following:

1. The supply and return ducts shall have an insulation *R*-value not less than R-8.

2. In Zones 4 and 5, at all points along each duct, the sum of the ceiling insulation R-value against and above the top of the duct, and against and below the bottom of the duct, shall be not less than R-19, excluding the R-value of the duct insulation.
3. In Climate Zone 3, the supply ducts shall be completely buried within ceiling insulation, insulated to an R-value of not less than R-13 and in compliance with the vapor retarder requirements of Section 604.11 of the *International Mechanical Code* or Section M1601.4.6 of the *International Residential Code*, as applicable.

**Exception:** Sections of the supply duct that are less than 3 feet (914 mm) from the supply outlet shall not be required to comply with these requirements.

**R403.3.3.1 Effective R-value of deeply buried ducts.** Where using the Total Building Performance Compliance Option in accordance with Section R401.2.2, sections of ducts that are installed in accordance with Section R403.3.3, located directly on or within 5.5 inches (140 mm) of the ceiling, surrounded with blown-in attic insulation having an R-value of R-30 or greater and located such that the top of the duct is not less than 3.5 inches (89 mm) below the top of the insulation, shall be considered as having an effective duct insulation R-value of R-25.

**R403.3.2 R403.3.4 Sealing (Mandatory).** Ducts, air handlers and filter boxes ~~and building cavities used as ducts~~, shall be sealed. Joints and seams shall comply with either the *International Mechanical Code* or *International Residential Code*, as applicable.

**Exceptions:**

1. ~~Air impermeable spray foam products shall be permitted to be applied without additional joint seals.~~
2. ~~Deleted.~~

**R403.3.4.1 Sealed air handler.** Air handlers shall have a manufacturer's designation for an air leakage of not greater than 2 percent of the design airflow rate when tested in accordance with ASHRAE 193.

**R403.3.3 Duct leakage (Prescriptive) and duct testing (Mandatory).** Duct testing and duct leakage shall be verified by compliance with either Section R403.3.3.1 or R403.3.3.2. Duct testing shall be performed and reported by the permit holder, a North Carolina licensed general contractor, a North Carolina licensed HVAC contractor, a North Carolina licensed Home Inspector, a registered design professional, a certified BPI Envelope Professional or a certified HERS rater. A single point depressurization, not temperature corrected, test is sufficient to comply with this provision, provided that the duct testing fan assembly(s) has been certified by the manufacturer to be capable of conducting tests in accordance with ASTM E1554—07.

The duct leakage information, including duct leakage test selected and the result, tester name, date, and contact information, shall be included on the certificate described in Section R401.3.

For the test criteria, the report shall be produced in the following manner: perform the HVAC system air leakage test and record the CFM25. Calculate the total square feet of Conditioned Floor Area (CFA) served by that system. Multiply CFM25 by 100, divide the result by the CFA and record the result. If the result is less than or equal to 5 CFM25/100SF for the "Total duct leakage" test or less than or equal to 4 CFM25/100SF for the "Duct leakage to the outside" test, then the HVAC system air tightness is acceptable. Appendix R3C contains optional sample worksheets for duct testing for the permit holder's use only.

**Exceptions to testing requirements:**

1. ~~Duct systems or portions thereof inside the building thermal envelope shall not be required to be leak tested.~~
2. ~~Installation of a partial system as part of replacement, renovation or addition does not require a duct leakage test.~~
3. ~~Duct systems (complete) serving areas of 750 square feet or less shall not need to be required to be leak tested.~~

**R403.3.3.1 Total duct leakage.** Total duct leakage shall be less than or equal to 5 cfm (141.6 L/min) per 100 square feet (9.29 m<sup>2</sup>) of conditioned floor area served by that system when tested at a pressure differential of 0.1 inches w.g. (25 Pa) across the entire system, including the manufacturer's air handler enclosure. During testing:

1. ~~Block, if present, ventilation air duct(s) connected to the conditioning system.~~
2. ~~The duct air leakage testing equipment shall be attached to the largest return in the system or to the air handler.~~
3. ~~The filter shall be removed and the air handler power shall be turned off.~~



4. ~~Supply boots or registers and return boxes or grilles shall be taped, plugged, or otherwise sealed air tight.~~
5. ~~The hose for measuring the 25 Pascals of pressure differential shall be inserted into the boot of the supply that is nominally closest to the air handler.~~
6. ~~Specific instructions from the duct testing equipment manufacturer shall be followed to reach duct test pressure and measure duct air leakage.~~

~~**R403.3.3.2 Duct leakage to the outside.** Conduct the test using fan pressurization of distribution system and building at a fixed reference pressure for combined supply and return leak. Duct leakage to the outside shall be less than or equal to 4 cfm (113.3 L/min) per 100 square feet (9.29 m<sup>2</sup>) of conditioned floor area served by that system when tested at a pressure differential of 0.1 inches w.g. (25 Pa) across the entire system, relative to the outside, including the manufacturer's air handler enclosure.~~

During testing:

1. Block, if present, the ventilation air duct(s) connected to the conditioning system.
2. The duct air leakage testing equipment shall be attached to the largest return in the system or to the air handler.
3. The filter shall be removed and the air handler power shall be turned off.
4. Supply boots or registers and return boxes or grilles shall be taped, plugged, or otherwise sealed air tight or as tight as possible.
5. The hose for measuring the 25 Pascals of pressure differential shall be inserted into the boot of the supply that is nominally closest to the air handler.
6. Open all interconnecting doors in the building, close dampers for fireplaces and other operable dampers.
7. Set up an envelope air moving/flow-regulating/flow measurement assembly, such as a blower door, following the manufacturer's prescribed procedure.
8. ~~Specific instructions from the duct testing equipment manufacturer shall be followed to reach duct test pressure and measure duct air leakage used in combination with a blower door. Typical steps are as follows:~~
  - a. ~~Depressurize the ductwork system to 25 Pa using the measurement hose in Step 5 above.~~
  - b. ~~Depressurize the house to 25 Pa using an envelope air moving/flow regulating/flow measurement assembly, such as a blower door.~~
  - c. ~~Correct the duct pressure to measure 0 Pa of pressure differential between the house and the ductwork system.~~
  - d. ~~Read the cfm of duct leakage using the procedures for the specific equipment being used. (Note that most automatically calculating pressure gauges cannot compute the CFM25 automatically with a duct to house difference in pressure of 0 Pa, so the gauge setting should be set to read CFM instead of CFM25).~~

**R403.3.5 Duct testing.** Ducts shall be pressure tested in accordance with ANSI/RESNET/ICC 380 or ASTM E1554 to determine air leakage by one of the following methods:

1. Rough-in test: Total leakage shall be measured with a pressure differential of 0.1 inch w.g. (25 Pa) across the system, including the manufacturer's air handler enclosure if installed at the time of the test. Registers shall be taped or otherwise sealed during the test.
2. Postconstruction test: Total leakage shall be measured with a pressure differential of 0.1 inch w.g. (25 Pa) across the entire system, including the manufacturer's air handler enclosure. Registers shall be taped or otherwise sealed during the test.

**Exception:** A duct air-leakage test shall not be required for ducts serving heating, cooling or ventilation systems that are not integrated with ducts serving heating or cooling systems.

**R403.3.6 Duct leakage.** The total leakage of the ducts, where measured in accordance with Section R403.3.5, shall be as follows:

Duct testing shall be performed and reported by the permit holder, a North Carolina licensed general contractor, a North Carolina licensed HVAC contractor, a North Carolina licensed Home Inspector, a registered design professional, a certified BPI Envelope Professional, a certified HERS rater, or other certified rater.

1. Rough-in test: The total leakage shall be less than or equal to 4.0 cubic feet per minute (113.3 L/min) per 100 square feet (9.29 m<sup>2</sup>) of conditioned floor area where the air handler is installed at the time of the test. Where the air handler is not installed at the time of the test, the total leakage shall be less than or equal to 3.0 cubic feet per minute (85 L/min) per 100 square feet (9.29 m<sup>2</sup>) of conditioned floor area.
2. Postconstruction test: Total leakage shall be less than or equal to 4.0 cubic feet per minute (113.3 L/min) per 100 square feet (9.29 m<sup>2</sup>) of conditioned floor area.
3. Test for ducts within thermal envelope: Where all ducts and air handlers are located entirely within the building thermal envelope, total leakage shall be less than or equal to 8.0 cubic feet per minute (226.6 L/min) per 100 square feet (9.29 m<sup>2</sup>) of conditioned floor area.

**R403.3.4 Building cavities (Mandatory).** Building framing cavities shall not be used as supply ducts or supply plenums.

**R403.3.7 Building cavities.** Building framing cavities shall not be used as ducts or plenums.

**R403.4 Mechanical system piping insulation (Mandatory).** Mechanical system piping capable of carrying fluids greater than 105°F (41°C) or less than 55°F (13°C) shall be insulated to an R-value of not less than R-3.

**R403.4.1 Protection of piping insulation.** Piping insulation exposed to weather shall be protected from damage, including that caused by sunlight, moisture, equipment maintenance and wind. The protection shall provide shielding from solar radiation that can cause degradation of the material. Adhesive tape shall be prohibited.

~~**R403.5 Service hot water systems.** All circulating service hot water piping shall be insulated to at least R-2. Circulating hot water systems shall include an automatic or readily accessible manual switch that can turn off the hot water circulating pump when the system is not in use.~~

**R403.5 Service hot water systems.** Energy conservation measures for service hot water systems shall be in accordance with Sections R403.5.1 through R403.5.3.

**R403.5.1 Heated water circulation and temperature maintenance systems.** Heated water circulation systems shall be in accordance with Section R403.5.1.1. Heat trace temperature maintenance systems shall be in accordance with Section R403.5.1.2. Automatic controls, temperature sensors and pumps shall be in a location with access. Manual controls shall be in a location with ready access.

**R403.5.1.1 Circulation systems.** Heated water circulation systems shall be provided with a circulation pump. The system return pipe shall be a dedicated return pipe or a cold water supply pipe. Gravity and thermosyphon circulation systems shall be prohibited. Controls for circulating hot water system pumps shall automatically turn off the pump when the water in the

circulation loop is at the desired temperature and when there is no demand for hot water. The controls shall limit the temperature of the water entering the cold water piping to not greater than 104°F (40°C).

**R403.5.1.1.1 Demand recirculation water systems.** Where installed, *demand recirculation water systems* shall have controls that start the pump upon receiving a signal from the action of a user of a fixture or appliance, sensing the presence of a user of a fixture or sensing the flow of hot or tempered water to a fixture fitting or appliance.

**R403.5.1.2 Heat trace systems.** Electric heat trace systems shall comply with IEEE 515.1 or UL 515. Controls for such systems shall automatically adjust the energy input to the heat tracing to maintain the desired water temperature in the piping in accordance with the times when heated water is used in the occupancy.

**R403.5.2 Hot water pipe insulation.** Insulation for service hot water piping with a thermal resistance, *R*-value, of not less than R-3 shall be applied to the following:

1. Piping  $\frac{3}{4}$  inch (19.1 mm) and larger in nominal diameter located inside the conditioned space.
2. Piping serving more than one dwelling unit.
3. Piping located outside the conditioned space.
4. Piping from the water heater to a distribution manifold.
5. Piping located under a floor slab.
6. Buried piping.
7. Supply and return piping in circulation and recirculation systems other than cold water pipe return demand recirculation systems.

**R403.5.3 Drain water heat recovery units.** Where installed, drain water heat recovery units shall comply with CSA B55.2. Drain water heat recovery units shall be tested in accordance with CSA B55.1. Potable water-side pressure loss of drain water heat recovery units shall be less than 3 psi (20.7 kPa) for individual units connected to one or two showers. Potable water-side pressure loss of drain water heat recovery units shall be less than 2 psi (13.8 kPa) for individual units connected to three or more showers.

**R403.6 Mechanical ventilation (Mandatory).** As applicable, *Buildings* buildings and *dwelling units* shall be provided with mechanical ventilation that complies with the requirements of the *International Residential Code* or *International Mechanical Code*, as applicable, or with other approved means of ventilation. Outdoor air intakes and exhausts shall have automatic or gravity dampers that close when the ventilation system is not operating.

**R403.6.1 Heat or energy recovery ventilation.** Deleted.

**R403.6.2 Whole-dwelling mechanical ventilation system fan efficacy.** Fans used to provide whole-dwelling mechanical ventilation shall meet the efficacy requirements of Table R403.6.2 at one or more rating points. Fans shall be tested in accordance with HVI 916 and listed. The airflow shall be reported in the product listing or on the label. Fan efficacy shall be reported in the product listing or shall be derived from the input power and airflow values reported in the product listing or on the label. Fan efficacy for fully ducted HRV, ERC, balanced, and in-line fans shall be determined at a static pressure of not less than 0.2 inch w.c. (49.85 Pa). Fan efficacy for ducted range hoods, bathroom and utility room fans shall be determined at a static pressure of not less than 0.1 inch w.c. (24.91 Pa). □

**TABLE R403.6.2**  
**WHOLE-DWELLING MECHANICAL VENTILATION**  
**SYSTEM FAN EFFICACY<sup>a</sup>**

FAN LOCATION	AIRFLOW RATE MINIMUM (CFM)	MINIMUM EFFICACY (CFM/WATT)
HRV, ERV □	Any	1.2 cfm/watt
In-line supply or exhaust fan	Any	3.8 cfm/watt
Other exhaust fan	< 90	2.8 cfm/watt

Other exhaust fan	<u>&gt; 90</u>	<u>3.5 cfm/watt</u>
<u>Air-handler that is integrated to tested and listed HVAC equipment</u>	<u>Any</u>	<u>1.2 cfm/watt</u>

For SI: 1 cubic foot per minute = 28.3 L/min.

a. Design outdoor airflow rate/watts of fan used.

**R403.6.3 Testing.** Mechanical ventilation systems shall be tested and verified to provide the minimum ventilation flow rates required by Section R403.6. Testing shall be performed according to the ventilation equipment manufacturer's instructions, or by using a flow hood or box, flow grid, or other airflow measuring device at the mechanical ventilation fan's inlet terminals or grilles, outlet terminals or grilles, or in the connected ventilation ducts. Where required by the code official, testing shall be conducted by an approved third party. A written report of the results of the test shall be signed by the party conducting the test and provided to the code official.

**Exception:** Kitchen range hoods that are ducted to the outside with 6-inch (152 mm) or larger duct and not more than one 90-degree (1.57 rad) elbow or equivalent in the duct run.

**R403.7 Equipment sizing and efficiency rating.** ~~Heating and cooling equipment shall be sized in accordance with the North Carolina Mechanical Code or the North Carolina Residential Code~~ Heating and cooling equipment shall be sized in accordance with ACCA Manual S based on building loads calculated in accordance with ACCA Manual J or other approved heating and cooling calculation methodologies. New or replacement heating and cooling equipment shall have an efficiency rating equal to or greater than the minimum required by federal law for the geographic location where the equipment is installed.

**R403.8 Systems serving multiple dwelling units (Mandatory).** ~~Building mechanical systems and service water heating Systems.~~ Systems serving multiple dwelling units shall comply with Sections C403 and C404 of the International Energy Conservation Code—Commercial Provisions instead of Section R403.

**R403.9 Snow melt and ice system controls (Mandatory).** ~~Snow- and ice-melting systems, supplied through energy service to the building, shall include automatic controls capable of shutting off the system when the pavement temperature is greater than 50°F (10°C) and precipitation is not falling, and an automatic or manual control that will allow shutoff when the outdoor temperature is greater than 40°F (4.8°C).~~

**R403.10 Pools and permanent spa energy consumption (Mandatory).** ~~Energy consumption of pools and spas.~~ Energy consumption of pools and spas. The energy consumption of pools and permanent spas shall be controlled by the requirements in Sections R403.10.1 through R403.10.3.

**R403.10.1 Heaters.** ~~All heaters shall be equipped with a readily accessible on-off switch that is mounted outside of the heater to allow shutting off the heater without adjusting the thermostat setting. Gas-fired heaters shall not be equipped with constant burning pilot lights.~~

**R403.10.1 Heaters.** The electric power to heaters shall be controlled by an on-off switch that is an integral part of the heater mounted on the exterior of the heater in a location with ready access, or external to and within 3 feet (914 mm) of the heater. Operation of such switch shall not change the setting of the heater thermostat. Such switches shall be in addition to a circuit breaker for the power to the heater. Gas-fired heaters shall not be equipped with continuously burning ignition pilots.

**R403.10.2 Time switches.** Time switches or other control methods that can automatically turn heaters and pump motors off and on according to a preset schedule shall be installed for heaters and pump motors. Heaters and pump motors that have built-in time switches shall be in compliance with this section.

**Exceptions:**

1. Where public health standards require 24-hour pump operation.
2. Pumps that operate solar- and waste-heat-recovery pool heating systems.

**R403.10.3 Covers.** Outdoor heated pools and outdoor permanent spas shall be provided with a Class I vapor-retardant cover or other approved vapor-retardant means.

**Exception:** Pools deriving over 70 percent of the energy from heating from *site-recovered energy or solar energy source*.

**Exception:** Where more than 75 percent of the energy for heating, computed over an operation season of not fewer than 3 calendar months, is from a heat pump or an on-site renewable energy system, covers or other vapor-retardant means shall not be required.

**R403.11 Portable spas (Mandatory).** ~~Deleted.~~

**R403.11 Portable spas.** The energy consumption of electric-powered portable spas shall be controlled by the requirements of APSP 14.

**R403.12 Residential pools and permanent residential spas.** Residential swimming pools and permanent residential spas that are accessory to detached one- and two-family dwellings and townhouses three stories or less in height above grade plane and that are available only to the household and its guests shall be in accordance with APSP 15.

**R403.12 Residential pools and permanent residential spas.** Where installed, the energy consumption of residential swimming pools and permanent residential spas shall be controlled in accordance with the requirements of APSP 15.

## SECTION R404 ELECTRICAL POWER AND LIGHTING SYSTEMS

**R404.1 Lighting equipment (Mandatory).** Not less than 75 percent of the lamps in permanently installed lighting fixtures shall be high-efficacy lamps or not less than 75 percent of the permanently installed lighting fixtures shall contain only high-efficacy lamps.

**Exception:** Low-voltage lighting

**R404.1 Lighting equipment.** All permanently installed lighting fixtures, excluding kitchen appliance lighting fixtures, shall contain only *high-efficacy light sources*.

**R404.1.1 Exterior lighting.** Connected exterior lighting for residential buildings shall comply with Section C405.4.

### **Exceptions:**

1. Detached one- and two- family dwellings.
2. Townhouses.
3. Solar-powered lamps not connected to any electrical service.
4. Luminaires controlled by a motion sensor.
5. Lamps and luminaires that comply with Section R404.1.

**R404.1.1 Lighting equipment (Mandatory)R404.1.2 Fuel gas lighting equipment.** Fuel gas lighting systems shall not have continuously burning pilot lights.

**R404.2 Interior lighting controls.** Permanently installed lighting fixtures shall be controlled with either a dimmer, an occupant sensor control or other control that is installed or built into the fixture.

**Exception:** Lighting controls shall not be required for the following:

1. Bathrooms.
2. Hallways.
3. Exterior lighting fixtures.
4. Lighting designed for safety or security.

**R404.3 Exterior lighting controls.** Where the total permanently installed exterior lighting power is greater than 30 watts, the permanently installed exterior lighting shall comply with the following:

1. Lighting shall be controlled by a manual on and off switch which permits automatic shut-off actions.

**Exception:** Lighting serving multiple *dwelling units*.

2. Lighting shall be automatically shut off when daylight is present and satisfies the lighting needs.

3. Controls that override automatic shut-off actions shall not be allowed unless the override automatically returns automatic control to its normal operation within 24 hours.

SECTION R405

**SIMULATED PERFORMANCE ALTERNATIVE (PERFORMANCE) TOTAL BUILDING PERFORMANCE**

**R405.1 Scope.** This section establishes criteria for compliance using ~~simulated energy~~ total building performance analysis. Such analysis shall include ~~those items identified in Table R405.5.2(1), as applicable. A North Carolina registered design professional is required to perform the analysis if required by North Carolina licensure laws.~~ heating, cooling, mechanical ventilation and service water-heating energy only.

**R405.2 Mandatory requirements.** ~~Compliance with this section requires that the mandatory provisions identified in Section R401.2(2) be met.~~

**R405.3 Performance based compliance.** ~~Compliance based on simulated energy performance requires that a proposed residence (*proposed design*) be shown to have an annual energy cost that is less than or equal to the annual energy cost of the *standard reference design*. Energy prices shall be taken from a source *approved by the code official*, such as the Department of Energy, Energy Information Administration’s *State Energy Price and Expenditure Report*. *Code officials* shall be permitted to require time of use pricing in energy cost calculations.~~

**R405.3 R405.2 Performance-based compliance.** Compliance based on total building performance requires that a *proposed design* meets all of the following:

1. The requirements of the sections indicated within Table R405.2.
2. The building thermal envelope greater than or equal to levels of efficiency and solar heat gain coefficients in Table R402.1.1 or R402.1.3 of the 2009 *International Energy Conservation Code*.
3. An annual energy cost that is less than or equal to the annual energy cost of the *standard reference design*. Energy prices shall be taken from a source *approved by the code official*, such as the Department of Energy, Energy Information Administration’s *State Energy Data System Prices and Expenditures reports*. *Code officials* shall be permitted to require time-of-use pricing in energy cost calculations.

**Exception:** The energy use based on source energy expressed in Btu or Btu per square foot of conditioned floor area shall be permitted to be substituted for the energy cost. The source energy multiplier for electricity shall be 3.16. The source energy multiplier for fuels other than electricity shall be 1.1.

**R405.4 R405.3 Documentation.** Documentation of the software used for the performance design and the parameters for the *building* shall be in accordance with Sections ~~R405.4.1 R405.3.1~~ through ~~R405.4.3 R405.3.2.2~~.

**R405.4.1 R405.3.1 Compliance software tools.** Documentation verifying that the methods and accuracy of the compliance software tools conform to the provisions of this section shall be provided to the *code official*.

**R405.4.2 R405.3.2 Compliance report.** Compliance software tools shall generate a report that documents that the *proposed design* complies with Section R405.3. A compliance report on the *proposed design* shall be submitted with the application for the building permit. Upon completion of the building, a confirmed compliance report based on the confirmed condition of the building shall be submitted to the *code official* before a certificate of occupancy is issued.

Compliance reports shall include information in accordance with Sections R405.3.1 and R405.3.2.2.

**TABLE R405.2  
REQUIREMENTS FOR TOTAL BUILDING PERFORMANCE**

<u>SECTION<sup>a</sup></u>	<u>TITLE</u>
----------------------------	--------------

<b>General</b>	
<u>R401.2.5</u>	<u>Additional energy efficiency</u>
<u>R401.3</u>	<u>Certificate</u>
<b>Building Thermal Envelope</b>	
<u>R402.1.1</u>	<u>Vapor retarder</u>
<u>R402.2.3</u>	<u>Eave baffle</u>
<u>R402.2.4.1</u>	<u>Access hatches and doors</u>
<u>R402.2.10.1</u>	<u>Crawl space wall insulation installations</u>
<u>R402.4.1.1</u>	<u>Installation</u>
<u>R402.4.1.2</u>	<u>Testing</u>
<u>R402.5</u>	<u>Maximum fenestration U-factor and SHGC</u>
<b>Mechanical</b>	
<u>R403.1</u>	<u>Controls</u>
<u>R403.3, including R403.3.1, except Sections R403.3.2, R403.3.3 and R403.3.6</u>	<u>Ducts</u>
<u>R403.4</u>	<u>Mechanical system piping insulation</u>
<u>R403.5.1</u>	<u>Heated water circulation and temperature maintenance systems</u>
<u>R403.5.3</u>	<u>Drain water heat recovery units</u>
<u>R403.6</u>	<u>Mechanical ventilation</u>
<u>R403.7</u>	<u>Equipment sizing and efficiency rating</u>
<u>R403.8</u>	<u>Systems serving multiple dwelling units</u>
<u>R403.9</u>	<u>Snow melt and ice systems</u>
<u>R403.10</u>	<u>Energy consumption of pools and spas</u>
<u>R403.11</u>	<u>Portable spas</u>
<u>R403.12</u>	<u>Residential pools and permanent residential spas</u>
<b>Electrical Power and Lighting Systems</b>	
<u>R404.1</u>	<u>Lighting equipment</u>
<u>404.2</u>	<u>Interior lighting controls</u>

a. Reference to a code section includes all the relative subsections except as indicated in the table.

**R405.4.2 Compliance report.** Compliance software tools shall generate a report that documents that the *proposed*

~~design complies with Section R405.3. A compliance report on the *proposed design* shall be submitted. A compliance report shall include the following:~~

- ~~1. Building street address, or other building site identification.~~
- ~~2. A statement indicating that the *proposed design* complies with Section R405.3.~~
- ~~3. An inspection checklist documenting the building component characteristics of the *proposed design* as indicated in Table R405.5.2(1). The inspection checklist shall show results for both the *standard reference design* and the *proposed design* with user inputs to the compliance software to generate the results.~~
- ~~4. A site-specific energy analysis report that is in compliance with Section R405.3.~~

**R405.3.2.1 Compliance report for permit application.** A compliance report submitted with the application for building permit shall include the following:

1. Building street address, or other *building site* identification.
2. The name of the individual performing the analysis and generating the compliance report.
3. The name and version of the compliance software tool.
4. Documentation of all inputs entered into the software used to produce the results for the reference design and/or the rated home.
5. A certificate indicating that the proposed design complies with Section R405.3. The certificate shall document the building components' energy specifications that are included in the calculation including: component-level insulation *R*-values or *U*-factors; duct system and building envelope air leakage testing assumptions; and the type and rated efficiencies of proposed heating, cooling, mechanical ventilation and service water-heating equipment to be installed. If on-site renewable energy systems will be installed, the certificate shall report the type and production size of the proposed system.
6. Where a site-specific report is not generated, the proposed design shall be based on the worst-case orientation and configuration of the rated home.

~~**R405.4.3 Additional documentation.** The *code official* shall be permitted to require the following documents:~~

- ~~1. Documentation of the building component characteristics of the *standard reference design*.~~
- ~~2. A certification signed by the builder providing the building component characteristics of the *proposed design* as given in Table R405.5.2(1).~~
- ~~3. Documentation of the actual values used in the software calculations for the *proposed design*.~~

**R405.3.2.2 Compliance report for certificate of occupancy.** A compliance report submitted for obtaining the certificate of occupancy shall include the following:

1. Building street address, or other building site identification.
2. Declaration of the total building performance path on the title page of the energy report and the title page of the building plans.
3. A statement, bearing the name of the individual performing the analysis and generating the report, indicating that the as-built building complies with Section R405.3.
4. The name and version of the compliance software tool.
5. A site-specific energy analysis report that is in compliance with Section R405.3.
6. A final confirmed certificate indicating compliance based on inspection, and a statement indicating that the confirmed rated design of the built home complies with Section R405.3. The certificate shall report the energy features that were confirmed to be in the home, including component-level insulation *R*-values or *U*-factors; results from



any required duct system and building envelope air leakage testing; and the type and rated efficiencies of the heating, cooling, mechanical ventilation and service water-heating equipment installed.

7. When on-site renewable energy systems have been installed, the certificate shall report the type and production size of the installed system.

**R405.4 Calculation procedure.** Calculations of the performance design shall be in accordance with Sections ~~R405.5.1~~ R405.4.1 and ~~R405.5.2~~ R405.4.2.

**R405.5.1 R405.4.1 General.** Except as specified by this section, the *standard reference design* and *proposed design* shall be configured and analyzed using identical methods and techniques.

**R405.5.2 R405.4.2 Residence specifications.** The *standard reference design* and *proposed design* shall be configured and analyzed as specified by Table ~~R405.5.2(1)~~ R405.4.2(1). Table ~~R405.5.2(1)~~ R405.4.2(1) shall include, by reference, all notes contained in Table ~~R402.1.2~~ R402.1.3.

**Table ~~R405.5.2(2)~~ TABLE R405.4.2(2)**  
**DEFAULT DISTRIBUTION SYSTEM EFFICIENCIES FOR PROPOSED DESIGNS<sup>a</sup>**

DISTRIBUTION SYSTEM CONFIGURATION AND CONDITION	FORCED AIR SYSTEMS	HYDRONIC SYSTEMS <sup>b</sup>
Distribution system components located in unconditioned space	—	0.95
Untested distribution systems entirely located in conditioned space <sup>c</sup>	0.88	1
“Ductless” systems <sup>d</sup>	1	—

- a. Default values in this table are for untested distribution systems, which must still meet minimum requirements for duct system insulation.
- b. Hydronic systems shall mean those systems that distribute heating and cooling energy directly to individual spaces using liquids pumped through closed-loop piping and that do not depend on ducted, forced airflow to maintain space temperatures.
- c. Entire system in *conditioned space* shall mean that no component of the distribution system, including the air-handler unit, is located outside of the *conditioned space*.
- d. Ductless systems shall be allowed to have forced airflow across a coil but shall not have any ducted airflow external to the manufacturer’s air-handler enclosure.

**R405.6 R405.5 Calculation software tools.** Calculation software, where used, shall be in accordance with Sections ~~R405.6.1~~ R405.5.1 through ~~R405.6.3~~ R405.5.3.

**R405.6.1 R405.5.1 Minimum capabilities.** Calculation procedures used to comply with this section shall be software tools capable of calculating the annual energy consumption of all building elements that differ between the *standard reference design* and the *proposed design* and shall include the following capabilities:

1. Computer generation of the *standard reference design* using only the input for the *proposed design*. The calculation procedure shall not allow the user to directly modify the building component characteristics of the *standard reference design*.
2. Calculation of whole-building (as a single *zone*) sizing for the heating and cooling equipment in the *standard reference design* residence in accordance with Section R403.6.
3. Calculations that account for the effects of indoor and outdoor temperatures and part-load ratios on the performance of heating, ventilating and air-conditioning equipment based on climate and equipment sizing.
4. Printed *code official* inspection checklist listing each of the *proposed design* component characteristics from Table R405.4.2(1) determined by the analysis to provide compliance, along with their respective performance ratings such as R-value, U-factor, SHGC, HSPF, AFUE, SEER and EF.

**R405.6.2 R405.5.2 Specific approval.** Performance analysis tools meeting the applicable provisions of Section R405 shall be permitted to be *approved*. Tools are permitted to be *approved* based on meeting a specified threshold for a jurisdiction. The *code official* shall be permitted to approve such tools for a specified application or limited scope.

**R405.6.3 R405.5.3 Input values.** When calculations require input values not specified by Sections R402, R403, R404 and R405, those input values shall be taken from an *approved* source.

~~TABLE R405.5.2(1)  
SPECIFICATIONS FOR THE STANDARD REFERENCE AND PROPOSED DESIGNS~~

<del>BUILDING COMPONENT</del>	<del>STANDARD REFERENCE DESIGN</del>	<del>PROPOSED DESIGN</del>
<del>Above-grade walls</del>	<del>Type: mass wall if proposed wall is mass; otherwise wood frame.</del>	<del>As proposed</del>
	<del>Gross area: same as proposed</del>	<del>As proposed</del>
	<del>U-factor: as specified in Table R402.1.4</del>	<del>As proposed</del>
	<del>Solar absorptance = 0.75</del>	<del>As proposed</del>
	<del>Emittance = 0.90</del>	<del>As proposed</del>
<del>Basement and crawl space walls</del>	<del>Type: same as proposed</del>	<del>As proposed</del>
	<del>Gross area: same as proposed</del>	<del>As proposed</del>
	<del>U-factor: from Table R402.1.4, with insulation layer on interior side of walls</del>	<del>As proposed</del>
<del>Above-grade floors</del>	<del>Type: wood frame</del>	<del>As proposed</del>
	<del>Gross area: same as proposed</del>	<del>As proposed</del>
	<del>U-factor: as specified in Table R402.1.4</del>	<del>As proposed</del>
<del>Ceilings</del>	<del>Type: wood frame</del>	<del>As proposed</del>
	<del>Gross area: same as proposed</del>	<del>As proposed</del>
	<del>U-factor: as specified in Table R402.1.4</del>	<del>As proposed</del>
<del>Roofs</del>	<del>Type: composition shingle on wood sheathing</del>	<del>As proposed</del>
	<del>Gross area: same as proposed</del>	<del>As proposed</del>
	<del>Solar absorptance = 0.75</del>	<del>As proposed</del>
	<del>Emittance = 0.90</del>	<del>As proposed</del>
<del>Attics</del>	<del>Type: vented with aperture = 1 ft<sup>2</sup> per 300 ft<sup>2</sup> ceiling area</del>	<del>As proposed</del>

Note to Rule Review Reviewer: Table R405.4.2(1) below, to replace Table R405.5.2(1) above, of the 2018 NC Energy Code

**TABLE R405.4.2(1)  
SPECIFICATIONS FOR THE STANDARD REFERENCE AND PROPOSED DESIGNS**

<u>BUILDING COMPONENT</u>	<u>STANDARD REFERENCE DESIGN</u>	<u>PROPOSED DESIGN</u>
<u>Above-grade walls</u>	<u>Type: mass where the proposed wall is a mass wall; otherwise wood frame.</u>	<u>As proposed</u>
	<u>Gross area: same as proposed.</u>	<u>As proposed</u>
	<u>U-factor: as specified in Table R402.1.2.</u>	<u>As proposed</u>
	<u>Solar absorptance = 0.75.</u>	<u>As proposed</u>
	<u>Emittance = 0.90.</u>	<u>As proposed</u>
<u>Basement and crawl space walls</u>	<u>Type: same as proposed.</u>	<u>As proposed</u>
	<u>Gross area: same as proposed.</u>	<u>As proposed</u>
	<u>U-factor: as specified in Table R402.1.2, with the insulation layer on the interior side of the walls.</u>	<u>As proposed</u>
<u>Above-grade floors</u>	<u>Type: wood frame.</u>	<u>As proposed</u>

	<u>Gross area: same as proposed.</u>	<u>As proposed</u>
	<u>U-factor: as specified in Table R402.1.2.</u>	<u>As proposed</u>
<u>Ceilings</u>	<u>Type: wood frame.</u>	<u>As proposed</u>
	<u>Gross area: same as proposed.</u>	<u>As proposed</u>
	<u>U-factor: as specified in Table R402.1.2.</u>	<u>As proposed</u>
<u>Roofs</u>	<u>Type: composition shingle on wood sheathing.</u>	<u>As proposed</u>
	<u>Gross area: same as proposed.</u>	<u>As proposed</u>
	<u>Solar absorptance = 0.75.</u>	<u>As proposed</u>
	<u>Emittance = 0.90.</u>	<u>As proposed</u>
<u>Attics</u>	<u>Type: vented with an aperture of 1 ft<sup>2</sup> per 300 ft<sup>2</sup> of ceiling area.</u>	<u>As proposed</u>
<u>Foundations</u>	<u>Type: same as proposed.</u>	<u>As proposed</u>
	<u>Foundation wall area above and below grade and soil characteristics: same as proposed.</u>	<u>As proposed</u>
<u>Opaque doors</u>	<u>Area: 40 ft<sup>2</sup>.</u>	<u>As proposed</u>
	<u>Orientation: North.</u>	<u>As proposed</u>
	<u>U-factor: same as fenestration as specified in Table R402.1.2.</u>	<u>As proposed</u>
<u>Vertical fenestration other than opaque doors</u>	<u>Total area<sup>h</sup> =</u> <u>(a) The proposed glazing area, where the proposed glazing area is less than 15 percent of the conditioned floor area.</u> <u>(b) 15 percent of the conditioned floor area, where the proposed glazing area is 15 percent or more of the conditioned floor area.</u>	<u>As proposed</u>
	<u>Orientation: equally distributed to four cardinal compass orientations (N, E, S &amp; W).</u>	<u>As proposed</u>
	<u>U-factor: as specified in Table R402.1.2.</u>	<u>As proposed</u>
	<u>SHGC: as specified in Table R402.1.2 except for climate zones without an SHGC requirement, the SHGC shall be equal to 0.40.</u>	<u>As proposed</u>
	<u>Interior shade fraction: 0.92 – (0.21 × SHGC for the standard reference design).</u>	<u>Interior shade fraction:</u> <u>0.92 – (0.21 × SHGC as proposed)</u>
	<u>External shading: none</u>	<u>As proposed</u>

*(continued)*

*(continued)*

**TABLE R405.4.2(1)—continued**  
**SPECIFICATIONS FOR THE STANDARD REFERENCE AND PROPOSED DESIGNS**

<u>BUILDING COMPONENT</u>	<u>STANDARD REFERENCE DESIGN</u>	<u>PROPOSED DESIGN</u>
---------------------------	----------------------------------	------------------------

<u>Skylights</u>	<u>None</u>	<u>As proposed</u>
<u>Thermally isolated sun-rooms</u>	<u>None</u>	<u>As proposed</u>
<u>Air exchange rate</u>	<u>The air leakage rate at a pressure of 0.2 inch w.g. (50 Pa) shall be Climate Zones 3 through 5: 3.0 air changes per hour.</u>	<u>The measured air exchange rate.<sup>a</sup></u>
	<u>The mechanical ventilation rate shall be in addition to the air leakage rate and shall be the same as in the proposed design, but not greater than <math>0.01 \times CFA + 7.5 \times (N_{br} + 1)</math></u> <u>where:</u> <u><math>CFA</math> = conditioned floor area, ft<sup>2</sup>.</u> <u><math>N_{br}</math> = number of bedrooms.</u> <u>The mechanical ventilation system type shall be the same as in the proposed design. Energy recovery shall not be assumed for mechanical ventilation.</u>	<u>The mechanical ventilation rate<sup>b</sup> shall be in addition to the air leakage rate and shall be as proposed.</u>
<u>Mechanical ventilation</u>	<u>Where mechanical ventilation is not specified in the proposed design: None</u> <u>Where mechanical ventilation is specified in the proposed design, the annual vent fan energy use, in units of kWh/yr, shall equal <math>(1/e_f) \times [0.0876 \times CFA + 65.7 \times (N_{br} + 1)]</math></u> <u>where:</u> <u><math>e_f</math> = the minimum exhaust fan efficacy, as specified in Table 403.6.2, corresponding to the system type at a flow rate of <math>0.01 \times CFA + 7.5 \times (N_{br} + 1)</math></u> <u><math>CFA</math> = conditioned floor area, ft<sup>2</sup>.</u> <u><math>N_{br}</math> = number of bedrooms.</u>	<u>As proposed</u>
<u>Internal gains</u>	<u>IGain, in units of Btu/day per dwelling unit, shall equal <math>17,900 + 23.8 \times CFA + 4,104 \times N_{br}</math></u> <u>where:</u> <u><math>CFA</math> = conditioned floor area, ft<sup>2</sup>.</u> <u><math>N_{br}</math> = number of bedrooms.</u>	<u>Same as standard reference design.</u>
<u>Internal mass</u>	<u>Internal mass for furniture and contents: 8 pounds per square foot of floor area.</u>	<u>Same as standard reference design, plus any additional mass specifically designed as a thermal storage element<sup>c</sup> but not integral to the building envelope or structure.</u>
<u>Structural mass</u>	<u>For masonry floor slabs: 80 percent of floor area covered by R-2 carpet and pad, and 20 percent of floor directly exposed to room air.</u>	<u>As proposed</u>
	<u>For masonry basement walls: as proposed, but with insulation as specified in Table R402.1.3, located on the interior side of the walls.</u>	<u>As proposed</u>
	<u>For other walls, ceilings, floors, and interior walls: wood frame construction.</u>	<u>As proposed</u>

<u>Heating systems<sup>d, e</sup></u>	<p>For other than electric heating without a heat pump: as proposed.</p> <p>Where the proposed design utilizes electric heating without a heat pump, the standard reference design shall be an air source heat pump meeting the requirements of Section C403 of the IECC—Commercial Provisions.</p> <p>Capacity: sized in accordance with Section R403.7.</p>	As proposed
<u>Cooling systems<sup>d, f</sup></u>	<p>As proposed.</p> <p>Capacity: sized in accordance with Section R403.7.</p>	As proposed

(continued)

(continued)

**TABLE R405.4.2(1)—continued**  
**SPECIFICATIONS FOR THE STANDARD REFERENCE AND PROPOSED DESIGNS**

BUILDING COMPONENT	STANDARD REFERENCE DESIGN	PROPOSED DESIGN		
<u>Service water heating<sup>d, g</sup></u>	<p>As proposed.</p> <p>Use, in units of gal/day = <math>30 + (10 \times N_{br})</math></p> <p>where:  <math>N_{br}</math> = number of bedrooms.</p>	<p>As proposed</p> <p>Use, in units of gal/day = <math>25.5 + (8.5 \times N_{br}) \times (1 - HWDS)</math></p> <p>where:  <math>N_{br}</math> = number of bedrooms.  <math>HWDS</math> = factor for the compactness of the hot water distribution system.</p>		
		<b>Compactness ratio<sup>i</sup> factor</b>		<b>HWDS</b>
		1 story	2 or more stories	
		≥ 60%	≥ 30%	0
		> 30% to ≤ 60%	> 15% to ≤ 30%	0.05
		> 15% to ≤ 30%	> 7.5% to ≤ 15%	0.10
		< 15%	< 7.5%	0.15
<u>Thermal distribution systems</u>	<p>Duct insulation: in accordance with Section R403.3.1.</p> <p>A thermal distribution system efficiency (DSE) of 0.88 shall be applied to both the heating and cooling system efficiencies for all systems other than tested duct systems.</p> <p>Duct location: same as proposed design.</p> <p><b>Exception:</b> For nonducted heating and cooling systems that do not have a fan, the standard reference design thermal distribution system efficiency (DSE) shall be 1. For tested duct systems, the leakage rate shall be 4 cfm (113.3 L/min) per 100 ft<sup>2</sup> (9.29 m<sup>2</sup>) of conditioned floor area at a pressure of differential of 0.1 inch w.g. (25 Pa).</p>	<p>Duct insulation: as proposed.</p> <p>As tested or, where not tested, as specified in Table R405.4.2(2).</p>		
<u>Thermostat</u>	<p>Type: Manual, cooling temperature setpoint = 75°F;  Heating temperature setpoint = 72°F.</p>	Same as standard reference design.		

<u>Dehumidistat</u>	<u>Where a mechanical ventilation system with latent heat recovery is not specified in the proposed design:</u>	<u>Same as standard reference design.</u>
	<u>None.</u>	
	<u>Where the proposed design utilizes a mechanical ventilation system with latent heat recovery:</u>	
	<u>Dehumidistat type: manual, setpoint = 60% relative humidity.</u> <u>Dehumidifier: whole-dwelling with integrated energy factor = 1.77 liters/kWh.</u>	

For SI: 1 square foot = 0.93 m<sup>2</sup>, 1 British thermal unit = 1055 J, 1 pound per square foot = 4.88 kg/m<sup>2</sup>, 1 gallon (US) = 3.785 L, °C = (°F-32)/1.8, 1 degree = 0.79 rad.

- a. Where required by the *code official*, testing shall be conducted by an *approved party*. Hourly calculations as specified in the *ASHRAE Handbook of Fundamentals*, or the equivalent, shall be used to determine the energy loads resulting from infiltration.
- b. The combined air exchange rate for infiltration and mechanical ventilation shall be determined in accordance with Equation 43 of 2001 *ASHRAE Handbook of Fundamentals*, page 26.24 and the “Whole-house Ventilation” provisions of 2001 *ASHRAE Handbook of Fundamentals*, page 26.19 for intermittent mechanical ventilation.
- c. Thermal storage element shall mean a component that is not part of the floors, walls or ceilings that is part of a passive solar system, and that provides thermal storage such as enclosed water columns, rock beds, or phase-change containers. A thermal storage element shall be in the same room as fenestration that faces within 15 degrees (0.26 rad) of true south, or shall be connected to such a room with pipes or ducts that allow the element to be actively charged.
- d. For a proposed design with multiple heating, cooling or water heating systems using different fuel types, the applicable standard reference design system capacities and fuel types shall be weighted in accordance with their respective loads as calculated by accepted engineering practice for each equipment and fuel type present.
- e. For a proposed design without a proposed heating system, a heating system having the prevailing federal minimum efficiency shall be assumed for both the standard reference design and proposed design.
- f. For a proposed design home without a proposed cooling system, an electric air conditioner having the prevailing federal minimum efficiency shall be assumed for both the standard reference design and the proposed design.
- g. For a proposed design with a nonstorage-type water heater, a 40-gallon storage-type water heater having the prevailing federal minimum energy factor for the same fuel as the predominant heating fuel type shall be assumed. For a proposed design without a proposed water heater, a 40-gallon storage-type water heater having the prevailing federal minimum efficiency for the same fuel as the predominant heating fuel type shall be assumed for both the proposed design and standard reference design.

**TABLE R405.4.2(1)—continued**

**SPECIFICATIONS FOR THE STANDARD REFERENCE AND PROPOSED DESIGNS**

- g. For a proposed design with a nonstorage-type water heater, a 40-gallon storage-type water heater having the prevailing federal minimum energy factor for the same fuel as the predominant heating fuel type shall be assumed. For a proposed design without a proposed water heater, a 40-gallon storage-type water heater having the prevailing federal minimum efficiency for the same fuel as the predominant heating fuel type shall be assumed for both the proposed design and standard reference design.

h. For residences with conditioned basements, R-2 and R-4 residences, and for townhouses, the following formula shall be used to determine glazing area:

$$AF = A_s \times FA \times F$$

where:

$AF$  = Total glazing area.

$A_s$  = Standard reference design total glazing area.

$FA$  = (Above grade thermal boundary gross wall area)/(above grade boundary wall area + 0.5 × below grade boundary wall area).

$F$  = (above grade thermal boundary wall area)/(above grade thermal boundary wall area + common wall area) or 0.56, whichever is greater.

and where:

— Thermal boundary wall is any wall that separates conditioned space from unconditioned space or ambient conditions.

— Above grade thermal boundary wall is any thermal boundary wall component not in contact with soil.

— Below grade boundary wall is any thermal boundary wall in soil contact.

— Common wall area is the area of walls shared with an adjoining dwelling unit.

- i. The factor for the compactness of the hot water distribution system is the ratio of the area of the rectangle that bounds the source of hot water and the fixtures that it serves (the “hot water rectangle”) divided by the floor area of the dwelling.

1. Sources of hot water include water heaters, or in multiple-family buildings with central water heating systems, circulation loops or electric heat traced pipes.
2. The hot water rectangle shall include the source of hot water and the points of termination of all hot water fixture supply piping.
3. The hot water rectangle shall be shown on the floor plans and the area shall be computed to the nearest square foot.
4. Where there is more than one water heater and each water heater serves different plumbing fixtures and appliances, it is permissible to establish a separate hot water rectangle for each hot water distribution system and add the area of these rectangles together to determine the compactness ratio.
5. The basement or attic shall be counted as a story when it contains the water heater.

6. Compliance shall be demonstrated by providing a drawing on the plans that shows the hot water distribution system rectangle(s), comparing the area of the rectangle(s) to the area of the dwelling and identifying the appropriate compactness ratio and *HWDS* factor.

## SECTION R406 ENERGY RATING INDEX COMPLIANCE ALTERNATIVE

**R406.1 Scope.** This section establishes criteria for compliance using an Energy Rating Index (ERI) analysis.

~~**R406.2 Mandatory requirements.** Compliance with this section requires that the provisions identified in Sections R401 through R404 labeled as “mandatory” be met. The building thermal envelope shall be greater than or equal to levels of efficiency and Solar Heat Gain Coefficient in Table 402.1.1 or 402.1.3 of the 2012 *North Carolina Energy Conservation Code*. Minimum standards associated with compliance shall be the ANSI RESNET ICC Standard 301—2014 “Standard for the Calculation and Labeling of the Energy Performance of Low Rise Residential Buildings using an Energy Rating Index.” A North Carolina *registered design professional* or certified *HERS rater* is required to perform the analysis if required by North Carolina licensure laws.~~

**Exception:** Supply and return ducts in *unconditioned space* and outdoors shall be insulated to a minimum R-8. Supply ducts inside semi-conditioned space shall be insulated to a minimum R-4; return ducts inside conditioned and semi-conditioned space are not required to be insulated. Ducts located inside conditioned space are not required to be insulated other than as may be necessary for preventing the formation of condensation on the exterior of cooling ducts.

**R406.2 ERI compliance.** Compliance based on the ERI requires that the rated design meets all of the following:

1. The requirements of the sections indicated within Table R406.2.
2. Maximum ERI of Table R406.5.

**TABLE R406.2  
REQUIREMENTS FOR ENERGY RATING INDEX**

SECTION <sup>a</sup>	TITLE
<b>General</b>	
<u>R401.2.5</u>	<u>Additional efficiency packages</u>
<u>R401.3</u>	<u>Certificate</u>
<b>Building Thermal Envelope</b>	
<u>R402.1.1</u>	<u>Vapor retarder</u>
<u>R402.2.3</u>	<u>Eave baffle</u>
<u>R402.2.4.1</u>	<u>Access hatches and doors</u>
<u>R402.2.10.1</u>	<u>Crawl space wall insulation installation</u>
<u>R402.4.1.1</u>	<u>Installation</u>
<u>R402.4.1.2</u>	<u>Testing</u>
<b>Mechanical</b>	
<u>R403.1</u>	<u>Controls</u>
<u>R403.3 except Sections R403.3.2, R403.3.3 and R403.3.6</u>	<u>Ducts</u>
<u>R403.4</u>	<u>Mechanical system piping insulation</u>
<u>R403.5.1</u>	<u>Heated water calculation and temperature maintenance systems</u>

<u>R403.5.3</u>	<u>Drain water heat recovery units</u>
<u>R403.6</u>	<u>Mechanical ventilation</u>
<u>R403.7</u>	<u>Equipment sizing and efficiency rating</u>
<u>R403.8</u>	<u>Systems serving multiple dwelling units</u>
<u>R403.9</u>	<u>Snow melt and ice systems</u>
<u>R403.10</u>	<u>Energy consumption of pools and spas</u>
<u>R403.11</u>	<u>Portable spas</u>
<u>R403.12</u>	<u>Residential pools and permanent residential spas</u>
<b><u>Electrical Power and Lighting Systems</u></b>	
<u>R404.1</u>	<u>Lighting equipment</u>
<u>404.2</u>	<u>Interior lighting controls</u>
<u>R406.3</u>	<u>Building thermal envelope</u>

a. Reference to a code section includes all of the relative subsections except as indicated in the table.

## 2018 NC Energy Conservation Code

### R406 Energy Rating Index. (161213 Item B-3.3)

#### SECTION R406

#### ENERGY RATING INDEX COMPLIANCE ALTERNATIVE

**R406.1 Scope.** This section establishes criteria for compliance using an Energy Rating Index (ERI) analysis.

**R406.2 Mandatory requirements.**

Compliance with this section requires that the mandatory provisions identified in Sections R401.2 R401 through R404 labeled as "mandatory" and Section R403.5.3 be met. The building thermal envelope shall be greater than or equal to levels of efficiency and Solar Heat Gain Coefficient in Table 402.1.1 or 402.1.3 of the 2009 International Energy Conservation Code 2012 NC Energy Conservation Code. Minimum standards associated with compliance shall be the ANSI RESNET ICC Standard 301-2014 "Standard for the Calculation and Labeling of the Energy Performance of Low-Rise Residential Buildings using an Energy Rating Index." A North Carolina licensed design professional or certified HERS rater is required to perform the analysis if required by North Carolina licensure laws.

Exception: Supply and return ducts not completely inside the building thermal envelope shall be insulated to a minimum of R-6. Supply and return ducts in unconditioned space and outdoors shall be insulated to a minimum R-8. Supply ducts inside semi-conditioned space shall be insulated to a minimum R-4; return ducts inside conditioned and semi-conditioned space are not required to be insulated. Ducts located inside conditioned space are not required to be insulated other than as may be necessary for preventing the formation of condensation on the exterior of cooling ducts.

**R406.5 Verification by approved agency.**

Verification of compliance with Section R406 shall be performed by the licensed design professional or certified HERS rater and the compliance documentation shall be provided to the code official. The code official shall inspect according to the requirements of Section R406.6.2 completed by an approved third party.



2018 NC Energy Code  
 R406.2 Mandatory requirements. (200901 Item B-15)

**R406.2 Mandatory requirements.** Compliance with this section requires that the provisions identified in Sections R401 through R404 labeled as “mandatory” be met. The building thermal envelope shall be greater than or equal to levels of efficiency and Solar Heat Gain Coefficient in Table R406.2.1 or Table R406.2.2, Table 402.1.1 or 402.1.3 of the 2012 North Carolina Energy Conservation Code. Minimum standards associated with compliance shall be the ANSI RESNET ICC Standard 301-2014: “Standard for the Calculation and Labeling of the Energy Performance of Low-Rise Residential Buildings using an Energy Rating Index.” A North Carolina *registered design professional* or certified *HERS rater* is required to perform the analysis if required by North Carolina licensure laws.

**Exception:** Supply and return ducts in unconditioned space and outdoors shall be insulated to a minimum R-8. Supply ducts inside semi-conditioned space shall be insulated to a minimum R-4; return ducts inside conditioned and semi-conditioned space are not required to be insulated. Ducts located inside conditioned space are not required to be insulated other than as may be necessary for preventing the formation of condensation on the exterior of cooling ducts.

**TABLE R406.2.1**  
**MINIMUM INSULATION AND FENESTRATION REQUIREMENTS FOR ENERGY RATING INDEX COMPLIANCE<sup>a</sup>**

CLIMATE ZONE	FENESTRATION VALUES			R-VALUES FOR								
	FENESTRATION U-FACTOR <sup>b,d</sup>	SKYLIGHT <sup>b</sup> U-FACTOR	GLAZED FENESTRATION SHGC <sup>b,k</sup>	CEILING	UNVENTED <sup>e</sup> RAFTER ASSEMBLIES IN ATTICS CONTAINING DUCTWORK, AIR-IMPERMEABLE	UNVENTED <sup>e</sup> RAFTER ASSEMBLIES IN ATTICS CONTAINING DUCTWORK, AIR-PERMIABLE/IMPERMEABLE	WOOD FRAME WALL	MASS WALL <sup>l</sup>	FLOOR	BASEMENT <sup>m</sup> WALL	SLAB <sup>n</sup>	CRAWL SPACE <sup>c</sup> WALL
3	0.35	0.65	0.3	30	20	15-10 <sup>o</sup>	13	5/10	19	10/13 <sup>f</sup>	0	5/13
4	0.35	0.6	0.3	38 or 30ci <sup>l</sup>	20	15-10 <sup>o</sup>	15, 13+2.5 <sup>o</sup>	5/10	19	10/13	10	10/13
5	0.35	0.6	NR	38 or 30ci <sup>l</sup>	25	15-20 <sup>o</sup>	19 <sup>n</sup> , 13+5 <sup>o</sup> , or 15+3 <sup>o</sup>	13/17	30 <sup>o</sup>	10/13	10	10/13

requirements of 1205.2 of the North Carolina Building Code. Exposed rafters shall be covered with R-7 insulation.

g. The value for air-permeable insulation is shown first and that for air-impermeable insulation second. Thus, R-15 + R-10 indicates that the minimum value for air-permeable insulation is R-15, and the minimum value for air-impermeable insulation is R-10. Air-impermeable insulation shall be installed in direct contact with the underside of the structural roof sheathing. The air-permeable insulation shall be installed directly under the air-impermeable insulation. Exposed rafters shall be covered with R-7 insulation.

**TABLE R406.2.2**  
**EQUIVALENT U-FACTORS FOR TABLE R406.2.1<sup>a</sup>**

CLIMATE ZONE	FENESTRATION <sup>a</sup>	SKYLIGHT U-FACTOR	CEILING	UNVENTED <sup>a</sup> RAFTER ASSEMBLIES IN ATTICS CONTAINING DUCTWORK, AIR-IMPERMEABLE	UNVENTED <sup>a</sup> RAFTER ASSEMBLIES IN ATTICS CONTAINING DUCTWORK, AIR-PERMEABLE/IMPERMEABLE	FRAME WALL	MASS WALL <sup>b</sup>	FLOOR	BASEMENT <sup>d</sup> WALL	CRAWL SPACE <sup>c</sup> WALL
3	0.35	0.65	0.0350	0.05	0.043 <sup>f</sup>	0.082	0.141	0.047	0.059	0.136
4	0.35	0.60	0.0300	0.05	0.043 <sup>f</sup>	0.077	0.141	0.047	0.059	0.065
5	0.35	0.60	0.0300	0.037	0.034 <sup>f</sup>	0.061	0.082	0.033	0.059	0.065

- a. Nonfenestration U-factors shall be obtained from measurement, calculation or an approved source.
- b. When more than half the insulation is on the interior, the mass wall U-factors shall be a maximum of 0.07 in Climate Zone 3, 0.07 in Climate Zone 4 and 0.054 in Climate Zone 5.
- c. Basement wall U-factor of 0.360 in warm-humid locations as defined by Figure R501.1 and Table R301.1.
- d. A maximum of two glazed fenestration product assemblies having a U-factor no greater than 0.55 and a SHGC no greater than 0.70 shall be permitted to be substituted for minimum code compliant fenestration product assemblies without penalty. When applying this note and using the RESCheck "UA Trade-off" compliance method to allow continued use of the software, the applicable fenestration products shall be modeled as meeting the U-factor of 0.35 and the SHGC of 0.30, as applicable, but the fenestration products' actual U-factor and actual SHGC shall be noted in the comments section of the software for documentation of application of this note to the applicable products. Compliance for these substitute products shall be verified compared to the allowed substituted maximum U-value requirement and maximum SHGC requirement, as applicable.

August 13, 2021

**R406.3 Building thermal envelope.** Building and portions thereof shall comply with Section R406.3.1 or R406.3.2.

**R406.3.1 On-site renewables are not included.** Where on-site renewable energy is not included for compliance using the ERI analysis of Section R406.4, the proposed total building thermal envelope UA, which is sum of U-factor times assembly area, shall be less than or equal to the building thermal envelope UA using the prescriptive U-factors from Table R402.1.2 multiplied by 1.15 in accordance with Equation 4-1. The area-weighted maximum fenestration SHGC permitted in Climate Zones 0 through 3 shall be 0.30.

$$UA_{\text{Proposed design}} = 1.15 \times UA_{\text{Prescriptive reference design}}$$

**(Equation 4-1)**

**R406.3.2 On-site renewables are included.** Where on-site renewable energy is included for compliance using the ERI analysis of Section R406.4, the building thermal envelope shall be greater than or equal to the levels of efficiency and SHGC in Table R402.1.2 or Table R402.1.4 of the 2015 *International Energy Conservation Code*.

**R406.3 Energy Rating Index.** The Energy Rating Index (ERI) shall be a numerical integer value that is based on a linear scale constructed such that the *ERI reference design* has an Index value of 100 and a *residential building* that uses no net-purchased energy has an Index value of 0. Each integer value on the scale shall represent a 1 percent change in the total energy use of the rated design relative to the total energy use of the *ERI reference design*. The ERI shall consider all energy used in the *residential building*.

**R406.3.1 ERI reference design.** The *ERI reference design* shall be configured such that it meets the minimum

requirements of the 2006 *International Energy Conservation Code* prescriptive requirements. The proposed *residential building* shall be shown to have an annual total normalized modified load less than or equal to the annual total loads of the *ERI reference design*.

**R406.4 ERI-based compliance.** Compliance based on an ERI analysis requires that the *rated design* be shown to have an ERI less than or equal to the appropriate value listed in Table R406.4.1 or Table R406.4.2, as applicable, when compared to the *ERI reference design*.

R406.4.1

<u>MAXIMUM ENERGY RATING INDEX</u> <u>(without calculation of on-site renewable energy)</u>		
<u>CLIMATE ZONE</u>	<u>Jan 1, 2019– Dec 31, 2022</u>	<u>Jan 1, 2023 and forward</u>
<u>3</u>	<u>65</u>	<u>61</u>
<u>4</u>	<u>67</u>	<u>63</u>
<u>5</u>	<u>67</u>	<u>63</u>

R406.4.2

MAXIMUM ENERGY RATING INDEX  
(including calculation of on-site renewable energy)

<u>CLIMATE ZONE</u>	<u>Jan 1, 2019– Dec 31, 2022</u>	<u>Jan 1, 2023 and forward</u>
<u>3</u>	<u>51</u>	<u>47</u>
<u>4</u>	<u>54</u>	<u>50</u>
<u>5</u>	<u>55</u>	<u>51</u>

**R406.3 R406.4 Energy Rating Index.** The Energy Rating Index (ERI) shall be determined in accordance with RESNET/ICC 301 except for buildings covered by the *International Residential Code*, the ERI reference design ventilation rate shall be in accordance with Equation 4-2.

Ventilation rate, CFM = (0.01 × total square foot area of house) + [7.5 × (number of bedrooms + 1)]  
**(Equation 4-2)**

Energy used to recharge or refuel a vehicle used for transportation on roads that are not on the building site shall not be included in the *ERI reference design* or the *rated design*. For compliance purposes, any reduction in energy use of the rated design associated with on-site renewable energy shall not exceed 5 percent of the total energy use.

**R406.5 ERI-based compliance.** Compliance based on an ERI analysis requires that the *rated proposed design* and confirmed built dwelling be shown to have an ERI less than or equal to the appropriate value indicated in Table R406.5 when compared to the *ERI reference design*.

Table R406.4.1 TABLE R406.5

MAXIMUM ENERGY RATING INDEX

<u>CLIMATE ZONE</u>	<u>ENERGY RATING INDEX</u>
<u>3</u>	<u>51</u>

4	54
5	55

~~**R406.5 Verification.** Verification of compliance with Section R406 shall be performed by the *registered design professional* or *certified HERS rater* and the compliance documentation shall be provided to the code official. The code official shall inspect according to the requirements of Section R406.6.2.~~

**R406.5 R406.6 Verification by approved agency.** Verification of compliance with Section R406 as outlined in Sections R406.4 and R406.6 shall be completed by an *approved* third party. Verification of compliance with Section R406.2 shall be completed by the authority having jurisdiction or an *approved* third-party inspection agency in accordance with Section R105.4.

~~**R406.6 R406.7 Documentation.** Documentation of the software used to determine the ERI and the parameters for the *residential building* shall be in accordance with Sections R406.6.1 R406.7.1 through ~~R406.6.3~~ R406.7.4.~~

~~**R406.7 Calculation software tools.** Calculation software, where used, shall be in accordance with Sections R406.7.1 through R406.7.3.~~

~~**R406.7.1 Minimum capabilities.** Calculation procedures used to comply with this section shall be software tools capable of calculating the ERI as described in Section R406.3, and shall be in compliance with ANSI RESNET ICC Standard 301—2014. The software shall include the following capabilities:~~

- ~~1. Computer generation of the *ERI reference design* using only the input for the *rated design*.  
The calculation procedure shall not allow the user to directly modify the building component characteristics of the *ERI reference design*.~~
- ~~2. Calculation of whole building, as a single *zone*, sizing for the heating and cooling equipment in the *ERI reference design* residence in accordance with Section R403.7.~~
- ~~3. Calculations that account for the effects of indoor and outdoor temperatures and part load ratios on the performance of heating, ventilating and air conditioning equipment based on climate and equipment sizing.~~
- ~~4. Printed *code official* inspection checklist listing each of the *rated design* component characteristics determined by the analysis to provide compliance, along with their respective performance ratings.~~

~~**R406.6.1 R406.7.1 Compliance software tools.** Compliance software tools for this section shall be in compliance with ANSI RESNET ICC Standard 301—2014. Software tools used for determining ERI shall be Approved Software Rating Tools in accordance with RESNET/ICC 301.~~

~~**R406.6.2 Compliance report.** Compliance software tools shall generate a report that documents that the ERI of the *rated design* complies with Sections R406.3 and R406.4. The compliance documentation shall include the following information:~~

- ~~1. Address or other identification of the residential building.~~
- ~~2. An inspection checklist documenting the building component characteristics of the *rated design*. The inspection checklist shall show results for both the *ERI reference design* and the *rated design*, and shall document all inputs entered by the user necessary to reproduce the results.~~
- ~~3. Name of individual completing the compliance report.~~

4. ~~Name and version of the compliance software tool.~~

**R406.6.2 R406.7.2 Compliance report.** Compliance software tools shall generate a report that documents that the home and the ERI score of the *rated design* complies with Sections R406.2, R406.3 and R406.4. Compliance documentation shall be created for the proposed design and shall be submitted with the application for the building permit. Confirmed compliance documents of the built *dwelling unit* shall be created and submitted to the code official for review before a certificate of occupancy is issued. Compliance reports shall include information in accordance with Sections R406.7.2.1 and R406.7.2.2.

**R406.7.2.1 Proposed compliance report for permit application.** Compliance reports submitted with the application for a building permit shall include the following:

1. Building street address, or other *building site* identification.
2. Declare ERI on title page and building plans.
3. The name of the individual performing the analysis and generating the compliance report.
4. The name and version of the compliance software tool.
5. Documentation of all inputs entered into the software used to produce the results for the reference design and/or the rated home.
6. A certificate indicating that the proposed design has an ERI less than or equal to the appropriate score indicated in Table R406.5 when compared to the ERI reference design. The certificate shall document the building component energy specifications that are included in the calculation, including: component level insulation *R*-values or *U*-factors; assumed duct system and building envelope air leakage testing results; and the type and rated efficiencies of proposed heating, cooling, mechanical ventilation, and service water-heating equipment to be installed. If on-site renewable energy systems will be installed, the certificate shall report the type and production size of the proposed system.
7. When a site-specific report is not generated, the proposed design shall be based on the worst-case orientation and configuration of the rated home.

**R406.7.2.2 Confirmed compliance report for a certificate of occupancy.** A confirmed compliance report submitted for obtaining the certificate of occupancy shall be made site and address specific and include the following:

1. Building street address or other *building site* identification.
2. Declaration of ERI on title page and on building plans.
3. The name of the individual performing the analysis and generating the report.
4. The name and version of the compliance software tool.
5. Documentation of all inputs entered into the software used to produce the results for the reference design and/or the rated home.
6. A final confirmed certificate indicating that the confirmed rated design of the built home complies with Sections R406.2 and R406.4. The certificate shall report the energy features that were confirmed to be in the home, including: component-level insulation *R*-values or *U*-factors; results from any required duct system and building envelope air leakage testing; and the type and rated efficiencies of the heating, cooling, mechanical ventilation, and service water-heating equipment installed. Where on-site renewable energy systems have been installed on or in the home, the certificate shall report the type and production size of the installed system.

**R406.7.3 Renewable energy certificate (REC) documentation.** Where on-site renewable energy is included in the calculation of an ERI, one of the following forms of documentation shall be provided to the code official:

1. Substantiation that the RECs associated with the on-site renewable energy are owned by, or retired on behalf of, the homeowner.
2. A contract that conveys to the homeowner the RECs associated with the on-site renewable energy, or conveys to the homeowner an equivalent quantity of RECs associated with other renewable energy.

**R406.6.3 Additional documentation.** Deleted.

~~R406.6.3~~ **R406.7.4 Additional documentation.** The code official shall be permitted to require the following documents:

1. Documentation of the building component characteristics of the *ERI reference design*.
2. A certification signed by the builder providing the building component characteristics of the *rated design*.
3. Documentation of the actual values used in the software calculations for the *rated design*.

~~R406.7.2 Specific approval.~~ Deleted. **R406.7.5 Specific approval.** Performance analysis tools meeting the applicable subsections of Section R406 shall be *approved*. Documentation demonstrating the approval of performance analysis tools in accordance with Section R406.7.1 shall be provided.

~~R406.7.3 Input values.~~ Deleted. **R406.7.6 Input values.** Where calculations require input values not specified by Sections R402, R403, R404 and R405, those input values shall be taken from RESNET/ICC 301.

## **\*\* SECTION R407**

### **TROPICAL CLIMATE REGION COMPLIANCE PATH**

This section is unchanged, it is not used.

## **SECTION R408**

### **ADDITIONAL EFFICIENCY PACKAGE OPTIONS**

**R408.1 Scope.** This section establishes additional efficiency package options to achieve additional energy efficiency in accordance with Section R401.2.5.

**R408.2 Additional efficiency package options.** Additional efficiency package options for compliance with Section R401.2.1 are set forth in Sections R408.2.1 through R408.2.5.

**R408.2.1 Enhanced envelope performance option.** The total *building thermal envelope* UA, the sum of *U*-factor times assembly area, shall be less than or equal to 95 percent of the total UA resulting from multiplying the *U*-factors in Table R402.1.2 by the same assembly area as in the proposed building. The UA calculation shall be performed in accordance with Section R402.1.5. The area-weighted average SHGC of all glazed fenestration shall be less than or equal to 95 percent of the maximum glazed fenestration SHGC in Table R402.1.2.

**R408.2.2 More efficient HVAC equipment performance option.** Heating and cooling *equipment* shall meet one of the following efficiencies:

1. Greater than or equal to 95 AFUE natural gas furnace and 16 SEER air conditioner.
2. Greater than or equal to 10 HSPF/16 SEER air source heat pump.
3. Greater than or equal to 3.5 COP ground source heat pump.

For multiple cooling systems, all systems shall meet or exceed the minimum efficiency requirements in this section and shall be sized to serve 100 percent of the cooling design load. For multiple heating systems, all systems shall meet or exceed the minimum efficiency requirements in this section and shall be sized to serve 100 percent of the heating design load.

**R408.2.3 Reduced energy use in service water-heating option.** The hot water system shall meet one of the following efficiencies:

1. Greater than or equal to 82 EF fossil fuel service water-heating system.
2. Greater than or equal to 2.0 EF electric service water-heating system.
3. Greater than or equal to 0.4 solar fraction solar water-heating system.

**R408.2.4 More efficient duct thermal distribution system option.** The thermal distribution system shall meet one of the following efficiencies:

1. 100 percent of ducts and air handlers located entirely within the *building thermal envelope*.

2. 100 percent of ductless thermal distribution system or hydronic thermal distribution system located completely inside the building thermal envelope.
3. 100 percent of duct thermal distribution system located in conditioned space as defined by Section R403.3.2.

**R408.2.5 Improved air sealing and efficient ventilation system option.** The measured air leakage rate shall be less than or equal to 3.0 ACH50, with either an Energy Recovery Ventilator (ERV) or Heat Recovery Ventilator (HRV) installed. Minimum HRV and ERV requirements, measured at the lowest tested net supply airflow, shall be greater than or equal to 75 percent Sensible Recovery Efficiency (SRE), less than or equal to 1.1 cubic feet per minute per watt (0.03 m<sup>3</sup>/min/watt) and shall not use recirculation as a defrost strategy. In addition, the ERV shall be greater than or equal to 50 percent Latent Recovery/Moisture Transfer (LRMT).

# CHAPTER 5 [RE] EXISTING BUILDINGS

## SECTION R501 GENERAL

**R501.1 Scope.** The provisions of this chapter shall control the *alteration, repair, addition* and change of occupancy of existing *buildings* and structures.

**~~R501.1.1 Additions, alterations, or repairs: General.~~** ~~Additions, alterations, or repairs to an existing building, building system or portion thereof shall comply with Section R502, R503, or R504. Except as specified in this chapter, this code shall not be used to require the removal, alteration or abandonment of, nor prevent the continued use and maintenance of, an existing building or building system lawfully in existence at the time of adoption of this code. Unaltered portions of the existing building or building supply system shall not be required to comply with this code.~~

**~~R501.2 Existing buildings.~~** ~~Except as specified in this chapter, this code shall not be used to require the removal, alteration or abandonment of, nor prevent the continued use and maintenance of, an existing building or building system lawfully in existence at the time of adoption of this code.~~

**R501.2 Compliance.** *Additions, alterations, repairs* or changes of occupancy to, or relocation of, an existing *building, building system* or portion thereof shall comply with Section R502, R503, R504 or R505, respectively, in this code. Changes where unconditioned space is changed to *conditioned space* shall comply with Section R502.

**~~R501.3 Maintenance.~~** ~~Deleted.~~

**R501.3 Maintenance.** *Buildings* and structures, and parts thereof, shall be maintained in a safe and sanitary condition. Devices and systems that are required by this code shall be maintained in conformance to the code edition under which installed. The owner or the owner's authorized agent shall be responsible for the maintenance of buildings and structures. The requirements of this chapter shall not provide the basis for removal or abrogation of energy conservation, fire protection and safety systems and devices in existing structures.

**R501.4 Compliance.** *Alterations, repairs, additions* and changes of occupancy to, or relocation of, existing buildings and structures shall comply with the provisions for *alterations, repairs, additions* and changes of occupancy or relocation, respectively, in this code and the *International Residential Code, International Building Code, International Existing Building Code, International Fire Code, International Fuel Gas Code, International Mechanical Code, International Plumbing Code, the ~~North Carolina Existing Building Code, International Property Maintenance Code, International Private Sewage Disposal Code~~* and NFPA 70.

**R501.5 New and replacement materials.** Except as otherwise required or permitted by this code, materials permitted by the applicable code for new construction shall be used. Like materials shall be permitted for *repairs*, provided that hazards to life, health or property are not created. Hazardous materials shall not be used where the code for new construction would not allow their use in *buildings* of similar occupancy, purpose and location.

**~~R501.6 Historic buildings.~~** ~~No provision of this code relating to the construction, repair, alteration, restoration and movement of structures, and change of occupancy shall be mandatory for historic buildings.~~

**R501.6 Historic buildings.** Provisions of this code relating to the construction, repair, alteration, restoration and movement of structures, and change of occupancy shall not be mandatory for historic buildings provided that a report has been submitted to the code official and signed by the owner, a registered design professional, or a representative of the State Historic Preservation Office or the historic preservation authority having jurisdiction, demonstrating that compliance with that provision would threaten, degrade or destroy the historic form, fabric or function of the building.

## SECTION R502 ADDITIONS



**R502.1 General.** *Additions* to an existing *building*, *building* system or portion thereof shall conform to the provisions of this code as those provisions relate to new construction without requiring the unaltered portion of the existing *building* or *building* system to comply with this code. *Additions* shall not create an unsafe or hazardous condition or overload existing *building* systems. An *addition* shall be deemed to comply with this code where the *addition* alone complies, where the existing *building* and *addition* comply with this code as a single building, or where the *building* with the *addition* does not use more energy than the existing *building*. *Additions* shall be in accordance with Section ~~R502.1.1~~ R502.2 or ~~R502.1.2~~ R502.3. □

**R502.2 Change in space conditioning.** Any unconditioned or low-energy space that is altered to become *conditioned space* shall be required to be brought into full compliance with this code.

**Exceptions:**

1. Where the simulated performance option in Section R405 is used to comply with this section, the annual energy cost of the *proposed design* is permitted to be 110 percent of the annual energy cost otherwise allowed by Section R405.2.
2. Where the Total UA, as determined in Section R402.1.5, of the existing *building* and the *addition*, and any *alterations* that are part of the project, is less than or equal to the Total UA generated for the existing *building*.
3. Where complying in accordance with Section R405 and the annual energy cost or energy use of the *addition* and the existing *building*, and any *alterations* that are part of the project, is less than or equal to the annual energy cost of the existing *building*. The *addition* and any *alterations* that are part of the project shall comply with Section R405 in its entirety.

**R502.1.1 R502.3 Prescriptive compliance.** *Additions* shall comply with Sections ~~R502.1.1.1~~ R502.3.1 through ~~R502.1.1.4~~ R502.3.4.

**R502.1.1.1 R502.3.1 Building envelope.** New *building* ~~thermal~~ envelope assemblies that are part of the *addition* shall comply with Sections R402.1, R402.2, R402.3.1 through R402.3.5, and R402.4.

**Exception:** New envelope assemblies are exempt from the requirements of Section R402.4.1.2.

**R502.1.1.2 Heating and cooling systems.** New heating, cooling and duct systems that are part of the *addition* shall comply with Sections R403.1, R403.2, R403.3, ~~R403.4~~ and R403.6. New heating and cooling appliances shall be sized in accordance with Section R403.7. Extensions of ducts from an existing system to a new *addition* shall require that the existing system be evaluated for the new design.

**R502.3.2 Heating and cooling systems.** HVAC ducts newly installed as part of an *addition* shall comply with Section R403.

**Exception:** Where ducts from an existing heating and cooling system are extended to an *addition*.

**R502.1.1.3 R502.3.3 Service hot water systems.** New service hot water systems that are part of the *addition* shall comply with Section R403.5.

**R502.1.1.4 R502.3.4 Lighting.** New lighting systems that are part of the *addition* shall comply with Section R404.1.

~~**R502.1.2 Simulated Performance Alternative.** The *addition* shall comply with Section R405, as applicable.~~

## SECTION R503 ALTERATIONS

**R503.1 General.** *Alterations* to any building or structure shall comply with the requirements of the code for new construction, without requiring the unaltered portions of the existing building or building system to comply with this code. *Alterations* shall be such that the existing building or structure is not less conforming to the provisions of this code than the existing *building* or structure was prior to the *alteration*.

*Alterations* shall not create an unsafe or hazardous condition or overload *existing* building systems. *Alterations* shall be such that the existing *building* or structure does not use more energy than the existing building or structure prior to the *alteration*. *Alterations* to existing *buildings* shall comply with Sections R503.1.1 through R503.1.4.

**R503.1.1 Building envelope.** Building envelope assemblies that are part of the *alteration* shall comply with Section R402.1.2 or R402.1.4, Sections R402.2.1 through ~~R402.2.15~~, R402.2.12, R402.3.1, R402.3.2, ~~R402.4.4~~ R402.4.3 and ~~R402.4.6~~ R402.4.5.

**Exception:** The following alterations to conditioned spaces shall not be required to comply with the requirements for new construction provided that the energy use of the building is not increased:

1. Storm windows installed over existing fenestration.
2. Existing ceiling, wall or floor cavities exposed during construction provided that these cavities are filled with insulation. ~~Roof systems requiring air space for ventilation shall retain the ventilation space required.~~
3. Construction where the existing roof, wall or floor cavity is not exposed.
4. ~~Roof recover, and roof replacement such that the existing building or structure is no less conforming to the provisions of this code than the existing building or structure was prior to the alteration.~~
5. ~~Deleted~~
5. Roofs without insulation in the cavity and where the sheathing or insulation is exposed during reroofing shall be insulated either above or below the sheathing.
6. Surface-applied window film installed on existing single pane fenestration assemblies to reduce solar heat gain provided that the code does not require the glazing or fenestration assembly to be replaced.
7. ~~Converting unconditioned attic space to conditioned attic space for one and two family dwellings and townhouses. Ceilings shall be insulated to a minimum of R-30, walls shall be insulated to the exterior wall requirements in Table R402.1.2 or Table R402.1.4 and follow the backing requirements in Sections R402.2.14 and R402.2.15.~~

**R503.1.1.1 Replacement fenestration.** ~~Where an entire existing fenestration unit is replaced with a new fenestration product, including frame, sash and glazing, the replacement fenestration unit shall meet the applicable requirements for U factor and SHGC in Table R402.1.2.~~

**Exception:** ~~Alterations that replace less than 50 percent of entire fenestration units may be replaced with like or better fenestration units to match existing fenestration assemblies.~~

**R503.1.1.1 Replacement fenestration.** Where some or all of an existing fenestration unit is replaced with a new fenestration product, including sash and glazing, the replacement fenestration unit shall meet the applicable requirements for U-factor and SHGC as specified in Table R402.1.3. Where more than one replacement fenestration unit is to be installed, an area-weighted average of the U-factor, SHGC or both of all replacement fenestration units shall be an alternative that can be used to show compliance.

**R503.1.2 Heating and cooling systems.** ~~New heating, cooling and duct systems that are part of the alteration shall comply with Sections R403.1, R403.2, R403.3 R403.4, R403.6 and R403.7.~~

**Exception:** ~~An alteration involving a partial system replacement to an existing duct system shall not require a duct leakage test.~~

**R503.1.2 Heating and cooling systems.** HVAC ducts newly installed as part of an alteration shall comply with Section R403.

**Exception:** Where ducts from an existing heating and cooling system are extended to an addition.

**R503.1.3 Service hot water systems.** New service hot water systems that are part of the alteration shall comply with Section R403.5.

**R503.1.4 Lighting.** New lighting systems that are part of the alteration shall comply with Section R404.1.

**Exception:** *Alterations* that replace less than ~~50~~ 10 percent of the luminaires in a space, provided that such alterations do not increase the installed interior lighting power.

**R503.2 Change in space conditioning.** ~~New work performed shall meet the requirements of this code. Projects changing unconditioned space to conditioned space and costing more than \$10,000 shall require 10 percent of the project cost to be used toward meeting the requirements of Chapter 11 of the North Carolina Residential Code for one and two family dwellings and townhouses or the North Carolina Energy Conservation Code. Project costs for the purpose of this section is the total project cost listed on all permits related to the work required to convert the unconditioned space to conditioned space and excludes the~~

~~10 percent added from this section. Under this section, existing building envelope elements that become a part of the building thermal envelope and are not changed are not required to be upgraded. The additional 10 percent of the project cost shall be appropriated for additional energy conservation features of choice that are addressed in Chapter 11 of the *North Carolina Residential Code* for one and two family dwellings and townhouses or the *North Carolina Energy Conservation Code*. In addition to the 10 percent project cost, any existing wall, ceiling, or floor cavities that are exposed during construction shall at a minimum be insulated to comply with Chapter 11 of the *North Carolina Residential Code* for one and two family dwellings and townhouses or the *North Carolina Energy Conservation Code* or be insulated to fill the cavity, whichever is less. Roof systems requiring air space for ventilation shall retain the ventilation space required. Projects costing less than \$10,000 are not subject to the 10 percent project cost addition provision.~~

## SECTION R504 REPAIRS

~~**R504.1 General.** Repair of the building systems shall not make the building less conforming than it was before the repair was undertaken. Buildings, structures and parts thereof shall be repaired in compliance with Section R501.3 and this section. Work on nondamaged components necessary for the required *repair* of damaged components shall be considered to be part of the *repair* and shall not be subject to the requirements for *alterations* in this chapter. Routine maintenance required by Section R501.3, ordinary repairs exempt from *permit*, and abatement of wear due to normal service conditions shall not be subject to the requirements for *repairs* in this section.~~

~~**R504.2 Materials.** Portions of walls that are part of the building thermal envelope shall be insulated in accordance with this code when the repair requires the removal of either the interior or exterior wall membrane such that the wall cavity is exposed during the repair.~~

~~**Exception:** Wall cavities containing existing insulation material.~~

~~**R504.2 Application.** For the purposes of this code, the following shall be considered to be *repairs*:~~

- ~~1. Glass-only replacements in an existing sash and frame.~~
- ~~2. Roof *repairs*.~~
- ~~3. *Repairs* where only the bulb, ballast or both within the existing luminaires in a space are replaced provided that the replacement does not increase the installed interior lighting power.~~

~~**R504.3 Glazing.** Repairs requiring the replacement of individual glass panes or sashes shall not require compliance with this code.~~

## SECTION R505 CHANGE OF OCCUPANCY OR USE

~~**R505.1 General.** New work performed in spaces undergoing a change in occupancy shall comply with the requirements of this code. Unaltered portions of the existing building or building supply system shall not be required to comply with this code.~~

~~**R505.1 General.** Any space that is converted to a dwelling unit or portion thereof from another use or occupancy shall comply with this code.~~

~~**Exception:** Where the simulated performance option in Section R405 is used to comply with this section, the annual energy cost of the *proposed design* is permitted to be 110 percent of the annual energy cost allowed by Section R405.2.~~

~~**R505.1.1 Unconditioned space.** Any unconditioned or low-energy space that is altered to become a *conditioned space* shall comply with Section R502.~~

## CHAPTER 6 [RE] REFERENCED STANDARDS

---

### **AAMA**

American Architectural Manufacturers Association  
1827 Walden Office Square  
Suite 550  
Schaumburg, IL 60173-4268

AAMA/WDMA/CSA 101/I.S.2/A C440—11

AAMA/WDMA/CSA 101/I.S.2/A C440—17

North American Fenestration Standard/Specifications for Windows, Doors and Unit Skylights  
R402.4.4

---

### **ACCA**

Air Conditioning Contractors of America  
1330 Braddock Place, Suite 350  
Alexandria, VA 22314

ANSI/ACCA 2 Manual J—16

Residential Load Calculation  
R403.7

ANSI/ACCA 3 Manual S—14

Residential Equipment Selection  
R403.7

---

### **APSP**

Pool & Tub Alliance (formerly the APSP)  
2111 Eisenhower Avenue, Suite 500

Alexandria, VA 22314

ANSI/APSP/ICC 14—2019

American National Standard for Portable Electric Spa Energy Efficiency  
R403.11

ANSI/APSP/ICC 15a—2013

ANSI/APSP/ICC 15a—2011

American National Standard for Residential Swimming Pool and Spas—Includes Addenda A Approved January 9, 2013  
R403.12

---

### **ASHRAE**

ASHRAE  
180 Technology Parkway NW

ASHRAE 193—2010(RA 2014)

Method of Test for Determining the Airtightness of HVAC Equipment

R403.3.4.1

**ASHRAE—2001**

**2001 ASHRAE Handbook of Fundamentals**

Table R405.5.2(1)

**ASHRAE—2013**

**ASHRAE—2021**

**ASHRAE Handbook of Fundamentals**

R402.1.5

---

# ASTM

ASTM International  
100 Barr Harbor Drive, P.O. Box C700  
West Conshohocken, PA 19428-2959

**C1363—11**

**Standard Test Method for Thermal Performance of Building Materials and Envelope Assemblies by Means of a Hot Box Apparatus**

R303.1.4.1

**E283—2004**

**E283—2004(2012)**

**Test Method for Determining the Rate of Air Leakage Through Exterior Windows, Curtain Walls and Doors Under Specified Pressure Differences Across the Specimen**

R402.4.4

**E779—2010**

**E779—2010(2018)**

**Standard Test Method for Determining Air Leakage Rate by Fan Pressurization**

R402.4.1.2

**E1554/E1554M—E2013**

**Standard Test Methods for Determining Air Leakage of Air Distribution Systems by Fan Pressurization**

R403.3.5

**E1827—2011**

**E1827—2011(2017)**

**Standard Test Methods for Determining Airtightness of Building Using an Orifice Blower Door**

R402.4.1.2

**E2178—2013**

**Standard Test Method for Air Permanence of Building Materials**

R303.1.5

---

# CSA

CSA Group  
8501 East Pleasant Valley Road  
Cleveland, OH 44131-5516

~~AAMA/WDMA/CSA 101/LS.2/A440—11~~

AAMA/WDMA/CSA 101/LS.2/A440—17

North American Fenestration Standard/Specification for Windows, Doors and Unit Skylights R402.4.3

CSA B55.1—2015

Test Method for Measuring Efficiency and Pressure Loss of Drain Water Heat Recovery Units

R403.5.3

CSA B55.2—2015

Drain Water Heat Recovery Units

R403.5.3

---

## DASMA

Door & Access Systems Manufacturers Association  
1300 Sumner Avenue  
Cleveland, OH 44115-2851

~~105—92(R2004)-13~~

105—2017

Test Method for Thermal Transmittance and Air Infiltration of Garage Doors and Rolling Doors

R303.1.3

---

## HVI

Home Ventilating Institute  
1740 Dell Range Blvd, Ste H, PMB 450  
Cheyenne, WY 82009

916—18

Airflow Test Procedure Table R403.6.2

---

## ICC

Washington, DC 20001

International Code Council, Inc.  
500 New Jersey Avenue NW 6th Floor

ANSI/APSP/ICC 14—2019

American National Standard for Portable Electric Spa Energy Efficiency

R403.11

ANSI/APSP/ICC 15a—2020

American National Standard for Residential Swimming Pool and Spa Energy Efficiency

R403.12

ANSI/RESNET/ICC 301—14

ANSI/RESNET/ICC 301—2019

Standard for the Calculation and Labeling of the Energy Performance of Dwelling and Sleeping Units using an Energy Rating Index

R406.4

ICC—continued

**ANSI/RESNET/ICC 380—2019**

**Standard for Testing Airtightness of Building, Dwelling Unit and Sleeping Unit Enclosures; Airtightness of Heating and Cooling Air Distribution Systems, and Airflow of Mechanical Ventilation Systems**

R402.4.1.2

**IBC—21**

**International Building Code®**

R201.3, R303.1.1, R303.2, R402.1.1, R501.4

**ICC 400—17**

**Standard on the Design and Construction of Log Structures**

R402.1

**ICC 500—2020**

**ICC/NSSA Standard for the Design and Construction of Storm Shelters**

R402.5

**~~IEBC—15~~**

**IEBC—21**

**International Existing Building Code®**

R501.4

**IECC—06**

**2006 International Energy Conservation Code®**

R202

**IECC—09**

**2009 International Energy Conservation Code®**

R406.2

**IECC—15**

**2015 International Energy Conservation Code®**

Table R406.5

**~~IFC—15~~**

**IFC—21**

**International Fire Code®**

R201.3, R501.4

**~~IFGC-15~~**

**IFGC—21**

**International Fuel Gas Code®**

R201.3, R501.4

**~~IMC—15~~**

**IMC—21**

**International Mechanical Code®**

R201.3, R403.3.3, R403.3.4, R403.6, R501.4

**~~IPC—15~~**

**IPC—21**

**International Plumbing Code®**

R201.3, R501.4

**IPMC—21**

**International Property Maintenance Code®**

R501.4

**IPSDC—21**

**International Private Sewage Disposal Code®**

R501.4

**IRC—15**

**IRC—21**

**International Residential Code®**

R201.3, R303.1.1, R303.2, R402.1.1, R402.2.10.1, R403.3.3, R403.3.4, R403.6, R501.4

---

**IEEE**

Institute of Electrical and Electronics Engineers, Inc.

3 Park Avenue, 17th Floor

New York, NY 10016-5997

**515.1—2012**

**IEEE Standard for the Testing, Design, Installation and Maintenance of Electrical Resistance Trace Heating for Commercial Applications**

R403.5.1.2

---

**NEMA**

**OS 4-2016 Requirements for Air-Sealed Boxes for Electrical and Communication Applications R402.4.6**

**NFPA**

National Fire Protection Association

1 Batterymarch Park

Quincy, MA 02169-7471

**70—20**

**National Electrical Code**

R501.4

---

**NFRC**

National Fenestration Rating Council, Inc.

6305 Ivy Lane, Suite 140

Greenbelt, MD 20770

**100—2009**

**100—2020**

**Procedure for Determining Fenestration Products *U*-factors**

R303.1.3

**200—2009**

**200—2020**

**Procedure for Determining Fenestration Product Solar Heat Gain Coefficients and Visible Transmittance at Normal Incidence**

R303.1.3

**400—2009**

**400—2020**



Procedure for Determining Fenestration Product Air Leakage  
R402.4.3

---

## **RESNET**

Residential Energy Services Network, Inc.  
P.O. Box 4561  
Oceanside, CA 92052-4561

**ANSI/RESNET/ICC 301—2019**

**Standard for the Calculation and Labeling of the Energy Performance of Dwelling and Sleeping Units using an Energy Rating Index**  
R406.4, R406.7.1, R406.7.6

**ANSI/RESNET/ICC 380—2019**

**Standard for Testing Airtightness of Building, Dwelling Unit and Sleeping Unit Enclosures; Airtightness of Heating and Cooling Air Distribution Systems, and Airflow of Mechanical Ventilation Systems**  
R402.4.1.2, R403.3.5

---

## **UL**

UL LLC  
333 Pfingsten Road  
Northbrook, IL 60062

**127—2011**

**Standard for Factory-Built Fireplaces—with Revisions through July 2016**  
R402.4.2

**515—2015**

**Standard for Electrical Resistance Trace Heating for Commercial Applications**  
R403.5.1.2

---

## **US-FTC**

United States-Federal Trade Commission  
600 Pennsylvania Avenue NW  
Washington, DC 20580

**CFR Title 16 (May 31, 2005)**

**CFR Title 16 (2015)**

**R-value Rule**

R303.1.4

---

## **WDMA**

Window and Door Manufacturers Association  
2025 M Street NW, Suite 800  
Washington, DC 20036-3309

**AAMA/WDMA/CSA 101/LS.2/A440—11**

**AAMA/WDMA/CSA 101/LS.2/A440—17**

**North American Fenestration Standard/Specification for Windows, Doors and Unit Skylights**  
R402.4.4

---

**APPENDIX R1**  
**RESIDENTIAL REQUIREMENTS**  
*(Appendix exclusive to the State of North Carolina)*

**Appendix R1.1** Energy Efficiency Certificate (Section R401.3)

**TABLE R401.3**  
**ENERGY EFFICIENCY CERTIFICATE – 2018 To be deleted**

Builder, Permit Holder or Registered Design Professional	
Print Name:	
Signature:	
Property Address:	
Date:	
<b>Insulation Rating – List the value covering largest area to all that apply</b>	
	<i>R-Value</i>
Ceiling/roof:	R-
Wall:	R-
Floor:	R-
Closed crawl space wall:	R-
Closed crawl space floor:	R-
Slab:	R-
Basement wall:	R-
<b>Fenestration:</b>	
U-Factor	
Solar Heat Gain Coefficient (SHGC)	
<b>Building Air Leakage</b>	
<input type="checkbox"/> Visually inspected according to R402.4.2.1 OR	
<input type="checkbox"/> Building air leakage test results (Sec. R402.4.2.2) ACH50 [Target: 5.0] or CFM50/SFSA [Target: 0.30]	
Name of Tester/Company:	
Date:	Phone:
<b>Ducts:</b>	
Insulation	R-
Total duct leakage test result (Sect. R403.3.3) Circle one: Total duct leakage test (CFM25 Total/100SF) [Target: 5] Or Duct leakage to the outside test (CFM25 Total/100SF) [Target: 4]	
Name of Tester or Company:	
Date:	Phone:
<b>Certificate to be displayed permanently</b>	

**TABLE R401.3**  
**ENERGY EFFICIENCY CERTIFICATE – 2024 Shown below**

<b>Energy Efficiency Certificate – Code Edition Permitted under: _____</b>	
<b>Energy Code Compliance path used (Circle one): 1.Prescriptive 2.Total Building Performance 3.ERI</b>	
Builder, Permit Holder or Registered Design Professional: Print Name: Signature:	
Property Address:	
Date:	
<b>Insulation Rating – List the value covering largest area to all that apply</b>	<b>R-value</b>
Ceiling/roof:	R-
Wall:	R-
Floor:	R-
Closed crawl space wall:	R-
Closed crawl space floor:	R-
Slab:	R-
Basement wall:	R-
<b>Fenestration</b>	
Fenestration (excluding skylights)	U-            U <sub>w.a.</sub> -
Fenestration (Skylights)	U-            U <sub>w.a.</sub> -
Solar Heat Gain Coefficient (SHGC)(All glazed fenestration)	SHGC -      SHGC <sub>w.a.</sub> -
<b>Building Air Leakage</b>	
Building air leakage test results (See N1102.4.1.2, R402.4.1.2) Target value: 4.0 ACH@50; or see N1102.4 (R402.4.1.2) for alternate test pressures and leakage allowance values.	
Name of Tester/Company:	
Date of test:	Phone:
<b>Ducts:</b>	
Insulation	R-
Total Duct leakage test result (N1103.3.6, R403.3.6) Target value: 4.0 CFM per 100 sq. ft. of conditioned floor area, at test pressure of 0.1 inch of w.g. (25 Pascals); or 8.0 CFM per 100 sq. ft. of conditioned floor area, at test pressure of 0.1 inch of w.g. (25 Pascals) if all ductwork is within building thermal envelope	
Name of Tester or Company:	
Date of Test:	Phone:
<b>Heating/Cooling Equipment</b>	
Type(s):	
Size(s) Btu/hr:	Fuel-fired Efficiency:            Heat pump and/or AC SEER, HSPF:
<b>Water heating</b>	
Type(s)	
Size(s) (Watts or Btu/hr):	Fuel fired efficiency:            Heat pump Water heater COP:
Where a gas-fired unvented room heater, electric furnace or baseboard electric heater is installed in the residence, the certificate shall indicate “ <b>gas-fired unvented room heater,</b> ” “ <b>electric furnace</b> ” or “ <b>baseboard electric heater,</b> ” as appropriate:	

**Energy Rating Index:**

If, and only if the ERI pathway was used, write the ERI Score:

Without On-Site generation:

With On-Site generation (if applicable):

**Certificate to be displayed permanently-** per N1101.14 (R401.3)

**APPENDIX R1.2  
INSULATION AND AIR SEALING DETAILS**

**APPENDIX R1.2.1 (Section R402.2.1)**

R402.2.1 Ceilings with attic spaces: Exception for fully enclosed attic floor systems.

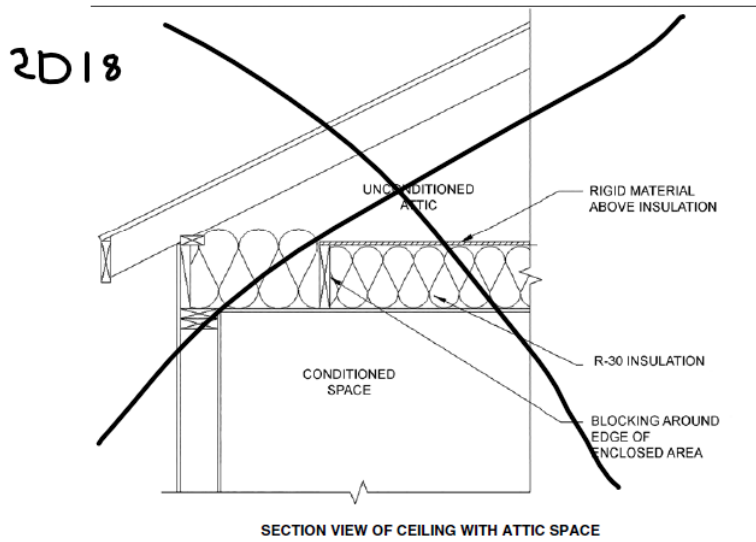

**APPENDIX R1.2.1 (Section R402.2.1) [ 2024]**

**R402.2.1 Ceilings with attic spaces:** Allowance for reduced insulation if full-height insulation is provided over the wall top plate at the eaves.

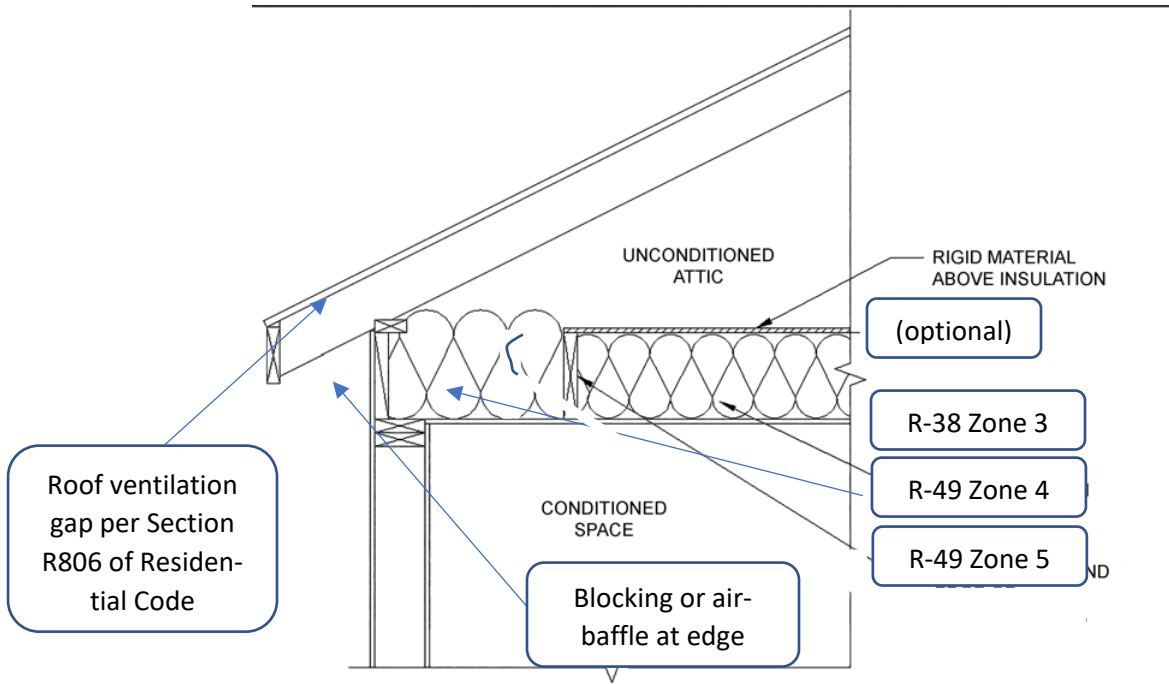

**R402.2.1 Ceilings with attic spaces:** Allowance for reduced insulation if full-height insulation is provided over the walls eaves – Optional method, Formerly “Fully enclosed enclosed attic floor assembly-2018 NC ECC”

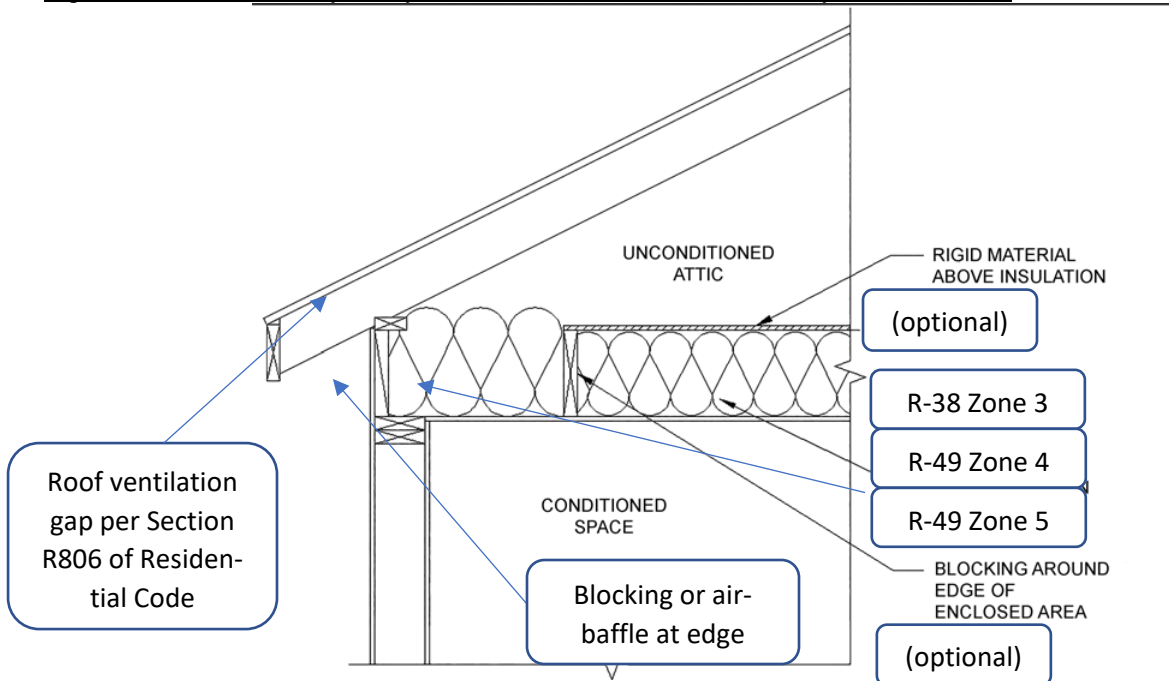

**R402.2.1 Ceilings with attic spaces:** Exception for fully enclosed attic floor systems.

**APPENDIX R1.2.2 (Section R402.2.11 R402.2.10)**

**R402.2.11 R402.2.10 Closed crawl space walls. Insulation illustrations.** [Note to Reviewer – No Changes in diagram]

FOAM OR POROUS INSULATION HAS 3" TO 4" TOP INSPECTION GAP AND EXTENDS DOWN 3" TO 4" ABOVE TOP OF WALL FOOTING OR CONCRETE FLOOR

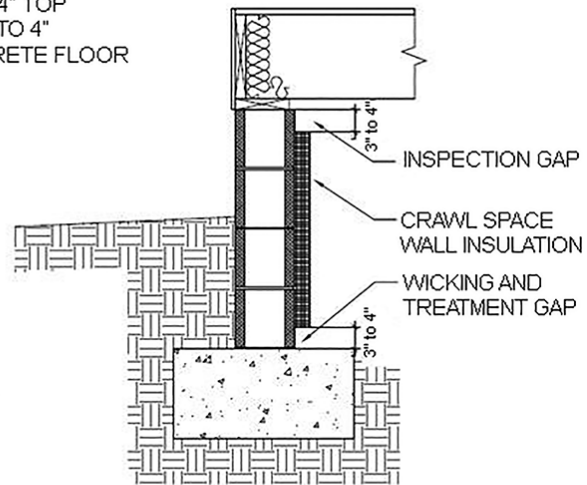

FOAM OR POROUS INSULATION HAS 3" TO 4" TOP INSPECTION GAP AND EXTENDS DOWN 24" BELOW GRADE

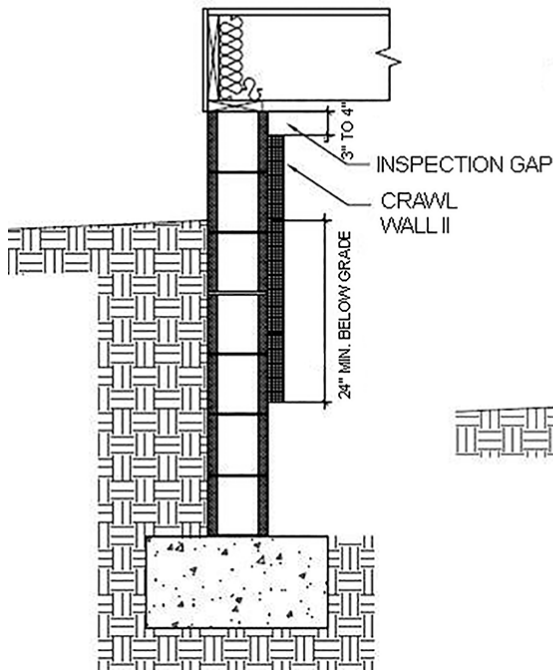

FOAM OR POROUS INSULATION HAS 3" TO 4" TOP INSPECTION GAP AND EXTENDS DOWN 3" TO 4" ABOVE INTERIOR GROUND SURFACE

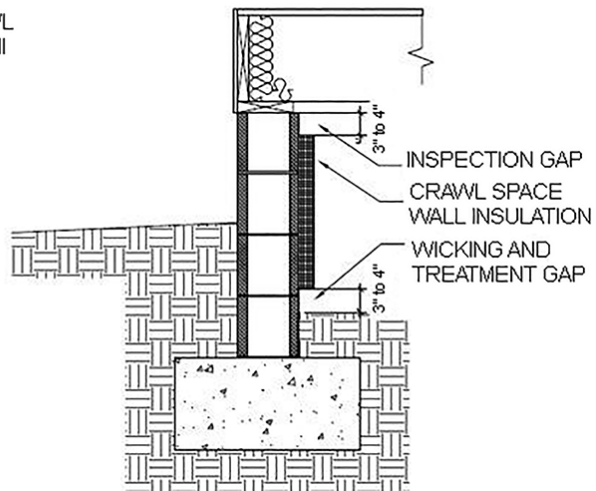

**APPENDIX R1.2.3 (Section R402.2.14 R402.4.1.1, Table R402.2.15 R402.4.1.1)**

**Table R402.2.14 R402.4.1.1 Air Barrier, Air Sealing and Insulation Installation. Shower/Tub on exterior wall**  
[Note to reviewer – no change to diagram]

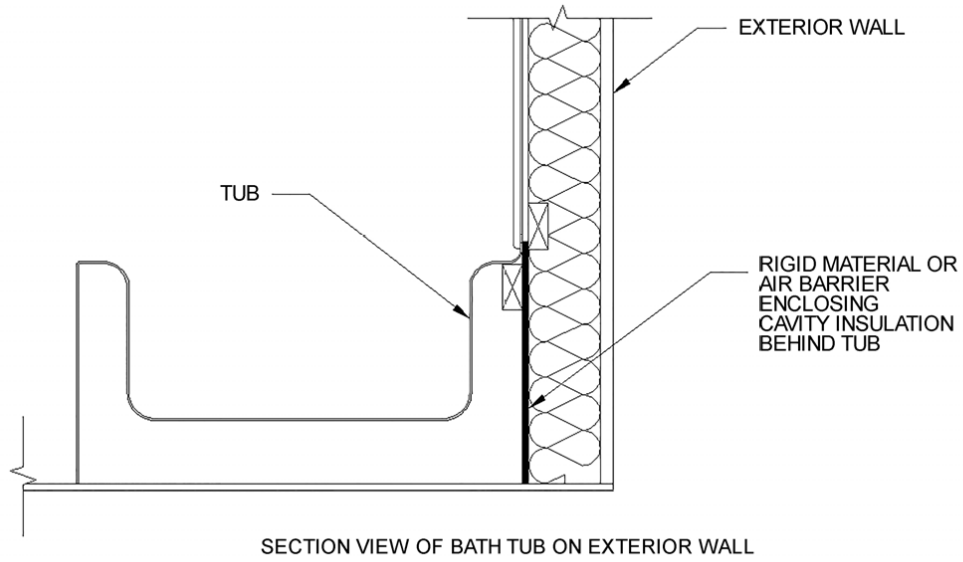



**R402.2.14 Table R402.4.1.1 Air Barrier, Air Sealing and Insulation Installation.** Shower/tub on exterior wall  
[Note to reviewer – no change to diagram]

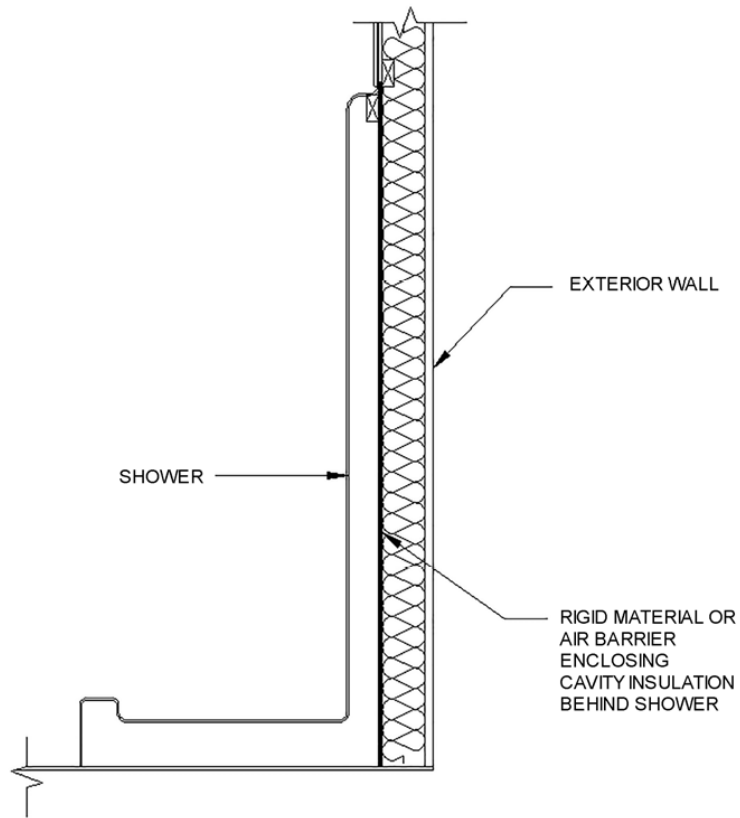

SECTION VIEW OF SHOWER ON EXTERIOR WALL

---

**R402.2.14 Table R402.4.1.1 Air Barrier, Air Sealing, and Insulation Installation – General Requirements**  
[Note to reviewer – no change to diagram]

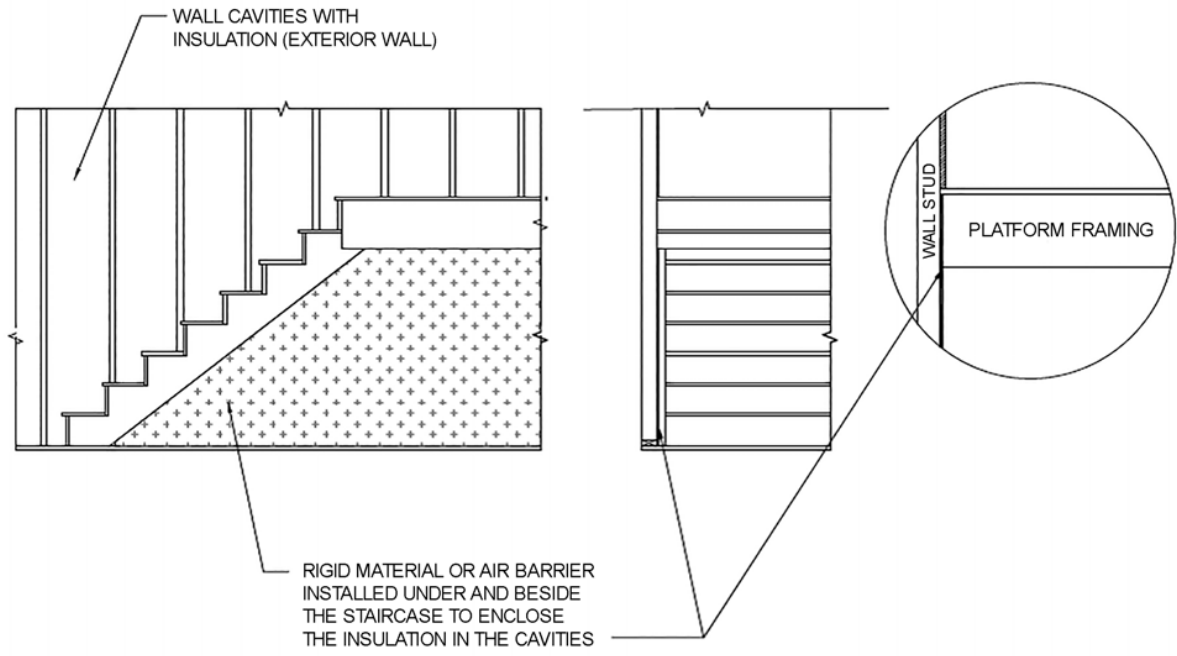

SECTION VIEW OF INTERIOR STAIRCASE ON EXTERIOR WALL (OPTION 1)

---

**R402.2.14 Table R402.4.1.1 Air Barrier, Air Sealing, and Insulation Installation – General Requirements**  
[Note to reviewer – no change to diagram]

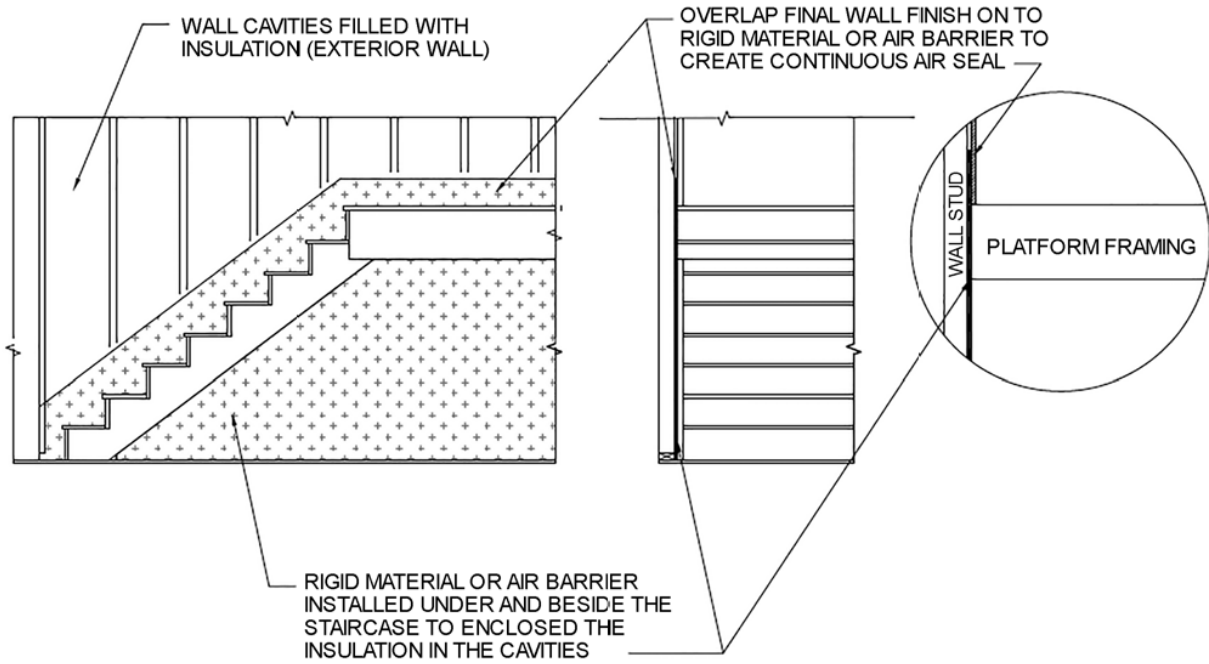

SECTION VIEW OF INTERIOR STAIRCASE ON EXTERIOR WALL (OPTION 2)

**R402.2.14 Table R402.4.1.1 Air Barrier, Air Sealing, and Insulation Installation – Shafts, penetrations. Flue Shaft.**  
[Note to reviewer – no changes to diagram]

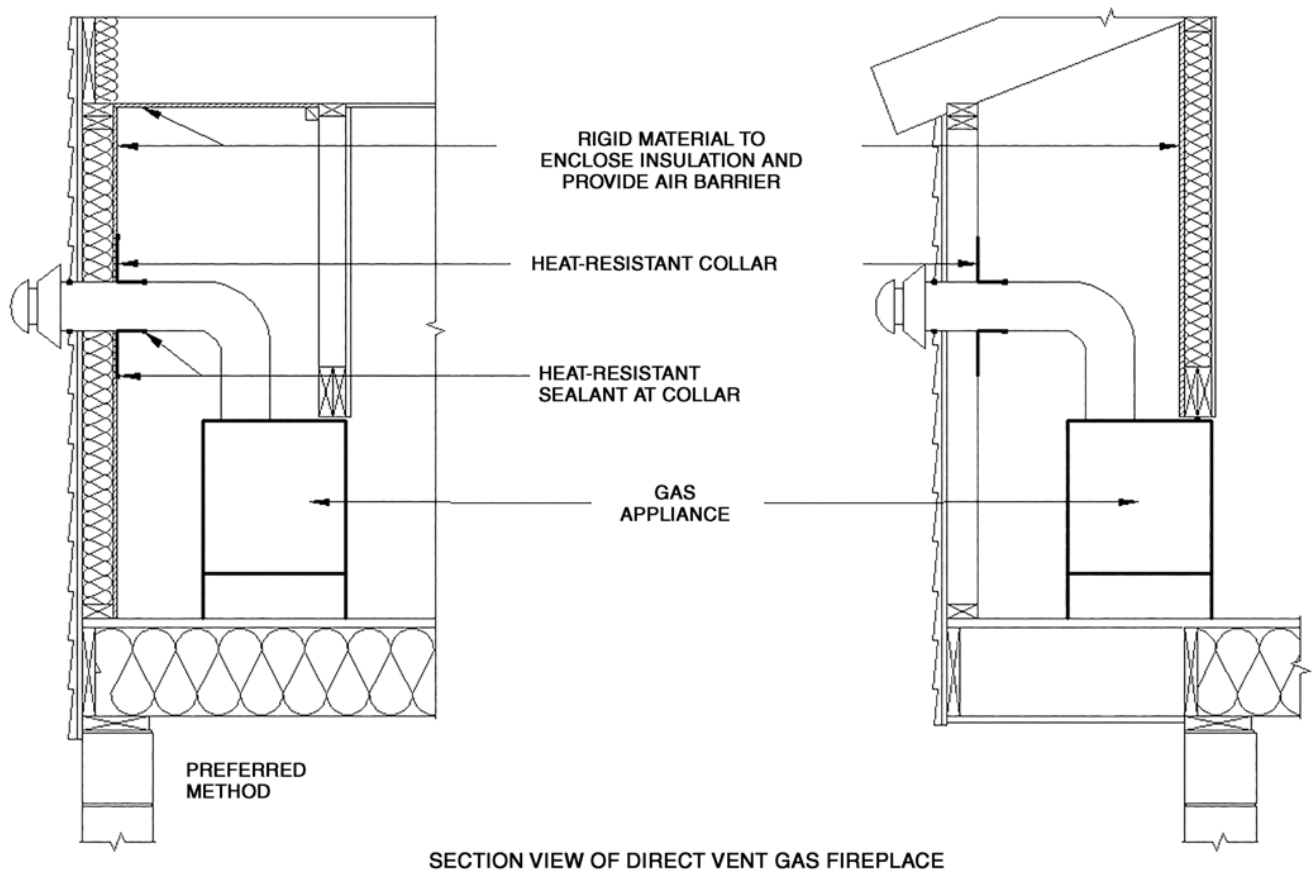

**R402.2.15 Table R402.4.1.1 Air Barrier, Air Sealing, and Insulation Installation – Walls, Knee walls, stick framed roof**

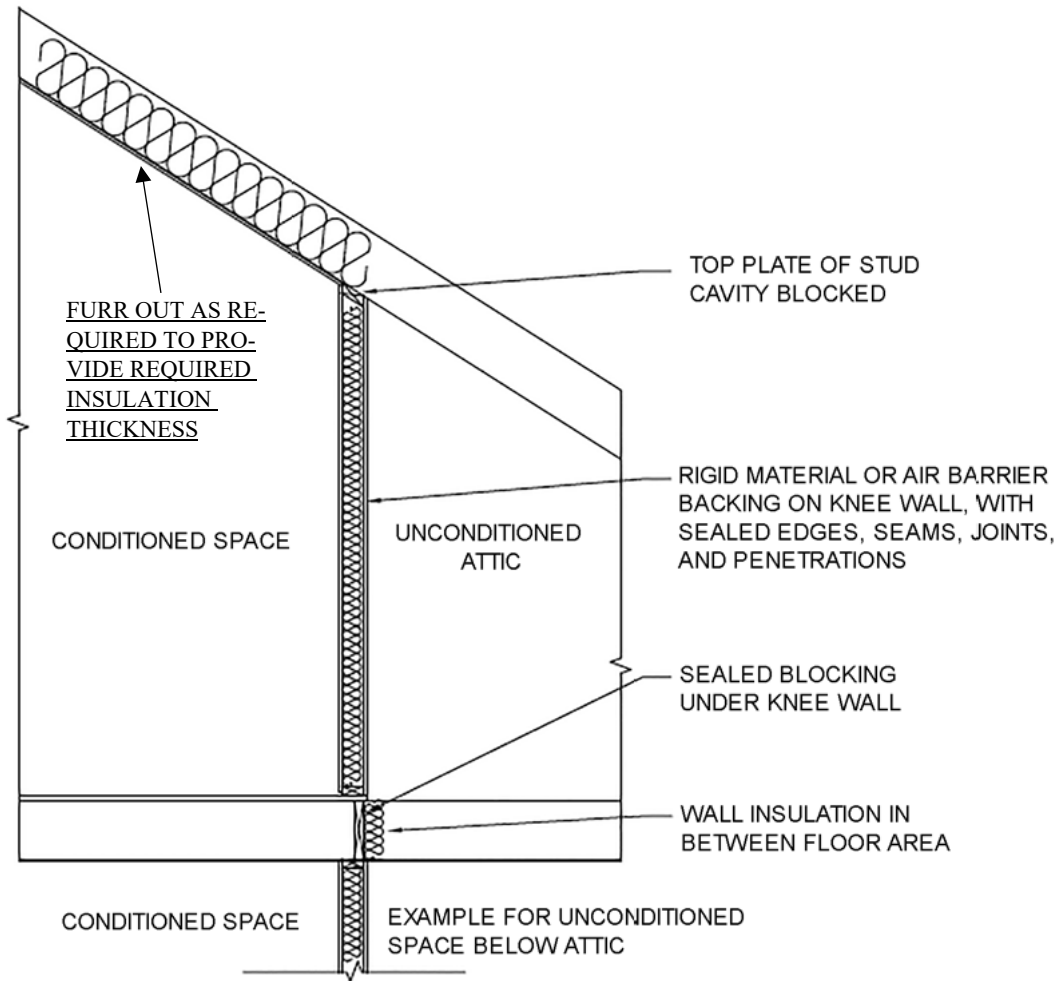

**SECTION VIEW OF WALL ADJOINING ATTIC SPACE WITH STICK FRAMED ROOF**

---

**R402.2.15 Table R402.4.1.1 Air Barrier, Air Sealing, and Insulation Installation – Walls, Knee walls, trusses**  
[Note to Reviewer – no change to diagram]

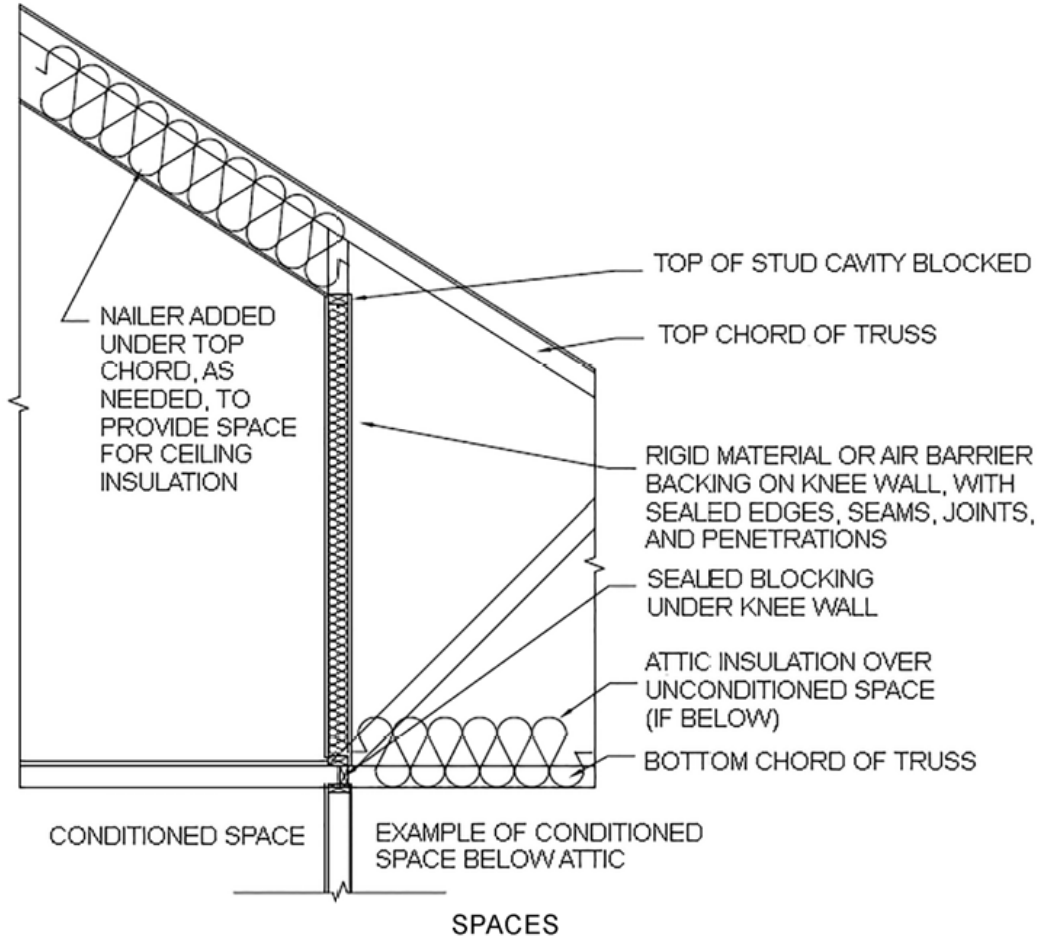

**SECTION VIEW OF WALL ADJOINING ATTIC SPACE WITH TRUSS ROOF**

---

---

**R402.4.1 Table R402.4.1.1 Air Barrier, Air Sealing, and Insulation Installation – Cantilevered floor – dimensional lumber**

[note to reviewer – diagram unchanged]

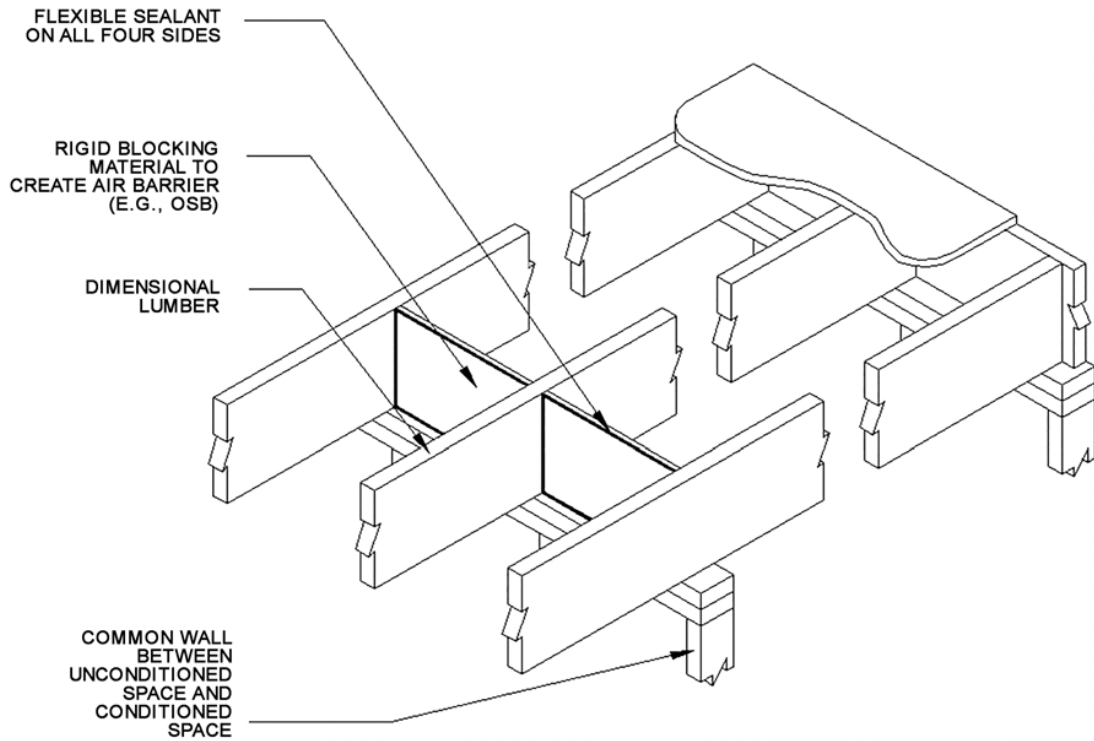

ISOMETRIC VIEW OF DIMENSIONAL LUMBER FLOOR/CEILING SYSTEM ABOVE COMMON WALL BETWEEN UNCONDITIONED AND CONDITIONED SPACE

**R402.4.1 Table R402.4.1.1 Air Barrier, Air Sealing, and Insulation Installation – Cantilevered floor – floor trusses**  
**[Note to reviewer – No Changes to Diagram]**

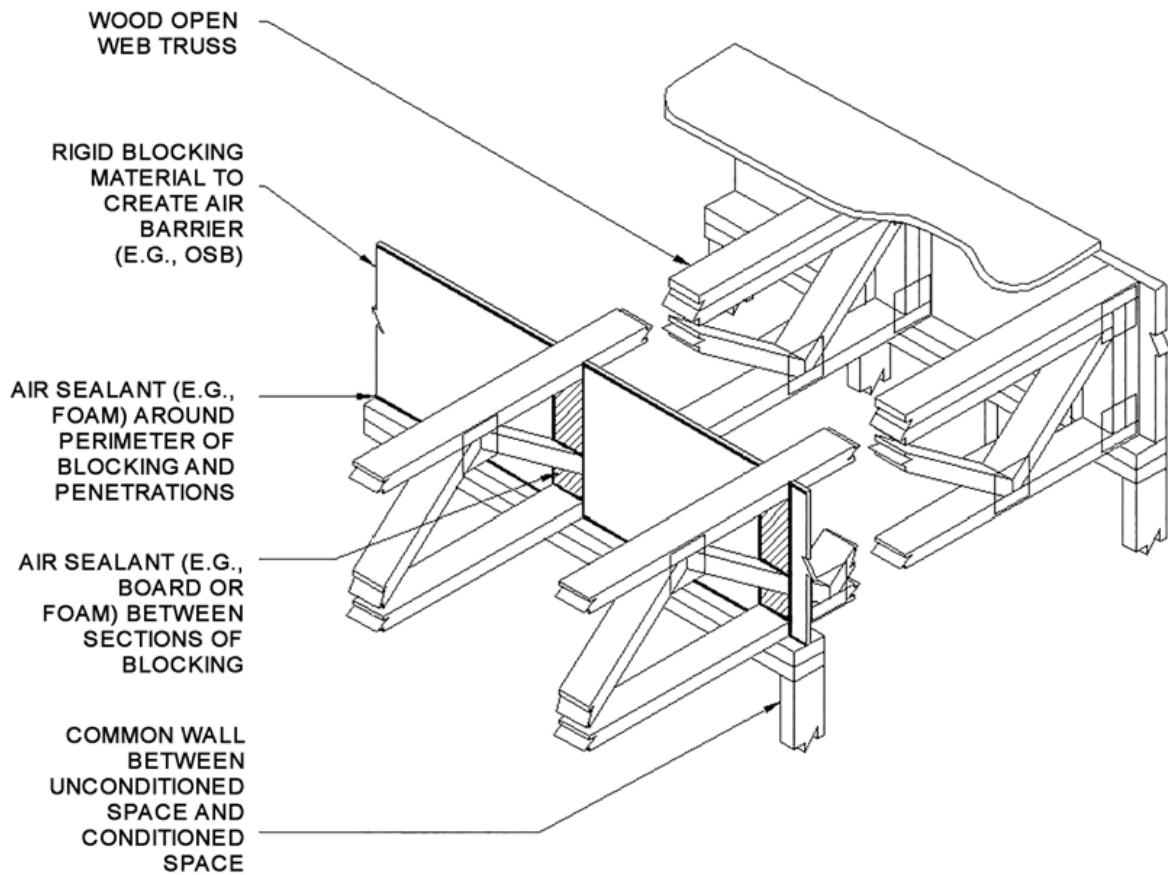

**ISOMETRIC VIEW OF WOOD TRUSS FLOOR/CEILING SYSTEM ABOVE  
COMMON WALL BETWEEN UNCONDITIONED AND CONDITIONED SPACE**

---



**R402.4.1 Table R402.4.1.1 Air Barrier, Air Sealing, and Insulation Installation – Cantilevered floor – I-joists**  
[Note to Reviewer diagram unchanged]

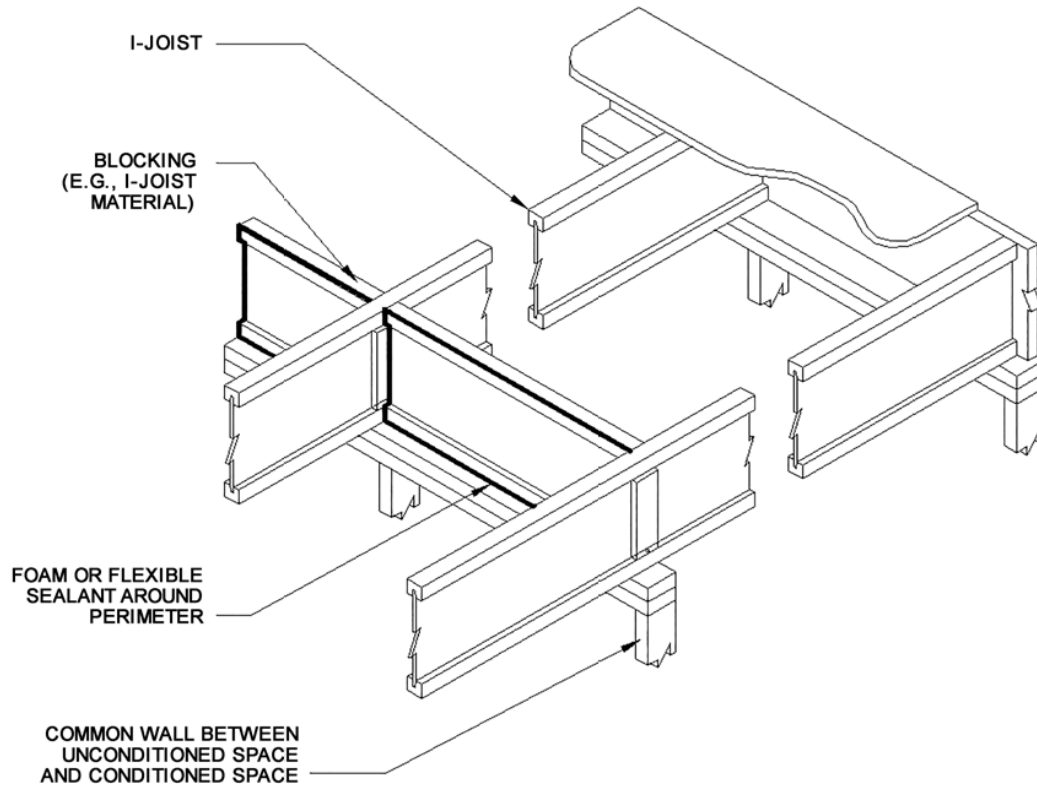

ISOMETRIC VIEW OF I-JOIST FLOOR/CEILING SYSTEM ABOVE COMMON  
WALL BETWEEN UNCONDITIONED AND CONDITIONED SPACE

---

---

**R402.4.1 Table R402.4.1.1 Air Barrier, Air Sealing, and Insulation Installation – Shafts, penetrations**  
[Note to Reviewer – diagram unchanged]

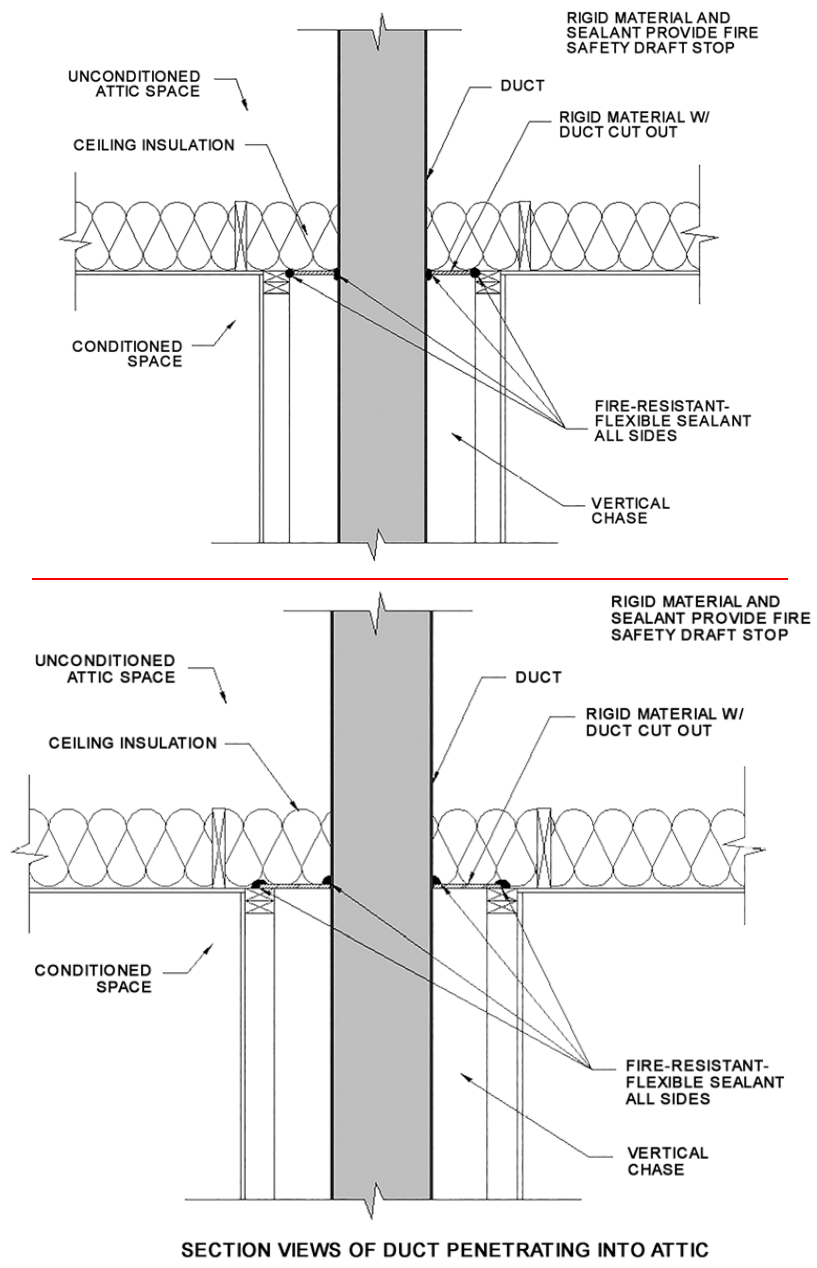

**R402.4.1 Table R402.4.1.1 Air Barrier, Air Sealing, and Insulation Installation – Ceiling/attic – dropped soffit**  
[Note to reviewer – diagram unchanged]

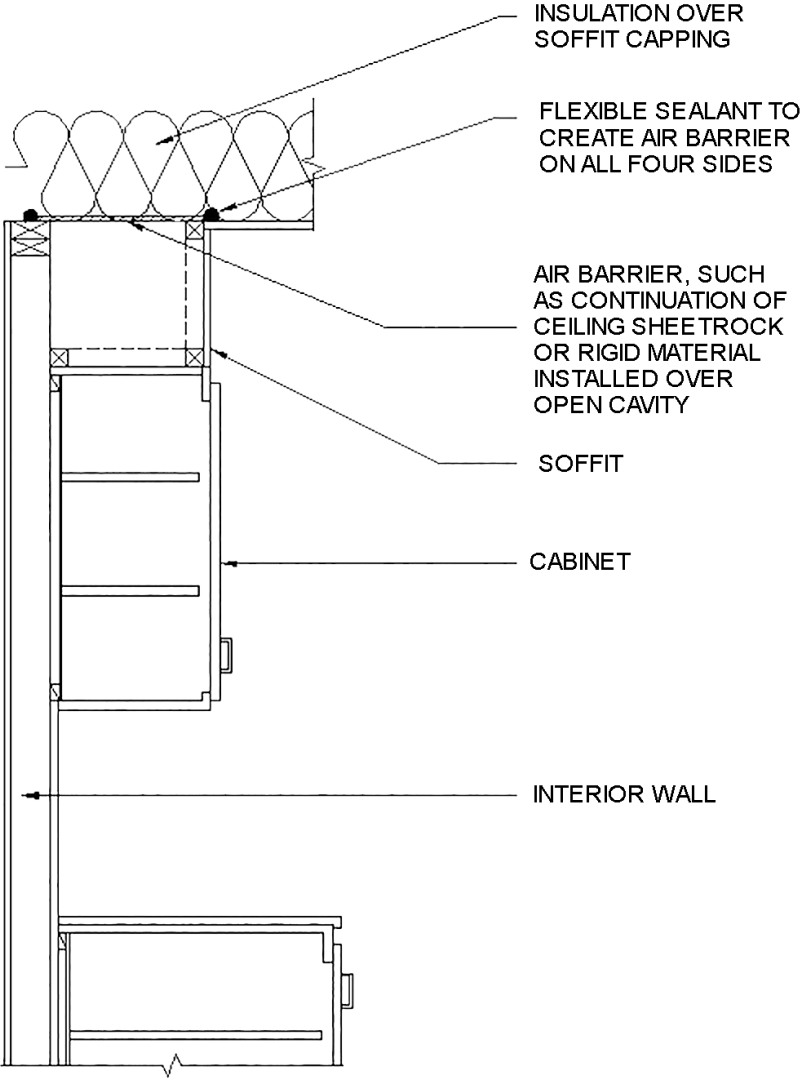

SECTION VIEW OF SOFFIT OVER CABINET

**R402.4.1 Table R402.4.1.1 Air Barrier, Air Sealing, and Insulation Installation – HVAC register boots – floor**  
[Note to reviewer – diagram unchanged]

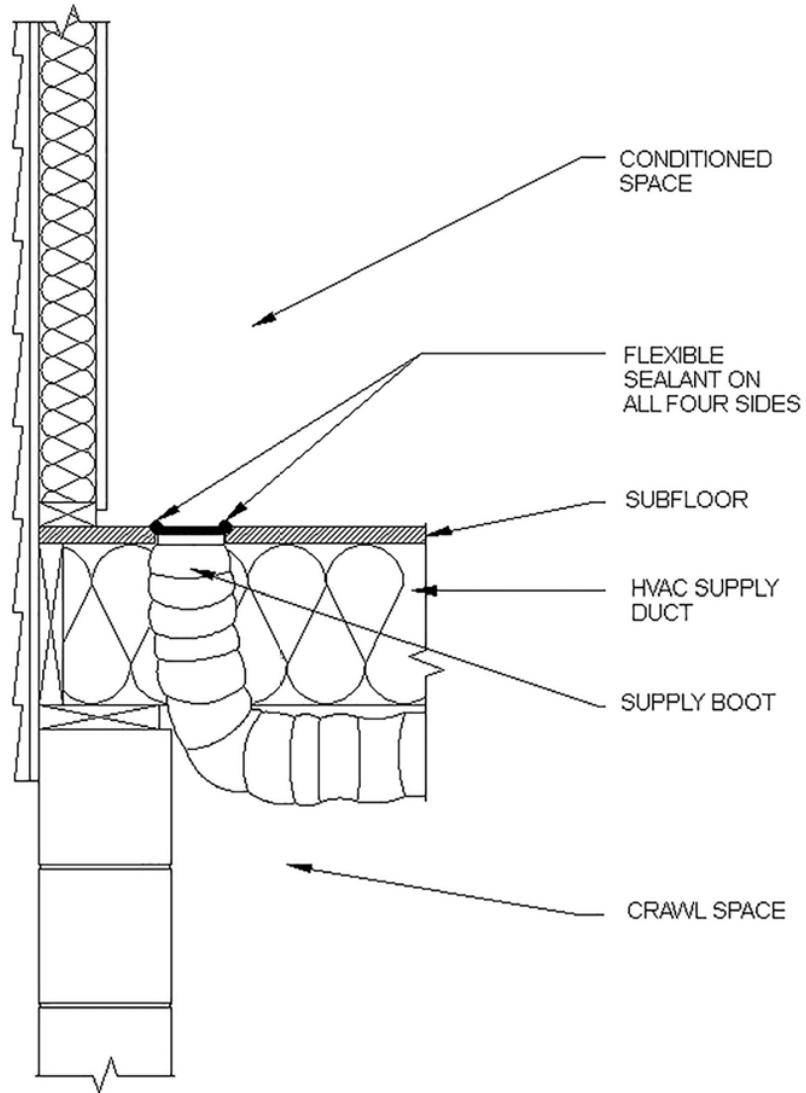

SECTION VIEW OF FLOOR HVAC BOOT PENETRATION

---

---

**R402.4.1 Table R402.4.1.1 Air Barrier, Air Sealing, and Insulation Installation – HVAC register boots – ceiling**  
[Note to reviewer – no changes to diagram]

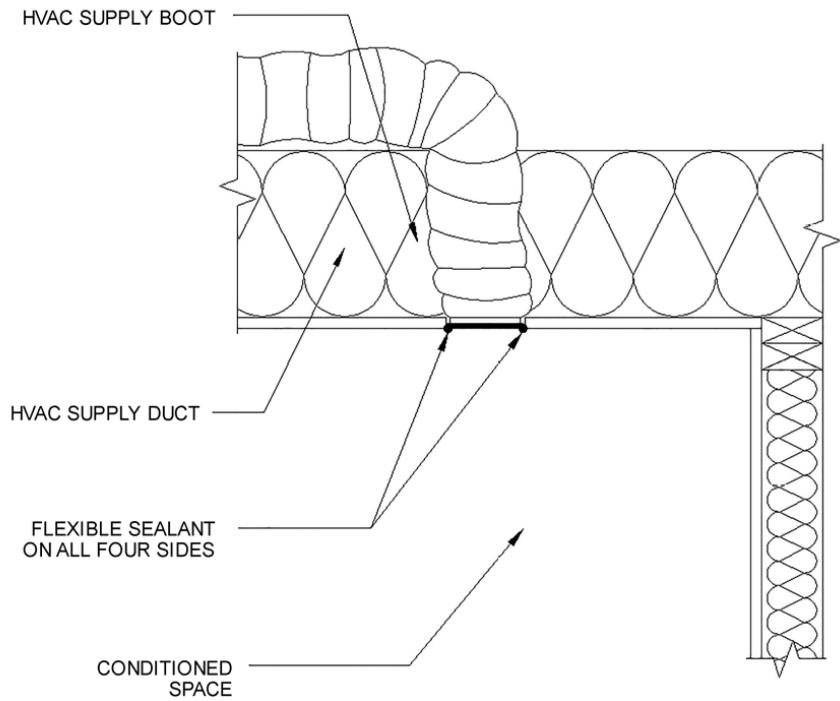

SECTION VIEW OF CEILING HVAC BOOT PENETRATION

**R402.4.1 Table R402.4.1.1 Air Barrier, Air Sealing, and Insulation Installation – General requirements – housewrap option**

[Note to Reviewer – diagram unchanged]

Follow manufacturer’s instructions for sealing air barrier-rated housewrap, including choice of materials, to provide an exterior air barrier at the following locations:

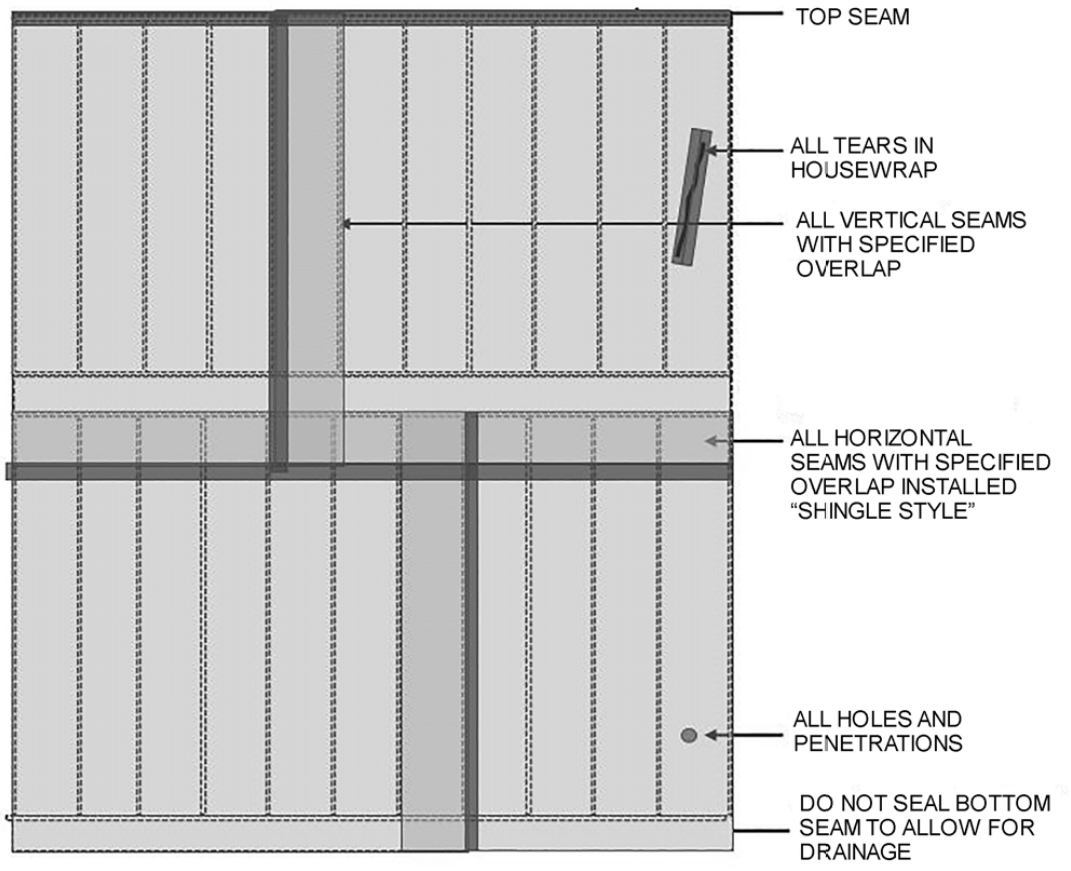

**R402.4.1 Table R402.4.1.1 Air Barrier, Air Sealing, and Insulation Installation – General requirements – sealed sheathing option**

[Note to reviewer – No changes to diagram]

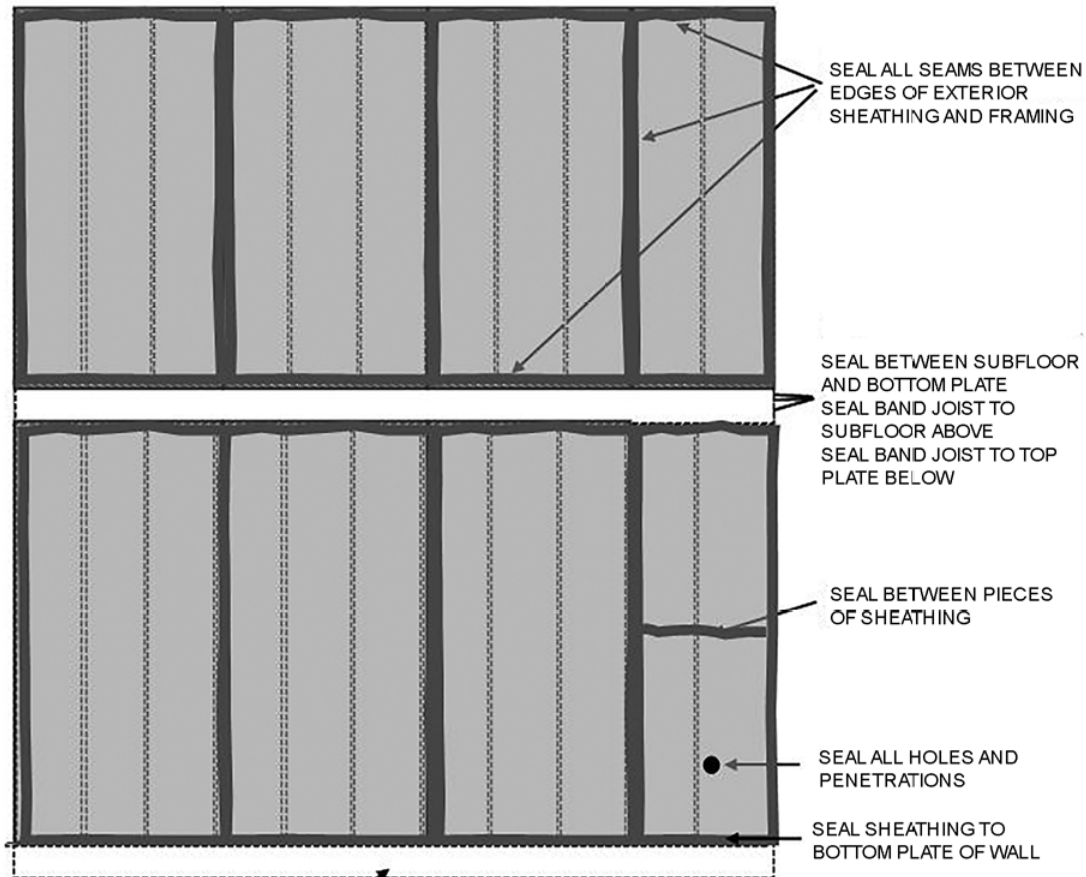

- 1) IF FIRST FLOOR IS SLAB-ON-GRADE, INSTALL SEAL SEALER UNDER BOTTOM PLATE OF EXTERIOR WALL.
- 2) IF FIRST FLOOR IS OVER UNCONDITIONED CRAWL SPACE OR BASEMENT, INSTALL SEAL SEALER UNDER BOTTOM PLATE AND SEAL SUBFLOOR TO BAND JOIST.
- 3) IF FIRST FLOOR IS OVER CONDITIONED BASEMENT OR CLOSED CRAWL SPACE WITH CRAWL SPACE WALL INSULATION BELOW, SEAL BETWEEN SUBFLOOR AND BOTTOM PLATE, SEAL BAND JOIST TO SUBFLOOR ABOVE, AND SEAL BAND JOIST TO TOP PLATE BELOW.

**R402.4.2.1 Table R402.4.1.1 Air Barrier, Air Sealing, and Insulation Installation – Plumbing, wiring, or other obstructions – Exhaust fan**  
[Note to Reviewer - Diagram unchanged]

**R402.4.2.1 Visual inspection option.** ~~Table R402.4.2 Seal ceiling mechanical box penetrations~~

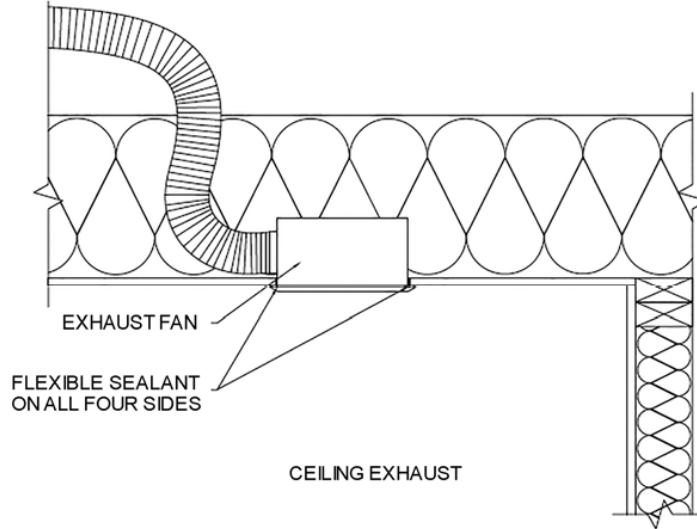

SECTION VIEW OF SEALING EXHAUST FAN BOXES

---

**R402.4.2.1 R402.4.6 Electrical and communication outlet boxes – field-sealed**

**R402.4.2.1 Visual inspection option.** ~~Table R402.4.2 Seal ceiling electrical box penetrations~~

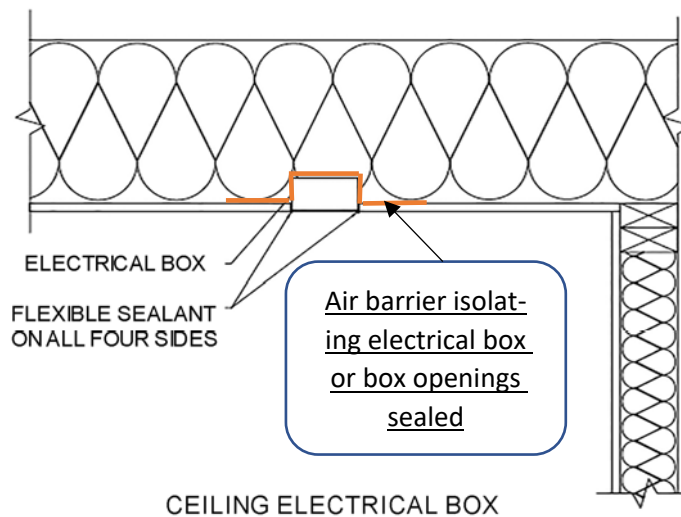

CEILING ELECTRICAL BOX

---



**R402.4.6 Electrical and communication outlet boxes – NEMA OS 4**

**R402.4.2.1 Visual inspection option.** Table R402.4.2 Seal ceiling electrical box penetrations

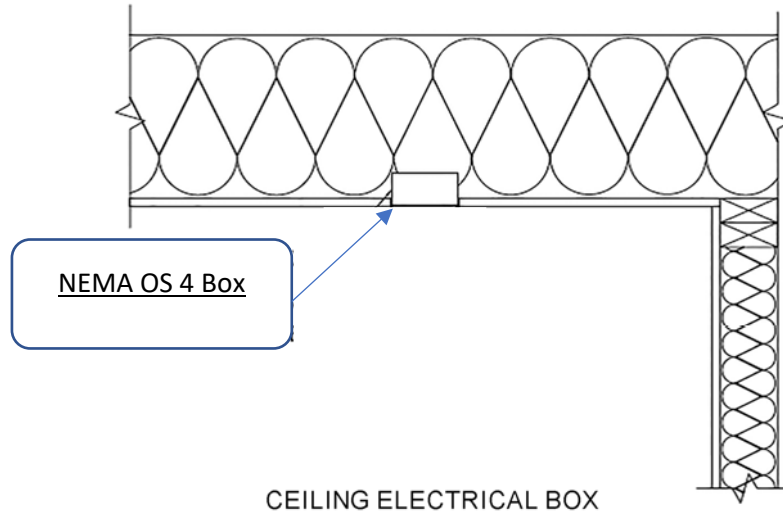

**APPENDIX R2**  
**FOAM PLASTIC DIAGRAMS**  
**(Sections R402.2.9 and R402.2.10)**

**R402.2.9 Basement walls.** Insulation illustrations (Includes detailing from Section ~~R402.2.11~~ R402.2.10)  
[Note to reviewer – diagram unchanged]

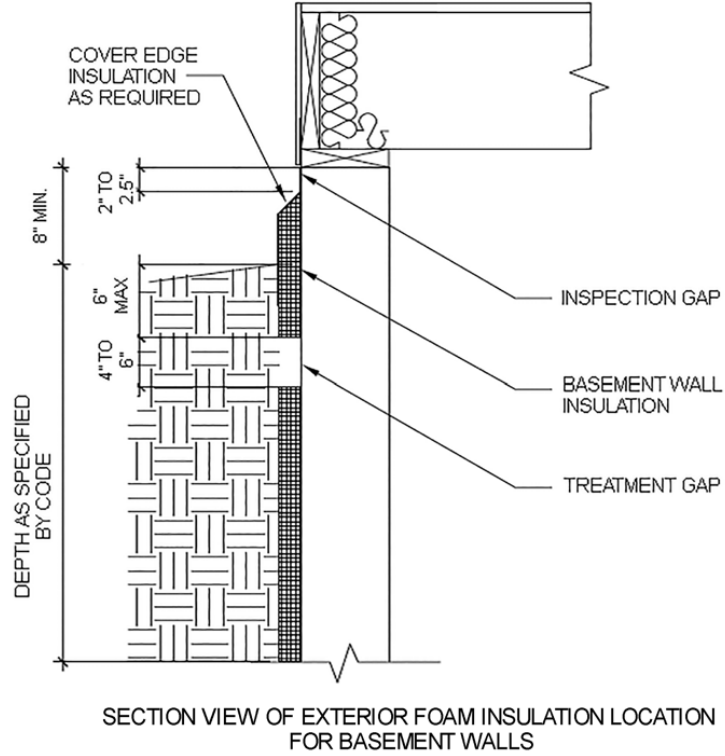

**R402.2.10 R402.2.9.1 Slab-on-grade floors.** Insulation illustrations  
 [Note to reviewer – no change to diagrams]

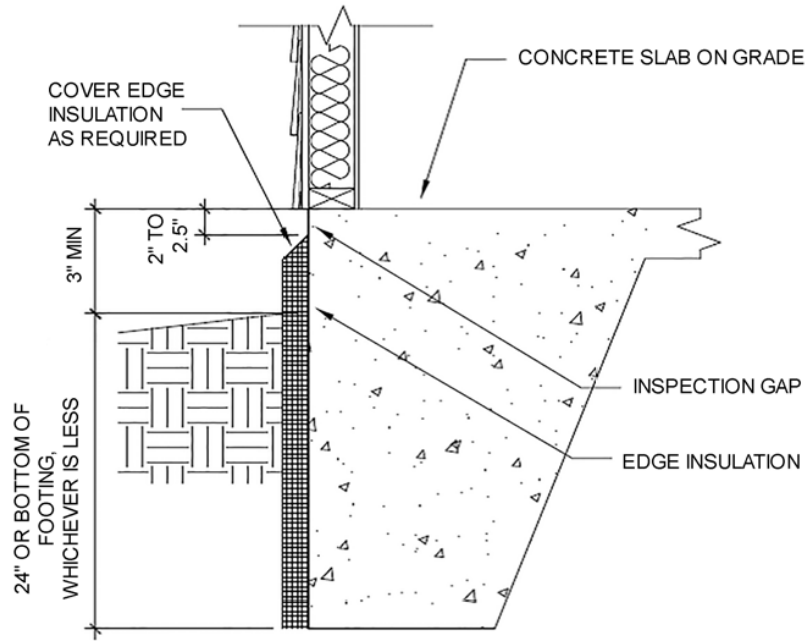

SECTION VIEW OF EDGE INSULATION FOR MONOLITHIC SLAB-ON-GRADE FLOORS

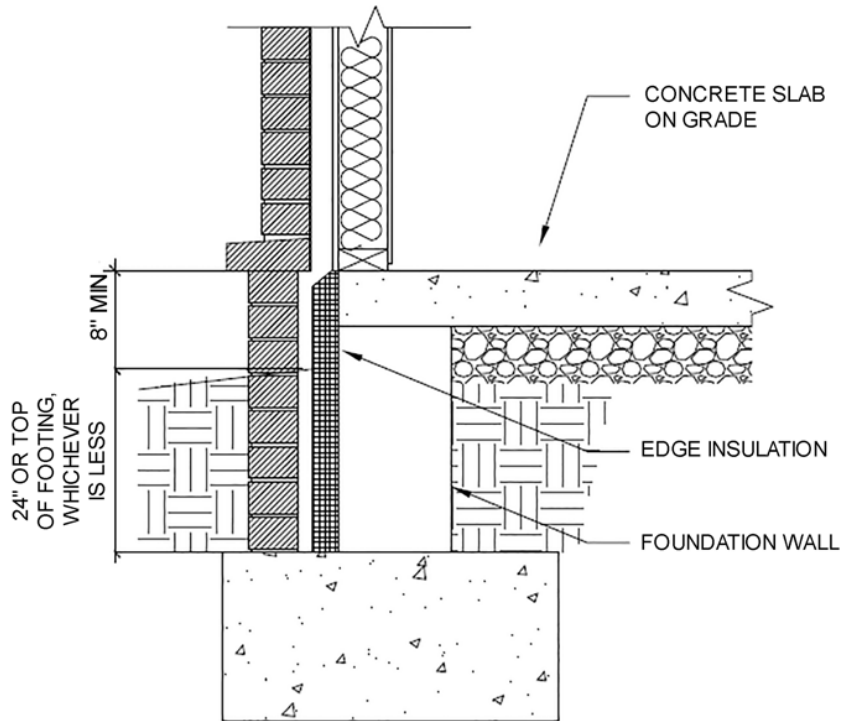

EXAMPLE FOR SLAB EDGE INSULATION LOCATION BEHIND BRICK, STONE, OR MASONRY FACING

**R402.2.10 R402.2.9.1 Slab-on-grade floors.** Insulation illustrations – Floating Slab with Stem Wall  
[Note to reviewer – no change to diagrams]

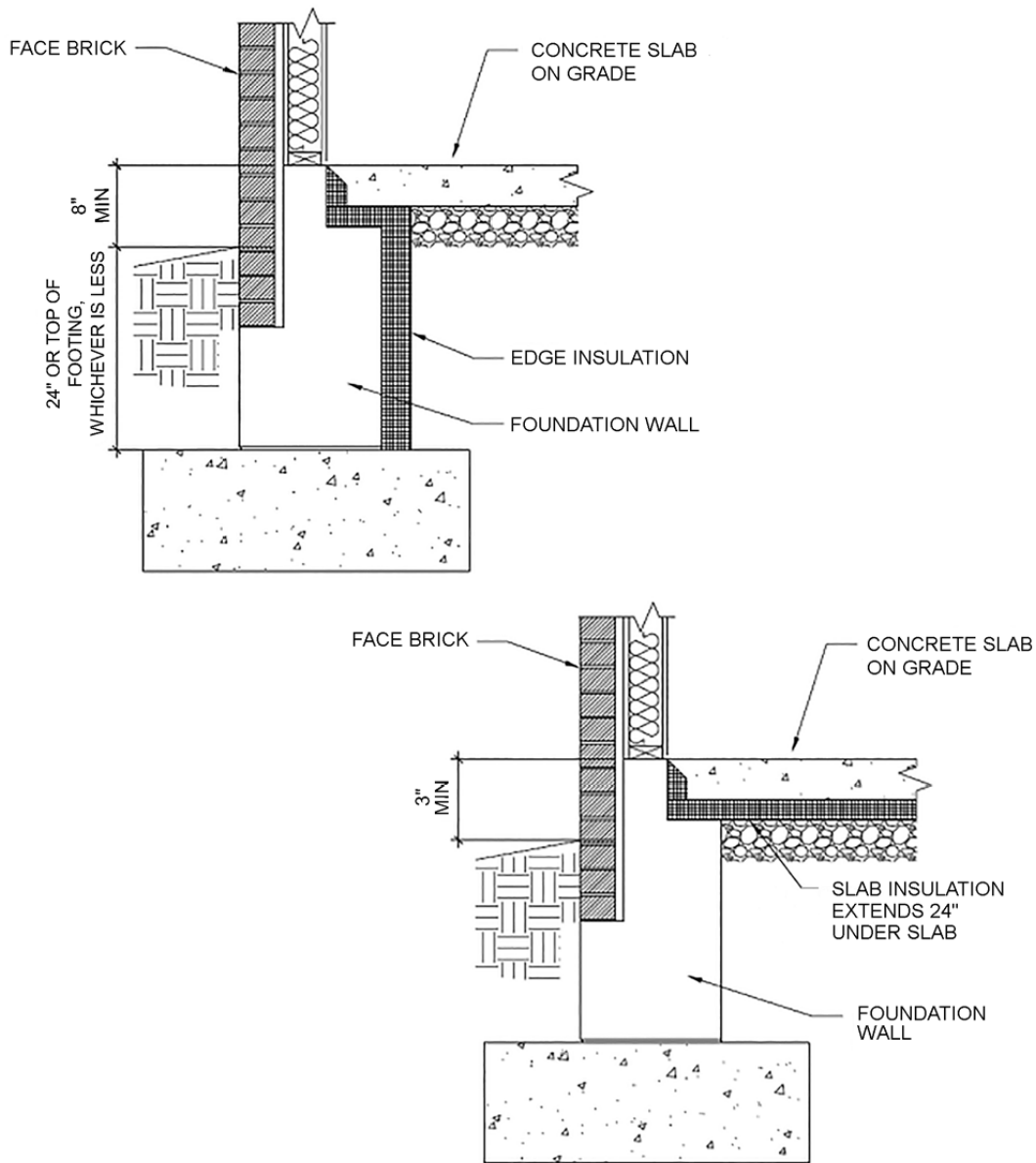

EXAMPLES FOR SLAB INSULATION LOCATION  
FOR FLOATING SLAB WITH STEM WALL  
(Options for brick facing are shown)



APPENDIX R3  
 SAMPLE WORKSHEETS FOR RESIDENTIAL AIR  
 AND DUCT LEAKAGE TESTING

APPENDIX R3A  
 Air sealing: Visual inspection option (Section R402.4.2.1)  
 Sample Worksheet  
 Not Used

~~R402.4.2 Air sealing. Building envelope air tightness shall be demonstrated by compliance with Section R402.4.2.1 or R402.4.2.2.~~

~~R402.4.2.1 Visual inspection option. Building envelope tightness shall be considered acceptable when items providing insulation enclosure in Section R402.2.14 and enclosure and air sealing in Section R402.2.15 and air sealing in Section R402.4.1 are addressed and when the items listed in Table R402.4.2, applicable to the method of construction, are certified by the builder, permit holder or registered design professional via the certificate in Appendix R1.1.~~

COMPONENT	CRITERIA
Ceiling/attic	Sealants or gaskets provide a continuous air barrier system joining the top plate of framed walls with either the ceiling drywall or the top edge of wall drywall to prevent air leakage. Top plate penetrations are sealed. For ceiling finishes that are not air barrier systems such as tongue and groove planks, air barrier systems (for example, taped house wrap), shall be used above the finish. Note: It is acceptable that sealants or gaskets applied as part of the application of the drywall will not be observable by the code official.
Walls	Sill plate is gasketed or sealed to subfloor or slab.
Windows and doors	Space between window and exterior door jambs and framing is sealed.
Floors (including above garage and cantilevered floors)	Air barrier system is installed at any exposed edge of insulation.
Penetrations	Utility penetrations through the building thermal envelope, including those for plumbing, electrical wiring, ductwork, security and fire alarm wiring, and control wiring, shall be sealed.
Garage separation	Air sealing is provided between the garage and conditioned spaces. An air barrier system shall be installed between the ceiling system above the garage and the ceiling system of interior spaces.
Ceiling penetrations	Ceiling electrical box penetrations and ceiling mechanical box penetrations shall be caulked, gasketed, or sealed at the penetration of the ceiling finish. See Appendix R1.2.4. <b>Exception:</b> Ceiling electrical boxes and ceiling mechanical boxes not penetrating the building thermal envelope.
Recessed lighting	Recessed light fixtures are air tight, IC rated, and sealed to drywall. <b>Exception:</b> Fixtures in conditioned space.

Property Address:

\_\_\_\_\_

**R402.4.2.1 Visual Inspection Option**

The inspection information including tester name, date, and contact shall be included on the certificate described in Section R401.3.

\_\_\_\_\_  
 Signature \_\_\_\_\_ Date \_\_\_\_\_

\_\_\_\_\_

**APPENDIX R3B**  
**Air sealing: Testing option (Section R402.4.2.2)-**  
**Sample Worksheet**

~~R402.4.2 Air sealing.~~ Building envelope air tightness shall be demonstrated by compliance with Section R402.4.2.1 or R402.4.2.2:

~~R402.4.2.2 Testing option.~~ Building envelope tightness shall be considered acceptable when items providing insulation enclosure in Section R402.2.14 and enclosure and air sealing in Section R402.2.15 and air sealing in Section R402.4.1 are addressed and when tested air leakage is less than or equal to one of the two following performance measurements:

~~2. 0.30 CFM50/Square Foot of Surface Area (SFSA) or~~

~~3. Five (5) air changes per hour (ACH50).~~

~~When tested with a blower door fan assembly, at a pressure of 33.5 psf (50 Pa). A single point depressurization, not temperature corrected, test is sufficient to comply with this provision, provided that the blower door fan assembly has been certified by the manufacturer to be capable of conducting tests in accordance with ASTM E779—03. Testing shall occur after rough in and after installation of penetrations of the building envelope, including penetrations for utilities, plumbing, electrical, ventilation and combustion appliances. Testing shall be reported by the permit holder, a North Carolina licensed general contractor, a North Carolina licensed HVAC contractor, a North Carolina licensed Home Inspector, a registered design professional, a certified BPI Envelope Professional or a certified HERS rater.~~

~~During testing:~~

- ~~• Exterior windows and doors, fireplace and stove doors shall be closed, but not sealed;~~
- ~~• Dampers shall be closed, but not sealed, including exhaust, backdraft, and flue dampers;~~
- ~~• Interior doors shall be open;~~
- ~~• Exterior openings for continuous ventilation systems, air intake ducted to the return side of the conditioning system, and energy or heat recovery ventilators shall be closed and sealed;~~
- ~~• Heating and cooling system(s) shall be turned off; and~~
- ~~• Supply and return registers shall not be sealed.~~

~~The air leakage information, building air leakage result, tester name, date, and contact information, shall be included on the certificate described in Section R401.3.~~

~~For Test Criteria 1 above, the report shall be produced in the following manner: Perform the blower door test and record the CFM50 \_\_\_\_\_. Calculate the total square feet of surface area for the building thermal envelope (all floors, ceilings, and walls including windows and doors, bounding conditioned space) and record the area \_\_\_\_\_. Divide CFM50 by the total square feet and record the result below. If the result is less than or equal to [0.30 CFM50/SFSA] the envelope tightness is acceptable; or~~

~~For Test Criteria 2 above, the report shall be produced in the following manner: Perform a blower door test and record the CFM50 \_\_\_\_\_. Multiply the CFM50 by 60 minutes to create CFHour50 and record \_\_\_\_\_. Then calculate the total conditioned volume of the home and record \_\_\_\_\_. Divide the CFH50 by the total volume and record the result below. If the result is less than or equal to [5 ACH50] the envelope tightness is acceptable.~~

Property Address: \_\_\_\_\_ Fan  
 attachment location \_\_\_\_\_ Company Name \_\_\_\_\_ Contact  
 Information: \_\_\_\_\_

Signature of Tester \_\_\_\_\_ Date \_\_\_\_\_

Permit Holder, NC Licensed General Contractor, NC Licensed HVAC Contractor, NC Licensed Home Inspector,  
 Registered Design Professional, Certified BPI Envelope Professional, or Certified HERS Rater  
 (circle one)

**APPENDIX R3B**  
**Air sealing: Testing (Section R402.4.1.2)**  
**Sample Worksheet – 4.0 ACH Requirement**

**R402.4.1.2 Testing.** The building or dwelling unit shall be tested for air leakage. Testing shall be conducted in accordance with ANSI/RESNET/ICC 380, ASTM E779 or ASTM E1827 and reported at a pressure of 0.2 inch w.g. (50 Pascals). If testing at a pressure of 75 Pa (0.30 in w.g.), Table Appendix R3B R402.4.1.2 shall be used for corresponding maximum allowed leakage. Where required by the code official, testing shall be conducted by an approved third party. A written report of the results of the test shall be signed by the party conducting the test and provided to the code official. Testing shall be performed at any time after creation of all penetrations of the building thermal envelope have been sealed.

- The maximum air leakage rate for any building or dwelling unit under any compliance path shall not exceed 4.0 air changes per hour (Test Criteria 1) or 0.23 cubic feet per minute (CFM) per square foot [0.0079 m<sup>3</sup>/(s × m<sup>2</sup>)] (Test Criteria 2) of dwelling unit enclosure area.
  - **Warning:** The 4.0 ACH threshold is a maximum for any compliance path, if following Section R401.2.1, 4.0 ACH is not allowed. See following section for requirements of R401.2.1
- When complying with Section R401.2.1, the building or dwelling unit shall have an air leakage rate not exceeding 3.0 air changes per hour in Climate Zones 3 through 5 when tested in accordance with Section R402.4.1.2. See APPENDIX R3B1 for Sample.

Table Appendix R3B R402.4.1.2 Adjustment for different test pressures

Pressure Differential (Pa)	Test pressure Adjustment Factor	Max Air Leakage / Building Thermal Envelope (CFM / ft <sup>2</sup> )					
		0.25	0.28	0.30	0.35	0.372	0.40
75 (0.30 in. w.g.)							
50 (0.20 in. w.g.)	0.752897957	0.19	0.21	0.23	0.26	0.28	0.30

Example: If maximum air leakage allowed is 0.28 cfm/SF of bldg thermal envelope at 50 Pa(0.2 in w.g.), the corresponding maximum leakage rate is 0.372 cfm/SF of bldg thermal envelope if using a test pressure of 75 Pa(0.3 in w.g.)

Testing shall be reported by the permit holder, a North Carolina licensed general contractor, a North Carolina licensed HVAC contractor, a North Carolina licensed Home Inspector, a registered design professional, a certified BPI Envelope Professional or a certified HERS rater.

During testing:

1. Exterior windows and doors, fireplace and stove doors shall be closed, but not sealed;
2. Dampers shall be closed, but not sealed, including exhaust, backdraft, and flue dampers;
3. Interior doors shall be open;
4. Exterior openings for continuous ventilation systems, air intake ducted to the return side of the conditioning system, and energy or heat recovery ventilators shall be closed and sealed;
5. Heating and cooling system(s) shall be turned off; and
6. Supply and return registers shall not be sealed.

The air leakage information, building air leakage result, tester name, date, and contact information, shall be included on the certificate described in Section R401.3.

**For Test Criteria 1** above, the report shall be produced in the following manner: Perform a blower door test and record the CFM50 \_\_\_\_\_. Multiply the CFM50 by 60 minutes to create CFHour50 and record \_\_\_\_\_. Then calculate the total conditioned volume of the home and record \_\_\_\_\_. Divide the CFH50 by the total volume and record the result below. If the result is less than or equal to [4.0 ACH50] the envelope tightness is acceptable.

**For Test Criteria 2** above, the report shall be produced in the following manner: Perform the blower door test and record the CFM50 \_\_\_\_\_. Calculate the total square feet of surface area for the building thermal envelope (all floors, ceilings, and walls including windows and doors, bounding conditioned space) and record the area \_\_\_\_\_. Divide CFM50 by the total square feet and record the result below. If the result is less than or equal to [0.23 CFM50/SFSA] the envelope tightness is

acceptable.

Property Address: \_\_\_\_\_

Fan attachment location \_\_\_\_\_ Company Name \_\_\_\_\_

Contact Information: \_\_\_\_\_

Signature of Tester \_\_\_\_\_ Date \_\_\_\_\_

Permit Holder, NC Licensed General Contractor, NC Licensed HVAC Contractor, NC Licensed Home Inspector,  
Registered Design Professional, Certified BPI Envelope Professional, or Certified HERS Rater  
(circle one)



**APPENDIX R3B1**  
**Air sealing: Testing (Section R402.4.1.2)**  
**Sample Worksheet – 3.0 ACH Requirement**

**R402.4.1.2 Testing.** The building or dwelling unit shall be tested for air leakage. Testing shall be conducted in accordance with ANSI/RESNET/ICC 380, ASTM E779 or ASTM E1827 and reported at a pressure of 0.2 inch w.g. (50 Pascals). Where required by the code official, testing shall be conducted by an approved third party. A written report of the results of the test shall be signed by the party conducting the test and provided to the code official. Testing shall be performed at any time after creation of all penetrations of the building thermal envelope have been sealed.

- Notice: When complying with Section R401.2.1, the building or dwelling unit shall have an air leakage rate not exceeding 3.0 air changes per hour in Climate Zones 3 through 5 when tested in accordance with Section R402.4.1.2.

Testing shall be reported by the permit holder, a North Carolina licensed general contractor, a North Carolina licensed HVAC contractor, a North Carolina licensed Home Inspector, a registered design professional, a certified BPI Envelope Professional or a certified HERS rater.

During testing:

1. Exterior windows and doors, fireplace and stove doors shall be closed, but not sealed;
2. Dampers shall be closed, but not sealed, including exhaust, backdraft, and flue dampers;
3. Interior doors shall be open;
4. Exterior openings for continuous ventilation systems, air intake ducted to the return side of the conditioning system, and energy or heat recovery ventilators shall be closed and sealed;
5. Heating and cooling system(s) shall be turned off; and
6. Supply and return registers shall not be sealed.

The air leakage information, building air leakage result, tester name, date, and contact information, shall be included on the certificate described in Section R401.3.

The report shall be produced in the following manner: Perform a blower door test and record the CFM50 . Multiply the CFM50 by 60 minutes to create CFHour50 and record . Then calculate the total conditioned volume of the home and record . Divide the CFH50 by the total volume and record the result below. If the result is less than or equal to [3.0 ACH50] the envelope tightness is acceptable.

Property Address: \_\_\_\_\_  
Fan attachment location \_\_\_\_\_ Company Name \_\_\_\_\_  
Contact Information: \_\_\_\_\_  
\_\_\_\_\_  
Signature of Tester \_\_\_\_\_ Date \_\_\_\_\_

Permit Holder, NC Licensed General Contractor, NC Licensed HVAC Contractor, NC Licensed Home Inspector,  
Registered Design Professional, Certified BPI Envelope Professional, or Certified HERS Rater  
**(circle one)**

**APPENDIX R3C**  
**Duct sealing. Duct air leakage test (Sections R403.3.2, Section R403.3.3)**  
**Sample Worksheet**

**R403.3.2 Sealing (Mandatory).** Ducts, air handlers, filter boxes, and building cavities used as ducts shall be sealed. Joints and seams shall comply with either the *International Mechanical Code* or *International Residential Code*, as applicable.

**Exception:** Air impermeable spray foam products shall be permitted to be applied without additional joint seals.

**R403.3.3 Duct leakage (Prescriptive) and duct testing (Mandatory).** Duct testing and duct leakage shall be verified by compliance with either Section R403.3.3.1 or R403.3.3.2. Duct testing shall be verified using one of the two following methods:

**R403.3.3.1 Total duct leakage.** Total duct leakage less than or equal to 5 cfm (12 L/min) per 100 square feet (9.29 m<sup>2</sup>) of conditioned floor area served by that system when tested at a pressure differential of 0.1 inches w.g. (25 Pa) across the entire system, including the manufacturer's air handler enclosure.

During testing:

1. Block, if present, ventilation air duct(s) connected to the conditioning system.
2. The duct air leakage testing equipment shall be attached to the largest return in the system or to the air handler.
3. The filter shall be removed and the air handler power shall be turned off.
4. Supply boots or registers and return boxes or grilles shall be taped, plugged, or otherwise sealed air tight.
5. The hose for measuring the 25 Pascals of pressure differential shall be inserted into the boot of the supply that is nominally closest to the air handler.
6. Specific instructions from the duct testing equipment manufacturer shall be followed to reach duct test pressure and measure duct air leakage.

**R403.3.3.2 Duct leakage to the outside.** Conduct the test using fan pressurization of distribution system and building at a fixed reference pressure for combined supply and return leaks. Duct leakage to the outside shall be less than or equal to 4 cfm (113.3 L/min) per 100 square feet (9.29 m<sup>2</sup>) of conditioned floor area served by that system when tested at a pressure differential of 0.1 inches w.g. (25 Pa) across the entire system, relative to the outside, including the manufacturer's air handler enclosure.

During testing:

1. Block, if present, the ventilation air duct(s) connected to the conditioning system.
2. The duct air leakage testing equipment shall be attached to the largest return in the system or to the air handler.
3. The filter shall be removed and the air handler power shall be turned off.
4. Supply boots or registers and return boxes or grilles shall be taped, plugged, or otherwise sealed air tight or as tight as possible.
5. The hose for measuring the 25 Pascals of pressure differential shall be inserted into the boot of the supply that is nominally closest to the air handler.
6. Open all interconnecting doors in the building, close dampers for fireplaces and other operable dampers.
7. Set up an envelope air moving/flow regulating/flow measurement assembly, such as a blower door, following the manufacturer's prescribed procedure.
8. Specific instructions from the duct testing equipment manufacturer shall be followed to reach duct test pressure and measure duct air leakage used in combination with a blower door. Typical steps are as follows:
  - a. Depressurize the ductwork system to 25 Pa using the measurement hose in Step 5 above.
  - b. Depressurize the house to 25 Pa using an envelope air moving/flow regulating/flow measurement assembly, such as a blower door.
  - c. Correct the duct pressure to measure 0 Pa of pressure differential between the house and the ductwork system.
  - d. Read the cfm of duct leakage using the procedures for the specific equipment being used. (Note that most automatically calculating pressure gauges cannot compute the CFM25 automatically with a duct to house difference in pressure of 0 Pa, so the gauge setting should be set to read cfm instead of CFM25).

Testing shall be performed and reported by the permit holder, a North Carolina licensed general contractor, a North Carolina licensed HVAC contractor, a North Carolina licensed home inspector, a *registered design professional*, a certified *BPI Envelope Professional* or a certified *HERS rater*. A single point depressurization, not temperature corrected, test is sufficient to comply with this provision, provided that the duct testing fan assembly(s) has been certified by the manufacturer

to be capable of conducting tests in accordance with ASTM E1554—07.

The duct leakage information, including duct leakage test selected and result, tester name, date, and contact information, shall be included on the certificate described in Section 401.3.

For the Test Criteria, the report shall be produced in the following manner: perform the HVAC system air leakage test and record the CFM25. Calculate the total square feet of Conditioned Floor Area (CFA) served by that system. Multiply CFM25 by 100, divide the result by the CFA and record the result. If the result is less than or equal to 5 CFM25/100SF for the Total duct leakage test or less than or equal to 4 CFM25/100SF for the “Duct leakage to the outside” test, then the HVAC system air tightness is acceptable.

Complete one duct leakage report for each HVAC system serving the home:

Property Address: \_\_\_\_\_

Test Performed: Total duct leakage or Duct leakage to the outside **(circle one)**

HVAC System Number: \_\_\_\_\_ Describe area of home served: \_\_\_\_\_

CFM25 Total \_\_\_\_\_. Conditioned Floor Area (CFA) served by system: \_\_\_\_\_ s.f.

CFM25 x 100 divided by CFA = \_\_\_\_ CFM25/100SF (e.g. 100 CFM25 x 100/ 2,000 CFA = 5 CFM25/100SF)

Fan attachment location \_\_\_\_\_

Company Name \_\_\_\_\_

Contact Information: \_\_\_\_\_

\_\_\_\_\_

Signature of Tester \_\_\_\_\_ Date \_\_\_\_\_

Permit Holder, NC Licensed General Contractor, NC Licensed HVAC Contractor, NC Licensed Home Inspector,  
*Registered Design Professional, Certified BPI Envelope Professional, or Certified HERS Rater*  
**(circle one)**

**APPENDIX R3C**  
**Duct sealing. Duct air leakage test (Sections R403.3.2, Section R403.3.3)**  
**Sample Worksheet**

**R403.3.4 Sealing (Mandatory).** Ducts, air handlers, filter boxes, and building cavities used as ducts shall be sealed. Joints and seams shall comply with either the *International Mechanical Code* or *International Residential Code*, as applicable.

**Exception:** Air-impermeable spray foam products shall be permitted to be applied without additional joint seals.

**R403.3.5 Duct testing.** Ducts shall be pressure tested in accordance with ANSI/RESNET/ICC 380 or ASTM E1554 to determine air leakage by one of the following methods:

1. Rough-in test: Total leakage shall be measured with a pressure differential of 0.1 inch w.g. (25 Pa) across the system, including the manufacturer's air handler enclosure if installed at the time of the test. Registers shall be taped or otherwise sealed during the test.
2. Postconstruction test: Total leakage shall be measured with a pressure differential of 0.1 inch w.g. (25 Pa) across the entire system, including the manufacturer's air handler enclosure. Registers shall be taped or otherwise sealed during the test.

**Exception:** A duct air-leakage test shall not be required for ducts serving heating, cooling or ventilation systems that are not integrated with ducts serving heating or cooling systems.

**R403.3.6 Duct leakage.** The total leakage of the ducts, where measured in accordance with Section R403.3.5, shall be as follows:

1. Rough-in test: The total leakage shall be less than or equal to 4.0 cubic feet per minute (113.3 L/min) per 100 square feet (9.29 m<sup>2</sup>) of conditioned floor area where the air handler is installed at the time of the test. Where the air handler is not installed at the time of the test, the total leakage shall be less than or equal to 3.0 cubic feet per minute (85 L/min) per 100 square feet (9.29 m<sup>2</sup>) of conditioned floor area.
2. Postconstruction test: Total leakage shall be less than or equal to 4.0 cubic feet per minute (113.3 L/min) per 100 square feet (9.29 m<sup>2</sup>) of conditioned floor area.
3. Test for ducts within thermal envelope: Where all ducts and air handlers are located entirely within the building thermal envelope, total leakage shall be less than or equal to 8.0 cubic feet per minute (226.6 L/min) per 100 square feet (9.29 m<sup>2</sup>) of conditioned floor area.

During testing:

1. Block, if present, ventilation air duct(s) connected to the conditioning system.
2. The duct air leakage testing equipment shall be attached to the largest return in the system or to the air handler.
3. The filter shall be removed and the air handler power shall be turned off.
4. Supply boots or registers and return boxes or grilles shall be taped, plugged, or otherwise sealed air tight.
5. The hose for measuring the 25 Pascals of pressure differential shall be inserted into the boot of the supply that is nominally closest to the air handler.
6. Specific instructions from the duct testing equipment manufacturer shall be followed to reach duct test pressure and measure duct air leakage.

Testing shall be performed and reported by the permit holder, a North Carolina licensed general contractor, a North Carolina licensed HVAC contractor, a North Carolina licensed home inspector, a registered design professional, a certified BPI Envelope Professional or a certified HERS rater. A single point depressurization, not temperature corrected, test is sufficient to comply with this provision, provided that the duct testing fan assembly(s) has been certified by the manufacturer to be capable of conducting tests in accordance with ASTM E1554—07.

The duct leakage information, including duct leakage test selected and result, tester name, date, and contact information, shall be included on the certificate described in Section 401.3.

For the Test Criteria, the report shall be produced in the following manner: perform the HVAC system air leakage test and record the CFM25. Calculate the total square feet of Conditioned Floor Area (CFA) served by that system.

- (1) Rough-in test: The total leakage shall be less than or equal to 4.0 cubic feet per minute (113.3 L/min) per 100 square feet (9.29 m<sup>2</sup>) of conditioned floor area where the air handler is installed at the time of the test. Where the air handler is not installed at the time of the test, the total leakage shall be less than or equal to 3.0 cubic feet per minute

(85 L/min) per 100 square feet (9.29 m<sup>2</sup>) of conditioned floor area. Multiply CFM25 by 100, divide the result by the CFA and record the result. If the result is less than or equal to 3.0 CFM25/100SF (without airhandler, 4.0 with air handler) for the Total duct leakage test, then the HVAC system air tightness is acceptable.

- (2) Postconstruction test: Multiply CFM25 by 100, divide the result by the CFA and record the result. If the result is less than or equal to 5 CFM25/100SF for the Total duct leakage test, then the HVAC system air tightness is acceptable.
- (3) Test for ducts within thermal envelope: Where all ducts and air handlers are located entirely within the building thermal envelope, total leakage shall be less than or equal to 8.0 cubic feet per minute (226.6 L/min) per 100 square feet (9.29 m<sup>2</sup>) of conditioned floor area. Multiply CFM25 by 100, divide the result by the CFA and record the result. If the result is less than or equal to 8.0 CFM25/100SF for the Total duct leakage test, then the HVAC system air tightness is acceptable.

Complete one duct leakage report for each HVAC system serving the home:

Property Address: \_\_\_\_\_

Test Performed: (1) Rough-in test, (2) Postconstruction test, (3) Ducts within thermal envelope test (circle one)

HVAC System Number: \_\_\_\_\_ Describe area of home served: \_\_\_\_\_

CFM25 Total \_\_\_\_\_ Conditioned Floor Area (CFA) served by system: \_\_\_\_\_ s.f.

CFM25 x 100 divided by CFA = \_\_\_\_\_ CFM25/100SF (e.g. 100 CFM25  $\square$  100/ 2,000 CFA = 5 CFM25/100SF)

Fan attachment location \_\_\_\_\_

Company Name \_\_\_\_\_

Contact Information: \_\_\_\_\_

\_\_\_\_\_  
Signature of Tester \_\_\_\_\_ Date \_\_\_\_\_

Permit Holder, NC Licensed General Contractor, NC Licensed HVAC Contractor, NC Licensed Home Inspector, Registered Design Professional, Certified BPI Envelope Professional, or Certified HERS Rater (circle one)

## APPENDIX R4

# ADDITIONAL VOLUNTARY CRITERIA FOR INCREASING ENERGY EFFICIENCY (High-Efficiency Residential Option)

Table R4C

Not used

1. **Introduction.** The increased energy efficiency measures identified in this appendix are strictly voluntary at the option of the permit holder and have been evaluated to be the most cost effective measures for achieving an additional 10- to 15-percent energy efficiency beyond the code minimums.

2. **Requirements:** Follow all sections of residential building provisions of the 2018 *North Carolina Energy Conservation Code*, except the following:

a. Instead of using Table R402.1.2 in Section R402.1.2, use Table 4A shown below

**TABLE 4A  
INSULATION AND FENESTRATION REQUIREMENTS BY COMPONENT<sup>a</sup>**

CLIMATE ZONE	FENESTRATION U-FACTOR <sup>b, j</sup>	SKYLIGHT U-FACTOR	GLAZED FENESTRATION SHGC <sup>c, k</sup>	CEILING R-VALUE <sup>m</sup>	WOOD FRAME WALL R-VALUE	MASS WALL R-VALUE <sup>i</sup>	FLOOR R-VALUE	BASEMENT <sup>c, o</sup> WALL R-VALUE	SLAB <sup>d</sup> R-VALUE	CRAWL SPACE <sup>c</sup> WALL R-VALUE
3	0.32	0.55	0.25	38 or 30 ci <sup>l</sup>	19, 13+5, or 15+3 <sup>h</sup>	5/13 or 5/10ci	19	5/13 <sup>f</sup>	5	5/13
4	0.32	0.55	0.25	38 or 30 ci <sup>l</sup>	19, 13+5, or 15+3 <sup>h</sup>	5/13 or 5/10ci	19	10/15	10	10/15
5	0.22	0.55	(NR)	38 or 30 ci <sup>l</sup>	19, 13+5, or 15+3 <sup>h</sup>	13/17 or 13/12.5 ci	30 <sup>g</sup>	10/15	10	10/19

<sup>a</sup> For SI: 1 foot = 304.8 mm.

a. *R* values are minimums. *U* factors and SHGC are maximums. When insulation is installed in a cavity which is less than the label or design thickness of the insulation, the installed *R* value of the insulation shall not be less than the *R* value specified in the table.

b. The fenestration *U* factor column excludes skylights. The SHGC column applies to all glazed fenestration.

c. "10/15" means R-10 continuous insulated sheathing on the interior or exterior of the home or R-15 cavity insulation at the interior of the basement wall or crawl space wall.

d. For monolithic slabs, insulation shall be applied from the inspection gap downward to the bottom of the footing or a maximum of 24 inches below grade, whichever is less. For floating slabs, insulation shall extend to the bottom of the foundation wall or 24 inches, whichever is less (see Appendix R2). R-5 shall be added to the required slab edge *R* values for heated slabs.

e. Deleted.

f. Basement wall insulation is not required in warm humid locations as defined by Figure R301.1 and Table R301.1.

g. Or insulation sufficient to fill the framing cavity, R-19 minimum.

h. The first value is cavity insulation, the second value is continuous insulation, so "13+5" means R-13 cavity insulation plus R-5 continuous insulation. If structural sheathing covers 25 percent or less of the exterior, insulating sheathing is not required where structural sheathing is used. If structural sheathing covers more than 25 percent of exterior, structural sheathing shall be supplemented with insulated sheathing of at least R-2.

i. The second *R* value applies when more than half the insulation is on the interior of the mass wall.

j. In addition to the exemption in Section R402.3.3, a maximum of two glazed fenestration product assemblies having a *U* factor no greater than 0.55 shall be permitted to be substituted for minimum code compliant fenestration product assemblies without penalty.

k. In addition to the exemption in Section R402.3.3, a maximum of two glazed fenestration product assemblies having a SHGC no greater than 0.70 shall be permitted to be substituted for minimum code compliant fenestration product assemblies without penalty.

l. R-30 shall be deemed to satisfy the ceiling insulation requirement wherever the full height of uncompressed R-30 insulation extends over the wall top plate at the eaves. Otherwise R-38 insulation is required where adequate clearance exists or insulation must extend to either the insulation baffle or within 1 inch of the attic roof deck.

m. Table value required except for roof edge where the space is limited by the pitch of the roof, there the insulation must fill the space up to the air baffle.

n. R-19 fiberglass batts compressed and installed in a nominal 2 × 6 framing cavity is deemed to comply. Fiberglass batts rated R-19 or higher compressed and installed in a 2 × 4 wall is not deemed to comply.

o. Basement wall meeting the minimum mass wall specific heat content requirement may use the mass wall *R* value as the minimum requirement.

b. Instead of using Table R402.1.4 in Section R402.1.4, use Table 4B to find the maximum *U* factors for building components.

TABLE 4B  
EQUIVALENT *U*-FACTORS<sup>a</sup>

CLIMATE ZONE	FENESTRATION <i>U</i> -FACTOR <sup>d</sup>	SKYLIGHT <i>U</i> -FACTOR	CEILING <i>U</i> -FACTOR	FRAME WALL <i>U</i> -FACTOR	MASS WALL <i>U</i> -FACTOR <sup>b</sup>	FLOOR <i>U</i> -FACTOR	BASEMENT WALL <i>U</i> -FACTOR <sup>c</sup>	CRAWL SPACE WALL <i>U</i> -FACTOR
3	0.32	0.55	0.030	0.061	0.141	0.047	0.091	0.136
4	0.32	0.55	0.030	0.061	0.141	0.047	0.059	0.065
5	0.32	0.55	0.030	0.061	0.082	0.033	0.059	0.065

a. Nonfenestration *U* factors shall be obtained from measurement, calculation or an approved source.

b. When more than half the insulation is on the interior, the mass wall *U* factors shall be a maximum of 0.07 in Climate Zone 3, 0.07 in Climate Zone 4, and 0.054 in Climate Zone 5.

c. Basement wall *U* factor of 0.360 in warm humid locations as defined by Figure R301.1 and Table R301.1.

d. A maximum of two glazed fenestration product assemblies having a *U* factor no greater than 0.55 and a SHGC no greater than 0.70 shall be permitted to be substituted for minimum code compliant fenestration product assemblies without penalty.

e. For compliance with Section R402.4 Air leakage control (Mandatory), Sections R402.4.1 (Building thermal envelope) and R402.4.2.2 (Testing option) must be followed, with the maximum leakage rate shown below. Section R402.4.2.1 (Visual inspection option) cannot be used to show compliance:

- i. 0.24 CFM50/Square Foot of Surface Area (SFSFA); or
- ii. Four (4) air changes per hour (ACH50)

d. Instead of using the duct leakage value for maximum leakage shown in Section R403.3.3 use the following:

1. **R403.3.3.1 Total duct leakage.** Total duct leakage shall be less than or equal to 4 cfm (113 L/min) per 100 square feet (9.29 m<sup>2</sup>) of conditioned floor area served by that system when tested at a pressure differential of 0.1 inches w.g. (25 Pa) across the entire system, including the manufacturer's air handler enclosure.

2. **R403.3.3.2 Duct leakage to the outside.** Conduct the test using fan pressurization of distribution system and building at a fixed reference pressure for combined supply and return leak. Duct leakage to the outside shall be less than or equal to 3 cfm (85 L/min) per 100 square feet (9.29 m<sup>2</sup>) of conditioned floor area served by that system when tested at a pressure differential of 0.1 inches w.g. (25 Pa) across the entire system, relative to the outside, including the manufacturer's air handler enclosure.

e. For compliance with Section R404.1 (Lighting equipment), the home must comply with the following:

Not less than 90 percent of the lamps in permanently installed lighting fixtures shall be high efficacy lamps or not less than 90 percent of the permanently installed lighting fixtures shall contain only high efficacy lamp

**Table R4C**  
**Sample Confirmation Form for**  
**ADDITIONAL VOLUNTARY CRITERIA FOR INCREASING ENERGY EFFICIENCY**  
**(High-Efficiency Residential Option)**

<b>NORTH CAROLINA ENERGY CONSERVATION CODE:</b> <b>HIGH-EFFICIENCY RESIDENTIAL OPTION, INSULATION AND FENESTRATION VALUES</b> <small>(Notes correlate to Table R4A)</small>				<b>PROPOSED PROJECT VALUES</b>
Climate Zone	3	4	5	
Fenestration <i>U</i> -Factor <sup>b,j</sup>	0.32	0.32	0.32	
Skylight <i>U</i> -Factor <sup>b</sup>	0.55	0.55	0.55	
Glazed Fenestration SHGC <sup>b,k</sup>	0.25	0.25	(NR)	
Ceiling <i>R</i> -value <sup>m</sup>	38 or 30 ci <sup>l</sup>	38 or 30 ci <sup>l</sup>	38 or 30 ci <sup>l</sup>	
Wood Frame Wall <i>R</i> -value <sup>h</sup>	19, 13+5, or 15+3	19, 13+5, or 15+3	19, 13+5, or 15+3	
Mass Wall <i>R</i> -value <sup>i</sup>	5/13 or 5/10ci	5/13 or 5/10ci	13/17 or 13/12.5ci	
Floor <i>R</i> -value	19	19	30 <sup>g</sup>	
Basement Wall <i>R</i> -value <sup>e,n</sup>	5 /13 <sup>f</sup>	10/15	10/15	
Slab <i>R</i> -value and Depth <sup>d</sup>	5	10	10	
Crawl Space Wall <i>R</i> -value <sup>e</sup>	5/13	10/15	10/19	
* Note: <i>ci</i> = continuous insulation				
<b>High Efficacy Lighting</b>				
% of lighting that is high efficacy according to R404.1 (90% required)				
<b>Building Air Leakage</b>				
Building Air Leakage Test according to R402.4.2.2 (check box). Show test value:				
ACH50 [Target: 4.0], or				
CFM50/SFSA [Target: 0.24]				
Name of Tester / Company:				
Date: Phone:				
<b>Duct Insulation and Sealing</b>				
Insulation Value R-				
Duct Leakage Test Result (Sect. R405.3.3)				
(CFM25 Total/100SF) [Target: 4 Total/ 3 To exterior] <input type="checkbox"/> Total duct leakage or <input type="checkbox"/> Duct leakage to the exterior				
Name of Tester or Company:				
Date: Phone:				



Sample Confirmation Form for ADDITIONAL VOLUNTARY CRITERIA FOR INCREASING ENERGY EFFICIENCY (High-Efficiency Residential Option)

Not Used

-

---

**R4D:**  
**SAMPLE WORKSHEETS FOR RESIDENTIAL AIR AND DUCT LEAKAGE TESTING**  
**R4D.1**

**Air sealing: Testing (Section R402.4.2.2)**

**Sample Worksheet for Alternative Residential Energy Code for Higher Efficiency**

**Air sealing.** Building envelope air tightness shall be demonstrated by Section R402.4.2.2:

**Air sealing: Testing (Section R402.4.2.2)**

**Sample Worksheet for Alternative Residential Energy Code for Higher Efficiency**

Not used in 2024 Proposed Code

**R4D:**  
**SAMPLE WORKSHEETS FOR RESIDENTIAL AIR AND DUCT LEAKAGE TESTING**  
**R4D.1**

**Air sealing: Testing (Section R402.4.2.2)**

**Sample Worksheet for Alternative Residential Energy Code for Higher Efficiency**

**Air sealing.** Building envelope air tightness shall be demonstrated by Section R402.4.2.2:

**Air sealing: Testing (Section R402.4.2.2)**

**Sample Worksheet for Alternative Residential Energy Code for Higher Efficiency**

**N1102.4.2.2 Testing.** Building envelope tightness shall be considered acceptable when items providing insulation enclosure in R402.2.14 and enclosure and air sealing in Section R402.2.15 and air sealing in Section R402.4.1 are addressed and when tested air leakage is less than or equal to one of the two following performance measurements:

~~2. 0.24 CFM50 (6.8 L/min)/Square Foot of Surface Area (SFSA) or~~

~~3. Four (4) air changes per hour (ACH50)~~

~~When tested with a blower door fan assembly, at a pressure of 0.2 inches water gauge (50 Pa), a single point depressurization, not temperature corrected, test is sufficient to comply with this provision, provided that the blower door fan assembly has been certified by the manufacturer to be capable of conducting tests in accordance with ASTM E779 – 03. Testing shall occur after rough in and after installation of penetrations of the building envelope, including penetrations for utilities, plumbing, electrical, ventilation and combustion appliances. Testing shall be reported by the permit holder, a North Carolina licensed general contractor, a North Carolina licensed HVAC contractor, a North Carolina licensed Home Inspector, a *registered design professional*, a certified *BPI Envelope Professional* or a certified *HERS rater*.~~

~~During testing:~~

- ~~• Exterior windows and doors, fireplace and stove doors shall be closed, but not sealed;~~
- ~~• Dampers shall be closed, but not sealed, including exhaust, backdraft, and flue dampers;~~
- ~~• Interior doors shall be open;~~
- ~~• Exterior openings for continuous ventilation systems, air intake ducted to the return side of the conditioning system, and energy or heat recovery ventilators shall be closed and sealed;~~
- ~~• Heating and cooling system(s) shall be turned off; and~~
- ~~• Supply and return registers shall not be sealed.~~

~~The air leakage information, including building air leakage result, tester name, date, and contact information, shall be included on the certificate described in Section R401.3.~~

~~For Test Criteria 1 above, the report shall be produced in the following manner: Perform the blower door test and record the CFM50 \_\_\_\_\_. Calculate the total square feet of surface area for the building thermal envelope, all floors, ceilings, and walls (this includes windows and doors) and record the area \_\_\_\_\_. Divide CFM50 by the total square feet and record the result below. If the result is less than or equal to [0.24 CFM50/SFSA] the envelope tightness is acceptable; or~~

~~For Test Criteria 2 above, the report shall be produced in the following manner: Perform a blower door test and record the CFM50 = \_\_\_\_\_. Multiply the CFM50 by 60 minutes to create CF/Hour50 and record = \_\_\_\_\_. Then calculate the total conditioned volume of the home and record = \_\_\_\_\_ cubic feet. Divide the CF/Hour50 by the total volume and record the result = \_\_\_\_\_ ACH50. If the result is less than or equal to [4 ACH50] the envelope tightness is acceptable.~~

Property Address: \_\_\_\_\_ Fan  
attachment location \_\_\_\_\_ Company Name \_\_\_\_\_ Contact  
Information: \_\_\_\_\_

Signature of Tester \_\_\_\_\_ Date \_\_\_\_\_

Permit Holder, NC Licensed General Contractor, NC Licensed HVAC Contractor, NC Licensed Home Inspector,  
\_\_\_\_\_  
*Registered Design Professional, Certified BPI Envelope Professional, or Certified HERS Rater*  
**(circle one)**

## R4D.2

### Duct sealing. Duct air leakage test (Section R403.3.3)

#### Sample Worksheet for Alternative Residential Energy Code for Higher Efficiency

**R403.3.3 Duct leakage (Prescriptive) and Duct Testing (Mandatory).** Duct testing and duct leakage shall be verified by compliance

with either Section R403.3.3.1 or R403.3.3.2. Duct testing shall be performed and reported by the permit holder, a North Carolina licensed general contractor, a North Carolina licensed HVAC contractor, a North Carolina licensed Home Inspector, a registered design professional, a certified BPI Envelope Professional or a certified HERS rater. A single point depressurization;

not temperature corrected, test is sufficient to comply with this provision, provided that the duct testing fan assembly(s) has been

certified by the manufacturer to be capable of conducting tests in accordance with ASTM E1554—07.

The duct leakage information, including duct leakage test selected and result, tester name, date, and contact information, shall be

included on the certificate described in Section R401.3.

For the Test Criteria, the report shall be produced in the following manner: perform the HVAC system air leakage test and record the CFM25. Calculate the total square feet of Conditioned Floor Area (CFA) served by that system. Multiply CFM25 by 100, divide the result by the CFA and record the result. If the result is less than or equal to 4 CFM25/100SF for the “Total duct leakage test” or less than or equal to 3 CFM25/100SF for the “Duct leakage to the outside” test, then the HVAC system air tightness

is acceptable.

#### Exceptions to testing requirements:

1. Duct systems or portions thereof inside the building thermal envelope shall not be required to be leak tested.
2. Installation of a partial system as part of replacement, renovation or addition does not require a duct leakage test.

**R403.3.3.1 Total duct leakage.** Total duct leakage less than or equal to 4 cfm (113 L/min) per 100 square feet (9.29 m<sup>2</sup>) of conditioned floor area served by that system when tested at a pressure differential of 0.1 inches w.g. (25 Pa) across the entire system, including the manufacturer’s air handler enclosure. During testing:

1. Block, if present, ventilation air duct(s) connected to the conditioning system.
2. The duct air leakage testing equipment shall be attached to the largest return in the system or to the air handler.
3. The filter shall be removed and the air handler power shall be turned off.
4. Supply boots or registers and return boxes or grilles shall be taped, plugged, or otherwise sealed air tight.
5. The hose for measuring the 25 Pascals of pressure differential shall be inserted into the boot of the supply that is nominally closest to the air handler.
6. Specific instructions from the duct testing equipment manufacturer shall be followed to reach duct test pressure and measure duct air leakage.

**R403.3.3.2 Duct leakage to the outside.** Conduct the test using fan pressurization of distribution system and building at a fixed reference pressure for combined supply and return leak. Duct leakage to the outside shall be less than or equal to 3 cfm (85 L/min) per 100 square feet (9.29 m<sup>2</sup>) of conditioned floor area served by that system when tested at a pressure differential of 0.1 inches w.g. (25 Pa) across the entire system, relative to the outside, including the manufacturer’s air handler enclosure. During testing:

1. Block, if present, the ventilation air duct(s) connected to the conditioning system.
2. The duct air leakage testing equipment shall be attached to the largest return in the system or to the air handler.
3. The filter shall be removed and the air handler power shall be turned off.

4. Supply boots or registers and return boxes or grilles shall be taped, plugged, or otherwise sealed air tight or as tight as possible.
5. The hose for measuring the 25 Pascals of pressure differential shall be inserted into the boot of the supply that is nominally closest to the air handler.
6. Open all interconnecting doors in the building, close dampers for fireplaces and other operable dampers.
7. Set up an envelope air moving/ flow regulating/ flow measurement assembly, such as a blower door, following the manufacturer's prescribed procedure.
8. Specific instructions from the duct testing equipment manufacturer shall be followed to reach duct test pressure and measure duct air leakage used in combination with a blower door. Typical steps are as follows:
  - a. Depressurize the ductwork system to 25 Pa using the measurement hose in Step 5 above.
  - b. Depressurize the house to 25 Pa using an envelope air moving/flow regulating/flow measurement assembly, such as a blower door.
  - c. Correct the duct pressure to measure 0 Pa of pressure differential between the house and the ductwork system.
  - d. Read the cfm of duct leakage using the procedures for the specific equipment being used. (Note that most automatically calculating pressure gauges cannot compute the CFM25 automatically with a duct to house difference in pressure of 0 Pa, so the gauge setting should be set to read CFM instead of CFM25).

**Complete one duct leakage report for each HVAC system serving the home:**

Property Address: \_\_\_\_\_

HVAC System Number: \_\_\_\_\_ Describe area of home served: \_\_\_\_\_

CFM25 Total \_\_\_\_\_. Conditioned Floor Area (CFA) served by system: \_\_\_\_\_ s.f.

CFM25  $\square$  100 divided by CFA = \_\_\_\_ CFM25/100SF (e.g. 50 CFM25  $\square$  100/ 2,000 CFA = 5 CFM25/100SF)

Fan attachment location \_\_\_\_\_

Company Name \_\_\_\_\_

Contact Information: \_\_\_\_\_

\_\_\_\_\_

\_\_\_\_\_

Signature of Tester Date \_\_\_\_\_

Permit Holder, NC Licensed General Contractor, NC Licensed HVAC Contractor, NC Licensed Home Inspector, Registered Design Professional, Certified BPI Envelope Professional, or Certified HERS Rater

**(circle one)**



APPENDIX RA  
BOARD OF APPEALS—RESIDENTIAL  
Deleted – No change from 2018

APPENDIX RB  
**SOLAR-READY PROVISIONS—DETACHED ONE- AND TWO-FAMILY DWELLINGS AND TOWNHOUSES**

*The provisions contained in this appendix are not mandatory.*

**SECTION RB101**  
**SCOPE**

**RB101.1 General.** These provisions shall be applicable for new construction where solar-ready provisions are required.

**SECTION RB102**  
**GENERAL DEFINITION**

**SOLAR-READY ZONE.** A section or sections of the roof or building overhang designated and reserved for the future installation of a solar photovoltaic or solar thermal system.

**SECTION RB103**  
**SOLAR-READY ZONE**

**RB103.1 General.** New detached one- and two-family dwellings, and townhouses with not less than 600 square feet (55.74 m<sup>2</sup>) of roof area oriented between 110 degrees and 270 degrees of true north shall comply with Sections RB103.2 through RB103.8.

**Exceptions:**

1. New residential buildings with a permanently installed on-site renewable energy system.
2. A building where all areas of the roof that would otherwise meet the requirements of Section RB103 are in full or partial shade for more than 70 percent of daylight hours annually.

**RB103.2 Construction document requirements for solar-ready zone.** Construction documents shall indicate the solar-ready zone.

**RB103.3 Solar-ready zone area.** The total solar-ready zone area shall be not less than 300 square feet (27.87 m<sup>2</sup>) exclusive of mandatory access or setback areas as required by the *International Fire Code*. New townhouses three stories or less in height above grade plane and with a total floor area less than or equal to 2,000 square feet (185.8 m<sup>2</sup>) per dwelling shall have a solar-ready zone area of not less than 150 square feet (13.94 m<sup>2</sup>). The solar-ready zone shall be composed of areas not less than 5 feet (1524 mm) in width and not less than 80 square feet (7.44 m<sup>2</sup>) exclusive of access or setback areas as required by the *International Fire Code*.

**RB103.4 Obstructions.** Solar-ready zones shall be free from obstructions, including but not limited to vents, chimneys, and roof-mounted equipment.

**RB103.5 Shading.** The solar-ready zone shall be set back from any existing or new permanently affixed object on the building or site that is located south, east or west of the solar zone a distance not less than two times the object's height above the nearest point on the roof surface. Such objects include, but are not limited to, taller portions of the building itself, parapets, chimneys, antennas, signage, rooftop equipment, trees and roof plantings.

**RB103.6 Capped roof penetration sleeve.** A capped roof penetration sleeve shall be provided adjacent to a solar-ready zone located on a roof slope of not greater than 1 unit vertical in 12 units horizontal (8-percent slope). The capped roof penetration sleeve shall be sized to accommodate the future photovoltaic system conduit, but shall have an inside diameter of not less than 1<sup>1</sup>/<sub>4</sub> inches (32 mm).

**RB103.7 Roof load documentation.** The structural design loads for roof dead load and roof live load shall be clearly indicated on the construction documents.

**RB103.8 Interconnection pathway.** Construction documents shall indicate pathways for routing of conduit or plumbing from the solar-ready zone to the electrical service panel or service hot water system.

**RB103.9 Electrical service reserved space.** The main electrical service panel shall have a reserved space to allow installation of a dual pole circuit breaker for future solar electric installation and shall be labeled “For Future Solar Electric.” The reserved space shall be positioned at the opposite (load) end from the input feeder location or main circuit location.

**RB103.10 Construction documentation certificate.** A permanent certificate, indicating the solar-ready zone and other requirements of this section, shall be posted near the electrical distribution panel, water heater or other conspicuous location by the builder or registered design professional.

APPENDIX RC-Reserved