

# SUBMISSION FOR PERMANENT RULE

|   |  |
|---|--|
| <b>1. Rule-Making Agency: NC Building Code Council</b>  |  |
| <b>2. Rule citation &amp; name (name not required for repeal):</b><br>2024 NC Building Code (231219 Item B-3)   |  |
| <b>3. Action:</b><br><input type="checkbox"/> ADOPTION <input checked="" type="checkbox"/> AMENDMENT <input type="checkbox"/> REPEAL <input type="checkbox"/> READOPTIOIN <input type="checkbox"/> REPEAL through READOPTIOIN   |  |
| <b>4. Rule exempt from RRC review?</b><br><input type="checkbox"/> Yes. Cite authority:<br><input checked="" type="checkbox"/> No   | <b>5. Rule automatically subject to legislative review?</b><br><input type="checkbox"/> Yes. Cite authority:<br><input checked="" type="checkbox"/> No   |
| <b>6. Notice for Proposed Rule:</b><br><input checked="" type="checkbox"/> <b>Notice Required</b><br>Notice of Text published on: January 16, 2024 in NC Register<br>Link to Agency notice: <a href="https://www.ncosfm.gov/codes/building-code-council-bcc/bcc-hearing-notice">https://www.ncosfm.gov/codes/building-code-council-bcc/bcc-hearing-notice</a><br>Hearing on: March 18, 2024<br>Adoption by Agency on: March 19, 2024<br><input type="checkbox"/> <b>Notice not required under G.S.:</b><br>Adoption by Agency on: |  |
| <b>7. Rule establishes or increases a fee? (See G.S. 12-3.1)</b><br><input type="checkbox"/> Yes<br>Agency submitted request for consultation on:<br>Consultation not required. Cite authority:<br><br><input checked="" type="checkbox"/> No   | <b>8. Fiscal impact. Check all that apply.</b><br><input type="checkbox"/> This Rule was part of a combined analysis.<br><br><input type="checkbox"/> State funds affected<br><input type="checkbox"/> Local funds affected<br><input type="checkbox"/> Substantial economic impact (≥\$1,000,000)<br><input type="checkbox"/> Approved by OSBM<br><input checked="" type="checkbox"/> No fiscal note required |
| <b>9. REASON FOR ACTION</b>   |  |
| <b>9A. What prompted this action? Check all that apply:</b><br><input checked="" type="checkbox"/> Agency<br><input type="checkbox"/> Court order / cite:<br><input type="checkbox"/> Federal statute / cite:<br><input type="checkbox"/> Federal regulation / cite:<br><input type="checkbox"/> Legislation enacted by the General Assembly<br><input type="checkbox"/> Cite Session Law:<br><input type="checkbox"/> Petition for rule-making<br><input type="checkbox"/> Other:  |  |
| <b>9B. Explain:</b> This amendment is proposed to protect the public by updating the code to current standards of practice.<br><br>The delayed effective date of this Rule is January 1, 2025.<br>The Statutory authority for Rule-making is G. S. 143-136; 143-138.  |  |
| <b>10. Rulemaking Coordinator: David B. Rittlinger</b><br>David B. Rittlinger<br>Phone: (919)647-0008<br>E-Mail: david.rittlinger@ncdoi.gov<br><br><b>Additional agency contact, if any:</b><br>Phone:<br>E-Mail:   | <b>11. Signature of Agency Head* or Rule-making Coordinator:</b><br><br><br><br><hr/> *If this function has been delegated (reassigned) pursuant to G.S. 143B-10(a), submit a copy of the delegation with this form.<br><br>Typed Name: David B. Rittlinger<br>Title: Chief Code Consultant                                |
| <b>RRC AND OAH USE ONLY</b>   |  |
| <b>Action taken:</b><br><br><input type="checkbox"/> RRC extended period of review:<br><input type="checkbox"/> RRC determined substantial changes:<br><input type="checkbox"/> Withdrawn by agency<br><input type="checkbox"/> Subject to Legislative Review<br><input type="checkbox"/> Other:  |  |

# SUBMISSION FOR PERMANENT RULE

Documents included:

1. Formatted Review Aide and 2024 North Carolina Building Code: Chapter 1 through Appendix O\*

TEXT THAT IS ~~STRUCKTHROUGH~~ IS DELETED FROM THE 2018 EDITION TO CREATE THE 2024 EDITION.

TEXT THAT IS UNDERLINED IS NEW TEXT TO CREATE THE 2024 EDITION.

\*Of note, publishing edits to the Cover page, North Carolina Building Code Council members and committees lists, North Carolina Department of Insurance contact information, Preface, Table of Contents and Index are not included as those are publishing edits that do not contain permanent rule content. These publishing edits contain NCBCC and NCDOI contact information, instructions on how to use the code, and guidance on where to find information in the code for the public-at-large. Coordination of the correct page numbers tied to the Table of Contents and Index cannot be accurately completed until the first draft of publishing is completed for NCDOI-OSFM Engineering & Codes staff review prior to completion of publishing by the International Code Council. NCDOI-OSFM Engineering & Codes staff will be coordinating the publication of all these publishing edits with the International Code Council once the proposed 2024 North Carolina Building Codes are approved.

2. Appendix C Code Change Proposal North Carolina Building Code Council (231219 Item B-3) 2024 North Carolina Building Code (File: B-3 2024 NCBC). A link to the petition can be found here: <https://www.ncosfm.gov/news/events/building-code-council-special-meeting-december-19-2023>
3. 2017-2023 Approved Amendments to the 2018 North Carolina Building Code (File: 2017-2023 Approved Amendments 230314 Building Code). A link to these amendments can be found here: <https://www.ncosfm.gov/2017-2023-approved-amendments-230314building-code>

# SUBMISSION FOR PERMANENT RULE

|  |   |
|--|---|
| <b>1. Rule-Making Agency: NC Building Code Council</b>   |   |
| <b>2. Rule citation &amp; name (name not required for repeal):</b><br>2024 NC Building Code 101.2 Scope, Exception 7 & 8 (231219 Item B-4)   |   |
| <b>3. Action:</b><br><input type="checkbox"/> ADOPTION <input checked="" type="checkbox"/> AMENDMENT <input type="checkbox"/> REPEAL <input type="checkbox"/> READOPTIOIN <input type="checkbox"/> REPEAL through READOPTIOIN  |   |
| <b>4. Rule exempt from RRC review?</b><br><input type="checkbox"/> Yes. Cite authority:<br><input checked="" type="checkbox"/> No  | <b>5. Rule automatically subject to legislative review?</b><br><input type="checkbox"/> Yes. Cite authority:<br><input checked="" type="checkbox"/> No  |
| <b>6. Notice for Proposed Rule:</b><br><input checked="" type="checkbox"/> <b>Notice Required</b><br>Notice of Text published on: January 16, 2024 in NC Register<br>Link to Agency notice: <a href="https://www.ncosfm.gov/codes/building-code-council-bcc/bcc-hearing-notice">https://www.ncosfm.gov/codes/building-code-council-bcc/bcc-hearing-notice</a><br>Hearing on: March 18, 2024<br>Adoption by Agency on: March 19, 2024<br><input type="checkbox"/> Notice not required under G.S.:<br>Adoption by Agency on: |   |
| <b>7. Rule establishes or increases a fee? (See G.S. 12-3.1)</b><br><input type="checkbox"/> Yes<br>Agency submitted request for consultation on:<br>Consultation not required. Cite authority:<br><input checked="" type="checkbox"/> No  | <b>8. Fiscal impact. Check all that apply.</b><br><input type="checkbox"/> This Rule was part of a combined analysis.<br><input type="checkbox"/> State funds affected<br><input type="checkbox"/> Local funds affected<br><input type="checkbox"/> Substantial economic impact ( $\geq$ \$1,000,000)<br><input type="checkbox"/> Approved by OSBM<br><input checked="" type="checkbox"/> No fiscal note required |
| <b>9. REASON FOR ACTION</b>  |   |
| <b>9A. What prompted this action? Check all that apply:</b><br><input checked="" type="checkbox"/> Agency<br><input type="checkbox"/> Court order / cite:<br><input type="checkbox"/> Federal statute / cite:<br><input type="checkbox"/> Federal regulation / cite:<br><input type="checkbox"/> Legislation enacted by the General Assembly<br>Cite Session Law:<br><input type="checkbox"/> Petition for rule-making<br><input type="checkbox"/> Other:  |   |
| <b>9B. Explain:</b> Includes references to N.C.G.S. 143-138(b4) and 143-138(b20) for specific scope exemptions.<br><br>The delayed effective date of this Rule is January 1, 2025.<br>The Statutory authority for Rule-making is G. S. 143-136; 143-138.   |   |
| <b>10. Rulemaking Coordinator: David B. Rittlinger</b><br>David B. Rittlinger<br>Phone: (919)647-0008<br>E-Mail: david.rittlinger@ncdoi.gov<br><br>Additional agency contact, if any:<br>Phone:<br>E-Mail:   | <b>11. Signature of Agency Head* or Rule-making Coordinator:</b><br><br><hr/> <b>*If this function has been delegated (reassigned) pursuant to G.S. 143B-10(a), submit a copy of the delegation with this form.</b><br><br>Typed Name: David B. Rittlinger<br>Title: Chief Code Consultant                                    |
| <b>RRC AND OAH USE ONLY</b>  |   |
| <b>Action taken:</b><br><input type="checkbox"/> RRC extended period of review:<br><input type="checkbox"/> RRC determined substantial changes:<br><input type="checkbox"/> Withdrawn by agency<br><input type="checkbox"/> Subject to Legislative Review<br><input type="checkbox"/> Other:   |   |

# SUBMISSION FOR PERMANENT RULE

[A] **101.2 Scope.** The provisions of this code shall apply to the construction, *alteration*, relocation, enlargement, replacement, *repair*, equipment, use and occupancy, location, maintenance, removal and demolition of every building or structure or any appurtenances connected or attached to such buildings or structures. Exception: If any of the following apply, then the building or structure is exempt from the provisions of this code:

**Exception:** If any of the following apply, then the building or structure is exempt from the provisions of this code:

....

7. Farm structures exempt by N.C.G.S 143-138(b4).

8. Buildings used for temporary motion picture, television, and theater stage sets and scenery are exempt from use and occupancy classification under the *North Carolina State Building Code* by N.C.G.S 143-138(b20).

# SUBMISSION FOR PERMANENT RULE

|   |  |
|---|--|
| <b>1. Rule-Making Agency: NC Building Code Council</b>  |  |
| <b>2. Rule citation &amp; name (name not required for repeal):</b><br>2024 NC Building Code Sections 202, 307 and 414 (231212 Item B-3)   |  |
| <b>3. Action:</b><br><input type="checkbox"/> ADOPTION <input checked="" type="checkbox"/> AMENDMENT <input type="checkbox"/> REPEAL <input type="checkbox"/> READOPTION <input type="checkbox"/> REPEAL through READOPTION   |  |
| <b>4. Rule exempt from RRC review?</b><br><input type="checkbox"/> Yes. Cite authority:<br><input checked="" type="checkbox"/> No   | <b>5. Rule automatically subject to legislative review?</b><br><input type="checkbox"/> Yes. Cite authority:<br><input checked="" type="checkbox"/> No   |
| <b>6. Notice for Proposed Rule:</b><br><input checked="" type="checkbox"/> <b>Notice Required</b><br>Notice of Text published on: January 16, 2024 in NC Register<br>Link to Agency notice: <a href="https://www.ncosfm.gov/codes/building-code-council-bcc/bcc-hearing-notice">https://www.ncosfm.gov/codes/building-code-council-bcc/bcc-hearing-notice</a><br>Hearing on: March 18, 2024<br>Adoption by Agency on: March 19, 2024<br><input type="checkbox"/> <b>Notice not required under G.S.:</b><br>Adoption by Agency on:   |  |
| <b>7. Rule establishes or increases a fee? (See G.S. 12-3.1)</b><br><input type="checkbox"/> Yes<br>Agency submitted request for consultation on:<br>Consultation not required. Cite authority:<br><input checked="" type="checkbox"/> No   | <b>8. Fiscal impact. Check all that apply.</b><br><input type="checkbox"/> This Rule was part of a combined analysis.<br><input type="checkbox"/> State funds affected<br><input type="checkbox"/> Local funds affected<br><input type="checkbox"/> Substantial economic impact (≥\$1,000,000)<br><input type="checkbox"/> Approved by OSBM<br><input checked="" type="checkbox"/> No fiscal note required |
| <b>9. REASON FOR ACTION</b>   |  |
| <b>9A. What prompted this action? Check all that apply:</b><br><input checked="" type="checkbox"/> Agency <input type="checkbox"/> Legislation enacted by the General Assembly<br><input type="checkbox"/> Court order / cite: <input type="checkbox"/> Cite Session Law:<br><input type="checkbox"/> Federal statute / cite: <input type="checkbox"/> Petition for rule-making<br><input type="checkbox"/> Federal regulation / cite: <input type="checkbox"/> Other:  |  |
| <b>9B. Explain:</b> These changes are amending the 2024 NC Building Codes to update A2L refrigerant related code provisions to align with the 2024 I-Code provisions: these amendments follow the language suggested by the ICC to amend the 2021 I-codes to include the new 2024 provisions. These changes will update the 2024 NCBC to align with the associated A2L related changes to the 2024 NCMC and to align with the chemical classifications and labeling provisions from latest edition of the Globally Harmonized System of Classification and Labeling of Chemicals.<br>The delayed effective date of this Rule is January 1, 2025. The Statutory authority for Rule-making is G. S. 143-136; 143-138. |  |
| <b>10. Rulemaking Coordinator: David B. Rittlinger</b><br>David B. Rittlinger<br>Phone: (919)647-0008<br>E-Mail: david.rittlinger@ncdoi.gov<br><br>Additional agency contact, if any:<br>Phone:<br>E-Mail:  | <b>11. Signature of Agency Head* or Rule-making Coordinator:</b><br><br><br><hr/> <b>*If this function has been delegated (reassigned) pursuant to G.S. 143B-10(a), submit a copy of the delegation with this form.</b><br><br>Typed Name: David B. Rittlinger<br>Title: Chief Code Consultant                         |
| <b>RRC AND OAH USE ONLY</b>   |  |
| <b>Action taken:</b><br><input type="checkbox"/> RRC extended period of review:<br><input type="checkbox"/> RRC determined substantial changes:<br><input type="checkbox"/> Withdrawn by agency<br><input type="checkbox"/> Subject to Legislative Review<br><input type="checkbox"/> Other:  |  |

# CHAPTER 1

## SCOPE AND ADMINISTRATION

### PART 1—SCOPE AND APPLICATION

#### SECTION 101

##### GENERAL

###### **[A] 101.1 Title.**

These regulations shall be known as the *North Carolina Existing Building Code* adopted by the North Carolina Building Code Council on June 13, ~~2017~~ 2023, to be effective January 1, ~~2019-2025~~. References to the *International Codes* shall mean the *North Carolina Codes*. The North Carolina amendments to the *International Code* are underlined.

###### **[A] 101.2 Scope.**

The provisions of ~~the *International Existing Building Code*~~ this code shall apply to the *repair, alteration, change of occupancy, addition* to and relocation of *existing buildings*.

**Exception:** Detached one- and two-family dwellings and townhouses not more than three stories above grade plane in height with a separate means of egress, and their accessory structures not more than three stories above grade plane in height, shall comply with this code or the *International Residential Code*.

###### **101.2.1 Application of fire code.** Deleted

###### **[A] 101.3 Intent Purpose .**

The intent of this code is to provide flexibility to permit the use of alternative approaches to achieve compliance with minimum requirements to safeguard the public health, safety and welfare insofar as they are affected by the *repair, alteration, change of occupancy, addition* and relocation of *existing buildings*.

###### **[A] 101.4 Applicability.**

This code shall apply to the *repair, alteration, change of occupancy, addition* and relocation of *existing buildings*, regardless of occupancy, subject to the criteria of Sections 101.4.1 and 101.4.2.

###### **[A] 101.4.1 Buildings not previously *legally occupied*.**

A building or portion of a building that has not been previously *legally occupied* or used for its intended purpose in accordance with the laws in existence at the time of its completion shall be permitted to comply with the provisions of the laws in existence at the time of its original permit unless such permit has expired. Subsequent permits shall comply with the *International Building Code* or *International Residential Code*, as applicable, for new construction.

###### **[A] 101.4.2 Buildings previously *legally occupied*.**

The legal occupancy of any building existing on the date of adoption of this code shall be permitted to

continue without change, except as is specifically covered in this code, the *International Fire Code*, or as is deemed necessary by the *code official* for the general safety and welfare of the occupants and the public.

**[A] 101.5 Safeguards during construction.**

Construction work covered in this code, including any related demolition, shall comply with the requirements of Chapter 15.

**[A] 101.6 Appendices.**

Provisions in the appendices shall not apply unless specifically adopted or referenced in this code.

**[A] 101.7 Correction of violations of other codes.**

*Repairs or alterations* mandated by any property, housing, or fire safety maintenance code or mandated by any licensing rule or ordinance adopted pursuant to law shall conform only to the requirements of that code, rule, or ordinance and shall not be required to conform to this code unless the code requiring such *repair or alteration* so provides.

**101.8 Requirements of other State agencies, occupational licensing boards or commissions.**

The North Carolina State Building Codes do not include all additional requirements for buildings and structures that may be imposed by other State agencies, occupational licensing boards and commissions. It shall be the responsibility of a permit holder, registered design professional, contractor or occupational license holder to determine whether any additional requirements exist.

**101.9 Mixed use buildings.**

Each portion of a building shall be separately classified as to use. The requirements of this code shall apply to each portion of the building based on the *occupancy classification* of that portion, except that the most restrictive requirements of this code for fire suppression shall apply to the entire building.

**Exception:** An automatic fire suppression system shall not be required for uses that would not otherwise require suppression provided that there is a 1-hour separation between the uses requiring suppression and the other uses in the same building. A 2-hour fire separation shall be required to apply this exception to Group H.

**101.10 High-rise buildings.**

*High-rise buildings* constructed prior to 1978 shall at a minimum comply with North Carolina General Statute 143-138, Section (i). The statute may be viewed at the following web address:

[http://www.ncga.state.nc.us/EnactedLegislation/Statutes/HTML/BySection/Chapter\\_143/GS\\_143-138.html](http://www.ncga.state.nc.us/EnactedLegislation/Statutes/HTML/BySection/Chapter_143/GS_143-138.html).

**101.11. Accessibility for townhouses.**

In townhouses, where there are four or more dwelling units in a single structure, the provisions for accessibility of this code for Group R-3 shall apply.

**101.12. Energy conservation exceptions.** The following exceptions apply to the *North Carolina Energy Conservation Code* provisions in existing buildings in accordance with NC General Statutes:

1. In accordance with N.C.G.S. 143-138 (b18), no energy conservation code provisions shall apply to any structure for which the primary occupancy classification IS Group F, S, or U. This exclusion shall apply to the entire building area.

2. In accordance with N.C.G.S. 143-138 (b19), for residential buildings, no energy code provisions shall apply to detached and attached garages located on the same lot as a dwelling.

## SECTION 102 APPLICABILITY

### **[A] 102.1 General.**

Where there is a conflict between a general requirement and a specific requirement, the specific requirement shall be applicable. Where in any specific case different sections of this code specify different materials, methods of construction or other requirements, the most restrictive shall govern.

### **[A] 102.2 Other laws.**

The provisions of this code shall not be deemed to nullify any provisions of local, state, or federal law.

### **[A] 102.3 Application of references.**

References to chapter or section numbers or to provisions not specifically identified by number shall be construed to refer to such chapter, section, or provision of this code.

### **[A] 102.4 Referenced codes and standards.**

The codes and standards referenced in this code shall be considered part of the requirements of this code to the prescribed extent of each such reference and as further regulated in Sections 102.4.1 and 102.4.2.

**Exception:** Where enforcement of a code provision would violate the conditions of the listing of the equipment or appliance, the conditions of the listing shall govern.

#### **[A] 102.4.1 Conflicts.**

Where conflicts occur between provisions of this code and referenced codes and standards, the provisions of this code shall apply.

#### **[A] 102.4.2 Conflicting provisions.**

Where the extent of the reference to a referenced code or standard includes subject matter that is within the scope of this code, the provisions of this code as applicable, shall take precedence over the provisions in the referenced code or standard.



**[A] 102.5 Partial invalidity.**

In the event that any part or provision of this code is held to be illegal or void, this shall not have the effect of making void or illegal any of the other parts or provisions.

**PART 2—ADMINISTRATION AND ENFORCEMENT**

**SECTION 103  
DEPARTMENT OF BUILDING SAFETY**

Deleted. See the *North Carolina Administrative Code and Policies*.

**SECTION 104  
DUTIES AND POWERS OF CODE OFFICIAL**

**104.1 General through 104.9 Approved materials and equipment.**

Deleted. See the *North Carolina Administrative Code and Policies*.

**[A] 104.2 Applications and permits.** Deleted. See the *North Carolina Administrative Code and Policies*.

**[A] 104.3 Notices and orders.** Deleted. See the *North Carolina Administrative Code and Policies*.

**[A] 104.4 Inspections.** Deleted. See the *North Carolina Administrative Code and Policies*.

**[A] 104.5 Identification.** Deleted. See the *North Carolina Administrative Code and Policies*.

**[A] 104.6 Right of entry.** Deleted. See the *North Carolina Administrative Code and Policies*.

**[A] 104.7 Department records.** Deleted. See the *North Carolina Administrative Code and Policies*.

**[A] 104.8 Liability.** Deleted. See the *North Carolina Administrative Code and Policies*.

**[A] 104.9 Approved materials and equipment.** Deleted. See the *North Carolina Administrative Code and Policies*.

**[A] 104.10 Modifications.**

Wherever there are practical difficulties involved in carrying out the provisions of this code, the *code official* shall have the authority to grant modifications for individual cases upon application of the owner or owner's

authorized representative, provided the *code official* shall first find that special individual reason makes the strict letter of this code impractical, the modification is in compliance with the intent and purpose of this code and such modification does not lessen health, accessibility, life and fire safety, or structural requirements. The details of action granting modifications shall be recorded and entered in the files of the Department of Building Safety.

**[A] 104.10.1 Flood hazard areas.**

For *existing buildings* located in *flood hazard areas* for which *repairs, alterations* and *additions* constitute *substantial improvement*, the *code official* shall not grant modifications to provisions related to flood resistance unless a determination is made that:

1. The applicant has presented good and sufficient cause that the unique characteristics of the size, configuration or topography of the site render compliance with the flood-resistant construction provisions inappropriate.
2. Failure to grant the modification would result in exceptional hardship.
3. The granting of the modification will not result in increased flood heights, additional threats to public safety, extraordinary public expense nor create nuisances, cause fraud on or victimization of the public or conflict with existing laws or ordinances.
4. The modification is the minimum necessary to afford relief, considering the flood hazard.
5. A written notice will be provided to the applicant specifying, if applicable, the difference between the design flood elevation and the elevation to which the building is to be built, stating that the cost of flood insurance will be commensurate with the increased risk resulting from the reduced floor elevation and that construction below the design flood elevation increases risks to life and property.

Local ordinances more restrictive than the requirements of this section supersede these requirements.

**[A] 104.11 Alternative materials, design and methods of construction, and equipment.**

The provisions of this code are not intended to prevent the installation of any material or to prohibit any design or method of construction not specifically prescribed by this code, provided that any such alternative has been approved. An alternative material, design, or method of construction shall be approved where the *code official* finds that the proposed design is satisfactory and complies with the intent of the provisions of this code, and that the material, method, or work offered is, for the purpose intended, not less than the equivalent of that prescribed in this code in quality, strength, effectiveness, fire resistance, durability and safety. Where the alternative material, design or method of construction is not approved, the *code official* shall respond in writing, stating the reasons the alternative was not approved.

**[A] 104.11.1 Research reports.**

Supporting data, where necessary to assist in the approval of materials or assemblies not specifically provided for in this code, shall consist of valid research reports from approved sources.

**[A] 104.11.2 Tests.**

Whenever there is insufficient evidence of compliance with the provisions of this code or evidence that a

material or method does not conform to the requirements of this code, or in order to substantiate claims for alternative materials or methods, the *code official* shall have the authority to require tests as evidence of compliance to be made at no expense to the jurisdiction. Test methods shall be as specified in this code or by other recognized test standards. In the absence of recognized and accepted test methods, the *code official* shall approve the testing procedures. Tests shall be performed by an approved agency. Reports of such tests shall be retained by the *code official* for the period required for retention.

## **SECTION 105 PERMITS**

Deleted. See the *North Carolina Administrative Code and Policies*.

## **SECTION 106 CONSTRUCTION DOCUMENTS**

Deleted. See the *North Carolina Administrative Code and Policies*.

## **SECTION 107 TEMPORARY STRUCTURES AND USES**

Deleted. See the *North Carolina Administrative Code and Policies*.

## **SECTION 108 FEES**

Deleted. See the *North Carolina Administrative Code and Policies*.

## **SECTION 109 INSPECTIONS**

Deleted. See the *North Carolina Administrative Code and Policies*.

## **SECTION 110 CERTIFICATE OF OCCUPANCY**

Deleted. See the *North Carolina Administrative Code and Policies*.

**SECTION 111  
SERVICE UTILITIES**

Deleted. See the *North Carolina Administrative Code and Policies*.

**SECTION 112  
~~BOARD~~ MEANS OF APPEALS**

Deleted. See the *North Carolina Administrative Code and Policies*.

**SECTION 113  
VIOLATIONS**

Deleted. See the *North Carolina Administrative Code and Policies*.

**SECTION 114  
STOP WORK ORDER**

Deleted. See the *North Carolina Administrative Code and Policies*.

**SECTION 115  
UNSAFE BUILDINGS AND EQUIPMENT**

Deleted. See the *North Carolina Administrative Code and Policies*.

**SECTION 116  
EMERGENCY MEASURES**

Deleted. See the *North Carolina Administrative Code and Policies*.

## **SECTION 117 DEMOLITION**

Deleted. See the *North Carolina Administrative Code and Policies*.

# **CHAPTER 2 DEFINITIONS**

## **SECTION 201 GENERAL**

### **201.1 Scope.**

Unless otherwise expressly stated, the following words and terms shall, for the purposes of this code, have the meanings shown in this chapter.

### **201.2 Interchangeability.**

Words used in the present tense include the future; words stated in the masculine gender include the feminine and neuter; the singular number includes the plural and the plural, the singular.

### **201.3 Terms defined in other codes.**

Where terms are not defined in this code and are defined in the other *International Codes*, such terms shall have the meanings ascribed to them in those codes.

### **201.4 Terms not defined.**

Where terms are not defined through the methods authorized by this chapter, such terms shall have ordinarily accepted meanings such as the context implies.

## **SECTION 202 GENERAL DEFINITIONS**

**ADDITION.** An extension or increase in floor area, number of stories, or height of a building or structure.

**ALTERATION.** Any construction or renovation to an existing structure other than a *repair* or *addition*. Alterations are classified as Level 1, Level 2, and Level 3.

**[A] APPROVED.** Acceptable to the *code official* or authority having jurisdiction for compliance with the provisions of the applicable code or reference.

**BOARDING HOUSE.** A building arranged or used for lodging for compensation, with or without meals, and not occupancies as a single-family unit.

**CARBON MONOXIDE ALARM.** A single- or multiple-station alarm intended to detect carbon monoxide gas and alert occupants by a distinct audible signal. It incorporates a sensor, control components and an alarm notification appliance in a single unit.

**CARBON MONOXIDE DETECTOR.** A device with an integral sensor to detect carbon monoxide gas and transmit an alarm signal to a connected alarm control unit

**[A] CHANGE OF OCCUPANCY.** ~~A change in the use of the building or a portion of a building. A change of occupancy shall include any change of occupancy classification, any change from one group to another group within an occupancy classification or any change in use within a group for a specific occupancy classification.~~ Any of the following shall be considered as a change of occupancy where the current International Building Code requires a greater degree of safety, accessibility, structural strength, fire protection, means of egress, ventilation or sanitation than is existing in the current building or structure:

1. Any change in the occupancy classification.
2. Any change from one group to another group within an occupancy classification.
3. Any change in use within a group for which there is a change in application of the requirements of this code.

**[A] CHANGE OF USE.** A change in the use of a building or a portion of a building, within the same group classification, for which there is a change in application of the code requirements.

**[A] CODE OFFICIAL.** The officer or other designated authority charged with the administration and enforcement of this code.

**COMMERCIAL BUILDING.** For energy conservation provisions, all buildings that are not included in the definition of “Residential Building.”.

**[BS] DANGEROUS.** Any building, structure or portion thereof that meets any of the conditions described below shall be deemed dangerous:

1. The building or structure has collapsed, has partially collapsed, has moved off its foundation, or lacks the necessary support of the ground.
2. There exists a significant risk of collapse, detachment or dislodgement of any portion, member, appurtenance or ornamentation of the building or structure under service loads.

**[BS] DISPROPORTIONATE EARTHQUAKE DAMAGE.** A condition of earthquake-related damage where both of the following occur:

1. The 0.3-second spectral acceleration at the building site as estimated by the United States Geological Survey for the earthquake in question is less than 40 percent of the mapped acceleration parameter SS.
2. The vertical elements of the lateral force-resisting system have suffered damage such that the lateral load-carrying capacity of any story in any horizontal direction has been reduced by more than 10 percent from its predamage condition.

**[BE] EMERGENCY ESCAPE AND RESCUE OPENING.** An operable exterior window, door or other similar device that provides for a means of escape and access for rescue in the event of an emergency.

**EQUIPMENT OR FIXTURE.** Any plumbing, heating, electrical, ventilating, air conditioning, refrigerating, and fire protection equipment, and elevators, dumb waiters, escalators, boilers, pressure vessels and other mechanical facilities or installations that are related to building services. Equipment or fixture shall not include manufacturing, production, or process equipment, but shall include connections from building service to process equipment.

**EXISTING BUILDING.** A building *legally occupied* or *legally occupied* prior to a current vacant status

**[A] EXISTING STRUCTURE.** A structure erected prior to the date of adoption of the appropriate code, or one for which a legal building permit has been issued.

**[BF] EXTERIOR WALL COVERING.** A material or assembly of materials applied on the exterior side of exterior walls for the purpose of providing a weather-resisting barrier, insulation or for aesthetics, including but not limited to, veneers, siding, exterior insulation and finish systems, architectural trim and embellishments, such as cornices, soffits, fascias, gutters and leaders.

**[BF] EXTERIOR WALL ENVELOPE.** A system or assembly of exterior wall components, including exterior wall finish materials, that provides protection of the building structural members, including framing and sheathing materials, and conditioned interior space from the detrimental effects of the exterior environment.

**[A] FACILITY.** All or any portion of buildings, structures, site improvements, elements and pedestrian or vehicular routes located on a site.

**[BS] FLOOD HAZARD AREA.** The greater of the following two areas:

1. The area within a flood plain subject to a 1-percent or greater chance of flooding in any year.
2. The area designated as a *flood hazard area* on a community's flood hazard map, or otherwise legally designated.

**HIGH-RISE BUILDING.** A building with an occupied floor located more than 75 feet above the lowest level of fire department vehicle access.

**[A] HISTORIC BUILDING.** Any building or structure that is one or more of the following:



1. Listed, or certified as eligible for listing, by the State Historic Preservation Officer or the Keeper of the National Register of Historic Places, in the National Register of Historic Places.
2. Designated as historic or contributing resource under an applicable state or local law.
3. Certified as a contributing resource within a National Register, state designated or locally designated historic district.

**LEGALLY OCCUPIED.** A building that has a current certificate of occupancy or equivalent documentation provided by the permit holder acceptable to the local code enforcement official.

**LISTED.** Equipment, materials, products or services included in a list published by an organization acceptable to the code official and concerned with evaluation of products or services that maintain periodic inspections of production of listed equipment or materials or periodic evaluation of services and whose listing states either that the equipment, material, product or service meets identified standards or has been tested and found suitable for a specified purpose.

~~**LOAD BEARING ELEMENT.** Any column, girder, beam, joist, truss, rafter, wall, floor or roof sheathing that supports any vertical load in addition to its own weight or any lateral load.~~

**NIGHT CLUB.** An A-2 occupancy meeting all of the following conditions:

1. The aggregate floor area of concentrated use and standing space that is used for dancing or viewing of performers exceeds 10 percent of the Group A-2 fire area, excluding adjacent lobby areas ; and
2. Provides live or recorded entertainment by performing artist; and
3. Allows alcoholic beverage consumption.

**NONCOMBUSTIBLE MATERIAL.** A material that, under the conditions anticipated, will not ignite or burn when subjected to fire or heat. Materials that pass ASTM E 136 are considered noncombustible materials.

**OCCUPANCY CLASSIFICATION.** A subset of the occupancy group as listed in Chapter 3 of the *North Carolina Building Code* (i.e., A-1, A-2, A-3, A-4, A-5, B, E, F-1, F-2, H-1, H-2, H-3, H-4, H-5, I-1, I-2, I-3, I-4, M, R-1, R-2, R-3, R-4, S-1, S-2, and U).

**OCCUPANCY GROUP.** Occupant type as listed in Chapter 3 of the *North Carolina Building Code* (i.e., A, B, E, F, H, I, M, R, S, U).

**OCCUPANCY USE.** The function of the space and not necessarily the *occupancy classification*.

**OPERATIONAL ACCESS.** Building access which allows use of a building during and after an emergency event.

**PRIMARY FUNCTION.** A *primary function* is a major activity for which the facility is intended. Areas that contain a *primary function* include, but are not limited to, the customer services lobby of a bank, the dining area of a cafeteria, the meeting rooms in a conference center, as well as offices and other work areas in which the activities of the public accommodation or other private entity using the facility are carried out. Mechanical rooms, boiler rooms, supply storage rooms, employee lounges or locker rooms, janitorial closets, entrances, corridors and restrooms are not areas containing a *primary function*.

**[B] REGISTERED DESIGN PROFESSIONAL.** An individual who is registered or licensed to practice their respective design profession as defined by the statutory requirements of the professional registration laws of the state or jurisdiction in which the project is to be constructed. A design by a registered design professional is not required where exempt under the registration or license laws.

**REHABILITATION.** Any work, as described by the categories of work defined herein, undertaken in an *existing building*.

**[A] RELOCATABLE BUILDING.** A partially or completely assembled building constructed and designed to be reused multiple times and transported to different building sites.

~~**REHABILITATION, SEISMIC.** Work conducted to improve the seismic lateral force resistance of an *existing building*.~~

**[A] REPAIR.** The restoration or renewal of any part of an *existing building* for the purpose of its maintenance or to correct damage.

**[BS] REROOFING.** The process of recovering or replacing an existing roof covering. See “Roof recover” and “Roof replacement.”

**RESIDENTIAL BUILDING.** For energy conservation provisions, includes detached one- and two- family dwellings and multiple single-family dwellings (townhouses) as well as Group R-2, R-3, and R-4 buildings three or less in height above grade plane.

**[BS] RISK CATEGORY.** A categorization of buildings and other structures for determination of flood, wind, snow, ice and earthquake loads based on the risk associated with unacceptable performance, as provided in Section 1604.5 of the *International Building Code*.

**[BS] ROOF COATING.** A fluid-applied adhered coating used for roof maintenance, *roof repair* or as a component of a roof covering system or roof assembly.

**[BS] ROOF RECOVER.** The process of installing an additional roof covering over a prepared existing roof covering without removing the existing roof covering.

**[BS] ROOF REPAIR.** Restoration or renewal of any part of an existing roof for the purposes of its maintenance.

**[BS] ROOF REPLACEMENT.** The process of removing the existing roof covering, repairing any damaged substrate and installing a new roof covering.

~~**SEISMIC LOADING.** The forces prescribed herein, related to the response of the structure to earthquake motions, to be used in the analysis and design of the structure and its components.~~

**[BS] SEISMIC FORCES.** The loads, forces and requirements prescribed herein, related to the response of the building to earthquake motions, to be used in the analysis and design of the structure and its components. Seismic forces are considered either full or reduced, as provided in Chapter 3.

**[BS] SUBSTANTIAL DAMAGE.** For the purpose of determining compliance with the flood provisions of this code, damage of any origin sustained by a structure whereby the cost of restoring the structure to its before-damaged condition would equal or exceed 50 percent of the market value of the structure before the damage occurred.

**[BS] SUBSTANTIAL IMPROVEMENT.** For the purpose of determining compliance with the flood provisions of this code, any *repair, alteration, addition*, or improvement of a building or structure, the cost of which equals or exceeds 50 percent of the market value of the structure, before the improvement or *repair* is started. If the structure has sustained *substantial damage*, any repairs are considered *substantial improvement* regardless of the actual *repair* work performed. The term does not, however, include either:

1. Any project for improvement of a building required to correct existing health, sanitary, or safety code violations identified by the *code official* and that is the minimum necessary to ensure safe living conditions; or
2. Any *alteration* of a historic structure, provided that the *alteration* will not preclude the structure's continued designation as a historic structure.

**[BS] SUBSTANTIAL STRUCTURAL ALTERATION.** An *alteration* in which the *gravity load-carrying structural elements* altered within a 5-year period support more than 30 percent of the total floor and roof area of the building or structure. The areas to be counted toward the 30 percent shall include *mezzanines, penthouses, and in-filled courts and shafts tributary to the altered structural elements.*

**[BS] SUBSTANTIAL STRUCTURAL DAMAGE.** A condition where one or both of the following apply:

1. The vertical elements of the lateral force-resisting system have suffered damage such that the lateral load-carrying capacity of the structure in any horizontal direction has been reduced by more than 33 percent from its predamage condition.

2. The capacity of any vertical gravity load-carrying component, or any group of such components, that supports more than 30 percent of the total area of the structure's floor(s) and roof(s) has been reduced more than 20 percent from its predamage condition and the remaining capacity of such affected elements, with respect to all dead and live loads, is less than 75 percent of that required by this code for new buildings of similar structure, purpose and location

**SYSTEM.** Primary structural, mechanical, plumbing, electrical, fire protection, or occupant service components of a building including any equipment, fixtures, connections, conduits, wires, pipes, ducts, as well as any associated sensors, controls, distribution or safety elements.

**TECHNICALLY INFEASIBLE.** An *alteration* of a facility that a registered design professional and code official agree has little likelihood of being accomplished because the existing structural conditions require the removal or *alteration* of a load-bearing member that is an essential part of the structural frame, or because other existing physical or site constraints prohibit modification or addition of elements, spaces or features which are in full and strict compliance with the minimum requirements for new construction and which are necessary to provide accessibility.

**TEMPORARY OVEFLOW SHELTER.** A shelter that provides temporary overflow accommodations from an approved homeless shelter in accordance with Section 411.

**UNSAFE.** See the *North Carolina Administrative Code and Policies*

**WORK AREA.** That portion or portions of a building consisting of all reconfigured spaces as indicated on the construction documents. Work area excludes other portions of the building where incidental work entailed by the intended work must be performed and portions of the building where work not initially intended by the owner is specifically required by this code.

## **CHAPTER 3**

# **PROVISIONS FOR ALL COMPLIANCE METHODS**

## SECTION 301 ADMINISTRATION

### **301.1-~~General.~~ Applicability**

The *repair, alteration, change of occupancy, addition* or relocation of all *existing buildings* shall comply with ~~one~~ of the methods listed in Sections 301.1.1 through 301.1.3 as selected by the applicant. Sections 301.1.1 through 301.1.3 shall not be applied in combination with each other. Where this code requires consideration of the seismic force-resisting system of an *existing building* subject to *repair, alteration, change of occupancy, addition* or relocation of *existing buildings*, the seismic evaluation and design shall be based on Section 301.1.4 regardless of which compliance method is used. Section 301.2, 301.3 or 301.4. [The provisions of Sections 302 through 309 shall apply to all alterations, repairs, additions, relocation of structures and changes of occupancy regardless of compliance method.](#)

**Exception:** Structural *alterations* complying with the laws in existence at the time the building or the affected portion of the building was built shall be considered in compliance with the provisions of this code unless the building is undergoing more than a limited structural *alteration* as defined in Section 907.4.4. New structural members added as part of the *alteration* shall comply with the *International Building Code*. *Alterations of existing buildings in flood hazard areas* shall comply with Section 701.3. Buildings constructed prior to the existence of an applicable *North Carolina State Building Code* and in structurally sound condition shall be considered “complying with the laws in existence at the time the building or the affected portion of the building was built”.

#### **301.1.1-~~Prescriptive compliance method.~~**

~~*Repairs, alterations, additions and changes of occupancy* complying with Chapter 4 of this code in buildings complying with the *International Fire Code* shall be considered in compliance with the provisions of this code.~~

Bleachers, grandstands and folding and telescopic seating.

Existing bleachers, grandstands and folding and telescopic seating shall comply with ICC 300.

#### **301.1.2-~~Work area compliance method.~~**

~~*Repairs, alterations, additions, changes in occupancy and relocated buildings* complying with the applicable requirements of Chapters 5 through 13 of this code shall be considered in compliance with the provisions of this code.~~

#### **301.1.3-~~Performance compliance method.~~**

~~*Repairs, alterations, additions, changes in occupancy and relocated buildings* complying with Chapter 14 of this code shall be considered in compliance with the provisions of this code.~~

#### **[BS] 301.1.4-~~Seismic evaluation and design procedures.~~**

The seismic evaluation and design shall be based on the procedures specified in the *International Building Code* or ASCE 41. The procedures contained in Appendix A of this code shall be permitted to be used as specified in Section 301.1.4.2.

**Exception:** Seismic requirements shall not apply to detached one- and two-family dwellings.

**[BS] 301.1.4.1 Compliance with International Building Code-level seismic forces.**

Where compliance with the seismic design provisions of the *International Building Code* is required, the criteria shall be in accordance with one of the following:

1. One hundred percent of the values in the International Building Code. Where the existing seismic force-resisting system is a type that can be designated as “Ordinary,” values of  $R$ ,  $\Omega_0$  and  $C_d$  used for analysis in accordance with Chapter 16 of the International Building Code shall be those specified for structural systems classified as “Ordinary” in accordance with Table 12.2-1 of ASCE 7, unless it can be demonstrated that the structural system will provide performance equivalent to that of a “Detailed,” “Intermediate” or “Special” system.
2. ASCE 41, using a Tier 3 procedure and the two-level performance objective in Table 301.1.4.1 for the applicable risk category.

**[BS] TABLE 301.1.4.1  
PERFORMANCE OBJECTIVES FOR USE IN ASCE 41 FOR COMPLIANCE WITH  
INTERNATIONAL BUILDING CODE-LEVEL SEISMIC FORCES**

| RISK CATEGORY<br>(Based on IBC Table<br>1604.5) | STRUCTURAL PERFORMANCE LEVEL FOR<br>USE<br>WITH BSE-1N EARTHQUAKE HAZARD<br>LEVEL | STRUCTURAL PERFORMANCE LEVEL FOR<br>USE<br>WITH BSE-2N EARTHQUAKE HAZARD<br>LEVEL |
|---|---|---|
| I   | Life Safety (S-3)   | Collapse Prevention (S-5)   |
| II  | Life Safety (S-3)   | Collapse Prevention (S-5)   |
| III   | Damage Control (S-2)  | Limited Safety (S-4)  |
| IV  | Immediate Occupancy (S-1)   | Life Safety (S-3)   |

**[BS] 301.1.4.2 Compliance with reduced International Building Code-level seismic forces.**

Where seismic evaluation and design is permitted to meet reduced *International Building Code* seismic force levels, the criteria used shall be in accordance with one of the following:

1. The *International Building Code* using 75 percent of the prescribed forces. Values of  $R$ ,  $\Omega_0$  and  $C_d$  used for analysis shall be as specified in Section 301.1.4.1 of this code.
2. Structures or portions of structures that comply with the requirements of the applicable chapter in Appendix A as specified in Items 2.1 through 2.5 and subject to the limitations of the respective Appendix A chapters shall be deemed to comply with this section.
  - 2.1. The seismic evaluation and design of unreinforced masonry bearing wall buildings in Risk Category I or II are permitted to be based on the procedures specified in Appendix Chapter A1.

- ~~2.2. Seismic evaluation and design of the wall anchorage system in reinforced concrete and reinforced masonry wall buildings with flexible diaphragms in Risk Category I or II are permitted to be based on the procedures specified in Chapter A2.~~
- ~~2.3. Seismic evaluation and design of cripple walls and sill plate anchorage in residential buildings of light-frame wood construction in Risk Category I or II are permitted to be based on the procedures specified in Chapter A3.~~
- ~~2.4. Seismic evaluation and design of soft, weak, or open-front wall conditions in multiunit residential buildings of wood construction in Risk Category I or II are permitted to be based on the procedures specified in Chapter A4.~~
- ~~2.5. Seismic evaluation and design of concrete buildings assigned to Risk Category I, II or III are permitted to be based on the procedures specified in Chapter A5.~~
- ~~3. ASCE 41, using the performance objective in Table 301.1.4.2 for the applicable risk category.~~

**[BS] TABLE 301.1.4.2  
PERFORMANCE OBJECTIVES FOR USE IN ASCE 41 FOR COMPLIANCE WITH  
REDUCED INTERNATIONAL BUILDING CODE-LEVEL SEISMIC FORCES**

| RISK CATEGORY<br>(Based on IBC Table<br>1604.5) | STRUCTURAL PERFORMANCE LEVEL FOR USE WITH BSE 1E EARTHQUAKE HAZARD<br>LEVEL |
|---|---|
| I   | Life Safety (S-3)   |
| II  | Life Safety (S-3)   |
| III   | Damage Control (S-2). See Note a  |
| IV  | Immediate Occupancy (S-1)   |

- a. Tier 1 evaluation at the Damage Control performance level shall use the Tier 1 Life Safety checklists and Tier 1 Quick Check provisions midway between those specified for Life Safety and Immediate Occupancy performance.

**301.2 Repairs.** *Repairs* shall comply with the requirements of Chapter 4.

**301.3 Alteration, addition or change of occupancy.** *The alteration, addition or change of occupancy of all existing buildings shall comply with one of the methods listed in Section 301.3.1, 301.3.2 or 301.3.3 as selected by the applicant. Sections 301.3.1 through 301.3.3 shall not be applied in combination with each other.*



**Exception:** Subject to the approval of the *code official*, alterations complying with the laws in existence at the time the building or the affected portion of the building was built shall be considered in compliance with the provisions of this code. Buildings constructed prior to the existence of an applicable *North Carolina State Building Code* and in structurally sound condition shall be considered complying with the laws in existence at the time the building or the affected portion of the building was built. New structural members added as part of the *alteration* shall comply with the *International Building Code*. This exception shall not apply to the following:

1. Alterations for accessibility required by Section 306.
2. Alterations that constitute *substantial improvement in flood hazard areas*, which shall comply with Sections 503.2, 701.3 or 1301.3.3.
3. Structural provisions of Section 304, Chapter 5 or to the structural provisions of Sections 706, 805 and 906.

**301.3.1 Prescriptive compliance method.** Alterations, additions and changes of occupancy complying with Chapter 5 of this code in buildings complying with the *International Fire Code* shall be considered in compliance with the provisions of this code.

**301.3.2 Work area compliance method.** Alterations, additions and changes of occupancy complying with the applicable requirements of Chapters 6 through 12 of this code shall be considered in compliance with the provisions of this code.

**301.3.3 Performance compliance method.** Alterations, additions and changes of occupancy complying with Chapter 13 of this code shall be considered in compliance with the provisions of this code.

**301.4 Relocated buildings.** Relocated buildings shall comply with the requirements of Chapter 14.

## SECTION 302 GENERAL PROVISIONS

### **302.1 Applicability.**

~~The provisions of Section 302 apply to all alterations, repairs, additions, relocations of structures and changes of occupancy regardless of compliance method.~~

**302.1 Dangerous conditions.** The *code official* shall have the authority to require the elimination of conditions deemed *dangerous*.

### **302.2 Additional codes.**

*Alterations, repairs, additions and changes of occupancy* to, or relocation of, *existing buildings* and structures shall comply with the provisions for *alterations, repairs, additions and changes of occupancy* or relocation, respectively, in this code and the *International Energy Conservation Code, International Fire Code, International Fuel Gas Code, International Mechanical Code, International Plumbing Code, International Residential Code* and ~~NFPA 70~~. Where provisions of the other codes conflict with provisions of this code, the provisions of this code shall take precedence.

**302.2.1 Additional codes in health care.** In existing Group I-2 occupancies, ambulatory health care *facilities*, outpatient clinics and hyperbaric *facilities*, alterations, repairs, additions and changes of occupancy to, or relocation of, *existing buildings* and structures shall also comply with NFPA 99.

### **302.3 Existing materials.**

Materials already in use in a building in compliance with requirements or approvals in effect at the time of their erection or installation shall be permitted to remain in use unless determined by the building code official to be unsafe.

### **302.4 New and replacement materials.**

Except as otherwise required or permitted by this code, materials permitted by the applicable code for new construction shall be used. Like materials shall be permitted for *repairs* and *alterations*, provided that *unsafe* conditions are not created. Hazardous materials shall not be used where the code for new construction would not permit their use in buildings of similar occupancy, purpose and location.

**[BS] 302.4.1 New structural members and connections.** New structural members and connections shall comply with the detailing provisions of the *International Building Code* for new buildings of similar structure, purpose and location.

**Exception:** Where alternative design criteria are specifically permitted.

### **302.5 Occupancy and use.**

Where determining the appropriate application of the referenced sections of this code, the occupancy and use of a building shall be determined in accordance with Chapter 3 of the *International Building Code*.

## **SECTION 303** **STORM SHELTERS**

**303.1 Storm shelters.** This section applies to the construction of storm shelters constructed as rooms or spaces within *existing buildings* for the purpose of providing protection during storms that produce high winds, such as tornados and hurricanes. Such structures shall be designated to be hurricane shelters, tornado shelters, or combined hurricane and tornado shelters. Such structures shall be constructed in accordance with the *International Building Code*.

**\*\* 303.2 Addition to a Group E occupancy.** Deleted

## **SECTION 304** **STRUCTURAL DESIGN LOADS AND EVALUATION AND DESIGN PROCEDURES**

**[BS] 304.1 Live loads.** Where an *addition* or *alteration* does not result in increased design live load, existing gravity load-carrying structural elements shall be permitted to be evaluated and designed for live loads *approved* prior to the *addition* or *alteration*. If the *approved* live load is less than that required by Section 1607 of the *International Building Code*, the area designated for the nonconforming live load shall be posted with placards of *approved* design indicating the *approved* live load. Where the *addition* or *alteration* results in increased design live load, the live load required by Section 1607 of the *International Building Code* shall be used.

**[BS] 304.2 Snow loads on adjacent buildings.** Where an *alteration* or *addition* changes the potential snow drift effects on an adjacent building, the *code official* is authorized to enforce Section 7.12 of ASCE 7.

**[BS] 304.3 Seismic evaluation and design procedures. Deleted.**

## **SECTION 305** **IN-SITU LOAD TESTS**

**[BS] 305.1 General.** Where used, in-situ load tests shall be conducted in accordance with Section 1708 of the *International Building Code*.

## **SECTION 306** **ACCESSIBILITY FOR EXISTING BUILDINGS**

**306.1 Scope.** The provisions of Sections 306.1 through 306.7.16 apply to maintenance and *repair, change of occupancy, additions and alterations to existing buildings*, including those identified as *historic buildings*.

**Exception:** Repairs in accordance with Chapter 4 and Level 1 Alterations in accordance with Chapter 7 that do not reduce the level of accessibility that exists prior to work shall be exempt from the requirements of this section.

**306.2 Design.** Buildings and *facilities* shall be designed and constructed to be accessible in accordance with this code and the *alteration and existing building* provisions in ICC A117.1, as applicable.

(Re-visit after the review of IBC Chapter 11)

**306.3 Maintenance and repair.** A *facility* that is constructed or altered to be accessible shall be maintained accessible during occupancy. Required accessible means of egress shall be maintained during construction, demolition, remodeling or *alterations and additions* to any occupied building.

Exception: Existing means of egress need not be maintained where *approved* temporary means of egress and accessible means of egress systems and *facilities* are provided.

**306.3.1 Prohibited reduction in accessibility.** An *alteration* that decreases or has the effect of decreasing accessibility of a building, *facility* or element, thereof, below the requirements for new construction at the time of the *alteration* is prohibited. The number of accessible elements need not exceed that required for new construction at the time of *alteration*.

**306.3.2 Fuel dispensers.** Operable parts of replacement fuel dispensers shall be permitted to be 54 inches (1370 mm) maximum measured from the surface of the vehicular way where fuel dispensers are installed on existing curbs.

**306.4 Extent of application.** An *alteration* of an existing *facility* shall not impose a requirement for greater accessibility than that which would be required for new construction.

**306.5 Change of occupancy.** *Existing buildings* that undergo a change of group or occupancy shall comply with Section 306.7. Where an entire building undergoes a change of occupancy, shall have all of the following accessible features:

1. At least one accessible building entrance.
2. At least one accessible route from an accessible building entrance to *primary function* areas.
3. Signage complying with Section 1112 of the *International Building Code*.
4. Accessible parking, where parking is being provided.
5. At least one accessible passenger loading zone, when loading zones are provided.
6. At least one accessible route connecting accessible parking and accessible passenger loading zones to an accessible entrance.

**Exception:**

1. Type B dwelling or sleeping units required by Section 1108 of the *International Building Code* are not required to be provided in *existing buildings* and *facilities* undergoing a *change of occupancy* in conjunction with *alterations* where the *work area* is 50 percent or less of the aggregate area of the building.
2. The accessible features listed in Items 1 through 6 are not required for an accessible route to Type B units.
3. Where it is *technically infeasible* to comply with the new construction standards for any of these requirements for a *change of group or occupancy*, the above items shall conform to the requirements to the maximum extent *technically feasible*.

**306.6 Additions.** Provisions for new construction shall apply to *additions*. An *addition* that affects the accessibility to, or contains an area of, a *primary function* shall comply with the requirements in Section 306.7.1.

**306.7 Alterations.** A *facility* that is altered shall comply with the applicable provisions in Chapter 11 of the *International Building Code*, ICC A117.1 and the provisions of Sections 306.7.1 through 306.7.16, unless *technically infeasible*. Where compliance with this section is *technically infeasible*, the *alteration* shall provide access to the maximum extent technically feasible. \_\_\_\_\_

(Re-Visit after the review of Chapter 11 NCBC)

**306.7.1 Alterations affecting an area containing a primary function.** Where an *alteration* affects the accessibility to, or contains an area of *primary function*, the route to the *primary function* area shall be accessible. The accessible route to the *primary function* area shall include toilet *facilities* and drinking fountains serving the area of *primary function*.

**Exceptions:**

1. The costs of providing the accessible route are not required to exceed 20 percent of the costs of the *alterations* affecting the area of *primary function*.
2. This provision does not apply to *alterations* limited solely to windows, hardware, operating controls, electrical outlets and signs.
3. This provision does not apply to *alterations* limited solely to mechanical systems, electrical systems, installation or *alteration* of fire protection systems and abatement of hazardous materials.
4. This provision does not apply to *alterations* undertaken for the primary purpose of increasing the accessibility of a *facility*.

5. This provision does not apply to altered areas limited to Type B dwelling and sleeping units.

306.7.2 Accessible means of egress. Accessible means of egress required by Chapter 10 of the *International Building Code* are not required to be added in existing *facilities*.

306.7.3 Alteration of Type A units. The *alteration* to Type A individually owned dwelling units within a Group R-2 occupancy shall be permitted to meet the provision for a Type B dwelling unit.

306.7.4 Type B units. Type B dwelling or sleeping units required by Section 1108 of the *International Building Code* are not required to be provided in *existing buildings* and *facilities* undergoing *alterations* where the *work area* is 50 percent or less of the aggregate area of the building.

306.7.5 Entrances. Where an *alteration* includes *alterations* to an entrance that is not accessible, and the *facility* has an accessible entrance, the altered entrance is not required to be accessible unless required by Section 306.7.1. Signs complying with Section 1112 of the *International Building Code* shall be provided.

306.7.6 Accessible route. Exterior accessible routes, including curb ramps, shall be not less than 48 inches (1219 mm) minimum in width.

306.7.6.1 Ramps. Where steeper slopes than allowed by Section 1012.2 of the *International Building Code* are necessitated by space limitations, the slope of ramps in or providing access to existing facilities shall comply with Table 306.7.6.1.

**Table 306.7.6.1**

**RAMPS**

| SLOPE                                       | MAXIMUM RISE |
|---|--------------|
| Steeper than 1:10 but not steeper than 1:8  | 3 inches     |
| Steeper than 1:12 but not steeper than 1:10 | 6 inches     |

For SI: 1 inch = 25.4 mm.

306.7.7 Elevators. Altered elements of existing elevators shall comply with ASME A17.1. Such elements shall also be altered in elevators programmed to respond to the same hall call control as the altered elevator.

306.7.8 Platform lifts. Platform (wheelchair) lifts installed in accordance with ASME A18.1 shall be permitted as a component of an accessible route.

306.7.8.1 Inclined stairway chairlifts. Inclined stairway chairlifts that do not reduce the required means of egress and installed in accordance with ASME A18.1 shall be permitted as a component of an accessible route in alterations of existing occupancies in:

1. Religious organizations or entities controlled by religious organizations, including places of worship; or
2. Private clubs or establishments exempted under Title II of the Civil Rights Act of 1964.

Such inclined stairway chairlifts shall be approved for commercial use by the manufacturer and installed by approved factory trained installers.

**306.7.9 Stairways and escalators in existing buildings.** Where an escalator or stairway is added where none existed previously and major structural modifications are necessary for installation, an accessible route complying with Section 1104.4 of the *International Building Code* is required between levels served by such escalator or stairway. \_\_\_\_\_

**306.7.10 Determination of number of units.** Where Chapter 11 of the *International Building Code* requires Accessible, Type A or Type B units and where such units are being altered or added, the number of Accessible, Type A and Type B units shall be determined in accordance with Sections 306.7.10.1 through 306.7.10.3.

**306.7.10.1 Accessible dwelling or sleeping units.** Where Group I-1, I-2, I-3, R-1, R-2 or R-4 dwelling or sleeping units are being altered or added, the requirements of Section 1108 of the *International Building Code* for Accessible units apply only to the quantity of spaces being altered or added.

**306.7.10.2 Type A dwelling or sleeping units.** Where more than 20 Group R-2 dwelling or sleeping units are being altered or added, the requirements of Section 1108 of the *International Building Code* for Type A units apply only to the quantity of the spaces being altered or added.

**306.7.10.3 Type B dwelling or sleeping units.** Where four or more Group I-1, I-2, R-1, R-2, R-3 or R-4 dwelling or sleeping units are being added, the requirements of Section 1108 of the *International Building Code* for Type B units apply only to the quantity of the spaces being added. Where Group I-1, I-2, R-1, R-2, R-3 or R-4 dwelling or sleeping units are being altered and where the *work area* is greater than 50 percent of the aggregate area of the building, the requirements of Section 1108 of the *International Building Code* for Type B units apply only to the quantity of the spaces being altered.

**306.7.11 Toilet rooms.** Where it is *technically infeasible* to alter existing toilet rooms to be accessible, one accessible single-user toilet room or one accessible family or assisted-use toilet room constructed in accordance with Section 1110.2.1 of the *International Building Code* is permitted. This toilet room shall be located on the same floor and in the same area as the existing toilet rooms. At the inaccessible toilet rooms, directional signs indicating the location of the nearest such toilet room shall be provided. These directional signs shall include the International Symbol of Accessibility, and sign characters shall meet the visual character requirements in accordance with ICC A117.1.

**306.7.12 Bathing rooms.** Where it is *technically infeasible* to alter existing bathing rooms to be accessible, one accessible single-user bathing room or one accessible family or assisted-use bathing room constructed in accordance with Section 1110.2.1 of the *International Building Code* is permitted. This accessible bathing room shall be located on the same floor and in the same area as the existing bathing rooms. At the inaccessible bathing rooms, directional signs indicating the location of the nearest such bathing room shall be provided. These directional signs shall include the International Symbol of Accessibility, and sign characters shall meet the visual character requirements in accordance with ICC A117.1.

306.7.13 **Additional toilet and bathing facilities.** In assembly and mercantile occupancies, where additional toilet fixtures are added, not fewer than one accessible family or assisted-use toilet room shall be provided where required by Section 1110.2.1 of the *International Building Code*. In recreational *facilities*, where additional bathing rooms are being added, not fewer than one family or assisted-use bathing room shall be provided where required by Section 1110.2.1 of the *International Building Code*.

306.7.14 **Dressing, fitting and locker rooms.** Where it is *technically infeasible* to provide accessible dressing, fitting or locker rooms at the same location as similar types of rooms, one accessible room on the same level shall be provided. Where separate-sex *facilities* are provided, accessible rooms for each sex shall be provided. Separate-sex *facilities* are not required where only unisex rooms are provided.

306.7.15 **Amusement rides.**

306.7.16 **Historic** structures. Where compliance with the requirements for accessible routes, entrances or toilet rooms would threaten or destroy the historic significance of the historic structure, as determined by the authority having jurisdiction, the alternative requirements of Sections 306.7.16.1 through 306.7.16.5 for that element shall be permitted.

Exceptions:

1. Accessible means of egress required by Chapter 10 of the *International Building Code* are not required to be provided in historic structures.
2. The altered element or space is not required to be on an accessible route, unless required by Sections 306.7.16.1 or 306.7.16.2.

306.7.16.1 **Site arrival points.** Not fewer than one exterior accessible route, including curb ramps from a site arrival point to an accessible entrance, shall be provided and shall not be less than 48 inches (219 mm) minimum in width.

306.7.16.2 **Multiple-level buildings and facilities.** An accessible route from an accessible entrance to public spaces on the level of the accessible entrance shall be provided.

306.7.16.3 **Entrances.** Where an entrance cannot be made accessible in accordance with Section 306.7.5, an accessible entrance that is unlocked while the building is occupied shall be provided; or, a locked accessible entrance with a notification system or remote monitoring shall be provided.

Signs complying with Section 1112 of the *International Building Code* shall be provided at the public entrances and the accessible entrance.

306.7.16.4 **Toilet** facilities. Where toilet rooms are provided, not fewer than one accessible single-user toilet room or one accessible family or assisted-use toilet room complying with Section 1110.2.1 of the *International Building Code* shall be provided.

306.7.16.5 Bathing facilities. Where bathing rooms are provided, not fewer than one accessible single-user bathing room or one accessible family or assisted-use bathing rooms complying with Section 1110.2.1 of the *International Building Code* shall be provided.

306.7.16.6 Type A units. The *alteration* to Type A individually owned dwelling units within a Group R-2 occupancy shall be permitted to meet the provision for a Type B dwelling unit.

306.7.16.7 Type B units. Type B dwelling or sleeping units required by Section 1108 of the *International Building Code* are not required to be provided in *historic buildings*.

306.7.17 Thresholds. The maximum height of thresholds at doorways shall be  $\frac{3}{4}$  inch (19.1 mm). Such thresholds shall have beveled edges on each side.

## SECTION 307 \*\* FIRE PROTECTION

307.1 Fire alarm and detection. Fire alarms and detection systems shall be installed in accordance with Sections 307.2 and 307.3.

307.2 Fire alarms. Work areas that do not have an existing fire alarm system are not required to install a fire alarm system. Work areas where new fire alarm systems are installed shall be in accordance with Section 907 of the *North Carolina Building Code*. Smoke alarms for Group R occupancy are permitted to be radio frequency type appliances as allowed and installed by NFPA 72.

Exception: Interconnection of smoke alarms outside of the work area shall not be required.

307.3 Smoke alarms. Individual sleeping units and individual dwelling units in any work area in Group R and I-1 occupancies shall be provided with smoke alarms in accordance with Section 907.2.11 of the *North Carolina Building Code*. Smoke alarms for Group R occupancy are permitted to be radio frequency type appliances as allowed and installed by NFPA 72.

Exception: Interconnection of smoke alarms outside of the work area shall not be required.



**307.3.1 Smoke detection Group R mixed use.** Any nonresidential occupancy work area located directly below Group R shall be provided with single- or multiple-station smoke detectors complying with NFPA 72 and shall provide an audible alarm in each dwelling unit located on floors above the nonresidential work area. The detectors shall be AC powered with battery backup.

**Exceptions:**

1. Hardwired, interconnected smoke detectors installed throughout the building shall be accepted as complying with this section.
2. The work area of the nonresidential occupancy is less than 50 percent of the gross floor area of the nonresidential occupancy.

**307.3.2 Smoke alarms in one- and two-family dwellings and townhouses.** Detached one- and two-family dwellings and townhouses shall be provided with smoke alarms installed in accordance with Section R314 of the *North Carolina Residential Code*.

**\*\* SECTION 308**

**CARBON MONOXIDE ALARMS AND DETECTION**

**308.1 Carbon monoxide alarms.** Individual sleeping units and individual dwelling units in Group R and I occupancies

and classrooms in Group E occupancies and Group A-2 occupancies that contain a fuel-burning appliance or a fuel-burning fireplace shall be provided with carbon monoxide alarms in accordance with Section 915 of the *North Carolina Building Code*, except that the carbon monoxide alarms shall be allowed to be solely battery operated.

**308.2 Carbon monoxide alarms in one- and two-family dwellings and townhouses.** Detached one- and two-family dwellings and townhouses shall be provided with carbon monoxide alarms installed in accordance with Section R315 of the *North Carolina Residential Code*.

**SECTION 309**

**ADDITIONS AND REPLACEMENTS OF EXTERIOR WALL COVERINGS AND EXTERIOR WALL ENVELOPES**

309.1 General. The provisions of Section 309 apply to all *alterations, repairs, additions, relocations of structures and changes of occupancy* regardless of compliance method.

309.2 Additions and replacements. Where an exterior wall covering or exterior wall envelope is added or replaced, the materials and methods used shall comply with the requirements for new construction in Chapter 14 and Chapter 26 of the International Building Code if the added or replaced exterior wall covering or exterior wall envelope involves two or more contiguous stories and comprises more than 15 percent of the total wall area on any side of the building.

#### SECTION 310

#### FIRE DISTRICT

310.1 General. The provisions of Section 310 shall comply with the International Building Code.

#### SECTION 311

#### TEMPORARY OVERFLOW EMERGENCY SHELTERS FOR THE HOMELESS

311.1 General. Existing A-2 and A-3 occupancies shall be permitted to provide facilities for temporary overflow emergency

shelters for the homeless provided that all of the following conditions are met and approved by the local code official and fire marshal.

311.1.1 Occupant load and age. The total number of homeless occupants is limited to 20 individuals who are ambulatory. The homeless occupants must be 18 years of age or older.

Exception: Occupants may be less than 18 years of age if the temporary shelter meets all of the following conditions:

1. Is intended to serve homeless families with children and their parents or other legal guardian;
2. Consists of a group of churches or other nonprofit religious entities that have agreed to host the shelter occupants on the premises of each church or religious entity on a rotating basis; and
3. Equipped with smoke detectors meeting applicable code provisions for such devices in all sleeping areas.

311.1.2 Construction type. The building must be of Type I, II, or III construction.

311.1.3 Staff. The temporary overflow emergency shelter must be staffed by a minimum of two individuals of 21 years of age or older trained in accordance with Chapter 4 of the North Carolina Fire Code and at least one trained individual shall be awake to monitor the sleeping room and restrooms throughout the time the facility is occupied by the homeless.

**311.1.4 Fire alarm and detection systems.** Functioning smoke detection and a local fire alarm system in accordance with Section 907.2.8 of the *North Carolina Building Code* shall be provided throughout the sleeping room and exit access corridors and stairs of the temporary overflow emergency shelter. The building owner shall submit documentation illustrating that the fire alarm system is approved and that all emergency batteries have been tested and are operational.

**311.1.5 Means of egress.** There shall be a minimum of two separate code compliant means of egress serving the temporary overflow emergency shelter. An evacuation route approved by the local building and fire code officials shall be posted and be in compliance with Sections 404, 406, and 408 of the *North Carolina Fire Code*.

**311.1.5.1 Illumination.** The temporary overflow emergency shelter sleeping room and exit access corridors and stairs shall have unswitched illumination and emergency powered illumination with a duration of not less than 90 minutes.

**311.1.6 Automatic sprinkler system.** No fire protection sprinkler system is required by Section 903.2.8, Exception 2 of the *North Carolina Building Code*.

**311.1.7 Ventilation and temperature control.** Heating, cooling, and ventilation must be provided by equipment installed and approved for such use. Use of space heaters shall be prohibited.

**311.1.8 Fire extinguishers.** There must be an adequate number of fire extinguishers to serve the temporary overflow emergency shelter as determined by the local fire marshal. Travel distance to an approved fire extinguisher shall not exceed 50 feet (15 240 mm). Minimum rating of extinguishers shall be 3A40BC.

**311.1.9 Occupant restrictions.** No smoking is permitted in the temporary overflow emergency shelter.

**311.1.10 Permits.** Temporary overflow emergency shelters must be approved by the local code official for occupancy by issuance of an approved occupancy permit. Drawings of the temporary overflow emergency shelter sealed by a *registered design professional* must be provided for local code official review and approval. Occupancy of a temporary overflow emergency shelter shall be for a maximum of 150 calendar days within any 365 day time span.

**311.1.11 Accessibility.** For temporary overflow emergency shelters, compliance with Chapter 11 and Section 1007 of the *North Carolina Building Code* is not required provided that the local jurisdiction has other shelter facilities that are accessible by the disabled.

## **CHAPTER 4**

# **PRESCRIPTIVE COMPLIANCE METHOD**

### **SECTION 401**

#### **GENERAL**

#### **401.1 Scope.**

The provisions of this chapter shall control the *alteration, repair, addition and change of occupancy* or relocation of *existing buildings* and structures, including *historic buildings* and structures as referenced in Section 301.1.1.

**Exception:** Existing bleachers, grandstands and folding and telescopic seating shall comply with ICC 300.

#### **401.1.1 Compliance with other methods.**

*Alterations, repairs, additions and changes of occupancy* to or relocation of, *existing buildings* and structures shall comply with the provisions of this chapter or with one of the methods provided in Section 301.1.

#### **401.2 Building materials and systems.**

Building materials and systems shall comply with the requirements of this section.

#### **401.2.1 Existing materials.**

Materials already in use in a building in compliance with requirements or approvals in effect at the time of their erection or installation shall be permitted to remain in use unless determined by the building official to be unsafe per the *North Carolina Administrative Code and Policies*.

#### ~~401.2.2 New and replacement materials.~~

~~Except as otherwise required or permitted by this code, materials permitted by the applicable code for new construction shall be used. Like materials shall be permitted for *repairs* and *alterations*, provided no hazard to life, health or property is created. Hazardous materials shall not be used where the code for new construction would not permit their use in buildings of similar occupancy, purpose and location.~~

#### ~~401.2.3 Existing seismic force-resisting systems.~~

~~Where the existing seismic force-resisting system is a type that can be designated ordinary, values of  $R$ ,  $\Omega_0$  and  $C_e$  for the existing seismic force-resisting system shall be those specified by the *International Building Code* for an ordinary system unless it is demonstrated that the existing system will provide performance equivalent to that of a detailed, intermediate or special system.~~

#### ~~401.3 Dangerous conditions.~~

~~The building official shall have the authority to require the elimination of conditions deemed *dangerous*.~~

## SECTION 402

### ADDITIONS

#### ~~402.1 General.~~

~~*Additions* to any building or structure shall comply with the requirements of the *International Building Code* for new construction. Alterations to the *existing building* or structure shall be made to ensure that the *existing building* or structure together with the *addition* are no less conforming to the provisions of the *International Building Code* than the *existing building* or structure was prior to the *addition*. An *existing building* together with its *additions* shall comply with the height and area provisions of Chapter 5 of the *International Building Code*.~~

#### ~~[BS] 402.2 Flood hazard areas.~~

~~For buildings and structures in *flood hazard* areas established in Section 1612.3 of the *International Building Code*, or Section R322 of the *International Residential Code*, as applicable, any *addition* that constitutes *substantial improvement* of the existing structure shall comply with the flood design requirements for new construction, and all aspects of the existing structure shall be brought into compliance with the requirements for new construction for flood design.~~

For buildings and structures in *flood hazard areas* established in Section 1612.3 of the *International Building Code*, or Section R322 of the *International Residential Code*, as applicable, any *additions* that do not constitute *substantial improvement* of the existing structure are not required to comply with the flood design requirements for new construction.

### **[BS] 402.3 Existing structural elements carrying gravity load.**

Any existing gravity load-carrying structural element for which an *addition* and its related alterations cause an increase in design gravity load of more than ~~5~~ 10 percent shall be strengthened, supplemented, replaced or otherwise altered as needed to carry the increased gravity load required by the *International Building Code* for new structures. Any existing gravity load-carrying structural element whose gravity load-carrying capacity is decreased shall be considered an altered element subject to the requirements of Section 403.3. Any existing element that will form part of the lateral load path for any part of the *addition* shall be considered an existing lateral load-carrying structural element subject to the requirements of Section 402.4.

#### **[BS] 402.3.1 Design live load.**

Where the *addition* does not result in increased design live load, existing gravity load-carrying structural elements shall be permitted to be evaluated and designed for live loads approved prior to the *addition*. If the approved live load is less than that required by Section 1607 of the *International Building Code*, the area designed for the nonconforming live load shall be posted with placards of approved design indicating the approved live load. Where the *addition* does result in increased design live load, the live load required by Section 1607 of the *International Building Code* shall be used.

### **[BS] 402.4 Existing structural elements carrying lateral load.**

Where the *addition* is structurally independent of the existing structure, existing lateral load-carrying structural elements shall be permitted to remain unaltered. Where the *addition* is not structurally independent of the existing structure, the existing structure and its *addition* acting together as a single structure shall be shown to meet the requirements of Sections 1609 and 1613 of the *International Building Code*. For purposes of this section, compliance with ASCE 41, using a Tier 3 procedure and the two-level performance objective in Table 301.1.4.1 for the applicable risk category, shall be deemed to meet the requirements of Section 1613.

**Exception:** Any existing lateral load-carrying structural element whose demand-capacity ratio with the *addition* considered is no more than 10 percent greater than its demand-capacity ratio with the *addition* ignored shall be permitted to remain unaltered. For purposes of calculating demand-capacity ratios, the demand shall consider applicable load combinations with design lateral loads or forces in accordance with Sections 1609 and 1613 of the 2018 2024 North Carolina Existing Building Code

~~*International Building Code.* For purposes of this exception, comparisons of demand capacity ratios and calculation of design lateral loads, forces and capacities shall account for the cumulative effects of *additions* and *alterations* since original construction.~~

#### **~~402.5 Smoke alarms in existing portions of a building.~~**

~~Where an *addition* is made to a building or structure of a Group R or I-1 occupancy, the *existing building* shall be provided with smoke alarms in accordance with Section 907.2.11 of the *North Carolina Building Code*. Smoke alarms for Group R occupancies are permitted to be radio frequency type appliances as allowed and installed by NFPA 72.~~

##### **~~402.5.1 Smoke alarms in existing portions of one- and two-family dwellings and townhouses.~~**

~~Where an *addition* is made to a detached one- and two-family dwelling or townhouse, the *existing building* shall be provided with smoke alarms installed in accordance with Section R314 of the *North Carolina Residential Code*.~~

#### **~~402.6 Carbon monoxide alarms in existing portions of a building.~~**

~~Where an *addition* is made to a building or structure of a Group I-1, I-2, I-4 or R occupancies, or classrooms are added in Group E occupancies, the *existing building* shall be provided with carbon monoxide alarms in accordance with Section 915 of the *North Carolina Building Code*, except that the carbon monoxide alarms shall be allowed to be solely battery operated.~~

##### **~~402.6.1 Carbon monoxide alarms in existing portions of one- and two-family dwellings and townhouses.~~**

~~Where an *addition* is made to a detached one- and two-family dwelling or townhouse, the *existing building* shall be provided with carbon monoxide alarms installed in accordance with Section R315 of the *North Carolina Residential Code*.~~

## **SECTION 403 ALTERATIONS**

#### **403.1 General.**

Except as provided by Section 401.2 or this section, ~~alterations~~ to any building or structure shall comply with the requirements of the ~~International Building Code~~ for new construction. ~~Alterations~~ shall be such that the ~~existing building~~ or structure is no less conforming to the provisions of the ~~International Building Code~~ than the ~~existing building~~ or structure was prior to the ~~alteration~~.

#### **Exceptions:**

- ~~1. An existing stairway shall not be required to comply with the requirements of Section 1011 of the International Building Code where the existing space and construction does not allow a reduction in pitch or slope.~~
- ~~2. Handrails otherwise required to comply with Section 1011.11 of the International Building Code shall not be required to comply with the requirements of Section 1014.6 of the International Building Code regarding full extension of the handrails where such extensions would be hazardous due to plan configuration.~~

#### **[BS] 403.2 Flood hazard areas.**

~~For buildings and structures in flood hazard areas established in Section 1612.3 of the International Building Code, or Section R322 of the International Residential Code, as applicable, any alteration that constitutes substantial improvement of the existing structure shall comply with the flood design requirements for new construction, and all aspects of the existing structure shall be brought into compliance with the requirements for new construction for flood design.~~

~~For buildings and structures in flood hazard areas established in Section 1612.3 of the International Building Code, or Section R322 of the International Residential Code, as applicable, any alterations that do not constitute substantial improvement of the existing structure are not required to comply with the flood design requirements for new construction.~~

#### **[BS] 403.3 Existing structural elements carrying gravity load.**

~~Any existing gravity load carrying structural element for which an alteration causes an increase in design gravity load of more than 5 10 percent shall be strengthened, supplemented, replaced or otherwise altered as needed~~



to carry the increased gravity load required by the *International Building Code* for new structures. Any existing gravity load-carrying structural element whose gravity load-carrying capacity is decreased as part of the *alteration* shall be shown to have the capacity to resist the applicable design gravity loads required by the *International Building Code* for new structures.

**[BS] 403.3.1 Design live load.**

Where the *alteration* does not result in increased design live load, existing gravity load-carrying structural elements shall be permitted to be evaluated and designed for live loads approved prior to the *alteration*. If the approved live load is less than that required by Section 1607 of the *International Building Code*, the area designed for the nonconforming live load shall be posted with placards of approved design indicating the approved live load. Where the *alteration* does result in increased design live load, the live load required by Section 1607 of the *International Building Code* shall be used.

**[BS] 403.4 Existing structural elements carrying lateral load.**

Except as permitted by Section 403.5, where the *alteration* increases design lateral loads in accordance with Section 1609 or 1613 of the *International Building Code*, or where the *alteration* results in a prohibited structural irregularity as defined in ASCE 7, or where the *alteration* decreases the capacity of any existing lateral load-carrying structural element, the structure of the altered building or structure shall be shown to meet the requirements of Sections 1609 and 1613 of the *International Building Code*. For purposes of this section, compliance with ASCE 41, using a Tier 3 procedure and the two-level performance objective in Table 301.1.4.1 for the applicable risk category, shall be deemed to meet the requirements of Section 1613 of the *International Building Code*.

**Exception:** Any existing lateral load-carrying structural element whose demand-capacity ratio with the *alteration* considered is no more than 10 percent greater than its demand-capacity ratio with the *alteration* ignored shall be permitted to remain unaltered. For purposes of calculating demand-capacity ratios, the demand shall consider applicable load combinations with design lateral loads or forces in accordance with Sections 1609 and 1613 of the *International Building Code*. For purposes of this exception, comparisons of demand-capacity ratios and calculation of design lateral loads, forces and capacities shall account for the cumulative effects of *additions* and *alterations* since original construction.

**[BS] 403.4.1 Seismic Design Category F. Deleted.**

~~[BS] 403.5 Bracing for unreinforced masonry parapets upon reroofing. Deleted.~~

~~[BS] 403.6 Wall anchorage for unreinforced masonry walls in major alterations. Deleted.~~

~~[BS] 403.7 Bracing for unreinforced masonry parapets in major alterations. Deleted.~~

~~[BS] 403.8 Roof diaphragms resisting wind loads in high wind regions. Deleted.~~

**~~[BS] 403.9 Voluntary seismic improvements.~~**

~~Alterations to existing structural elements or additions of new structural elements that are not otherwise required by this chapter and are initiated for the purpose of improving the performance of the seismic force-resisting system of an existing structure or the performance of seismic bracing or anchorage of existing nonstructural elements shall be permitted, provided that an engineering analysis is submitted demonstrating the following:~~

- ~~1. The altered structure and the altered nonstructural elements are no less conforming to the provisions of the *International Building Code* with respect to earthquake design than they were prior to the *alteration*.~~
- ~~2. New structural elements are detailed as required for new construction.~~
- ~~3. New or relocated nonstructural elements are detailed and connected to existing or new structural elements as required for new construction.~~
- ~~4. The *alterations* do not create a structural irregularity as defined in ASCE 7 or make an existing structural irregularity more severe.~~

**~~403.10 Smoke alarms.~~**

~~Individual sleeping units and individual dwelling units in Group R and I-1 occupancies shall be provided with~~

~~smoke alarms in accordance with Section 907.2.11 of the *North Carolina Building Code*. Smoke alarms for Group R occupancies are permitted to be radio frequency type appliances as allowed and installed by NFPA 72.~~

~~**403.10.1 Smoke alarms in one- and two-family dwellings and townhouses.**~~

~~Detached one- and two-family dwellings and townhouses shall be provided with smoke alarms installed in accordance with Section R314 of the *North Carolina Residential Code*.~~

~~**403.11 Carbon monoxide alarms.**~~

~~Individual sleeping units and individual dwelling units in Group R and I occupancies and classrooms in Group E occupancies shall be provided with carbon monoxide alarms in accordance with Section 915 of the *North Carolina Building Code*, except that the carbon monoxide alarms shall be allowed to be solely battery operated.~~

~~**403.11.1 Carbon monoxide alarms in one- and two-family dwellings and townhouses.**~~

~~Detached one- and two-family dwellings and townhouses shall be provided with carbon monoxide alarms installed in accordance with Section R315 of the *North Carolina Residential Code*.~~

~~**403.112 Refuge areas.**~~

~~Where alterations affect the configuration of an area utilized as a refuge area, the capacity of the refuge area shall not be reduced below that required in Sections 403.11.1 through 403.11.3.~~

~~**403.112.1 Smoke compartments.**~~

~~In Group I-2 and I-3 occupancies, the required capacity of the refuge areas for smoke compartments in accordance with Sections 407.5.1 and 408.6.2 of the *International Building Code* shall be maintained.~~

~~**403.112.2 Ambulatory care.**~~

~~In ambulatory care facilities required to be separated by Section 422.2 of the *International Building Code*, the required capacity of the refuge areas for smoke compartments in accordance with Section 422.4 of the *International Building Code* shall be maintained.~~

~~**403.112.3 Horizontal exits.**~~

~~The required capacity of the refuge area for horizontal exits in accordance with Section 1026.4 of the *International Building Code* shall be maintained.~~

## SECTION 404 REPAIRS

### **404.1 General.**

~~Buildings and structures, and parts thereof, shall be repaired in compliance with Sections 401.2 and 404. Work on nondamaged components that is necessary for the required *repair* of damaged components shall be considered part of the *repair* and shall not be subject to the requirements for *alterations* in this chapter. Routine maintenance required by Section 401.2, ordinary repairs exempt from permit in accordance with North Carolina general statute, and abatement of wear due to normal service conditions shall not be subject to the requirements for repairs in this section.~~

### **[BS] 404.2 Substantial structural damage to vertical elements of the lateral force-resisting system.**

~~A building that has sustained *substantial structural damage* to the vertical elements of its lateral force-resisting system shall be evaluated and repaired in accordance with the applicable provisions of Sections 404.2.1 through 404.2.3.~~

#### **Exceptions:**

- ~~1. Buildings assigned to Seismic Design Category A, B or C whose substantial structural damage was not caused by earthquake need not be evaluated or rehabilitated for load combinations that include earthquake effects.~~
  
- ~~2. Other than townhouses, structures regulated by the *North Carolina Residential Code* need not be evaluated or rehabilitated for load combinations that include earthquake effects.~~

### **[BS] 404.2.1 Evaluation.**

~~The building shall be evaluated by a *registered design professional*, and the evaluation findings shall be submitted to the *building official*. The evaluation shall establish whether the damaged building, if repaired to its predamage state, would comply with the provisions of the *International Building Code* for wind and earthquake loads.~~

Wind loads for this evaluation shall be those prescribed in Section 1609 of the *International Building Code*. Earthquake loads for this evaluation, if required, shall be permitted to be 75 percent of those prescribed in Section 1613 of the *International Building Code*. Alternatively, compliance with ASCE 41, using the performance objective in Table 301.1.4.2 for the applicable risk category, shall be deemed to meet the earthquake evaluation requirement.

**~~[BS] 404.2.2 Extent of repair for compliant buildings.~~**

~~If the evaluation establishes compliance of the predamage building in accordance with Section 404.2.1, then repairs shall be permitted that restore the building to its predamage state.~~

**~~[BS] 404.2.3 Extent of repair for noncompliant buildings.~~**

~~If the evaluation does not establish compliance of the predamage building in accordance with Section 404.2.1, then the building shall be rehabilitated to comply with applicable provisions of the *International Building Code* for load combinations that include wind or seismic loads. The wind loads for the repair shall be as required by the building code in effect at the time of original construction, unless the damage was caused by wind, in which case the wind loads shall be as required by the *International Building Code*. Earthquake loads for this rehabilitation design shall be those required for the design of the predamage building, but not less than 75 percent of those prescribed in Section 1613 of the *International Building Code*. New structural members and connections required by this rehabilitation design shall comply with the detailing provisions of the *International Building Code* for new buildings of similar structure, purpose and location. Alternatively, compliance with ASCE 41, using the performance objective in Table 301.1.4.2 for the applicable risk category, shall be deemed to meet the earthquake rehabilitation requirement.~~

**~~[BS] 404.3 Substantial structural damage to gravity load carrying components.~~**

~~Gravity load carrying components that have sustained *substantial structural damage* shall be rehabilitated to comply with the applicable provisions of the *International Building Code* for dead and live loads. Snow loads shall be considered if the substantial structural damage was caused by or related to snow load effects. Existing gravity load carrying structural elements shall be permitted to be designed for live loads approved prior to the damage. If the approved live load is less than that required by Section 1607 of the *International Building Code*, the area designed for the nonconforming live load shall be posted with placards of *approved* design indicating the *approved* live load. Nondamaged gravity load carrying components that receive dead, live or snow loads from rehabilitated components shall also be rehabilitated or shown to have the capacity to carry the design loads of the *rehabilitation* design. New structural members and connections required by this rehabilitation design~~

shall comply with the detailing provisions of the *International Building Code* for new buildings of similar structure, purpose and location.

**~~[BS] 404.3.1 Lateral force-resisting elements.~~**

~~Regardless of the level of damage to vertical elements of the lateral force-resisting system, if *substantial structural damage* to gravity load-carrying components was caused primarily by wind or earthquake effects, then the building shall be evaluated in accordance with Section 404.2.1 and, if noncompliant, rehabilitated in accordance with Section 404.2.3.~~

**~~Exceptions:~~**

- ~~1. Other than townhouses, structures regulated by the *North Carolina Residential Code* need not be evaluated or rehabilitated for load combinations that include earthquake effects.~~
- ~~2. Buildings assigned to Seismic Design Category A, B or C whose substantial structural damage was not caused by earthquake need not be evaluated or rehabilitated for load combinations that include earthquake effects.~~

**~~[BS] 404.4 Less than substantial structural damage.~~**

~~For damage less than *substantial structural damage*, repairs shall be allowed that restore the building to its predamage state. New structural members and connections used for this *repair* shall comply with the detailing provisions of the *International Building Code* for new buildings of similar structure, purpose and location.~~

**~~[BS] 404.5 Flood hazard areas.~~**

~~For buildings and structures in *flood hazard areas* established in Section 1612.3 of the *International Building Code*, or Section R322 of the *International Residential Code*, as applicable, any repair that constitutes *substantial improvement* or repair of *substantial damage* of the existing structure shall comply with the flood design requirements for new construction, and all aspects of the existing structure shall be brought into compliance with the requirements for new construction for flood design.~~

~~For buildings and structures in flood hazard areas established in Section 1612.3 of the *International Building Code*, or Section R322 of the *International Residential Code*, as applicable, any repairs that do not constitute~~  
2018 2024 North Carolina Existing Building Code

~~substantial improvement or repair of substantial damage of the existing structure are not required to comply with the flood design requirements for new construction.~~

## **SECTION 405**

### **FIRE ESCAPES**

#### **405.1 Where permitted.**

~~Fire escapes shall be permitted only as provided for in Sections 405.1.1 through 405.1.4.~~

##### **405.1.1 New buildings.** Deleted.

##### **405.1.2 Existing fire escapes.**

~~Existing fire escapes shall continue to be accepted as a component in the means of egress in *existing buildings* only.~~

##### **405.1.3 New fire escapes.**

~~New fire escapes for *existing buildings* shall be permitted only where exterior stairways cannot be utilized due to lot lines limiting stairway size or due to the sidewalks, alleys or roads at grade level. New fire escapes shall not incorporate ladders or access by windows.~~

##### **405.1.4 Limitations.**

~~Fire escapes shall comply with this section and shall not constitute more than 50 percent of the required number of exits nor more than 50 percent of the required exit capacity.~~

#### **405.2 Location.**

~~Where located on the front of the building and where projecting beyond the building line, the lowest landing shall be not less than 7 feet (2134 mm) or more than 12 feet (3658 mm) above grade, and shall be equipped with a counterbalanced stairway to the street. In alleyways and thoroughfares less than 30 feet (9144 mm) wide, the clearance under the lowest landing shall be not less than 12 feet (3658 mm).~~

#### **~~405.3 Construction.~~**

~~The fire escape shall be designed to support a live load of 100 pounds per square foot (4788 Pa) and shall be constructed of steel or other approved *noncombustible materials*. Fire escapes constructed of wood not less than nominal 2 inches (51 mm) thick are permitted on buildings of Type V construction. Walkways and railings located over or supported by combustible roofs in buildings of Type III and IV construction are permitted to be of wood not less than nominal 2 inches (51 mm) thick.~~

#### **~~405.4 Dimensions.~~**

~~Stairways shall be at least 22 inches (559 mm) wide with risers not more than, and treads not less than, 8 inches (203 mm) and landings at the foot of stairways not less than 40 inches (1016 mm) wide by 36 inches (914 mm) long, located not more than 8 inches (203 mm) below the door.~~

#### **~~405.5 Opening protectives.~~**

~~Doors and windows along the fire escape shall be protected with  $\frac{3}{4}$ -hour opening protectives.~~

## **SECTION 406 GLASS REPLACEMENT AND REPLACEMENT WINDOWS**

#### **~~406.1 Replacement glass.~~**

~~The installation or replacement of glass shall be as required for new installations.~~

~~**Exception:** Replacement glazing shall be in compliance with Section R503.1.1.1 and Section C503.1.1 of the *North Carolina Energy Conservation Code*.~~

#### **~~406.2 Replacement window opening control devices.~~**

~~In Group R-2 or R-3 buildings containing dwelling units, window opening control devices complying with ASTM F 2090 shall be installed where an existing window is replaced and where all of the following apply to the replacement window:~~

- ~~1. The window is operable;~~



- ~~2. The window replacement includes replacement of the sash and the frame;~~
- ~~3. The top of the sill of the window opening is at a height less than 36 inches (915 mm) above the finished floor;~~
- ~~4. The window will permit openings that will allow passage of a 4-inch diameter (102 mm) sphere when the window is in its largest opened position; and~~
- ~~5. The vertical distance from the top of the sill of the window opening to the finished grade or other surface below, on the exterior of the building, is greater than 72 inches (1829 mm).~~

~~The window opening control device, after operation to release the control device allowing the window to fully open, shall not reduce the minimum net clear opening area of the window unit to less than the area required by Section 1030.2 of the *International Building Code*.~~

**Exceptions:**

- ~~1. Operable windows where the top of the sill of the window opening is located more than 75 feet (22860 mm) above the finished grade or other surface below, on the exterior of the room, space or building, and that are provided with window fall prevention devices that comply with ASTM F 2006.~~
- ~~2. Operable windows with openings that are provided with window fall prevention devices that comply with ASTM F 2090.~~

**~~406.3 Replacement window emergency escape and rescue openings.~~**

~~Where windows are required to provide *emergency escape* and *rescue openings* in Group R-2 and R-3 occupancies, replacement windows shall be exempt from the requirements of Sections 1030.2, 1030.3 and 1030.5 of the *International Building Code* provided the replacement window meets the following conditions:~~

- ~~1. The replacement window is the manufacturer's largest standard size window that will fit within the existing frame or existing rough opening. The replacement window shall be permitted to be of the same operating style as the existing window or a style that provides for an equal or greater window opening area than the existing window.~~
  
- ~~2. The replacement of the window is not part of a change of occupancy.~~

## **SECTION 407**

### **CHANGE OF OCCUPANCY**

#### **407.1 Conformance.**

~~No change shall be made in the use or occupancy of any building unless such building is made to comply with the requirements of the *International Building Code* for the use or occupancy. Changes in use or occupancy in a building or portion thereof shall be such that the existing building is no less complying with the provisions of this code than the existing building or structure was prior to the change. Subject to the approval of the building official, the use or occupancy of *existing buildings* shall be permitted to be changed and the building is allowed to be occupied for purposes in other groups without conforming to all of the requirements of this code for those groups, provided the new or proposed use is less hazardous, based on life and fire risk, than the existing use.~~

~~**Exception:** The building need not be made to comply with the seismic requirements for a new structure unless required by Section 407.4.~~

#### **407.1.1 Change in the character of use.**

~~A change in occupancy with no change of occupancy classification shall not be made to any structure that will subject the structure to any special provisions of the applicable *International Codes*, without approval of the *building official*. Compliance shall be only as necessary to meet the specific provisions and is not intended to require the entire building be brought into compliance.~~

#### **407.2 Certificate of occupancy.**

~~A certificate of occupancy shall be issued where it has been determined that the requirements for the new occupancy classification have been met.~~

### **407.3 Stairways.**

An existing stairway shall not be required to comply with the requirements of Section 1011 of the *International Building Code* where the existing space and construction does not allow a reduction in pitch or slope.

### **[BS] 407.4 Structural.**

When a *change of occupancy* results in a structure being reclassified to a higher risk category from Table 1604.5 of the *North Carolina Building Code*, the structure shall conform to the seismic requirements for a new structure of the higher risk category. For purposes of this section, compliance with ASCE 41, using a Tier 3 procedure and the two-level performance objective in Table 301.1.4.1 for the applicable risk category, shall be deemed to meet the requirements of Section 1613 of the *International Building Code*.

#### **Exceptions:**

1. Specific seismic detailing requirements of Section 1613 of the *International Building Code* for a new structure shall not be required to be met where the seismic performance is shown to be equivalent to that of a new structure. A demonstration of equivalence shall consider the regularity, overstrength, redundancy and ductility of the structure.
2. When a change of use results in a structure being reclassified from Risk Category I or II to Risk Category III and the structure is located where the seismic coefficient, SDS, is less than 0.33, compliance with the seismic requirements of Section 1613 of the *International Building Code* is not required.

### **407.5 Energy conservation.**

Spaces undergoing a change of occupancy shall comply with Sections R505 and C505 of the *North Carolina Energy Conservation Code*.

## **SECTION 408 HISTORIC BUILDINGS**

#### **408.1 Historic buildings.**

~~The provisions of this code that require improvements relative to a building's existing condition or, in the case of repairs, that require improvements relative to a building's predamage condition, shall not be mandatory for historic buildings unless specifically required by this section.~~

#### **408.2 Life safety hazards.**

~~The provisions of this code shall apply to historic buildings judged by the building official to constitute a distinct life safety hazard.~~

#### **[BS] 408.3 Flood hazard areas.**

~~Within flood *hazard areas* established in accordance with Section 1612.3 of the *International Building Code*, or Section R322 of the *International Residential Code*, as applicable, where the work proposed constitutes *substantial improvement*, the building shall be brought into compliance with Section 1612 of the *International Building Code*, or Section R322 of the *International Residential Code*, as applicable:~~

~~**Exception:** *Historic buildings* need not be brought into compliance that are:~~

- ~~1. Listed or preliminarily determined to be eligible for listing in the National Register of Historic Places;~~
- ~~2. Determined by the Secretary of the U.S. Department of Interior as contributing to the historical significance of a registered historic district or a district preliminarily determined to qualify as an historic district; or~~
- ~~3. Designated as historic under a state or local historic preservation program that is approved by the Department of Interior.~~

## **SECTION 409 MOVED STRUCTURES**

#### **409.1 Conformance.**

Structures moved into or within the jurisdiction shall comply with the provisions of this code for new structures.

## **SECTION 410 ACCESSIBILITY FOR EXISTING BUILDINGS**

#### **410.1 Scope.**

The provisions of Sections 410.1 through 410.9 apply to maintenance, *change of occupancy*, *additions* and *alterations* to *existing buildings*, including those identified as *historic buildings*.

#### **410.2 Maintenance of facilities.**

A *facility* that is constructed or altered to be *accessible* shall be maintained *accessible* during occupancy.

#### **410.3 Extent of application.**

An *alteration* of an existing *facility* shall not impose a requirement for greater accessibility than that which would be required for new construction. *Alterations* shall not reduce or have the effect of reducing accessibility of a *facility* or portion of a *facility*.

#### **410.4 Change of occupancy.**

*Existing buildings* that undergo a change of group or occupancy shall comply with this section.

**Exception:** Type B dwelling or sleeping units required by Section 1107 of the *International Building Code* are not required to be provided in *existing buildings* and facilities undergoing a *change of occupancy* in conjunction with *alterations* where the *work area* is 50 percent or less of the aggregate area of the building.

##### **410.4.1 Partial change in occupancy.**

Where a portion of the building is changed to a new occupancy classification, any *alterations* shall comply with Sections 410.6, 410.7 and 410.8.

#### **410.4.2 Complete change of occupancy.**

Where an entire building undergoes a *change of occupancy*, it shall comply with Section 410.4.1 and shall have all of the following accessible features:

1. ~~At least one accessible building entrance.~~
2. ~~At least one accessible route from an accessible building entrance to *primary function* areas.~~
3. ~~Signage complying with Section 1111 of the *International Building Code*.~~
4. ~~Accessible parking, where parking is being provided.~~
5. ~~At least one accessible passenger loading zone, when loading zones are provided.~~
6. ~~At least one accessible route connecting accessible parking and accessible passenger loading zones to an accessible entrance.~~

Where it is *technically infeasible* to comply with the new construction standards for any of these requirements for a change of group or occupancy, the above items shall conform to the requirements to the maximum extent technically feasible.

**Exception:** The accessible features listed in Items 1 through 6 are not required for an accessible route to Type B units.

#### **410.5 Additions.**

Provisions for new construction shall apply to *additions*. An *addition* that affects the accessibility to, or contains an area of, a *primary function* shall comply with the requirements in Section 410.7.

#### **410.6 Alterations.**

A *facility* that is altered shall comply with the applicable provisions in Chapter 11 of the *International Building Code* 2018 2024 North Carolina Existing Building Code

~~Code, unless technically infeasible. Where compliance with this section is technically infeasible, the alteration shall provide access to the maximum extent technically feasible.~~

**Exceptions:**

- ~~1. The altered element or space is not required to be on an accessible route, unless required by Section 410.7.~~
- ~~2. Accessible means of egress required by Chapter 10 of the *International Building Code* are not required to be provided in existing facilities.~~
- ~~3. The alteration to Type A individually owned dwelling units within a Group R-2 occupancy shall be permitted to meet the provision for a Type B dwelling unit.~~
- ~~4. Type B dwelling or sleeping units required by Section 1107 of the *International Building Code* are not required to be provided in existing buildings and facilities undergoing a change of occupancy in conjunction with alterations where the work area is 50 percent or less of the aggregate area of the building.~~

**~~410.7 Alterations affecting an area containing a primary function.~~**

~~Where an alteration affects the accessibility to, or contains an area of primary function, the route to the primary function area shall be accessible. The accessible route to the primary function area shall include toilet facilities and drinking fountains serving the area of primary function.~~

**Exceptions:**

- ~~1. The costs of providing the accessible route are not required to exceed 20 percent of the costs of the alterations affecting the area of primary function.~~

- ~~2. This provision does not apply to *alterations* limited solely to windows, hardware, operating controls, electrical outlets and signs.~~
- ~~3. This provision does not apply to *alterations* limited solely to mechanical systems, electrical systems, installation or *alteration* of fire protection systems and abatement of hazardous materials.~~
- ~~4. This provision does not apply to *alterations* undertaken for the primary purpose of increasing the accessibility of a *facility*.~~
- ~~5. This provision does not apply to altered areas limited to Type B dwelling and sleeping units.~~

#### **~~410.8 Scoping for alterations.~~**

The provisions of Sections ~~410.8.1 through 410.8.14~~ shall apply to ~~*alterations to existing buildings and facilities.*~~

#### **~~410.8.1 Entrances.~~**

~~*Accessible* entrances shall be provided in accordance with Section 1105.~~

~~**Exception:** Where an *alteration* includes alterations to an entrance, and the *facility* has an *accessible* entrance, the altered entrance is not required to be *accessible*, unless required by Section 410.7. Signs complying with Section 1111 of the *International Building Code* shall be provided.~~

#### **~~410.8.2 Elevators.~~**

~~Altered elements of existing elevators shall comply with ASME A17.1 and ICC A117.1. Such elements shall also be altered in elevators programmed to respond to the same hall call control as the altered elevator.~~

#### **~~410.8.3 Platform lifts.~~**

~~Platform (wheelchair) lifts complying with ICC A117.1 and installed in accordance with ASME A18.1 shall be permitted as a component of an accessible route.~~

##### **~~410.8.3.1 Inclined stairway chairlifts.~~**



Inclined stairway chairlifts that do not reduce the required means of egress and installed in accordance with ASME A18.1 shall be permitted as a component of an accessible route in alterations of existing occupancies in:

1. ~~Religious organizations or entities controlled by religious organizations, including places of worship; or~~
2. ~~Private clubs or establishments exempted under Title II of the Civil Rights Act of 1964.~~

Such inclined stairway chairlifts shall be approved for commercial use by the manufacturer and installed by approved factory trained installers.

**410.8.4 Stairways and escalators in existing buildings.**

~~In alterations, change of occupancy or additions where an escalator or stairway is added where none existed previously and major structural modifications are necessary for installation, an accessible route shall be provided between the levels served by the escalator or stairways in accordance with Section 1104.4 of the *International Building Code*.~~

**410.8.5 Ramps.**

~~Where slopes steeper than allowed by Section 1012.2 of the *International Building Code* are necessitated by space limitations, the slope of ramps in or providing access to existing facilities shall comply with Table 410.8.5.~~

**TABLE 410.8.5  
RAMPS**

| SLOPE                                       | MAXIMUM RISE |
|---|--------------|
| Steeper than 1:10 but not steeper than 1:8  | 3 inches     |
| Steeper than 1:12 but not steeper than 1:10 | 6 inches     |

For SI: 1 inch = 25.4 mm.

#### **410.8.6 Accessible dwelling or sleeping units.**

~~Where Group I-1, I-2, I-3, R-1, R-2 or R-4 dwelling or sleeping units are being altered or added, the requirements of Section 1107 of the *International Building Code* for Accessible units apply only to the quantity of spaces being altered or added.~~

#### **410.8.7 Type A dwelling or sleeping units.**

~~Where 11 or more Group R-2 dwelling or sleeping units are being altered or added, the requirements of Section 1107 of the *International Building Code* for Type A units apply only to the quantity of the spaces being altered or added.~~

#### **410.8.8 Type B dwelling or sleeping units.**

~~Where four or more Group I-1, I-2, R-1, R-2, R-3 or R-4 dwelling or sleeping units are being added, the requirements of Section 1107 of the *International Building Code* for Type B units apply only to the quantity of the spaces being added. Where Group I-1, I-2, R-1, R-2, R-3 or R-4 dwelling or sleeping units are being altered and where the work area is greater than 50 percent of the aggregate area of the building, the requirements of Section 1107 of the *International Building Code* for Type B units apply only to the quantity of the spaces being altered.~~

#### **410.8.9 Jury boxes and witness stands.**

~~In *alterations*, accessible wheelchair spaces are not required to be located within the defined area of raised jury boxes or witness stands and shall be permitted to be located outside these spaces where the ramp or lift access restricts or projects into the means of egress.~~

#### **410.8.10 Toilet rooms.**

~~Where it is *technically infeasible* to alter existing toilet and bathing rooms to be *accessible*, an *accessible* family or assisted-use toilet or bathing room constructed in accordance with Section 1109.2.1 of the *International Building Code* is permitted. The family or assisted-use toilet or bathing room shall be located on the same floor and in the same area as the existing toilet or bathing rooms. At the inaccessible toilet and bathing rooms, provide directional signs indicating the location of the nearest family or assisted-use toilet room or bathing room. These directional signs shall include the International Symbol of Accessibility and sign characters shall meet the visual character requirements in accordance with ICC A117.1.~~

#### **410.8.11 Dressing, fitting and locker rooms.**

~~Where it is *technically infeasible* to provide accessible dressing, fitting or locker rooms at the same location~~

~~as similar types of rooms, one accessible room on the same level shall be provided. Where separate sex facilities are provided, accessible rooms for each sex shall be provided. Separate sex facilities are not required where only unisex rooms are provided.~~

#### **410.8.12 Fuel dispensers.**

~~Operable parts of replacement fuel dispensers shall be permitted to be 54 inches (1370 mm) maximum, measuring from the surface of the vehicular way where fuel dispensers are installed on existing curbs.~~

#### **410.8.13 Thresholds.**

~~The maximum height of thresholds at doorways shall be  $\frac{3}{4}$  inch (19.1 mm). Such thresholds shall have beveled edges on each side.~~

#### **410.8.14 Amusement rides.** Deleted.

### **410.9 Historic buildings.**

~~These provisions shall apply to *facilities* designated as historic structures that undergo *alterations* or a *change of occupancy*, unless *technically infeasible*. Where compliance with the requirements for accessible routes, entrances or toilet rooms would threaten or destroy the historic significance of the *facility*, as determined by the applicable governing authority, the alternative requirements of Sections 410.9.1 through 410.9.4 for that element shall be permitted.~~

**Exception:** Type B dwelling or sleeping units required by Section 1107 of the *International Building Code* are not required to be provided in historical buildings.

#### **410.9.1 Site arrival points.**

~~At least one accessible route from a site arrival point to an accessible entrance shall be provided.~~

#### **410.9.2 Multilevel buildings and facilities.**

~~An accessible route from an accessible entrance to public spaces on the level of the accessible entrance shall be provided.~~

### **410.9.3 Entrances.**

At least one main entrance shall be accessible.

#### **Exceptions:**

1. If a main entrance cannot be made accessible, an accessible nonpublic entrance that is unlocked while the building is occupied shall be provided; or
2. If a main entrance cannot be made accessible, a locked accessible entrance with a notification system or remote monitoring shall be provided.

Signs complying with Section 1111 of the *International Building Code* shall be provided at the primary entrance and the accessible entrance.

### **410.9.4 Toilet and bathing facilities.**

Where toilet rooms are provided, at least one accessible family or assisted-use toilet room complying with Section 1109.2.1 of the *International Building Code* shall be provided.

## **SECTION 411**

### **TEMPORARY OVERFLOW EMERGENCY SHELTERS FOR THE HOMELESS**

#### **411.1 General.**

Existing A-2 and A-3 occupancies shall be permitted to provide facilities for temporary overflow emergency shelters for the homeless provided that all of the following conditions are met and approved by the local code official and fire marshal:

##### **411.1.1 Occupant load and age.**

The total number of homeless occupants is limited to 20 individuals who are ambulatory. The homeless occupants must be 18 years of age or older.

#### **411.1.2 Construction Type.**

The building must be of Type I, II, or III construction.

#### **411.1.3 Staff.**

The temporary overflow emergency shelter must be staffed by a minimum of two individuals of 21 years of age or older trained in accordance with Chapter 4 of the *North Carolina Fire Code* and at least one trained individual shall be awake to monitor the sleeping room and restrooms throughout the time the facility is occupied by the homeless.

#### **411.1.4 Fire alarm and detection systems.**

Functioning smoke detection and a local fire alarm system per Section 907.2.8 of the *North Carolina Building Code* shall be provided throughout the sleeping room and exit access corridors and stairs of the temporary overflow emergency shelter.

The building owner shall submit documentation illustrating that the fire alarm system is approved and that all emergency batteries have been tested and are operational.

#### **411.1.5 Means of egress.**

There shall be a minimum of two separate code compliant means of egress serving the temporary overflow emergency shelter. An evacuation route approved by the local building and fire code officials shall be posted and be in compliance with Sections 404, 406, and 408 of the *North Carolina Fire Code*.

##### **411.1.5.1 Illumination.**

The temporary overflow emergency shelter sleeping room and exit access corridors and stairs shall have unswitched illumination and emergency powered illumination with a duration of not less than 90 minutes.

**~~411.1.6 Automatic sprinkler system.~~**

~~No fire protection sprinkler system is required per Section 903.2.8, Exception #2 of the *North Carolina Building Code*.~~

**~~411.1.7 Ventilation and temperature control.~~**

~~Heating, cooling, and ventilation must be provided by equipment installed and approved for such use. Use of space heaters shall be prohibited.~~

**~~411.1.8 Fire extinguishers.~~**

~~There must be an adequate number of fire extinguishers to serve the temporary overflow emergency shelter as determined by the local fire marshal. Travel distance to an approved fire extinguisher shall not exceed 50 feet (15.2 m). Minimum rating of extinguishers shall be 3A40BC.~~

**~~411.1.9 Occupant restrictions.~~**

~~No smoking is permitted in the temporary overflow emergency shelter.~~

**~~411.1.10 Permits.~~**

~~Temporary overflow emergency shelters must be approved by the local code official for occupancy by issuance of an approved occupancy permit. Drawings of the temporary overflow emergency shelter sealed by a *registered design professional* must be provided for local code official review and approval.~~

~~Occupancy of a temporary overflow emergency shelter shall be for a maximum of 150 calendar days within any 365 day time span.~~

**~~411.1.11 Accessibility.~~**

~~For temporary overflow emergency shelters compliance with Chapter 11 and Section 1007 of the *North Carolina Building Code* is not required provided that the local jurisdiction has other shelter facilities that are accessible by the disabled.~~

## **CHAPTER 4**

# **REPAIRS**

### **SECTION 401**

#### **GENERAL**

**401.1 Scope.** *Repairs shall comply with the requirements of this chapter. Repairs to historic buildings need only comply with Chapter 12.*

**401.1.1 Bleachers, grandstands and folding and telescopic seating.** *Repairs to existing bleachers, grandstands and folding and telescopic seating shall comply with ICC 300.*

**401.2 Compliance.** *The work shall not make the building less complying than it was before the repair was undertaken.*

**[BS] 401.3 Flood hazard areas.** *In flood hazard areas, repairs that constitute substantial improvement shall require that the building comply with Section 1612 of the *International Building Code*, or Section R322 of the *International Residential Code*, as applicable.*

### **SECTION 402**

#### **BUILDING ELEMENTS AND MATERIALS**

**402.1 Glazing in hazardous locations.** *Replacement glazing in hazardous locations shall comply with the safety glazing requirements of the *International Building Code* or *International Residential Code* as applicable.*

**Exception:** *Glass block walls, louvered windows and jalousies repaired with like materials.*

**402.2 Wind-borne debris protection.** *Replacement of window units shall require compliance with Section 1609.2 of the *North Carolina Building Code* or Section R609.6 of the *North Carolina Residential Code*. Replacement of individual glass panes or sashes shall not require compliance with Section 1609.2 of the *North Carolina Building Code* and R609.6 of the *North Carolina Residential Code*.*

### **SECTION 403**

#### **FIRE PROTECTION**

**403.1 General.** *Repairs shall be done in a manner that maintains the level of fire protection that exists.*

**SECTION 404**  
**MEANS OF EGRESS**

**404.1 General.** *Repairs shall be done in a manner that maintains the level of protection that exists for the means of egress.*

**SECTION 405**  
**STRUCTURAL**

**[BS] 405.1 General.** Structural *repairs* shall be in compliance with this section and Section 401.2.

**[BS] 405.2 Repairs to damaged buildings.** *Repairs to damaged buildings shall comply with this section.*

**[BS] 405.2.1 Repairs for less than substantial structural damage.** Unless otherwise required by this section, for damage less than *substantial structural damage*, the damaged elements shall be permitted to be restored to their predamage condition.

**[BS] 405.2.1.1 Snow damage.** Structural components whose damage was caused by or related to snow load effects shall be repaired, replaced or altered to satisfy the requirements of Section 1608 of the *International Building Code*.

**[BS] 405.2.2 Disproportionate earthquake damage.** A building assigned to Seismic Design Category D, E or F that has sustained *disproportionate earthquake damage* shall be subject to the requirements for buildings with substantial structural damage to vertical elements of the lateral force-resisting system.

**[BS] 405.2.3 Substantial structural damage to vertical elements of the lateral force-resisting system.** A building that has sustained *substantial structural damage* to the vertical elements of its lateral force-resisting system shall be evaluated in accordance with Section 405.2.3.1, and either repaired in accordance with Section 405.2.3.2 or repaired and retrofitted in accordance with Section 405.2.3.3, depending on the results of the evaluation.

**Exceptions:**

1. Buildings assigned to Seismic Design Category A, B or C whose *substantial structural damage* was not caused by earthquake need not be evaluated or retrofitted for load combinations that include earthquake effects.
2. Detached One- and two-family dwellings need not be evaluated or retrofitted for load combinations that include earthquake effects.

**[BS] 405.2.3.1 Evaluation.** The building shall be evaluated by a registered design professional, and the evaluation findings shall be submitted to the *code official*. The evaluation shall establish whether the damaged building, if repaired to its predamage state, would comply with the provisions of the *International Building Code* for load combinations that include wind or earthquake effects, except that the seismic forces shall be the reduced seismic forces.

**[BS] 405.2.3.2 Extent of repair for compliant buildings.** If the evaluation establishes that the building in its predamage condition complies with the provisions of Section 405.2.3.1, then the damaged elements shall be permitted to be restored to their predamage condition.

**[BS] 405.2.3.3 Extent of repair for noncompliant buildings.** If the evaluation does not establish that the building in its predamage condition complies with the provisions of Section 405.2.3.1, then the building shall be retrofitted to comply with the provisions of this section. The wind loads for the *repair* and *retrofit* shall be those required by the building code in effect at the time of original construction, unless the damage was caused by wind, in which case the wind loads shall



be in accordance with the *International Building Code*. The seismic loads for this *retrofit* design shall be those required by the building code in effect at the time of original construction, but not less than the reduced seismic forces.

**IBS] 405.2.4 Substantial structural damage to gravity load-carrying components.** Gravity load-carrying components that have sustained *substantial structural damage* shall be rehabilitated to comply with the applicable provisions for dead, live and snow loads in the *International Building Code*. Undamaged gravity load-carrying components that receive dead, live or snow loads from rehabilitated components shall also be rehabilitated if required to comply with the design loads of the *rehabilitation* design.

**IBS] 405.2.4.1 Lateral force-resisting elements.** Regardless of the level of damage to vertical elements of the lateral force-resisting system, if *substantial structural damage* to gravity load-carrying components was caused primarily by wind or seismic effects, then the building shall be evaluated in accordance with Section 405.2.3.1 and, if noncompliant, retrofitted in accordance with Section 405.2.3.3.

**Exceptions:**

1. Buildings assigned to Seismic Design Category A, B or C whose *substantial structural damage* was not caused by earthquake need not be evaluated or retrofitted for load combinations that include earthquake effects.
2. Detached One- and two-family dwellings need not be evaluated or retrofitted for load combinations that include earthquake effects.

**IBS] 405.2.5 Substantial structural damage to snow load-carrying components.** Where substantial structural damage to any snow load-carrying components is caused by or related to snow load effects, any components required to carry snow loads on roof framing of similar construction shall be repaired, replaced or retrofitted to satisfy the requirements of Section 1608 of the *International Building Code*.

**IBS] 405.2.6 Flood hazard areas.** In *flood hazard* areas, buildings that have sustained *substantial damage* shall be brought into compliance with Section 1612 of the *International Building Code*, or Section R322 of the *International Residential Code*, as applicable.

## **SECTION 406**

### **ELECTRICAL**

**406.1 Material.** Existing electrical wiring and equipment undergoing *repair* shall be allowed to be repaired or replaced with like material.

**406.1.1 Receptacles.** Replacement of electrical receptacles shall comply with the applicable requirements of Section 406.4(D) of NFPA 70.

**406.1.2 Plug fuses.** Plug fuses of the Edison-base type shall be used for replacements only where there is no evidence of over fusing or tampering per applicable requirements of Section 240.51(B) of NFPA 70.

**406.1.3 Nongrounding-type receptacles.** For replacement of nongrounding-type receptacles with grounding-type receptacles and for branch circuits that do not have an equipment grounding conductor in the branch circuitry, the grounding conductor of a grounding-type receptacle outlet shall be permitted to be grounded to any accessible point on

the grounding electrode system or to any accessible point on the grounding electrode conductor in accordance with Section 250.130(C) of NFPA 70.

**406.1.4 Health care facilities.** Portions of electrical systems being repaired in Group I-2, ambulatory care *facilities* and outpatient clinics shall comply with NFPA 99 requirements for *repairs*.

**406.1.5 Grounding of appliances.** Frames of electric ranges, wall-mounted ovens, counter-mounted cooking units, clothes dryers and outlet or junction boxes that are part of the existing branch circuit for these appliances shall be permitted to be grounded to the grounded circuit conductor in accordance with Section 250.140 of NFPA 70.

## **SECTION 407** **MECHANICAL**

**407.1 General.** Existing mechanical systems undergoing *repair* shall not make the building less complying than it was before the damaged occurred.

**407.2 Mechanical draft systems for manually fired appliances and fireplaces.** A mechanical draft system shall be permitted to be used with manually fired appliances and fireplaces where such a system complies with all of the following requirements:

1. The mechanical draft device shall be listed and installed in accordance with the manufacturer's installation instructions.
2. A device shall be installed that produces visible and audible warning upon failure of the mechanical draft device or loss of electrical power at any time that the mechanical draft device is turned on. This device shall be equipped with a battery backup if it receives power from the building wiring.
3. A smoke detector shall be installed in the room with the appliance or fireplace. This device shall be equipped with a battery backup if it receives power from the building wiring.

## **SECTION 408** **PLUMBING**

**408.1 General.** Existing plumbing systems undergoing *repair* shall not make the building less conforming than it was before the *repair* was undertaken.

**408.12 Materials.** Plumbing materials and supplies shall not be used for *repairs* that are prohibited in the *International Plumbing Code*.

**408.23 Water closet replacement.** The maximum water consumption flow rates and quantities for all replaced water closets shall be 1.6 gallons (6 L) per flushing cycle.

**Exception:** Blowout-design water closets [3.5 gallons (13 L) per flushing cycle].

**408.34 Health care facilities.** Portions of medical gas systems being repaired in Group I-2, ambulatory care *facilities* and outpatient clinics shall comply with NFPA 99 requirements for *repairs*.

**408.5 Water supply system test.** Existing water supply systems that are repaired shall be allowed to be tested and proved tight under a water pressure of normal operating pressure of the existing water supply system. The pressure shall be held at least 15 minutes.

## **SECTION 409**

### **ENERGY CONSERVATION**

**409.1 General.** Repair of building systems shall not make the building less conforming than it was before the repair was undertaken.

**409.2 Materials.** Portions of walls that are part of the building thermal envelope shall be insulated in accordance with the North Carolina Energy Conservation Code when the repair requires the removal of either the interior or exterior wall membrane such that the wall cavity is exposed during the repair.

**Exception:** Wall cavities containing existing insulation material.

**409.3 Glazing.** Repair requiring the replacement of window units shall comply with the requirements of the North Carolina Energy Conservation Code. Repair requiring the replacement of individual glass panes or sashes shall not require compliance with the U-value requirements of the North Carolina Energy Conservation Code.

**Exception:** Historic structures where compliance with the North Carolina Energy Conservation Code would conflict

with the historic nature of the structure are not required to comply with the North Carolina Energy Conservation

Code but shall have an U-value equal to or greater than the exis

# **~~CHAPTER 5~~**

## **~~CLASSIFICATION OF WORK~~**

### **~~SECTION 501~~**

#### **~~GENERAL~~**

##### **~~501.1 Scope.~~**

~~The provisions of this chapter shall be used in conjunction with Chapters 6 through 13 and shall apply to the alteration, repair, addition and change of occupancy of existing structures, including historic and moved~~

~~structures, as referenced in Section 301.1.2. The work performed on an *existing building* shall be classified in accordance with this chapter.~~

**~~501.1.1 Compliance with other alternatives.~~**

~~Alterations, repairs, additions and changes of occupancy to existing structures shall comply with the provisions of Chapters 6 through 13 or with one of the alternatives provided in Section 301.1.~~

**~~501.2 Work area.~~**

~~The *work area*, as defined in Chapter 2, shall be identified on the construction documents.~~

## **SECTION 502**

### **REPAIRS**

**~~502.1 Scope.~~**

~~Repairs, as defined in Chapter 2, include the patching or restoration or replacement of damaged materials, elements, *equipment or fixtures* for the purpose of maintaining such components in good or sound condition with respect to existing loads or performance requirements.~~

**~~502.2 Application.~~**

~~Repairs shall comply with the provisions of Chapter 6.~~

**~~502.3 Related work.~~**

~~Work on nondamaged components that is necessary for the required *repair* of damaged components shall be considered part of the *repair* and shall not be subject to the provisions of Chapter 7, 8, 9, 10 or 11.~~

## **SECTION 503**

### **ALTERATION—LEVEL 1 (Renovation)**

**~~503.1 Scope.~~**

~~Level 1 alterations include the removal and replacement or the covering of existing materials, elements, equipment, or fixtures using new materials, elements, equipment, or fixtures that serve the same purpose.~~

**503.2 Application.**

Level 1 *alterations* shall comply with the provisions of Chapter 7.

**SECTION 504**

**ALTERATION—LEVEL 2 (Alteration)**

**504.1 Scope.**

Level 2 *alterations* include the reconfiguration of space, the addition or elimination of any door or window, the reconfiguration or extension of any system, or the installation of any additional equipment.

**504.2 Application.**

Level 2 *alterations* shall comply with the provisions of Chapter 7 for Level 1 *alterations* as well as the provisions of Chapter 8.

**SECTION 505**

**ALTERATION—LEVEL 3 (Reconstruction)**

**505.1 Scope.**

Level 3 *alterations* apply where the work area exceeds 50 percent of the *building area* in any 12 month time period.

**Exception:** Alterations limited to displays or showrooms in Group M Occupancies.

**505.2 Application.**

Level 3 *alterations* shall comply with the provisions of Chapters 7 and 8 for Level 1 and 2 *alterations*, respectively, as well as the provisions of Chapter 9.

**SECTION 506**

**CHANGE OF OCCUPANCY**

**506.1 Scope.**

~~Change of occupancy provisions apply where the activity is classified as a *change of occupancy* as defined in Chapter 2.~~

**506.2 Application.**

~~Changes of occupancy shall comply with the provisions of Chapter 10.~~

**SECTION 507  
ADDITIONS**

**507.1 Scope.**

~~Provisions for *additions* shall apply where work is classified as an *addition* as defined in Chapter 2.~~

**507.2 Application.**

~~Additions to *existing buildings* shall comply with the provisions of Chapter 11.~~

**SECTION 508  
HISTORIC BUILDINGS**

**508.1 Scope.**

~~*Historic building* provisions shall apply to buildings classified as *historic* as defined in Chapter 2.~~

**508.2 Application.**

~~Except as specifically provided for in Chapter 12, *historic buildings* shall comply with applicable provisions of this code for the type of work being performed.~~

**SECTION 509  
RELOCATED BUILDINGS**

**509.1 Scope.**

~~Relocated building provisions shall apply to relocated or moved buildings.~~

## **~~509.2 Application.~~**

~~Relocated buildings shall comply with the provisions of Chapter 13.~~

# **CHAPTER 5** **PRESCRIPTIVE COMPLIANCE METHOD**

## **SECTION 501**

### **GENERAL**

**501.1 Scope.** The provisions of this chapter shall control the *alteration, addition and change of occupancy* of existing buildings and structures, including *historic buildings* and structures as referenced in Section 301.3.1.

**501.1.1 Compliance with other methods.** *Alterations, additions and changes of occupancy to existing buildings and structures shall comply with the provisions of this chapter or with one of the methods provided in Section 301.3.*

**501.2 Fire-resistance ratings.** Where *approved* by the *code official*, in buildings where an automatic sprinkler system installed in accordance with Section 903.3.1.1 or 903.3.1.2 of the *International Building Code* has been added, and the building is now sprinklered throughout, the required fire-resistance ratings of building elements and materials shall be permitted to meet the requirements of the current building code. Fire assemblies that serve multiple purposes in a building shall comply with all the requirements that are applicable for each of the individual fire assemblies. The building is required to meet the other applicable requirements of the *International Building Code*.

Plans, investigation and evaluation reports, and other data shall be submitted indicating which building elements and materials the applicant is requesting the *code official* to review and approve for determination of applying the current building code fire-resistance ratings. All special construction features, including fire-resistance-rated assemblies and smoke-resistive assemblies, conditions of occupancy, means of egress conditions, fire code deficiencies, *approved* modifications or *approved* alternative materials, design and methods of construction, and equipment applying to the building that impact required fire-resistance ratings shall be identified in the evaluation reports submitted. Where fire-resistance rated assemblies serve more than one function, each function shall be identified and individually evaluated under the requirements of the current code.

**501.3 Health care facilities.** In Group I-2 *facilities*, ambulatory care *facilities* and outpatient clinics, any altered or added portion of an existing electrical or medical gas systems shall be required to meet installation and equipment requirements in NFPA 99.

## **SECTION 502**

### **ADDITIONS**

**502.1 General.** *Additions* to any building or structure shall comply with the requirements of the *International Building Code* for new construction. *Alterations* to the *existing building* or structure shall be made to ensure that the *existing building* or structure together with the *addition* are not less complying with the provisions of the *International Building Code* than the *existing* 2018 2024 North Carolina Existing Building Code

building or structure was prior to the addition. An existing building together with its additions shall comply with the height and area provisions of Chapter 5 of the International Building Code.

**[BS] 502.2 Disproportionate earthquake damage.** A building assigned to Seismic Design Category D, E or F that has sustained disproportionate earthquake damage shall be subject to the requirements for buildings with substantial structural damage to vertical elements of the lateral force-resisting system.

**[BS] 502.3 Flood hazard areas.** For buildings and structures in flood hazard areas established in Section 1612.3 of the International Building Code, or Section R322 of the International Residential Code, as applicable, any addition that constitutes substantial improvement of the existing structure shall comply with the flood design requirements for new construction, and all aspects of the existing structure shall be brought into compliance with the requirements for new construction for flood design.

For buildings and structures in flood hazard areas established in Section 1612.3 of the International Building Code, or Section R322 of the International Residential Code, as applicable, any additions that do not constitute substantial improvement of the existing structure are not required to comply with the flood design requirements for new construction.

**[BS] 502.4 Existing structural elements carrying gravity load.** Any existing gravity load-carrying structural element for which an addition and its related alterations cause an increase in design dead, live or snow load, including snow drift effects, of more than 10 percent shall be replaced or altered as needed to carry the gravity loads required by the International Building Code for new structures. Any existing gravity load-carrying structural element whose vertical load-carrying capacity is decreased as part of the addition and its related alterations shall be considered to be an altered element subject to the requirements of Section 503.3. Any existing element that will form part of the lateral load path for any part of the addition shall be considered to be an existing lateral load-carrying structural element subject to the requirements of Section 502.5.

**Exception:** Buildings of Group R occupancy with not more than five dwelling or sleeping units used solely for residential purposes where the existing building and the addition together comply with the conventional light-frame construction methods of the International Building Code or the provisions of the International Residential Code.

**[BS] 502.5 Existing structural elements carrying lateral load.** Where the addition is structurally independent of the existing structure, existing lateral load-carrying structural elements shall be permitted to remain unaltered. Where the addition is not structurally independent of the existing structure, the existing structure and its addition acting together as a single structure shall be shown to meet the requirements of Sections 1609 and 1613 of the International Building Code using full seismic forces.

**Exceptions:**

1. Any existing lateral load-carrying structural element whose demand-capacity ratio with the addition considered is not more than 10 percent greater than its demand-capacity ratio with the addition ignored shall be permitted to remain unaltered. For purposes of calculating demand-capacity ratios, the demand shall consider applicable load combinations with design lateral loads or forces in accordance with Sections 1609 and 1613 of the International Building Code. For purposes of this exception, comparisons of demand-capacity ratios and calculation of design lateral loads, forces and capacities shall account for the cumulative effects of additions and alterations since original construction.



2. Buildings of Group R occupancy with not more than five dwelling or sleeping units used solely for residential purposes where the *existing building* and the *addition* together comply with the conventional light-frame construction methods of the *International Building Code* or the provisions of the *International Residential Code*. \*

## **SECTION 503**

### **ALTERATIONS**

**503.1 General:** *Alterations shall be such that the existing building or structure is not less complying with the provisions of the International Building Code than the existing building or structure was prior to the alteration.*

#### **Exceptions:**

1. An existing stairway shall not be required to comply with the requirements of Section 1011 of the *International Building Code* where the existing space and construction does not allow a reduction in pitch or slope.
2. Handrails otherwise required to comply with Section 1011.11 of the *International Building Code* shall not be required to comply with the requirements of Section 1014.6 of the *International Building Code* regarding full extension of the handrails where such extensions would be hazardous because of plan configuration.
3. Where provided in below-grade transportation stations, existing and new escalators shall be permitted to have a clear width of less than 32 inches (815 mm).

**[BS] 503.2 Flood hazard areas.** *For buildings and structures in flood hazard areas established in Section 1612.3 of the International Building Code, or Section R322 of the International Residential Code, as applicable, any alteration that constitutes substantial improvement of the existing structure shall comply with the flood design requirements for new construction, and all aspects of the existing structure shall be brought into compliance with the requirements for new construction for flood design.*

*For buildings and structures in flood hazard areas established in Section 1612.3 of the International Building Code, or Section R322 of the International Residential Code, as applicable, any alterations that do not constitute substantial improvement of the existing structure are not required to comply with the flood design requirements for new construction.*

**[BS] 503.3 Existing structural elements carrying gravity load.** *Any existing gravity load-carrying structural element for which an alteration causes an increase in design dead, live or snow load, including snow drift effects, of more than 10 percent shall be replaced or altered as needed to carry the gravity loads required by the International Building Code for new structures. Any existing gravity load-carrying structural element whose gravity load-carrying capacity is decreased as part of the alteration shall be shown to have the capacity to resist the applicable design dead, live and snow loads including snow drift effects required by the International Building Code for new structures.*

#### **Exceptions:**

1. Buildings of Group R occupancy with not more than five dwelling or sleeping units used solely for residential purposes where the altered building complies with the conventional light-frame construction methods of the International Building Code or the provisions of the International Residential Code.
2. Buildings in which the increased dead load is due entirely to the addition of a second layer of roof covering weighing 3 pounds per square foot (0.1437 kN/m<sup>2</sup>) or less over an existing single layer of roof covering.

**[BS] 503.4 Existing structural elements carrying lateral load.** Except as permitted by Section 503.13, where the *alteration* increases design lateral loads, results in a prohibited structural irregularity as defined in ASCE 7, or decreases the capacity of any existing lateral load-carrying structural element, the structure of the altered building or structure shall meet the requirements of Sections 1609 and 1613 of the *International Building Code*. Reduced seismic forces shall be permitted.

**Exceptions:**

1. Any existing lateral load-carrying structural element whose demand-capacity ratio with the alteration considered is not more than 10 percent greater than its demand-capacity ratio with the alteration ignored shall be permitted to remain unaltered. For purposes of calculating demand-capacity ratios, the demand shall consider applicable load combinations with design lateral loads or forces in accordance with Sections 1609 and 1613 of the *International Building Code*. Reduced seismic forces shall be permitted. For purposes of this exception, comparisons of demand-capacity ratios and calculation of design lateral loads, forces and capacities shall account for the cumulative effects of additions and alterations since original construction.
2. Buildings in which the increase in the demand-capacity ratio is due entirely to the addition of rooftop-supported mechanical equipment individually having an operating weight less than 400 pounds (181.4 kg) and where the total additional weight of all rooftop equipment placed after initial construction of the building is less than 10 percent of the roof dead load. For purposes of this exception, “roof” shall mean the roof level above a particular story.

**[BS] 503.5 Seismic Design Category F.** Deleted.

**[BS] 503.6 Bracing for unreinforced masonry parapets on reroofing.** Deleted.

**[BS] 503.7 Anchorage for concrete and reinforced masonry walls.** Deleted.

**[BS] 503.8 Anchorage for unreinforced masonry walls in major alterations.** Deleted.

**[BS] 503.9 Bracing for unreinforced masonry parapets in major alterations.** Deleted.

**[BS] 503.10 Anchorage of unreinforced masonry partitions in major alterations.** Deleted.

**[BS] 503.11 Substantial structural alteration.** Where the *work area* exceeds 50 percent of the building area and where work involves a *substantial structural alteration*, the lateral load-resisting system of the altered building shall satisfy the requirements of Sections 1609 and 1613 of the *International Building Code*. Reduced seismic forces shall be permitted.

**Exceptions:**

1. Buildings of Group R occupancy with not more than five dwelling or sleeping units used solely for residential purposes that are altered based on the conventional light-frame construction methods of the *International Building Code* or in compliance with the provisions of the *International Residential Code*.
2. Where the intended *alteration* involves only the lowest story of a building, only the lateral load-resisting components in and below that story need comply with this section.

**[BS] 503.12 Roof diaphragms resisting wind loads in high-wind regions.** Deleted.

**[BS] 503.13 Voluntary lateral force-resisting system alterations.** Structural *alterations* that are intended exclusively to improve the lateral force-resisting system and are not required by other sections of this code shall not be required to meet the requirements of Section 1609 or 1613 of the *International Building Code*, provided that all of the following apply:

1. The capacity of existing structural systems to resist forces is not reduced.

2. New structural elements are detailed and connected to existing or new structural elements as required by the *International Building Code* for new construction.
3. New or relocated nonstructural elements are detailed and connected to existing or new structural elements as required by the *International Building Code* for new construction.
4. The *alterations* do not create a structural irregularity as defined in ASCE 7 or make an existing structural irregularity more severe. \*

**503.14 Smoke compartments.** In Group I-2 occupancies where the *alteration* is on a story used for sleeping rooms, the story shall be divided into not less than two compartments by smoke barrier walls in accordance with Section 407.5 of the *International Building Code* as required for new construction. \*

**503.15 Refuge areas.** Where *alterations* affect the configuration of an area utilized as a refuge area, the capacity of the refuge area shall not be reduced below the required capacity of the refuge area for horizontal exits in accordance with Section 1026.4 of the *International Building Code*.

Where the horizontal exit also forms a smoke compartment, the capacity of the refuge area for Group I-1, I-2 and I-3 occupancies and Group B ambulatory care *facilities* shall not be reduced below that required in Sections 407.5.3, 408.6.2, 420.6.1 and 422.3.2 of the *International Building Code*, as applicable.

**503.16 Enhanced classroom acoustics.** In Group E occupancies, where the *work area* exceeds 50 percent of the building area, enhanced classroom acoustics shall comply with Section 1207.5 of the *International Building Code* as required for new construction.

**503.17 Locking arrangements in educational occupancies.** In Group E occupancies, Group B educational occupancies and Group I-4 occupancies, egress doors with locking arrangements designed to keep intruders from entering the room shall comply with Section 1010.2.8 of the *International Building Code*.

(re-visit after the review of 2024 NCBC)

**503.18 Two-way communications systems.** Where the *work area* for *alterations* exceeds 50 percent of the building area and the building has elevator service, a two-way communication systems shall be provided where required by Section 1009.8 of the *International Building Code*.

## **SECTION 504**

### **FIRE ESCAPES**

**[BE] 504.1 Where permitted.** Fire escapes shall be permitted only as provided for in Sections 504.1.1 through 504.1.4.

**[BE] 504.1.1 New buildings.** Deleted.

**[BE] 504.1.2 Existing fire escapes.** Existing fire escapes shall continue to be accepted as a component in the means of egress in *existing buildings* only.

**[BE] 504.1.3 New fire escapes.** New fire escapes for *existing buildings* shall be permitted only where exterior stairways cannot be utilized because of lot lines limiting stairway size or because of sidewalks, alleys or roads at grade level. New fire escapes shall not incorporate ladders or access by windows. This provision shall not apply to additions.

**BE] 504.1.4 Limitations.** Fire escapes shall comply with this section and shall not constitute more than 50 percent of the required number of exits nor more than 50 percent of the required exit capacity.

**BE] 504.2 Location.** Where located on the front of the building and where projecting beyond the building line, the lowest landing shall be not less than 7 feet (2134 mm) or more than 12 feet (3658 mm) above grade, and shall be equipped with a counterbalanced stairway to the street. In alleyways and thoroughfares less than 30 feet (9144 mm) wide, the clearance under the lowest landing shall be not less than 12 feet (3658 mm).

**BE] 504.3 Construction.** The fire escape shall be designed to support a live load of 100 pounds per square foot (4788 Pa) and shall be constructed of steel or other *approved noncombustible materials*. Fire escapes constructed of wood not less than nominal 2 inches (51 mm) thick are permitted on buildings of Type V construction. Walkways and railings located over or supported by combustible roofs in buildings of Type III and IV construction are permitted to be of wood not less than nominal 2 inches (51 mm) thick.

**BE] 504.4 Dimensions.** Stairways shall be not less than 22 inches (559 mm) wide with risers not more than, and treads not less than, 8 inches (203 mm) and landings at the foot of stairways not less than 40 inches (1016 mm) wide by 36 inches (914 mm) long, located not more than 8 inches (203 mm) below the door.

**BE] 504.5 Opening protectives.** Doors and windows within 10 feet (3048 mm) of fire escape stairways shall be protected with  $\frac{3}{4}$ -hour opening protectives.

**Exception:** Opening protection shall not be required in buildings equipped throughout with an *approved* automatic sprinkler system.

**504.6 Marking** The open space under fire escape stairways shall not be used for any purpose. Approved signs or other approved markings that include the words FIRE ESCAPE – KEEP CLEAR shall be provided to prohibit the obstruction thereof.

## **SECTION 505**

### **WINDOWS AND EMERGENCY ESCAPE OPENINGS**

**505.1 Replacement windows.** The installation or replacement of windows shall be as required for new installations.

**505.2 Window opening control devices on replacement windows.** In Group R-2 or R-3 buildings containing dwelling units, and one- and two-family dwellings and townhouses regulated by the *International Residential Code*, window opening control devices or fall prevention devices complying with ASTM F2090 shall be installed where an existing window is replaced and where all of the following apply to the replacement window:

1. The window is operable.
2. One of the following applies:
  - 2.1. The window replacement includes replacement of the sash and frame.
  - 2.2. The window replacement includes the sash only where the existing frame remains.
3. One of the following applies:
  - 3.1. In Group R-2 or R-3 buildings containing dwelling units, the bottom of the clear opening of the window opening is at a height less than 36 inches (915 mm) above the finished floor.

3.2. In one- and two-family dwellings and townhouses regulated by the *International Residential Code*, the bottom of the clear opening of the window opening is at a height less than 24 inches (610 mm) above the finished floor.

4. The window will permit openings that will allow passage of a 4-inch-diameter (102 mm) sphere when the window is in its largest opened position.

5. The vertical distance from the bottom of the clear opening of the window opening to the finished grade or other surface below, on the exterior of the building, is greater than 72 inches (1829 mm).

**Exception:** Operable windows where the bottom of the clear opening of the window opening is located more than 75 feet (22 860 mm) above the finished grade or other surface below, on the exterior of the room, space or building, and that are provided with window fall prevention devices that comply with ASTM F2006.

**505.3 Replacement window emergency escape and rescue openings.** Where windows are required to provide *emergency escape and rescue openings* in Group E classrooms, Group R-2 and R-3 occupancies and one- and two-family dwellings and townhouses regulated by the *International Residential Code*, replacement windows shall be exempt from the requirements of Section 1031.3 of the *International Building Code* and Section R310.2 of the *International Residential Code*, provided that the replacement window meets the following conditions:

1. The replacement window is the manufacturer's largest standard size window that will fit within the existing frame or existing rough opening. The replacement window shall be permitted to be of the same operating style as the existing window or a style that provides for an equal or greater window opening area than the existing window.

2. Where the replacement of the window is part of a *change of occupancy*, it shall comply with Section 1011.5.6.

**505.3.1 Control devices.** Window opening control devices or fall prevention devices complying with ASTM F2090 shall be permitted for use on windows required to provide *emergency escape and rescue openings*. After operation to release the control device allowing the window to fully open, the control device shall not reduce the net clear opening area of the window unit. *Emergency escape and rescue openings* shall be operational from the inside of the room without the use of keys or tools.

**505.4 Bars, grilles, covers or screens.** Bars, grilles, covers, screens or similar devices are permitted to be placed over *emergency escape and rescue openings*, bulkhead enclosure or window wells that serve such openings, provided all of the following conditions are met:

1. The minimum net clear opening size complies with the code that was in effect at the time of construction.

2. Such devices shall be releasable or removable from the inside without the use of a key, tool or force greater than that which is required for normal operation of the escape and rescue opening.

3. Where such devices are installed, they shall not reduce the net clear opening of the emergency escape and rescue openings.

4. Smoke alarms shall be installed in accordance with Section 907.2.10 of the *International Building Code*.

**SECTION 506**  
**CHANGE OF OCCUPANCY**

**506.1 Compliance.** A change of occupancy shall not be made in any building unless that building is made to comply with the requirements of the *International Building Code* for the use or occupancy. Changes of occupancy in a building or portion thereof shall be such that the *existing building* is not less complying with the provisions of this code than the *existing building* or structure was prior to the change. Subject to the approval of the *code official*, changes of occupancy shall be permitted without complying with all of the requirements of this code for the new occupancy, provided that the new occupancy is less hazardous, based on life and fire risk, than the existing occupancy.

**Exception:** The building need not be made to comply with Chapter 16 of the *International Building Code* unless required by Section 506.5.

**506.1.1 Change in the character of use.** A change of occupancy with no *change of occupancy* classification shall not be made to any structure that will subject the structure to any special provisions of the applicable International Codes, without approval of the *code official*. Compliance shall be only as necessary to meet the specific provisions and is not intended to require the entire building be brought into compliance.

**506.2 Certificate of occupancy.** A certificate of occupancy shall be issued where it has been determined that the requirements for the new occupancy classification have been met.

**506.3 Stairways.** An existing stairway shall not be required to comply with the requirements of Section 1011 of the *International Building Code* where the existing space and construction does not allow a reduction in pitch or slope.

**506.4 Existing emergency escape and rescue openings.** Where a *change of occupancy* would require an *emergency escape and rescue opening* in accordance with Section 1031.1 of the *International Building Code*, operable windows serving as the *emergency escape and rescue opening* shall comply with the following

1. An existing operable window shall provide a minimum net clear opening of 4 square feet (0.38 m<sup>2</sup>) with a minimum net clear opening height of 22 inches (559 mm) and a minimum net clear opening width of 20 inches (508 mm).
2. A replacement window where such window complies with both of the following:
  - 2.1. The replacement window meets the size requirements in Item 1.
  - 2.2. The replacement window is the manufacturer's largest standard size window that will fit within the existing frame or existing rough opening. The replacement window shall be permitted to be of the same operating style as the existing window or a style that provides for an equal or greater window opening area than the existing window.

**506.5 Structural.** Any building undergoing a *change of occupancy* shall satisfy the requirements of this section.

**506.5.1 Live loads.** Structural elements carrying tributary live loads from an area with a *change of occupancy* shall satisfy the requirements of Section 1607 of the *International Building Code*. Design live loads for areas of new occupancy shall be based on Section 1607 of the *International Building Code*. Design live loads for other areas shall be permitted to use previously *approved* design live loads.

**Exception:** Structural elements whose demand-capacity ratio considering the *change of occupancy* is not more than 10 percent greater than the demand-capacity ratio based on previously *approved* live loads need not comply with this section.

**506.5.2 Snow and wind loads.** Where a *change of occupancy* results in a structure being assigned to a higher *risk category*, the structure shall satisfy the requirements of Sections 1608 and 1609 of the *International Building Code* for the new *risk category*.

**Exception:** Where the area of the new occupancy is less than 10 percent of the building area, compliance with this section is not required. The cumulative effect of occupancy changes over time shall be considered.

**506.5.3 Seismic loads (seismic force-resisting system).** Where a *change of occupancy* results in a building being assigned to a higher *risk category*, or where the change is from a Group S or Group U occupancy to any occupancy other than Group S or Group U, the building shall satisfy the requirements of Section 1613 of the *International Building Code* for the new *risk category* using full seismic forces.

**Exceptions:**

1. Where the area of the new occupancy is less than 10 percent of the building area, the occupancy is not changing from a Group S or Group U occupancy, and the new occupancy is not assigned to *Risk Category IV*, compliance with this section is not required. The cumulative effect of occupancy changes over time shall be considered.
2. Where a *change of use* results in a building being reclassified from *Risk Category I* or *II* to *Risk Category III* and the seismic coefficient,  $S_{DS}$ , is less than 0.33, compliance with this section is not required.
3. Unreinforced masonry bearing wall buildings assigned to *Risk Category III* and to Seismic Design Category A or B, shall be permitted to use Appendix Chapter A1 of this code.
4. Where the change is from a Group S or Group U occupancy and there is no change of risk category, use of reduced seismic forces shall be permitted.

**506.5.4 Access to Risk Category IV.** Any structure that provides operational access to an adjacent structure assigned to *Risk Category IV* as the result of a *change of occupancy* shall itself satisfy the requirements of Sections 1608, 1609 and 1613 of the *International Building Code*. For compliance with Section 1613, *International Building Code*-level seismic forces shall be used. Where operational access to the *Risk Category IV* structure is less than 10 feet (3048 mm) from either an interior lot line or from another structure, access protection from potential falling debris shall be provided.

**506.6 Enhanced classroom acoustics.** In Group E occupancies, where the *work area* exceeds 50 percent of the building area, enhanced classroom acoustics shall comply with Section 1207.5 of the *International Building Code* as required for new construction.

**506.7 Energy conservation.** Spaces undergoing a change of occupancy shall comply with the *NC Energy Conservation Code*.

**SECTION 507**  
**HISTORIC BUILDINGS**

**507.1 Historic buildings.** The provisions of this code that require improvements relative to a building's existing condition or, in the case of repairs, that require improvements relative to a building's predamage condition, shall not be mandatory for historic buildings unless specifically required by this section.

**507.2 Life safety hazards.** The provisions of this code shall apply to historic buildings judged by the code official to constitute a distinct life safety hazard.

**[BS] 507.3 Flood hazard areas.** Within flood hazard areas established in accordance with Section 1612.3 of the International Building Code, or Section R322 of the International Residential Code, as applicable, where the work proposed constitutes substantial improvement, the building shall be brought into compliance with Section 1612 of the International Building Code, or Section R322 of the International Residential Code, as applicable.

**Exception:** Historic buildings meeting any of the following criteria need not be brought into compliance:

1. Listed or preliminarily determined to be eligible for listing in the National Register of Historic Places.
2. Determined by the Secretary of the US Department of Interior as contributing to the historical significance of a registered historic district or a district preliminarily determined to qualify as an historic district.
3. Designated as historic under a state or local historic preservation program that is approved by the Department of Interior.

**[BS] 507.4 Structural.** Historic buildings shall comply with the applicable structural provisions in this chapter.

**Exceptions:**

1. The code official shall be authorized to accept existing floors and existing live loads and to approve operational controls that limit the live load on any floor.
2. Repair of substantial structural damage is not required to comply with Sections 405.2.3, and 405.2.4. Substantial structural damage shall be repaired in accordance with Section 405.2.1.

**CHAPTER 6**  
**REPAIRS**

**SECTION 601**  
**GENERAL**

**601.1 Scope.**

~~Repairs as described in Section 502 shall comply with the requirements of this chapter. Repairs to historic buildings need only comply with Chapter 12.~~



### **601.2 Conformance.**

The work shall not make the building less conforming than it was before the *repair* was undertaken.

### **~~[BS] 601.3 Flood hazard areas.~~**

~~In flood hazard areas, repairs that constitute *substantial improvement* shall require that the building comply with Section 1612 of the *International Building Code*, or Section R322 of the *International Residential Code*, as applicable.~~

## **SECTION 602 BUILDING ELEMENTS AND MATERIALS**

### **602.1 Existing building materials.**

~~Materials already in use in a building in compliance with requirements or approvals in effect at the time of their erection or installation shall be permitted to remain in use unless determined by the *code official* to render the building or structure unsafe or *dangerous* as defined in Chapter 2.~~

### **602.2 New and replacement materials.**

~~Except as otherwise required or permitted by this code, materials permitted by the applicable code for new construction shall be used. Like materials shall be permitted provided no *dangerous* or *unsafe* condition, as defined in Chapter 2, is created. Hazardous materials, such as asbestos and lead-based paint, shall not be used where the code for new construction would not permit their use in buildings of similar occupancy, purpose and location.~~

### **602.3 Glazing in hazardous locations.**

~~Replacement glazing in hazardous locations shall comply with the safety glazing requirements of the *International Building Code* or *International Residential Code* as applicable.~~

~~**Exception:** Glass block walls, louvered windows, and jalousies repaired with like materials.~~

### **602.4 Wind borne debris protection.**

~~Replacement of window units shall require compliance with Section 1609.1.2 of the *North Carolina Building Code* or Section R609.6 of the *North Carolina Residential Code*. Replacement of individual glass panes or sashes shall not require compliance with Sections~~

~~1609.1.2 and R609.6.~~

## **SECTION 603 FIRE PROTECTION**

### **603.1 General.**

Repairs shall be done in a manner that maintains the level of fire protection that is existing.

## **SECTION 604 MEANS OF EGRESS**

**604.1 General.**

Repairs shall be done in a manner that maintains the level of protection that is existing for the means of egress.

**SECTION 605  
ACCESSIBILITY**

**605.1 General.**

Repairs shall be done in a manner that maintains the level of accessibility that exists.

**SECTION 606  
STRUCTURAL**

**[BS] 606.1 General.**

Structural repairs shall be in compliance with this section and Section 601.2. Regardless of the extent of structural or nonstructural damage, *dangerous* conditions shall be eliminated. Regardless of the scope of *repair*, new structural members and connections used for *repair* or *rehabilitation* shall comply with the detailing provisions of the *International Building Code* for new buildings of similar structure, purpose and location.

**[BS] 606.2 Repairs to damaged buildings.**

Repairs to damaged buildings shall comply with this section.

**[BS] 606.2.1 Repairs for less than substantial structural damage.**

For damage less than *substantial structural damage*, the damaged elements shall be permitted to be restored to their predamage condition.

**[BS] 606.2.2 Substantial structural damage to vertical elements of the lateral force-resisting system.**

A building that has sustained *substantial structural damage* to the vertical elements of its lateral force-resisting system shall be evaluated in accordance with Section 606.2.2.1, and either repaired in accordance with Section 606.2.2.2 or repaired and rehabilitated in accordance with Section 606.2.2.3, depending on the results of the evaluation.

**Exceptions:**

1. Buildings assigned to Seismic Design Category A, B, or C whose substantial structural damage was not caused by earthquake need not be evaluated or rehabilitated for load combinations that include earthquake effects.
2. One and two family dwellings need not be evaluated or rehabilitated for load combinations that include earthquake effects.

**[BS] 606.2.2.1 Evaluation.**

The building shall be evaluated by a registered design professional, and the evaluation findings shall be

submitted to the *code official*. The evaluation shall establish whether the damaged building, if repaired to its predamage state, would comply with the provisions of the *International Building Code* for load combinations that include wind or earthquake effects, except that the seismic forces shall be the reduced *International Building Code* level seismic forces.

**[BS] 606.2.2.2 Extent of repair for compliant buildings.**

If the evaluation establishes that the building in its predamage condition complies with the provisions of Section 606.2.2.1, then the damaged elements shall be permitted to be restored to their predamage condition.

**[BS] 606.2.2.3 Extent of repair for noncompliant buildings.**

If the evaluation does not establish that the building in its predamage condition complies with the provisions of Section 606.2.2.1, then the building shall be rehabilitated to comply with the provisions of this section. The wind loads for the *repair* and *rehabilitation* shall be those required by the building code in effect at the time of original construction, unless the damage was caused by wind, in which case the wind loads shall be in accordance with the *International Building Code*. The seismic loads for this *rehabilitation* design shall be those required by the building code in effect at the time of original construction, but not less than the reduced *International Building Code* level seismic forces.

**[BS] 606.2.3 Substantial structural damage to gravity load-carrying components.**

Gravity load-carrying components that have sustained *substantial structural damage* shall be rehabilitated to comply with the applicable provisions for dead and live loads in the *International Building Code*. Snow loads shall be considered if the *substantial structural damage* was caused by or related to snow load effects. Undamaged gravity load-carrying components that receive dead, live or snow loads from rehabilitated components shall also be rehabilitated if required to comply with the design loads of the *rehabilitation* design.

**[BS] 606.2.3.1 Lateral force-resisting elements.**

Regardless of the level of damage to gravity elements of the lateral force-resisting system, if substantial structural damage to gravity load-carrying components was caused primarily by wind or seismic effects, then the building shall be evaluated in accordance with Section 606.2.2.1 and, if noncompliant, rehabilitated in accordance with Section 606.2.2.3.

**Exceptions:**

1. Buildings assigned to Seismic Design Category A, B, or C whose substantial structural damage was not caused by earthquake need not be evaluated or rehabilitated for load combinations that include earthquake effects.
2. One and two family dwellings need not be evaluated or rehabilitated for load combinations that include earthquake effects.

**[BS] 606.2.4 Flood hazard areas.**

In *flood hazard areas*, buildings that have sustained *substantial damage* shall be brought into compliance with Section 1612 of the *International Building Code*, or Section R322 of the *International Residential Code*, as applicable.

## **SECTION 607 ELECTRICAL**

### **607.1 Material.**

~~Existing electrical wiring and equipment undergoing *repair* shall be allowed to be repaired or replaced with like material.~~

#### **607.1.1 Receptacles.**

~~Replacement of electrical receptacles shall comply with the applicable requirements of Section 406.4(D) of NFPA 70.~~

#### **607.1.2 Plug fuses.**

~~Plug fuses of the Edison-base type shall be used for replacements only where there is no evidence of over fusing or tampering per applicable requirements of Section 240.51(B) of NFPA 70.~~

#### **607.1.3 Nongrounding-type receptacles.**

~~For replacement of nongrounding-type receptacles with grounding-type receptacles and for branch circuits that do not have an equipment grounding conductor in the branch circuitry, the grounding conductor of a grounding-type receptacle outlet shall be permitted to be grounded to any accessible point on the grounding electrode system or to any accessible point on the grounding electrode conductor in accordance with Section 250.130(C) of NFPA 70.~~

#### **607.1.4 Group I-2 receptacles.**

~~Non "hospital grade" receptacles in patient bed locations of Group I-2 shall be replaced with "hospital grade" receptacles, as required by NFPA 99 and Article 517 of NFPA 70.~~

#### **607.1.5 Grounding of appliances.**

~~Frames of electric ranges, wall-mounted ovens, counter-mounted cooking units, clothes dryers and outlet or junction boxes that are part of the existing branch circuit for these appliances shall be permitted to be grounded to the grounded circuit conductor in accordance with Section 250.140 of NFPA 70.~~

## **SECTION 608 MECHANICAL**

### **608.1 General.**

~~Existing mechanical systems undergoing *repair* shall not make the building less conforming than it was before the *repair* was undertaken.~~

### **608.2 Mechanical draft systems for manually fired appliances and fireplaces.**

~~A mechanical draft system shall be permitted to be used with manually fired appliances and fireplaces where such a system complies with all of the following requirements:~~

- ~~1. The mechanical draft device shall be listed and installed in accordance with the manufacturer's installation instructions.~~

~~2.— A device shall be installed that produces visible and audible warning upon failure of the mechanical draft device or loss of electrical power at any time that the mechanical draft device is turned on. This device shall be equipped with a battery backup if it receives power from the building wiring.~~

~~3.— A smoke detector shall be installed in the room with the appliance or fireplace. This device shall be equipped with a battery backup if it receives power from the building wiring.~~

## **SECTION 609 PLUMBING**

### **~~609.1 General.~~**

~~Existing plumbing systems undergoing *repair* shall not make the building less conforming than it was before the *repair* was undertaken.~~

### **~~609.12 Materials.~~**

~~Plumbing materials and supplies shall not be used for repairs that are prohibited in the *International Plumbing Code*.~~

### **~~609.23 Water closet replacement.~~**

~~The maximum water consumption flow rates and quantities for all replaced water closets shall be 1.6 gallons (6 L) per flushing cycle.~~

**Exception:** Blowout design water closets [3.5 gallons (13 L) per flushing cycle].

### **~~609.4 Water supply system test.~~**

~~Existing water supply systems that are repaired shall be allowed to be tested and proved tight under a water pressure of normal operating pressure of the existing water supply system. The pressure shall be held at least 15 minutes.~~

## **SECTION 610**

### **ENERGY CONSERVATION**

### **610.1 General.**

*Repair* of building systems shall not make the building less conforming than it was before the *repair* was undertaken.

### **610.2 Materials.**

Portions of walls that are part of the building thermal envelope shall be insulated in accordance with the *North Carolina Energy Conservation Code* when the *repair* requires the removal of either the interior or exterior wall membrane such that the wall cavity is exposed during the *repair*.

**Exception:** Wall cavities containing existing insulation material.

### **610.3 Glazing.**

*Repair* requiring the replacement of window units shall comply with the requirements of the *North Carolina Energy Conservation Code*. *Repair* requiring the replacement of individual glass panes or sashes shall not require compliance with the *U*-value requirements of the *North Carolina Energy Conservation Code*.

**Exception:** Historic structures where compliance with the *North Carolina Energy Conservation Code* would conflict with the historic nature of the structure are not required to comply with the *North Carolina Energy Conservation Code* but shall have an *U*-value equal to or greater than the existing glazing.

## **CLASSIFICATION OF WORK**

**601.1 Scope.** The provisions of this chapter shall be used in conjunction with Chapters 7 through 12 and shall apply to the alteration, addition and change of occupancy of existing structures, including historic and moved structures, as referenced in Section 301.3.2. The work performed on an existing building shall be classified in accordance with this chapter.

**601.1.1 Compliance with other alternatives.** Alterations, additions and changes of occupancy to existing structures shall comply with the provisions of Chapters 7 through 12 or with one of the alternatives provided in Section 301.3.

**601.2 Work area.** The work area, as defined in Chapter 2, shall be identified on the construction documents.

## **SECTION 602**

### **ALTERATION—LEVEL 1**

**602.1 Scope.** Level 1 alterations include the removal and replacement or the covering of existing materials, elements, equipment or fixtures using new materials, elements, equipment or fixtures that serve the same purpose.

**602.2 Application.** Level 1 alterations shall comply with the provisions of Chapter 7.

## **SECTION 603**

### **ALTERATION—LEVEL 2**

**603.1 Scope.** Level 2 alterations include the addition or elimination of any door or window, the reconfiguration or extension of any system, or the installation of any additional equipment, and shall apply where the work area is equal to or less than 50 percent of the building area.

**Exception:** The movement or addition of nonfixed and movable fixtures, cases, racks, counters and partitions not over 5 feet 9 inches (1753 mm) in height shall not be considered a Level 2 alteration.

**603.2 Application.** Level 2 alterations shall comply with the provisions of Chapter 7 for Level 1 alterations as well as the provisions of Chapter 8.

## **SECTION 604**

### **ALTERATION—LEVEL 3**

**604.1 Scope.** Level 3 alterations apply where the work area exceeds 50 percent of the building area- in any 12-month time period.

**Exception:** Alterations limited to displays or showrooms in Group M occupancies.

**604.2 Application.** Level 3 alterations shall comply with the provisions of Chapters 7 and 8 for Level 1 and 2 alterations, respectively, as well as the provisions of Chapter 9.

## **SECTION 605**

### **CHANGE OF OCCUPANCY**

**605.1 Scope.** Change of occupancy provisions apply where the activity is classified as a change of occupancy as defined in Chapter 2.

**605.2 Application.** Changes of occupancy shall comply with the provisions of Chapter 10.

## **SECTION 606**

### **ADDITIONS**

**606.1 Scope.** Provisions for *additions* shall apply where work is classified as an *addition* as defined in Chapter 2.

**606.2 Application.** *Additions to existing buildings* shall comply with the provisions of Chapter 11.

## **SECTION 607**

### **HISTORIC BUILDINGS**

**607.1 Scope.** *Historic building* provisions shall apply to buildings classified as historic as defined in Chapter 2.

**607.2 Application.** Except as specifically provided for in Chapter 12, *historic buildings* shall comply with applicable provisions of this code for the type of work being performed.



# CHAPTER 7 ALTERATIONS—LEVEL 1

## SECTION 701 GENERAL

### 701.1 Scope.

Level 1 *alterations* as described in Section ~~503~~ 602 shall comply with the requirements of this chapter. Level 1 *alterations* to *historic buildings* shall comply with this chapter, except as modified in Chapter 12.

### 701.2 Conformance.

An *existing building* or portion thereof shall not be altered such that the building becomes less safe than its existing condition.

**Exception:** Where the current level of safety or sanitation is proposed to be reduced, the portion altered shall conform to the requirements of the *International Building Code*.

### [BS] 701.3 Flood hazard areas.

In *flood hazard areas*, *alterations* that constitute *substantial improvement* shall require that the building comply with Section 1612 of the *International Building Code*, or Section R322 of the *International Residential Code*, as applicable,

## SECTION 702 BUILDING ELEMENTS AND MATERIALS

### 702.1 Interior finishes.

All newly installed interior wall and ceiling finishes shall comply with Chapter 8 of the *International Building Code*.

### 702.2 Interior floor finish.

New interior floor finish, including new carpeting used as an interior floor finish material, shall comply with Section 804 of the *International Building Code*.

### 702.3 Interior trim.

All newly installed interior trim materials shall comply with Section 806 of the *International Building Code*.

### 702.4 Window opening control devices.

In Group R-2 or R-3 buildings containing dwelling units and one- and two-family dwellings and townhouses regulated by the *International Residential Code*, window opening control devices complying with ASTM F 2090 shall be installed where an existing window is replaced and where all of the following apply to the replacement window:

1. The window is operable;
2. The window replacement includes replacement of the sash and the frame;
3. One of the following applies:
  - 3.1. In Group R-2 or R-3 buildings containing dwelling units, the top of the sill of the window opening is at a height less than 36 inches (915 mm) above the finished floor; or
  - 3.2. In one- and two-family dwellings and town-houses regulated by the *International Residential Code*, the top sill of the window opening is at a height less than 24 inches (610 mm) above the finished floor;
4. The window will permit openings that will allow passage of a 4-inch-diameter (102 mm) sphere when the window is in its largest opened position; and
5. The vertical distance from the top of the sill of the window opening to the finished grade or other surface below, on the exterior of the building, is greater than 72 inches (1829 mm).

The window opening control device, after operation to release the control device allowing the window to fully open, shall not reduce the minimum net clear opening area of the window unit to less than the area required by the *International Building Code*.

**Exceptions:**

1. Operable windows where the top of the sill of the window opening is located more than 75 feet (22 860 mm) above the finished grade or other surface below, on the exterior of the room, space or building, and that are provided with window fall prevention devices that comply with ASTM F 2006.
2. Operable windows with openings that are provided with window fall prevention devices that comply with ASTM F 2090.

**702.5 Emergency escape and rescue openings.**

Where windows are required to provide emergency escape and rescue openings in Group R-2 and R-3 occupancies and one- and two-family dwellings and townhouses regulated by the *International Residential Code*, replacement windows in Group E classrooms, shall be exempt from the requirements of Sections 1030.2, 1030.3 and 1030.5 of the *International Building Code* and Sections R310.21 and R310.2.3 of the *International Residential Code* accordingly, provided the replacement window is the manufacturer's largest standard size window that will fit within the existing frame or existing rough opening. The replacement window shall be permitted to be of the same operating style as the existing window or a style that provides for an equal or greater window opening area than the existing window.

Window opening control devices complying with ASTM F 2090 shall be permitted for use on windows required to provide *emergency escape and rescue openings*.

### **702.6 Materials and methods.**

All new work shall comply with the materials and methods requirements in the *International Building Code*, *International Energy Conservation Code*, *International Mechanical Code*, and *International Plumbing Code*, as applicable, that specify material standards, detail of installation and connection, joints, penetrations, and continuity of any element, component, or system in the building.

#### **[FG] 702.6.1 International Fuel Gas Code.**

The following sections of the *International Fuel Gas Code* shall constitute the fuel gas materials and methods requirements for Level 1 alterations.

1. All of Chapter 3, entitled "General Regulations," except Sections 303.7 and 306.
2. All of Chapter 4, entitled "Gas Piping Installations," except Sections 401.8 and 402.3.
  - 2.1. Sections 401.8 and 402.3 shall apply when the work being performed increases the load on the system such that the existing pipe does not meet the size required by code. Existing systems that are modified shall not require resizing as long as the load on the system is not increased and the system length is not increased even if the altered system does not meet code minimums.
3. All of Chapter 5, entitled "Chimneys and Vents."
4. All of Chapter 6, entitled "Specific Appliances."

## **SECTION 703 FIRE PROTECTION**

### **703.1 General.**

*Alterations* shall be done in a manner that maintains the level of fire protection that is existing.

### **703.2 Smoke and carbon monoxide alarms.**

Smoke and carbon monoxide alarms shall be provided and installed in accordance with Section 804.4.

## **SECTION 704 MEANS OF EGRESS**

#### **704.1 General.**

Alterations shall be done in a manner that maintains the level of protection that is existing for the means of egress.

704.1.1 Projections in nursing home corridors. In Group I-2, Condition 1 occupancies, where the corridor is at least 96 inches (2438 mm) wide, projections into the corridor width are permitted in accordance with Section 407.4.3 of the International Building Code.

704.2 Casework. Addition, alteration or reconfiguration of nonfixed and movable cases, counters and partitions not over 5 feet 9 inches (1753 mm) in height shall maintain the required means of egress path.

704.3 Locking arrangements in educational occupancies. In Group E occupancies, Group B educational occupancies and Group I-4 occupancies, egress doors with locking arrangements designed to keep intruders from entering the room shall comply with Section 1010.2.8 of the International Building Code.

### **SECTION 705 ACCESSIBILITY**

~~Deleted  
(Relocated to Section 806)~~

### **SECTION 706 REROOFING**

#### **[BS] 706.4 705.1 General.**

Materials and methods of application used for recovering or replacing an existing roof covering shall comply with the requirements of Chapter 15 of the *International Building Code*.

#### **Exceptions:**

- ~~1. Reroofing shall not be required to meet the minimum design slope requirement of one-quarter unit vertical in 12 units horizontal (2-percent slope) in Section 1507 of the International Building Code for roofs that provide positive roof drainage.~~
- ~~2. Reroofing for buildings in the primary or secondary fire district shall follow the provisions of Appendix D of the North Carolina Building Code.~~
1. Roof replacement or roof recover of existing low-slope roof coverings shall not be required to meet the minimum design slope requirement of  $\frac{1}{4}$  unit vertical in 12 units horizontal (2-percent slope) in Section 1507 of the International Building Code for roofs that provide positive roof drainage.
2. Recovering or replacing an existing roof covering shall not be required to meet the requirement for secondary (emergency overflow) drains or scuppers in Section 1502 of the International Building Code for roofs that provide for positive roof drainage. For the purposes of this exception, existing secondary drainage or scupper systems required in accordance with this code shall not be removed unless they are replaced by secondary drains or scuppers designed and installed in accordance with Section 1502 of the International Building Code. \*

3. Reroofing for buildings in the primary or secondary fire district shall follow the provisions of Appendix D of the *North Carolina Building Code*.

**[BS] 706.2 Structural and construction loads.**

~~Structural roof components shall be capable of supporting the roof-covering system and the material and equipment loads that will be encountered during installation of the system.~~

**[BS] 705.2 Roof replacement.** *Roof replacement* shall include the removal of all existing layers of roof coverings down to the roof deck.

**Exception:** Where the existing roof assembly includes an ice barrier membrane that is adhered to the roof deck, the existing ice barrier membrane shall be permitted to remain in place and covered with an additional layer of ice barrier membrane in accordance with Section 1507 of the *International Building Code* and Section R905 of the *International Residential Code*.

**[BS] 705.2.1 Roof recover.** The installation of a new roof covering over an existing roof covering shall be permitted where any of the following conditions occur:

1. The new roof covering is installed in accordance with the roof covering manufacturer's *approved* instructions.
2. Complete and separate roofing systems, such as standing-seam metal roof panel systems, that are designed to transmit the roof loads directly to the building's structural system and that do not rely on existing roofs and roof coverings for support, are installed.
3. Metal panel, metal shingle and concrete and clay tile roof coverings are installed over existing wood shake roofs in accordance with Section 705.3.
4. A new protective *roof coating* is applied over an existing protective *roof coating*, a metal roof panel, metal roof shingles, mineral-surfaced roll roofing, a built-up roof, modified bitumen roofing, thermoset and thermoplastic single-ply roofing or a spray polyurethane foam roofing system.

**[BS] 705.2.1.1 Exceptions.** A roof recover shall not be permitted where any of the following conditions occur:

1. The existing roof or roof covering is water soaked or has deteriorated to the point that the existing roof or roof covering is not adequate as a base for additional roofing.
2. The existing roof covering is slate, clay, cement or asbestos-cement tile.
3. The existing roof has two or more applications of any type of roof covering.

**[BS] 706.3 Recovering versus replacement.**

~~New roof coverings shall not be installed without first removing all existing layers of roof coverings down to the roof deck where any of the following conditions occur:~~

- ~~1. Where the existing roof or roof covering is water soaked or has deteriorated to the point that the existing roof or roof covering is not adequate as a base for additional roofing.~~
- ~~2. Where the existing roof covering is wood shake, slate, clay, cement or asbestos-cement tile.~~
- ~~3. Where the existing roof has two or more applications of any type of roof covering.~~

**Exceptions:**

- ~~1. Complete and separate roofing systems, such as standing seam metal roof systems, that are designed to transmit the roof loads directly to the building's structural system and that do not rely on existing roofs and roof coverings for support, shall not require the removal of existing roof coverings.~~
- ~~2. Metal panel, metal shingle and concrete and clay tile roof coverings shall be permitted to be installed over existing wood shake roofs when applied in accordance with Section 706.4.~~
- ~~3. The application of a new protective coating over an existing spray polyurethane foam roofing system shall be permitted without tear off of existing roof coverings.~~
- ~~4. Where the existing roof assembly includes an ice barrier membrane that is adhered to the roof deck, the existing ice barrier membrane shall be permitted to remain in place and covered with an additional layer of ice barrier membrane in accordance with Section 1507 of the *International Building Code*.~~

**[BS] 706.4 705.3 Roof recovering.**

Where the application of a new roof covering over wood shingle or shake roofs creates a combustible concealed space, the entire existing surface shall be covered with gypsum board, mineral fiber, glass fiber or other approved materials securely fastened in place.

**[BS] 706.5 705.4 Reinstallation of materials.**

Existing slate, clay or cement tile shall be permitted for reinstallation, except that damaged, cracked or broken slate or tile shall not be reinstalled. Existing vent flashing, metal edgings, drain outlets, collars and metal counterflashings shall not be reinstalled where rusted, damaged or deteriorated. Aggregate surfacing materials shall not be reinstalled.

**[BS] 706.6 705.5 Flashings.**

Flashings shall be reconstructed in accordance with approved manufacturer's installation instructions. Metal flashing to which bituminous materials are to be adhered shall be primed prior to installation.

**SECTION 707 706  
STRUCTURAL**

**[BS] 707.1 706.1 General.**

Where *alteration* work includes replacement of equipment that is supported by the building or where a reroofing permit is required, the provisions of this section shall apply.

**[BS] 707.2 706.2 Addition or replacement of roofing or replacement of equipment.**

~~Where addition or replacement of roofing or replacement of equipment results in additional dead loads, structural components supporting such reroofing or equipment shall comply with the gravity load requirements of the *International Building Code*.~~

**Exceptions:**

- ~~1. Structural elements where the additional dead load from the roofing or equipment does not increase the force in the element by more than 10 percent.~~
- ~~2. Buildings constructed in accordance with the *International Residential Code* or the conventional lightframe construction methods of the *International Building Code* and where the dead load from the roofing or equipment is not increased by more than 5 percent.~~
- ~~3. Addition of a second layer of roof covering weighing 3 pounds per square foot ( $0.1437 \text{ kN/m}^2$ ) or less over an existing, single layer of roof covering.~~

Any existing gravity load-carrying structural element for which an *alteration* causes an increase in design dead, live or snow load, including snow drift effects, of more than 10 percent shall be replaced or altered as needed to carry the gravity loads required by the *International Building Code* for new structures.

**Exceptions:**

1. Buildings of Group R occupancy with not more than five dwelling or sleeping units used solely for residential purposes where the altered building complies with the conventional light-frame construction methods of the *International Building Code* or the provisions of the *International Residential Code*.
2. Buildings in which the increased dead load is due entirely to the addition of a second layer of roof covering weighing 3 pounds per square foot ( $0.1437 \text{ kN/m}^2$ ) or less over an existing single layer of roof covering.

**[BS] ~~707.3-706.3~~ Additional requirements for reroof permits. Deleted.**

**SECTION 707**  
**ELECTRICAL**

707.1 Health care facilities. In Group I-2 facilities, ambulatory care facilities and outpatient clinics, any altered portion of an existing electrical systems shall be required to meet installation and equipment requirements in NFPA 99.

**SECTION 708**  
**ENERGY CONSERVATION**

## **708.1 Minimum requirements.**

Level 1 *alterations* to *existing buildings* or structures are permitted without requiring the entire building or structure to comply with the energy requirements of the *International Energy Conservation Code* or *International Residential Code*. The *alterations* shall conform to the energy requirements of the *International Energy Conservation Code* or *International Residential Code* as they relate to new construction only.

### **708.1.1 Building envelope.**

Building envelope assemblies that are part of the *alteration* shall comply with Sections R402.1.2 or R402.1.4, Sections R402.2.1 through R402.2.15, R402.3.1, R402.3.2, R402.4.3 and R402.4.6 of the *North Carolina Energy Conservation Code* for Group R occupancies and Section C402 of the *North Carolina Energy Conservation Code* for other occupancies.

**Exceptions:** The following *alterations* to conditioned spaces need not comply with the requirements for new construction:

1. Storm windows installed over existing fenestration.
2. Existing ceiling, wall or floor cavities exposed during construction provided that these cavities are insulated. Roof systems requiring air space for ventilation shall retain the ventilation space required.
3. Construction where the existing roof, wall or floor cavity is not exposed.
4. Roof recover and roof replacement such that the existing building or structure is no less conforming to the provisions of this code than the existing building or structure was prior to the *alteration*.
5. Surface-applied window film installed on existing single pane fenestration assemblies to reduce solar heat gain.
6. Air barriers shall not be required for *roof recover* and roof replacement where the *alterations* or renovations to the building do not include *alterations*, renovations or *repairs* to the remainder of the building envelope.
7. *Alterations* that replace less than 50 percent of the luminaires in a space, provided that such *alterations* do not increase the installed interior lighting power.
8. For other than Group R occupancies, replacement of existing doors that separate *conditioned space* from the exterior shall not require the installation of a vestibule or revolving door, provided, however, that an existing vestibule that separates a *conditioned space* from the exterior shall not be removed.

#### **708.1.1.1 Replacement fenestration.**



Where an entire existing fenestration unit is replaced with a new fenestration product, including frame, sash and glazing, the replacement fenestration unit shall meet the applicable requirements for *U*-factor and SHGC in Table R402.1.2 of the *North Carolina Energy Conservation Code* for Group R occupancies and Table C402.4 of the *North Carolina Energy Conservation Code* for other occupancies.

**Exceptions:**

1. *Alterations* that replace less than 50 percent of entire fenestration units may be replaced with like or better fenestration units to match existing fenestration assemblies.
2. An area-weighted average of the *U*-factor of replacement fenestration products being installed in the building for each fenestration product category listed in Table C402.4 of the *North Carolina Energy Conservation Code* shall be permitted to satisfy the *U*-factor requirements for each fenestration product category listed in Table C402.4 of the *North Carolina Energy Conservation Code*. Individual fenestration products from different product categories listed in Table C402.4 of the *North Carolina Energy Conservation Code* shall not be combined in calculating the area-weighted average *U*-factor.

## **CHAPTER 8 ALTERATIONS—LEVEL 2**

### **SECTION 801 GENERAL**

#### **801.1 Scope.**

Level 2 *alterations* as described in Section ~~504~~603 shall comply with the requirements of this chapter.

**Exception.** Deleted.

#### **801.2 Alteration Level 1 compliance.**

In addition to the requirements of this chapter, all work shall comply with the requirements of Chapter 7.

#### **801.3 Compliance.**

All new construction elements, components, systems, and spaces shall comply with the requirements of the *International Building Code*.

**Exceptions:**

1. Windows may be added without requiring compliance with the light and ventilation requirements of the *International Building Code*.

2. Newly installed electrical equipment shall comply with the requirements of Section ~~808~~ 806.
3. The length of dead-end corridors in newly constructed spaces shall only be required to comply with the provisions of Section ~~805.6~~ 804.7.
4. The minimum ceiling height of the newly created habitable and occupiable spaces and corridors shall be 7 feet (2134 mm).
5. Where provided in below-grade transportation stations, existing and new escalators shall be permitted to have a clear width of less than 32 inches (815 mm).
6. New structural members and connections shall be permitted to comply with alternative design criteria in accordance with Section 302.

## **SECTION 802 SPECIAL USE AND OCCUPANCY**

### **~~802.1 General.~~**

~~Alteration of buildings classified as special use and occupancy as described in the *International Building Code* shall comply with the requirements of Section 801.1 and the scoping provisions of Chapter 1 where applicable.~~

### **~~802.2 Paint shops.~~**

~~Paint shops, not classified as Group H, located in occupancies other than Group F shall be 1-hour separated from the remainder of the building with fire barriers or provided with an automatic fire-extinguishing system.~~

### **~~802.3 Waste and soiled linen collection rooms.~~**

~~Waste and soiled linen collection rooms over 100 square feet (9.29 m<sup>2</sup>) shall be 1-hour separated from the remainder of the building with fire barriers or provided with an automatic fire-extinguishing system.~~

### **~~802.4 Chute termination rooms.~~**

~~Chute termination rooms shall be 1-hour separated from the remainder of the building with fire barriers or provided with an automatic fire-extinguishing system.~~

### **~~802.5 Incinerator rooms.~~**

~~Incinerator rooms shall be 2-hour separated from the remainder of the building with fire barriers and provided with an automatic sprinkler system.~~

### **~~802.6 Group I-2 and I-3.~~**

In Group I-2 and I-3, physical plant maintenance shops, laundries over 100 square feet (9.29 m<sup>2</sup>), and padded cells shall be 1-hour separated from the remainder of the building with fire barriers or provided with an automatic sprinkler system.

## **SECTION 803 802 BUILDING ELEMENTS AND MATERIALS**

### **~~803.1~~ 802.1 Scope.**

The requirements of this section are limited to work areas in which Level 2 alterations are being performed and shall apply beyond the work area where specified.

### **~~803.2~~ 802.2 Vertical openings.**

Existing vertical openings shall comply with the provisions of Sections 803.2.1, 803.2.2 and 803.2.3.

#### **~~803.2.1~~ 802.2.1 Existing vertical openings.**

All existing interior vertical openings connecting two or more floors shall be enclosed with approved assemblies having a fire-resistance rating of not less than 1 hour with approved opening protectives.

#### **Exceptions:**

1. Where vertical opening enclosure is not required by the *International Building Code* or the *International Fire Code*.
2. Interior vertical openings other than stairways may be blocked at the floor and ceiling of the *work area* by installation of not less than 2 inches (51 mm) of solid wood or equivalent construction.
3. The enclosure shall not be required where:
  - 3.1. Connecting the main floor and mezzanines; or
  - 3.2. All of the following conditions are met:
    - 3.2.1. The communicating area has a low hazard occupancy or has a moderate hazard occupancy that is protected throughout by an automatic sprinkler system.
    - 3.2.2. The lowest or next to the lowest level is a street floor.
    - 3.2.3. The entire area is open and unobstructed in a manner such that it may be assumed that a fire in any part of the interconnected spaces will be readily obvious to all of the occupants.

- 3.2.4. Exit capacity is sufficient to provide egress simultaneously for all occupants of all levels by considering all areas to be a single floor area for the determination of required exit capacity.
  - 3.2.5. Each floor level, considered separately, has at least one-half of its individual required exit capacity provided by an exit or exits leading directly out of that level without having to traverse another communicating floor level or be exposed to the smoke or fire spreading from another communicating floor level.
4. In Group A occupancies, a minimum 30-minute enclosure shall be provided to protect all vertical openings not exceeding three stories.
5. In Group B occupancies, a minimum 30-minute enclosure shall be provided to protect all vertical openings not exceeding three stories. This enclosure, or the enclosure specified in Section 803.2.1, shall not be required in the following locations:
  - 5.1. Buildings not exceeding 3,000 square feet (279 m<sup>2</sup>) per floor.
  - 5.2. Buildings protected throughout by an approved automatic fire sprinkler system.
6. In Group E occupancies, the enclosure shall not be required for vertical openings not exceeding three stories when the building is protected throughout by an approved automatic fire sprinkler system.
7. In Group F occupancies, the enclosure shall not be required in the following locations:
  - 7.1. Vertical openings not exceeding three stories.
  - 7.2. Special purpose occupancies where necessary for manufacturing operations and direct access is provided to at least one protected stairway.
  - 7.3. Buildings protected throughout by an approved automatic sprinkler system.
8. In Group H occupancies, the enclosure shall not be required for vertical openings not exceeding three stories where necessary for manufacturing operations and every floor level has direct access to at least two remote enclosed stairways or other approved exits.
9. In Group M occupancies, a minimum 30-minute enclosure shall be provided to protect all vertical openings not exceeding three stories. This enclosure, or the enclosure specified in Section 803.2.1, shall not be required in the following locations:
  - 9.1. Openings connecting only two floor levels.

- 9.2. Occupancies protected throughout by an approved automatic sprinkler system.
10. In Group R-1 occupancies, the enclosure shall not be required for vertical openings not exceeding three stories in the following locations:
- 10.1. Buildings protected throughout by an approved automatic sprinkler system.
- 10.2. Buildings with less than 25 dwelling units or sleeping units where every sleeping room above the second floor is provided with direct access to a fire escape or other approved second exit by means of an approved exterior door or window having a sill height of not greater than 44 inches (1118 mm) and where:
- 10.2.1. Any exit access corridor exceeding 8 feet (2438 mm) in length that serves two means of egress, one of which is an unprotected vertical opening, shall have at least one of the means of egress separated from the vertical opening by a 1-hour fire barrier; and
- 10.2.2. The building is protected throughout by an automatic fire alarm system, installed and supervised in accordance with the *International Building Code*.
11. In Group R-2 occupancies, a minimum 30-minute enclosure shall be provided to protect all vertical openings not exceeding three stories. This enclosure, or the enclosure specified in Section 803.2.1, shall not be required in the following locations:
- 11.1. Vertical openings not exceeding two stories with not more than four dwelling units per floor.
- 11.2. Buildings protected throughout by an approved automatic sprinkler system.
- 11.3. Buildings with not more than four dwelling units per floor where every sleeping room above the second floor is provided with direct access to a fire escape or other approved second exit by means of an approved exterior door or window having a sill height of not greater than 44 inches (1118 mm) and the building is protected throughout by an automatic fire alarm system complying with Section ~~804.4~~803.4
12. One- and two-family dwellings.
13. Group S occupancies where connecting not more than two floor levels or where connecting not more than three floor levels and the structure is equipped throughout with an approved automatic sprinkler system.

14. Group S occupancies where vertical opening protection is not required for open parking garages and ramps.
15. In Group I-3 occupancies the vertical opening protection may be omitted if either of the following conditions is met:
  - 15.1. The building is in compliance with NFPA 101, Chapter 15; or
  - 15.2. The building is equipped throughout with an automatic fire suppression system.
16. Vertical opening enclosure is not required where the vertical opening enclosure meets the code requirements under which the building was constructed or previously altered.

**803.2.2802.2.2 Supplemental shaft and floor opening enclosure requirements.**

Where the *work area* on any floor exceeds 50 percent of that floor area, the enclosure requirements of Section 803.2 shall apply to vertical openings other than stairways throughout the floor.

**Exception:** Vertical openings located in tenant spaces that are entirely outside the *work area*.

**803.2.3802.2.3 Supplemental stairway enclosure requirements.**

Where the *work area* on any floor exceeds 50 percent of that floor area, stairways that are part of the means of egress serving the *work area* shall, at a minimum, be enclosed with smoke-tight construction on the highest *work area* floor and all floors below.

**Exception:** Where stairway enclosure is not required by the *International Building Code* or the *International Fire Code*.

**803.3802.3 Smoke compartments.**

In Group I-2 occupancies where the work area is on a story used for sleeping rooms ~~for more than 30 patients~~, the story shall be divided into not less than two compartments by smoke barrier walls in accordance with Section 407.5 of the *International Building Code* as required for new construction.

**803.4802.4 Interior finish.**

The interior finish of walls and ceilings in exits and corridors in any *work area* shall comply with the requirements of the *International Building Code*.

**Exception:** Existing interior finish materials that do not comply with the interior finish requirements of the *International Building Code* shall be permitted to be treated with an approved fire-retardant coating in accordance with the manufacturer's instructions to achieve the required rating.

**~~803.4.1~~ 802.4.1 Supplemental interior finish requirements.**

Where the *work area* on any floor exceeds 50 percent of the floor area, Section ~~803.4~~ 802.4 shall also apply to the interior finish in exits and corridors serving the *work area* throughout the floor.

**Exception:** Interior finish within tenant spaces that are entirely outside the *work area*.

**~~803.5~~ 802.5 Guards.**

The requirements of Sections ~~803.5.1~~ 802.5.1 and ~~803.5.2~~ 802.5.2 shall apply in all *work areas*.

**~~803.5.1~~ 802.5.1 Minimum requirement.**

Every portion of a floor, such as a balcony or a loading dock, that is more than 30 inches (762 mm) above the floor or grade below and is not provided with guards, or those in which the existing guards are judged to be in danger of collapsing, shall be provided with guards.

**~~803.5.2~~ 802.5.2 Design.**

Where there are no guards or where existing guards must be replaced, the guards shall be designed and installed in accordance with the *International Building Code*.

**~~803.6~~ 802.6 Fire-resistance ratings.**

Where approved by the code official, buildings where an automatic sprinkler system installed in accordance with Section 903.3.1.1 or 903.3.1.2 of the *International Building Code* has been added, and the building is now sprinklered throughout, the required fire-resistance ratings of building elements and materials shall be permitted to meet the requirements of the current building code. The building is required to meet the other applicable requirements of the *International Building Code*.

Plans, investigation and evaluation reports, and other data shall be submitted indicating which building elements and materials the applicant is requesting the code official to review and approve for determination of applying the current building code fire-resistance ratings. Any special construction features, including fire-resistance-rated assemblies and smoke-resistive assemblies, conditions of occupancy, means of egress conditions, fire code deficiencies, approved modifications or approved alternative materials, design and methods of construction, and equipment applying to the building that impact required fire-resistance ratings shall be identified in the evaluation reports submitted.

**802.7 Incidental Uses.** *Alteration* of spaces classified as incidental uses as described in the *International Building Code* shall comply with the requirements of Table 509.1.

**~~803.7~~ 802.8 Fireblocking and draftstopping.**

When the work being performed exposes the framing of any wall, floor, ceiling or roof, the exposed framing shall comply with Section 718 of the *North Carolina Building Code*.

**Exception:** One- and two-family dwellings shall comply with Sections R302.11 and R302.12 of the *North Carolina Residential Code*.

**~~803.8~~ 802.9 Group R mixed-use separation.**

Any nonresidential occupancy that is located directly below Group R shall be 1- hour separated from the Group R occupancy. The 1-hour assembly is only required to be rated from the nonresidential side.

**Exception:** If the work area of the nonresidential occupancy is less than 50 percent of the gross floor area of the nonresidential occupancy, Section **803.8** shall not apply.

**SECTION ~~804~~ 803  
FIRE PROTECTION**

**~~804.1~~ 803.1 Scope.**

The requirements of this section shall be limited to work areas in which Level 2 *alterations* are being performed, and where specified they shall apply throughout the floor on which the *work areas* are located or otherwise beyond the *work area*.

**~~804.1.1~~ 803.1.1 Corridor ratings.**

Where an approved automatic sprinkler system is installed throughout the story, the required fire-resistance rating for any corridor located on the story shall be permitted to be reduced in accordance with the *International Building Code*. In order to be considered for a corridor rating reduction, such system shall provide coverage for the stairway landings serving the floor and the intermediate landings immediately below.

**~~804.2~~ 803.2 Automatic sprinkler systems.**

Automatic sprinkler systems shall be provided in accordance with the requirements of Sections ~~804.2.1~~ 803.2.1 through ~~804.2.6~~. 803.2.6 Installation requirements shall be in accordance with the *International Building Code*.

**~~804.2.2~~ 803.2.1 High-rise and low-rise buildings.**

See Section ~~101.10~~.

**803.2.1.1 High-rise buildings. See Section 101.10**

**~~804.2.1.2~~ 803.2.1.2 Low-rise buildings.**

Work areas that increase the fire area or calculated occupant load above the limits listed in Sections ~~903.2.1~~ through ~~903.2.10~~ of the *North Carolina Building Code* shall meet the requirements of those sections.

**803.2.2 Groups A, B, E, F-1, H, I-1, I-3, I-4, M, R-1, R-2, R-4, S-1 and S-2. Deleted.**

**803.2.3 Group I-2. Deleted.**



### **~~804.2.4~~ ~~803.2.4~~ Windowless stories.**

In all buildings, any windowless story located below the seventh story above grade which is created by the work being performed or any existing windowless story located below the seventh story in which the work area exceeds 50 percent of the gross enclosed floor area of the windowless story, shall be equipped throughout with an automatic fire suppression system installed in accordance with Section 903.2.11.1 of the *North Carolina Fire Code*.

#### **Exceptions:**

1. Stories or basements shall not be considered windowless where fire-fighter access through openings meeting all of the following is provided:
  - 1.1. Openings such as doors, windows, or access panels are located on at least one side of the story or basement;
  - 1.2. The openings on each story or basement shall be a minimum of 32 inches by 48 inches in size and located horizontally a maximum of 100 feet (3048 mm) apart or 22 inches by 42 inches (558 mm by 1066 mm) in size and located horizontally a maximum of 30 feet (9144 mm) apart;
  - 1.3. Openings shall be unobstructed to allow firefighting and rescue operations from the exterior;
  - 1.4. Openings in stories above grade shall have a sill height of not more than 36 inches measured from the finished floor level. Openings in basements shall have no sill height restrictions;
  - 1.5 Openings shall be readily identifiable and openable from the outside; and
  - ~~1.5.~~ ~~1.6~~ Where openings are provided only on one wall of a story or basement the maximum distance to the opposite wall is 75 feet (22 860 mm).
2. Windowless basements 3,000 gross square feet or less in area shall not require automatic fire suppression when a supervised automatic fire alarm is provided in accordance with Section 907 of the *North Carolina Fire Code*.
3. Windowless basements greater than 3,000 but less than 10,000 gross square feet shall be permitted to connect to the domestic water supply when all of the following conditions are met:
  - 3.1. The automatic fire suppression system shall be provided with a fire department connection, which shall be marked with a sign reading "Basement Area Sprinkler Water Supply;" and

3.2. A supervised automatic fire alarm system shall be installed in accordance with Section 907 of the *North Carolina Fire Code*.

**~~804.2.4~~803.2.5 Other required automatic sprinkler systems.** Deleted

**~~804.2.5~~803.2.6 Supervision.**

All newly installed complete or partial sprinkler systems shall comply with Section 903.4 of the *North Carolina Building Code*.

**Exception:** Supervision is not required for the following:

1. Underground gate valve with roadway boxes.
2. Automatic sprinkler systems installed in accordance with NFPA 13R where a common supply main is used to supply both domestic and automatic sprinkler systems and a separate shutoff valve for the automatic sprinkler system is not provided.

**~~804.2.6~~803.2.7 Group H.**

An automatic sprinkler system shall be installed in all Group H occupancies complying with Section 903.2.5 of the *North Carolina Building Code*.

**~~804.3~~803.3 Standpipes.** Deleted.

**~~804.4~~803.4 Fire alarm and detection.**

An approved fire alarm system shall be installed in accordance with Sections ~~804.4.1~~ ~~803.4.1~~ through ~~804.4.3~~ ~~803.4.2~~. Where automatic sprinkler protection is provided in accordance with Section 803.2 and is connected to the building fire alarm system, automatic heat detection shall not be required.

An approved automatic fire detection system shall be installed in accordance with the provisions of this code and NFPA 72. Devices, combinations of devices, appliances, and equipment shall be approved. The automatic fire detectors shall be smoke detectors, except that an approved alternative type of detector shall be installed in spaces such as boiler rooms, where products of combustion are present during normal operation in sufficient quantity to actuate a smoke detector.

**~~804.4.1~~ Fire alarms.**

~~Work areas that do not have an existing fire alarm system are not required to install a fire alarm system. Work areas where new fire alarm systems are installed shall be in accordance with Section 907 of the *North Carolina Building Code*.~~

#### ~~804.4.2 Smoke alarms.~~

~~Individual sleeping units and individual dwelling units in any *work area* in Group R and I-1 occupancies shall be provided with smoke alarms in accordance with Section 907.2.11 of the *North Carolina Building Code*. Smoke alarms for Group R occupancy are permitted to be radio frequency type appliances as allowed and installed by NFPA 72.~~

~~**Exception:** Interconnection of smoke alarms outside of the *work area* shall not be required.~~

#### ~~804.4.2.1 Smoke detection Group R mixed use.~~

~~Any nonresidential occupancy work area located directly below Group R shall be provided with single or multi-station smoke detectors complying with NFPA 72 and shall provide an audible alarm in each dwelling unit located on floors above the nonresidential work area. The detectors shall be AC powered with battery backup.~~

#### ~~Exceptions:~~

- ~~1. Hardwired, interconnected smoke detectors installed throughout the building shall be accepted as complying with Section 804.4.2.1.~~
- ~~2. The work area of the nonresidential occupancy is less than 50 percent of the gross floor area of the nonresidential occupancy.~~

#### ~~804.4.2.2 Smoke alarms in one- and two-family dwellings and townhouses.~~

~~Detached one- and two-family dwellings and townhouses shall be provided with smoke alarms installed in accordance with Section R314 of the *North Carolina Residential Code*.~~

#### ~~804.4.3 Carbon monoxide alarms.~~

~~Individual sleeping units and individual dwelling units in Group R and I occupancies and classrooms in Group E occupancies shall be provided with carbon monoxide alarms in accordance with Section 915 of the *North Carolina Building Code*, except that the carbon monoxide alarms shall be allowed to be solely battery operated.~~

#### ~~804.4.3.1 Carbon monoxide alarms in one- and two-family dwellings and townhouses.~~

~~Detached one- and two-family dwellings and townhouses shall be provided with carbon monoxide alarms installed in accordance with Section R315 of the *North Carolina Residential Code*.~~

803.4.1 Occupancy requirements. A fire alarm system shall be installed in accordance with Sections 803.4.1.1 through 803.4.1.6. Existing alarm-notification appliances shall be automatically activated throughout the building. Where the building is not equipped with a fire alarm system, alarm-notification appliances within the *work area* shall be provided and automatically activated.

**Exceptions:**

1. Occupancies with an existing, previously *approved* fire alarm system.
2. Where selective notification is permitted, alarm-notification appliances shall be automatically activated in the areas selected.

**803.4.1.1 Group E.** A fire alarm system shall be installed in *work areas* of Group E occupancies as required by the *International Building Code* for existing Group E occupancies.

**803.4.1.2 Group I-1.** An automatic fire alarm system shall be installed in *work areas* of Group I-1 *facilities* as required by Chapter 9 of the *International Building Code* for existing Group I-1 occupancies.

**803.4.1.3 Group I-2.** An automatic fire alarm system shall be installed throughout Group I-2 occupancies as required by Chapter 9 of the *International Building Code*.

**803.4.1.4 Group I-3.** A fire alarm system shall be installed in *work areas* of Group I-3 occupancies as required by the *International Building Code*.

**803.4.1.5 Group R-1.** A fire alarm system shall be installed in Group R-1 occupancies as required by the *International Building Code* for existing Group R-1 occupancies.

**803.4.1.6 Group R-2.** A fire alarm system shall be installed in *work areas* of Group R-2 apartment buildings as required by the *International Building Code* for existing Group R-2 occupancies.

**803.4.2 Supplemental fire alarm system requirements.** Where the *work area* on any floor exceeds 50 percent of that floor area, Section 803.4.1 shall apply throughout the floor.

**Exception:** Alarm-initiating and notification appliances shall not be required to be installed in tenant spaces outside of the *work area*. \*

## SECTION 805 804 MEANS OF EGRESS

### **805.1 804.1 Scope.**

The requirements of this section shall be limited to work areas that include exits or corridors shared by more than one tenant within the *work area* in which Level 2 *alterations* are being performed, and where specified they shall apply throughout the floor on which the *work areas* are located or otherwise beyond the *work area*.

### **805.2 804.2 General.**

The means of egress shall comply with the requirements of this section.

**Exceptions:**

1. Where the *work area* and the means of egress serving it complies with NFPA 101.
2. Means of egress conforming to the requirements of the building code under which the building was constructed shall be considered compliant means of egress if, in the opinion of the *code official*, they do not constitute a distinct hazard to life.

3. In one- and two-family dwellings, stairways not required for egress shall be permitted to be a minimum width of 26 inches.

**~~805.2.1~~ 804.2.1 Means of egress capacity.**

The capacity of the means of egress in each work area shall be sufficient for the maximum permitted occupant load of the work area and any adjacent spaces served by that means of egress as calculated on a per floor basis. Means of egress shall be measured in units of exit width of 22 inches. The maximum permitted occupant load of a space shall be determined by the capacity of the means of egress serving the space as calculated in accordance with ~~Table 805.2.1~~ 804.2.1. The building owner shall have the option of establishing a reasonable restriction on the occupant load of the space based on the existing capacity of the means of egress or of providing additional egress capacity.

**TABLE ~~805.2.1~~ 804.2.1<sup>a,b</sup>  
CAPACITY PER UNIT OF EGRESS WIDTH**

| Use Group      | Number of Occupants      |                             |                       |                             |
|----------------|--------------------------|-----------------------------|-----------------------|-----------------------------|
|                | Without Fire Suppression |                             | With Fire Suppression |                             |
|                | Stairways                | Doors, Ramps, and Corridors | Stairways             | Doors, Ramps, and Corridors |
| A <sup>c</sup> | 75                       | 100                         | 113                   | 150                         |
| B              | 60                       | 100                         | 90                    | 150                         |
| E              | 75                       | 100                         | 113                   | 150                         |
| F              | 60                       | 100                         | 90                    | 150                         |
| H              | NA                       | NA                          | 60                    | 100                         |
| I-1            | 60                       | 100                         | 90                    | 100                         |
| I-2            | 22                       | 30                          | 35                    | 45                          |
| I-3            | 60                       | 100                         | 90                    | 150                         |
| M              | 60                       | 100                         | 90                    | 150                         |
| R              | 75                       | 100                         | 113                   | 150                         |
| S              | 60                       | 100                         | 90                    | 150                         |

Unit of egress width = 22 inches

NA = Not Allowed

- a. The occupant load may be equal to the total number of occupants for which exit capacity is provided as determined by ~~Table 805.2.1~~ 804.2.1 above.
- b. Interpolation shall be allowed in determining capacity of egress width.
- c. For Use Group A occupancies, the resulting total occupant load shall not exceed one occupant per five square feet of net floor area over the entire use.

**804.3 Group I-2.** In Group I-2 occupancies, in areas where corridors are used for movement of care recipients in beds, the clear width of ramps and corridors shall be not less than 48 inches (1219 mm).

**~~805.3~~ 804.4 Number of exits.**

The number of exits shall be in accordance with Sections 805.3.1 through 805.3.3.

**805.3.1 804.4 .1 Minimum number.**

Every story utilized for human occupancy on which there is a *work area* that includes exits or corridors shared by more than one tenant within the *work area* shall be provided with the minimum number of exits based on the occupancy and the occupant load in accordance with the *International Building Code*. In addition, the exits shall comply with Sections 805.3.1.4 804.4.1.1 and 805.3.1.2 804.4.1.2.

**805.3.1.1804.4.1.1 Single-exit buildings.**

Only one exit is required from buildings and spaces of the following occupancies:

- ~~1. In Group A, B, E, F, M, U and S occupancies, a single exit is permitted in the story at the level of exit discharge when the occupant load of the story does not exceed 49 and the exit access travel distance does not exceed 75 feet (22 860 mm).~~

~~**Exception:** Licensed Group E adult and child day care occupancies shall have a minimum of two exits. Rooms where occupants receive care are on the level of exit discharge and each of these rooms has an exit door directly to the exterior may have a single exit.~~

- ~~2. Group B, F-2, and S-2 occupancies not more than two stories in height that are not greater than 3,500 square feet per floor (326 m<sup>2</sup>), when the exit access travel distance does not exceed 75 feet (22 860 mm). The minimum fire resistance rating of the exit enclosure and of the opening protection shall be 1 hour.~~
- ~~3. Open parking structures where vehicles are mechanically parked.~~
- ~~4. In Group R-4 occupancies, the maximum occupant load excluding staff is 16.~~
- ~~5. Groups R-1 and R-2 not more than two stories in height, when there are not more than four dwelling units per floor and the exit access travel distance does not exceed 50 feet (15 240 mm). The minimum fire resistance rating of the exit enclosure and of the opening protection shall be 1 hour.~~
- ~~6. In multilevel dwelling units in buildings of occupancy Group R-1 or R-2, an exit shall not be required from every level of the dwelling unit provided that one of the following conditions is met:
  - ~~6.1. The travel distance within the dwelling unit does not exceed 75 feet (22 860 mm); or~~
  - ~~6.2. The building is not more than three stories in height and all third-floor space is part of one or more dwelling units located in part on the second floor; and no habitable room within any such dwelling unit shall have a travel distance that exceeds 50 feet (15 240 mm) from the outside of the habitable room entrance door to the inside of the entrance door to the dwelling unit.~~~~

- ~~7. In Group R-2, H-4, H-5 and I occupancies and in rooming houses and child care centers, a single exit is permitted in a one-story building with a maximum occupant load of 10 and the exit access travel distance does not exceed 75 feet (22 860 mm).~~
- ~~8. In buildings of Group R-2 occupancy that are equipped throughout with an automatic fire sprinkler system, a single exit shall be permitted from a basement or story below grade if every dwelling unit on that floor is equipped with an approved window providing a clear opening of at least 5 square feet (0.47 m<sup>2</sup>) in area, a minimum net clear opening of 24 inches (610 mm) in height and 20 inches (508 mm) in width, and a sill height of not more than 44 inches (1118 mm) above the finished floor.~~
- ~~9. In buildings of Group R-2 occupancy of any height with not more than four dwelling units per floor; with a smokeproof enclosure or outside stairway as an exit; and with such exit located within 20 feet (6096 mm) of travel to the entrance doors to all dwelling units served thereby.~~
- ~~10. In buildings of Group R-3 occupancy equipped throughout with an automatic fire sprinkler system, only one exit shall be required from basements or stories below grade.~~
- ~~11. Licensed Group R-4 adult and child day care rooms where occupants receive care and that meet all of the following shall have a minimum of one means of egress:
 
  - ~~11.1. Located on the level of exit discharge, and~~
  - ~~11.2. The egress door discharges directly to the exterior.~~~~

A single exit or access to a single exit shall be permitted from spaces, any story or any occupied roof where one of the following conditions exists:

1. The occupant load, number of dwelling units and exit access travel distance do not exceed the values in Table 804.4.1.1(1) or Table 804.4.1.1(2).
2. In Group R-1 or R-2, buildings without an *approved* automatic sprinkler system, individual single-story or multiple-story dwelling or sleeping units shall be permitted to have a single exit or access to a single exit from the dwelling or sleeping unit provided one of the following criteria are met:
 
  - 2.1. The occupant load is not greater than 10 and the exit access travel distance within the unit does not exceed 75 feet (22 860 mm).
  - 2.2. The building is not more than three stories in height; all third-story space is part of dwelling with an exit access doorway on the second story; and the portion of the exit access travel distance from the door to any habitable room within any such unit to the unit entrance doors does not exceed 50 feet (15 240 mm).
3. In buildings of Group R-2 occupancy of any number of stories with not more than four dwelling units per floor served by an interior exit stairway; with a smokeproof enclosure in accordance with Sections 909.20 and 1023.12 of the *International Building Code* or an exterior stairway as an exit; and where the portion of the exit access travel distance from the dwelling unit entrance door to the exit is not greater than 20 feet (6096 mm).

**TABLE 804.4.1.1(1)**

**STORIES WITH ONE EXIT OR ACCESS TO ONE EXIT FOR R-2 OCCUPANCIES**

| <u>STORY</u>   | <u>OCCUPAN<br/>CY</u>  | <u>MAXIMU<br/>M<br/>NUMBER<br/>OF<br/>DWELLING<br/>UNITS</u> | <u>MAXIMU<br/>M EXIT<br/>ACCESS<br/>TRAVEL<br/>DISTANCE<br/>(feet)</u> |
|--|------------------------|--|--|
| <u>Basement, first<br/>or second story<br/>above grade<br/>plane</u> | <u>R-2<sup>a</sup></u> | <u>4 dwelling<br/>units</u>                                  | <u>50</u>  |
| <u>Third story<br/>above grade<br/>plane and higher</u>              | <u>NP</u>              | <u>NA</u>  | <u>NA</u>  |

For SI: 1 foot = 304.8 mm.

NP = Not Permitted.

NA = Not Applicable.

a. Group R-2, without an approved automatic sprinkler system and provided with emergency escape and rescue openings in accordance with Section 1031 of the *International Building Code*.

**TABLE 804.4.1.1(2)**

**STORIES WITH ONE EXIT OR ACCESS TO ONE EXIT FOR OTHER OCCUPANCIES**

| <u>STORY</u>  | <u>OCCUPAN<br/>CY</u>          | <u>MAXIMU<br/>M<br/>OCCUPA<br/>NT LOAD<br/>PER<br/>STORY</u> | <u>MAXIMU<br/>M EXIT<br/>ACCESS<br/>TRAVEL<br/>DISTANCE<br/>(feet)</u> |
|---|--------------------------------|--|--|
| <u>First story above<br/>or below grade<br/>plane</u>   | <u>B, F-2, S-2<sup>a</sup></u> | <u>35</u>  | <u>75</u>  |
| <u>Second story<br/>above grade<br/>plane</u>           | <u>B, F-2, S-2<sup>a</sup></u> | <u>35</u>  | <u>75</u>  |
| <u>Third story above<br/>grade plane and<br/>higher</u> | <u>NP</u>                      | <u>NA</u>  | <u>NA</u>  |

For SI: 1 foot = 304.8 mm.

NP = Not Permitted.

NA = Not Applicable.



a. The length of exit access travel distance in a Group S-2 open parking garage shall be not more than 100 feet.

**805.3.1.2 804.4.1.2 Fire escapes required.**

For other than Group I-2, where more than one exit is required, an existing or newly constructed fire escape complying with Section 805.3.1.2.1 shall be accepted as providing one of the required means of egress.

**805.3.1.2.1 804.4.1.2.1 Fire escape access and details.**

Fire escapes shall comply with all of the following requirements:

1. Occupants shall have unobstructed access to the fire escape without having to pass through a room subject to locking.
2. Access to a new fire escape shall be through a door, except that windows shall be permitted to provide access from single dwelling units or sleeping units in Group R-1, R-2 and I-1 occupancies or to provide access from spaces having a maximum occupant load of 10 in other occupancy classifications.
  - 2.1. The window shall have a minimum net clear opening of 5.7 square feet (0.53 m<sup>2</sup>) or 5 square feet (0.46 m<sup>2</sup>) where located at grade.
  - 2.2. The minimum net clear opening height shall be 24 inches (610 mm) and net clear opening width shall be 20 inches (508 mm).
  - 2.3. The bottom of the clear opening shall not be greater than 44 inches (1118 mm) above the floor.
  - 2.4. The operation of the window shall comply with the operational constraints of the *International Building Code*.
3. Newly constructed fire escapes shall be permitted only where exterior stairways cannot be utilized because of lot lines limiting the stairway size or because of the sidewalks, alleys, or roads at grade level.
4. Openings within 10 feet (3048 mm) of fire escape stairways shall be protected by fire assemblies having minimum  $\frac{3}{4}$ -hour fire-resistance ratings.

**Exception:** Opening protection shall not be required in buildings equipped throughout with an approved automatic sprinkler system.

5. In all buildings of Group E occupancy, up to and including the 12th grade, buildings of Group I occupancy, boarding houses and childcare centers, ladders of any type are prohibited on fire escapes used as a required means of egress.

**~~805.3.1.2.2~~ 804.4.1.2.2 Construction.**

The fire escape shall be designed to support a live load of 100 pounds per square foot (4788 Pa) and shall be constructed of steel or other approved *noncombustible materials*. Fire escapes constructed of wood not less than nominal 2 inches (51 mm) thick are permitted on buildings of Type V construction. Walkways and railings located over or supported by combustible roofs in buildings of Types III and IV construction are permitted to be of wood not less than nominal 2 inches (51 mm) thick.

**~~805.3.1.2.3~~ 804.4.2.3 Dimensions.**

Stairways shall be at least 22 inches (559 mm) wide with risers not more than, and treads not less than, 8 inches (203 mm). Landings at the foot of stairways shall be not less than 40 inches (1016 mm) wide by 36 inches (914 mm) long and located not more than 8 inches (203 mm) below the door.

**~~805.3.2~~ 804.4.2 Mezzanines.**

Mezzanines in the *work area* and with an occupant load of more than 49 or in which the travel distance to an exit exceeds 75 feet (22 860 mm) shall have access to at least two independent means of egress.

**Exception:** Two independent means of egress are not required where the travel distance to an exit does not exceed 100 feet (30 480 mm) and the building is protected throughout with an automatic sprinkler system.

**~~805.3.3~~ 804.4.3 Main entrance—Group A.**

Where the main entrance is included in the alteration, buildings of Group A with an occupant load of 300 or more shall be provided with a main entrance capable of serving as the main exit with an egress capacity of at least one-half of the total occupant load. The remaining exits shall be capable of providing one-half of the total required exit capacity.

**Exception:** Where there is no well-defined main exit or where multiple main exits are provided, exits shall be permitted to be distributed around the perimeter of the building provided that the total width of egress is not less than 100 percent of the required width.

**~~805.4~~ 804.5 Egress doorways.**

Egress doorways in any *work area* shall comply with Sections ~~805.4.4~~ 804.5.1 through ~~805.4.5~~ 804.5.5

**~~805.4.1~~ 804.5.1 Two egress doorways required.**

Work areas shall be provided with two egress doorways in accordance with the requirements of Sections ~~805.4.1.1~~ 804.5.1.1 and ~~805.4.1.3~~ 804.5.1.3

**~~805.4.1.1~~ 804.5.1.1 Occupant load and travel distance.**

In any *work area*, all rooms and spaces having an occupant load of 50 or more or in which the travel distance to an exit exceeds 75 feet (22 860 mm) shall have a minimum of two egress doorways.

**Exceptions:**

1. Storage rooms having a maximum occupant load of 10.
2. Where the *work area* is served by a single exit in accordance with Section ~~805.3.1.1~~ 804.4.1.1
3. The occupant load of the space may be restricted to comply with Section 1006 of the *North Carolina Building Code*. Signage indicating the allowed quantity of occupants shall be permanently mounted in the building at a location approved by the local fire marshal.

**~~805.4.1.2~~ 804.5.1.2 Group I-2.**

In buildings of Group I-2 occupancy, any patient sleeping room or suite of patient rooms greater than 1,000 square feet (93 m<sup>2</sup>) within the *work area* shall have a minimum of two egress doorways.

In Group I-2, Condition 2 work areas that include altered care suites shall comply with Sections 407.4.4 through 407.4.4.6.2 of the International Building Code. Remote locking shall comply with Section 407.11 of the North Carolina Building Code.

**~~805.4.1.3~~ 805.4.1.3 Group E licensed adult and child day care.**

Group E and R-4 adult and child day care facilities shall have two means of egress. Rooms where occupants receive care and that meet all of the following shall have a minimum of one means of egress:

1. Located on the level of exit discharge, and
2. The egress door discharges directly to the exterior.

**~~805.4.2~~ 804.5.2 Door swing.**

In the *work area* and in the egress path from any *work area* to the exit discharge, all egress doors serving an occupant load greater than 50 shall swing in the direction of exit travel.

**~~805.4.2.1~~ 804.5.2.1 Supplemental requirements for door swing.**

Where the *work area* exceeds 50 percent of the floor area, door swing shall comply with Section ~~805.4.2~~ 804.5.2 throughout the floor.

**Exception:** Means of egress within or serving only a tenant space that is entirely outside the *work area*.

**~~805.4.3~~ 804.5.3 Door closing.**

In any *work area*, all doors opening onto an exit passageway at grade or an exit stairway shall be self-closing or automatic-closing by listed closing devices.

**Exceptions:**

1. Where exit enclosure is not required by the *International Building Code*.
2. Means of egress within or serving only a tenant space that is entirely outside the *work area*.

**~~805.4.3.1~~ 804.5.2.1 Supplemental requirements for door closing.**

Where the *work area* exceeds 50 percent of the floor area, doors shall comply with Section ~~805.4.3~~ 804.5.3 throughout the exit stairway from the *work area* to, and including, the level of exit discharge.

~~Exception:~~ Means of egress within or serving only a tenant space that is entirely outside the *work area*.

**~~805.4.4~~ 804.5.4 Panic hardware and fire exit hardware.**

In any *work area*, and in the egress path from any *work area* to the exit discharge, in buildings or portions thereof of Group A assembly occupancies with an occupant load greater than 100, all required exit doors equipped with latching devices shall be equipped with approved panic hardware. panic or fire exit hardware in accordance with Section 1010.2.9 of the *International Building Code*.

**~~805.4.4.1~~ 804.5.4.1 Supplemental requirements for panic hardware. Deleted.**

**~~805.4.5~~ 804.5.5 Emergency power source in Groups ~~I-2 and I-3~~.**

Power operated sliding doors or power-operated locks for swinging doors shall be operable by a manual release mechanism at the door. Emergency power shall be provided for the doors and locks in accordance with Section 2702 of the *International Building Code*.

**Exceptions:**

1. Emergency power is not required in facilities with 10 or fewer locks complying with the exception to Section 408.4.1 of the *International Building Code*.
2. Emergency power is not required where remote mechanical operating releases are provided.

**~~805.4.6~~ Group I-2 locks and latches.**

~~Remote locking shall comply with Section 407.11 of the *North Carolina Building Code*.~~

**~~805.5~~ 804.6 Openings in corridor walls.**

Openings in corridor walls in any *work area* shall comply with Sections ~~805.5.1~~ 804.6.1 through ~~805.5.4~~ 804.6.4.

**Exception:** Openings in corridors where such corridors are not required to be rated in accordance with the *International Building Code*.

**805.5.1 804.6.1 Corridor doors.**

Corridor doors in the *work area* shall not be constructed of hollow core wood and shall not contain louvers. All dwelling unit or sleeping unit corridor doors in work areas in buildings of Groups R-1, R-2, and I-1 shall be at least  $1\frac{3}{8}$ -inch (35 mm) solid core wood or approved equivalent and shall not have any glass panels, other than approved wired glass or other approved glazing material in metal frames. All dwelling unit or sleeping unit corridor doors in *work areas* in buildings of Groups R-1, R-2, and I-1 shall be equipped with approved door closers. All replacement doors shall be  $1\frac{3}{4}$ -inch (44 mm) solid bonded wood core or approved equivalent, unless the existing frame will accommodate only a  $1\frac{3}{8}$ -inch (35 mm) door.

**Exceptions:**

1. Corridor doors within a dwelling unit or sleeping unit.
2. Existing doors meeting the requirements of *Guidelines on Fire Ratings of Archaic Materials and Assemblies* (IEBC Resource A) for a rating of 15 minutes or more shall be accepted as meeting the provisions of this requirement.
3. Existing doors in buildings protected throughout with an approved automatic sprinkler system shall be required only to resist smoke, be reasonably tight fitting, and shall not contain louvers.
4. In group homes with a maximum of 15 occupants and that are protected with an approved automatic detection system, closing devices may be omitted.
5. Door assemblies having a fire protection rating of at least 20 minutes.

**805.5.2 804.6.2 Transoms.**

In all buildings of Group I-1, I-2, R-1 and R-2 occupancies, all transoms in corridor walls in work areas shall be either glazed with  $\frac{1}{4}$ -inch (6.4 mm) wired glass set in metal frames or other glazing assemblies having a fire protection rating as required for the door and permanently secured in the closed position or sealed with materials consistent with the corridor construction.

**805.5.3 804.6.3 Other corridor openings.**

In any *work area*, any other sash, grille, or opening in a corridor and any window in a corridor not opening to the outside air shall be sealed with materials consistent with the corridor construction.

**805.5.3.1 804.6.4 Supplemental requirements for other corridor opening.**

Where the *work area* exceeds 50 percent of the floor area, Section 805.5.3 shall be applicable to all corridor windows, grills, sashes, and other openings on the floor.

**Exception:** Means of egress within or serving only a tenant space that is entirely outside the *work area*.

**805.5.4 804.6.4 Supplemental requirements for corridor openings.**

Where the *work area* on any floor exceeds 50 percent of the floor area, ~~the requirements of Sections 805.5.4 804.6.3 through 805.5.3~~ Section 804.6.3 shall be applicable to all corridor windows, grills, sashes and other openings on apply throughout the floor.

**805.6 804.7 Dead-end corridors.**

Dead-end corridors in any *work area* shall not exceed 35 feet (10 670 mm). In Group I-2 occupancies, dead-end corridors shall not exceed 30 feet (9144 mm).

**Exceptions:**

1. Where dead-end corridors of greater length are permitted by the *International Building Code*.
2. In other than Group A, I-2 , and H occupancies, the maximum length of an existing dead-end corridor shall be 50 feet (15 240 mm) in buildings equipped throughout with an automatic fire alarm system installed in accordance with the *International Building Code*.
3. In other than Group A, I-2, and H occupancies, the maximum length of an existing dead-end corridor shall be 70 feet (21 356 mm) in buildings equipped throughout with an automatic sprinkler system installed in accordance with the *International Building Code*.
4. Deleted.

**805.7 804.8 Means-of-egress lighting.**

Means-of-egress lighting shall be in accordance with this section, as applicable.

**805.7.1 804.8.1 Artificial lighting required.**

Means of egress in all work areas shall be provided with artificial lighting in accordance with the requirements of the *International Building Code*.

**805.7.2 804.8.2 Supplemental requirements for means-of egress lighting.**

Where the *work area* on any floor exceeds 50 percent of that floor area, means of egress throughout the floor shall comply with Section ~~805.7.1~~ 804.8.1.

**Exception:** Means of egress within or serving only a tenant space that is entirely outside the *work area*.

**~~805.8~~ 804.9 Exit signs.**

Exit signs shall be in accordance with this section, as applicable.

**~~805.8.1~~ 804.9.1 Work areas.**

Means of egress in all work areas shall be provided with exit signs in accordance with the requirements of the *International Building Code*.

**~~805.8.2~~ 804.9.2 Supplemental requirements for exit signs.**

Where the *work area* on any floor exceeds 50 percent of that floor area, means of egress throughout the floor shall comply with Section ~~805.8.1~~ 804.9.1.

**Exception:** Means of egress within a tenant space that is entirely outside the *work area*.

**~~805.9~~ 804.10 Handrails.**

The requirements of Sections ~~805.9.1~~ 804.10.1 and ~~805.9.2~~ 804.10.2 shall apply to handrails from the *work area* floor to, and including, the level of exit discharge.

**~~805.9.1~~ 804.10.1 Minimum requirement.**

Every required exit stairway that is part of the means of egress for any *work area* and that has three or more risers and is not provided with at least one handrail, or in which the existing handrails are judged to be in danger of collapsing, shall be provided with handrails for the full length of the stairway on at least one side. All exit stairways with a required egress width of more than 66 inches (1676 mm) shall have handrails on both sides.

**~~805.9.2~~ 804.10.2 Design.**

Handrails required in accordance with Section ~~805.9.1~~ 804.10.1 shall be designed and installed in accordance with the provisions of the *International Building Code*.

**~~805.10~~ 804.11 Refuge areas.**

Where alterations affect the configuration of an area utilized as a refuge area, the capacity of the refuge area shall not be reduced below that required ~~in Sections 805.10.1 and 805.10.2.~~ capacity of the refuge area for horizontal exits in accordance with Section 1026.4 of the *International Building Code*. Where the horizontal exit also forms a smoke compartment, the capacity of the refuge area for Group I-1, I-2 and I-3 occupancies and Group B ambulatory care facilities shall not be reduced below that required in Sections 407.5.3, 408.6.2, 420.6.1 and 422.3.2 of the *International Building Code*, as applicable.

**~~805.10.1~~ Capacity.**

~~The required capacity of refuge areas shall be in accordance with Sections 805.10.1.1 through 805.10.1.3.~~

#### **805.10.1.1 Group I-2.**

In Group I-2 occupancies, the required capacity of the refuge areas for smoke compartments in accordance with Section 407.5.1 of the *International Building Code* shall be maintained.

#### **805.10.1.2 Group I-3.**

In Group I-3 occupancies, the required capacity of the refuge areas for smoke compartments in accordance with Section 408.6.2 of the *International Building Code* shall be maintained.

#### **805.10.1.3 Ambulatory care.**

In ambulatory care facilities required to be separated by Section 422.2 of the *International Building Code*, the required capacity of the refuge areas for smoke compartments in accordance with Section 422.4 of the *International Building Code* shall be maintained.

#### **805.10.2 Horizontal exits.**

The required capacity of the refuge area for horizontal exits in accordance with Section 1026.4 of the *International Building Code* shall be maintained.

#### **805.11 804.12 Guards.**

The requirements of Sections 805.11.1 804.12.1 and 805.11.2 804.12.2 shall apply to guards from the *work area* floor to, and including, the level of exit discharge but shall be confined to the egress path of any *work area*.

#### **805.11.1 804.12.1 Minimum requirement.**

Every open portion of a stairway, landing, or balcony that is more than 30 inches (762 mm) above the floor or grade below and is not provided with guards, or those portions in which existing guards are judged to be in danger of collapsing, shall be provided with guards.

#### **805.11.2 804.12.2 Design.**

Guards required in accordance with Section 805.11.1 804.12.1 shall be designed and installed in accordance with the *International Building Code*.

#### **805.12 804.13 Emergency escape and rescue openings.**

When the work being performed creates a classroom in a Group E occupancy or a bedroom below the fourth floor in a Group R occupancy, at least one sleeping room window or exterior door shall comply with Sections 805.12.1 through 805.12.3. Section 1031 of the *North Carolina Building Code*.

**Exception:** Emergency escape and rescue openings are not required to comply with this section where the sleeping room is provided with a door to a corridor having access to two remote exits or in a building equipped throughout with an automatic fire suppression system.

#### **805.12.1 Operation.**

Emergency escape and rescue openings shall be operational from the inside without the use of keys or tools.



### **~~805.12.2 Sill height.~~**

~~The opening shall have a sill height not greater than 44 inches (1117 mm) measured from the floor.~~

### **~~805.12.3 Minimum size.~~**

~~The minimum net clear opening shall be 5.7 square feet (0.529 m<sup>2</sup>). The minimum net clear opening width shall be 20 inches (508 mm). The minimum net clear opening height shall be 24 inches (609 mm). The clear opening dimensions shall be the result of normal operation of the opening.~~

## **SECTION 806 ACCESSIBILITY**

### **806.1 General.**

~~A facility that is altered shall comply with the applicable provisions in Sections 806.1.1 through 806.1.13, and Chapter 11 of the *International Building Code* unless it is *technically infeasible*. Where compliance with this section is *technically infeasible*, the alteration shall provide access to the maximum extent that is technically feasible.~~

~~A facility that is constructed or altered to be accessible shall be maintained accessible during occupancy.~~

#### **Exceptions:**

- ~~1. The altered element or space is not required to be on an accessible route unless required by Section 806.2.~~
- ~~2. Accessible means of egress required by Chapter 10 of the *International Building Code* are not required to be provided in existing facilities.~~
- ~~3. Type B dwelling or sleeping units required by Section 1107 of the *International Building Code* are not required to be provided in existing facilities undergoing less than a Level 3 alteration.~~
- ~~4. The alteration to Type A individually owned dwelling units within a Group R-2 occupancy shall meet the provisions for Type B dwelling units.~~

#### **806.1.1 Entrances.**

~~Where an alteration includes alterations to an entrance, and the facility has an accessible entrance on an accessible route, the altered entrance is not required to be accessible unless required by Section 806.2. Signs complying with Section 1111 of the *International Building Code* shall be provided.~~

#### **806.1.2 Elevators.**

~~Altered elements of existing elevators shall comply with ASME A17.1/CSA B44 and ICC A117.1. Such~~  
2018 2024 North Carolina Existing Building Code

elements shall also be altered in elevators programmed to respond to the same hall call control as the altered elevator.

**806.1.3 Platform lifts.**

Platform (wheelchair) lifts complying with ICC A117.1 and installed in accordance with ASME A18.1 shall be permitted as a component of an accessible route.

**806.1.3.1 Inclined stairway chairlifts.**

Inclined stairway chairlifts that do not reduce the required means of egress and installed in accordance with ASME A18.1 shall be permitted as a component of an accessible route in alterations of existing occupancies in:

- 3. ~~Religious organizations or entities controlled by religious organizations, including places of worship; or~~
- 4. ~~Private clubs or establishments exempted under Title II of the Civil Rights Act of 1964.~~

Such inclined stairway chairlifts shall be approved for commercial use by the manufacturer and installed by approved factory-trained installers.

**806.1.4 Ramps.**

Where steeper slopes than allowed by Section 1012.2 of the *International Building Code* are necessitated by space limitations, the slope of ramps in or providing access to existing facilities shall comply with Table 806.1.4.

**TABLE 806.1.4  
RAMPS**

| <b>SLOPE</b>                                | <b>MAXIMUM<br/>RISE</b> |
|---|-------------------------|
| Steeper than 1:10 but not steeper than 1:8  | 3 inches                |
| Steeper than 1:12 but not steeper than 1:10 | 6 inches                |

For SI: 1 inch = 25.4 mm.

**806.1.5 Dining areas.**

An accessible route to raised or sunken dining areas or to outdoor seating areas is not required provided that the same services and decor are provided in an accessible space usable by any occupant and not restricted to use by people with a disability.

**806.1.6 Jury boxes and witness stands.**

In *alterations*, accessible wheelchair spaces are not required to be located within the defined area of raised

jury boxes or witness stands and shall be permitted to be located outside these spaces where ramp or lift access poses a hazard by restricting or projecting into a required means of egress.

#### **806.1.7 Accessible dwelling or sleeping units.**

Where Group I-1, I-2, I-3, R-1, R-2 or R-4 dwelling or sleeping units are being altered, the requirements of Section 1107 of the *International Building Code* for Accessible units apply only to the quantity of the spaces being altered.

#### **806.1.8 Type A dwelling or sleeping units.**

Where 11 or more Group R-2 dwelling or sleeping units are being altered, the requirements of Section 1107 of the *International Building Code* for Type A units and Chapter 9 of the *International Building Code* for visible alarms apply only to the quantity of the spaces being altered.

#### **806.1.9 Toilet rooms.**

Where it is technically infeasible to alter existing toilet and bathing rooms to be accessible, an accessible family or assisted-use toilet or bathing room constructed in accordance with Section 1109.2.1 of the *International Building Code* is permitted. The family or assisted-use toilet or bathing room shall be located on the same floor and in the same area as the existing toilet or bathing rooms. At the inaccessible toilet and bathing rooms, directional signs indicating the location of the nearest family or assisted-use toilet room or bathing room shall be provided. These directional signs shall include the International Symbol of Accessibility and sign characters shall meet the visual character requirements in accordance with ICG A117.1.

#### **806.1.10 Dressing, fitting and locker rooms.**

Where it is *technically infeasible* to provide accessible dressing, fitting, or locker rooms at the same location as similar types of rooms, one accessible room on the same level shall be provided. Where separate sex facilities are provided, accessible rooms for each sex shall be provided. Separate sex facilities are not required where only unisex rooms are provided.

#### **806.1.11 Fuel dispensers.**

Operable parts of replacement fuel dispensers shall be permitted to be 54 inches (1370 mm) maximum measured from the surface of the vehicular way where fuel dispensers are installed on existing curbs.

#### **806.1.12 Thresholds.**

The maximum height of thresholds at doorways shall be  $\frac{3}{4}$  inch (19.1 mm). Such thresholds shall have beveled edges on each side.

#### **806.1.13 Extent of application.**

An *alteration* of an existing element, space, or area of a *facility* shall not impose a requirement for greater accessibility than that which would be required for new construction. *Alterations* shall not reduce or have the effect of reducing accessibility of a *facility* or portion of a *facility*.

### **806.2 Alterations affecting an area containing a primary function.**

Where an *alteration* affects the accessibility to a, or contains an area of, *primary function*, the route to the primary function area shall be accessible. The accessible route to the *primary function* area shall include toilet facilities and drinking fountains serving the area of *primary function*.

**Exceptions:**

- ~~1. The costs of providing the accessible route are not required to exceed 20 percent of the costs of the alterations affecting the area of *primary function*.~~
- ~~2. This provision does not apply to *alterations* limited solely to windows, hardware, operating controls, electrical outlets and signs.~~
- ~~3. This provision does not apply to *alterations* limited solely to mechanical systems, electrical systems, installation or *alteration* of fire protection systems and abatement of hazardous materials.~~
- ~~4. This provision does not apply to *alterations* undertaken for the primary purpose of increasing the accessibility of a *facility*.~~
- ~~5. This provision does not apply to altered areas limited to Type B dwelling and sleeping units.~~

**~~806.23 Stairways and escalators in existing buildings.~~**

~~In *alterations* where an escalator or stairway is added where none existed previously, an accessible route shall be provided in accordance with Sections 1104.4 and 1104.5 of the *International Building Code*.~~

**SECTION 807 805  
STRUCTURAL**

**[BS] 807.1 805.1 General.**

Structural elements and systems within buildings undergoing Level 2 *alterations* shall comply with this section.

**[BS] 807.2 New structural elements.**

~~New structural elements in *alterations*, including connections and anchorage, shall comply with the *International Building Code*.~~

**[BS] 807.3 Minimum design loads.**

~~The minimum design loads on existing elements of a structure that do not support additional loads as a result of an *alteration* shall be the loads applicable at the time the building was constructed.~~

**[BS] 807.4 805.2 Existing structural elements carrying gravity loads.**

~~*Alterations* shall not reduce the capacity of existing gravity load-carrying structural elements unless it is demonstrated that the elements have the capacity to carry the applicable design gravity loads required by the *International Building Code*. Existing structural elements supporting any additional gravity loads as a result of the *alterations*, including the effects of snow drift, shall comply with the *International Building Code*.~~

Any existing gravity load-carrying structural element for which an *alteration* causes an increase in design dead, live or snow load, including snow drift effects, of more than 5 10 percent shall be replaced or altered as needed to carry the gravity loads required by the *International Building Code* for new structures. Any existing gravity load-carrying structural element whose gravity load-carrying capacity is decreased as part of the *alteration* shall be shown to have the capacity to resist the

applicable design dead, live and snow loads, including snow drift effects, required by the *International Building Code* for new structures.

**Exceptions:**

- ~~1. Structural elements whose stress is not increased by more than 10 percent.~~
1. Buildings of Group R occupancy with not more than five dwelling or sleeping units used solely for residential purposes where the altered building complies with the conventional light-frame construction methods of the *International Building Code* or the provisions of the *International Residential Code*.
- ~~2. Buildings of Group R occupancy used solely for residential purposes where the existing building and its alteration comply with the conventional light frame construction methods of the *International Building Code* or the provisions of the *International Residential Code*.~~
2. Buildings in which the increased dead load is attributable to the addition of a second layer of roof covering weighing 3 pounds per square foot (0.1437 kN/m<sup>2</sup>) or less over an existing single layer of roof covering.

**[BS] 807.5 805.3 Existing structural elements resisting lateral loads.**

Except as permitted by Section ~~807.6~~ 805.4, where the alteration increases design lateral loads, or where the alteration results in prohibited structural irregularity as defined in ASCE 7, or where the alteration decreases the capacity of any existing lateral load-carrying structural element, the structure of the altered building or structure shall ~~forces be shown to meet the wind and seismic provisions of the *International Building Code*. Reduced *International Building Code*-level seismic forces in accordance with Section 301.1.4.2~~ meet the requirements of Sections 1609 and 1613 of the *International Building Code*. Reduced seismic shall be permitted.

**~~Exception:~~ Exceptions:**

1. Any existing lateral load-carrying structural element whose demand-capacity ratio with the alteration considered is not more than 10 percent greater than its demand-capacity ratio with the alteration ignored shall be permitted to remain unaltered. For purposes of calculating demand-capacity ratios, the demand shall consider applicable load combinations with design lateral loads or forces in accordance with Sections 1609 and 1613 of *International Building Code* Sections 1609 and 1613. Reduced ~~*International Building Code*~~ level seismic forces ~~in accordance with Section 301.1.4.2~~ shall be permitted. For purposes of this exception, comparisons of demand-capacity ratios and calculation of design lateral loads, forces and capacities shall account for the cumulative effects of additions and alterations since original construction.
2. Buildings in which the increase in the demand-capacity ratio is due entirely to the addition of rooftop-supported mechanical equipment individually having an operating weight less than 400 pounds (181.4 kg) and where the total additional weight of all rooftop equipment placed after initial construction of the building is less than 10 percent of the roof dead load. For purposes of this exception, "roof" shall mean the roof level above a particular story.

**[BS] 807.6 805.4 Voluntary lateral force-resisting system alterations.**

~~Alterations of existing structural elements and additions of new structural elements that are initiated for the purpose of increasing the lateral force-resisting strength or stiffness of an existing structure and that are not required by other sections of this code shall not be required to be designed for forces conforming to the *International Building Code*, provided that an engineering analysis is submitted to show that:~~

Structural alterations that are intended exclusively to improve the lateral force-resisting system and are not required by other sections of this code shall not be required to meet the requirements of Section 1609 or Section 1613 of the *International Building Code*, provided that the following conditions are met:

1. The capacity of existing structural elements required to resist forces is not reduced;
2. ~~The lateral loading to existing structural elements is not increased either beyond its capacity or more than 10 percent;~~
- 3-2. ~~New structural elements are detailed and connected to the existing~~ or new structural elements as required by the *International Building Code* for new construction;
- 4-3. ~~New or relocated nonstructural elements are detailed and connected to existing or new structural elements as required by the *International Building Code V*~~ for new construction; and
- 5-4. ~~A dangerous condition as defined in this code is not created. Voluntary alterations to lateral force-resisting systems conducted in accordance with Appendix A and the referenced standards of this code shall be permitted.~~  
The alterations do not create a structural irregularity as defined in ASCE 7 or make an existing structural irregularity more severe.

**SECTION 808 806  
ELECTRICAL**

**808.1 806.1 New installations.**

~~All newly~~ Newly installed electrical equipment and wiring relating to work done in any work area shall comply with all applicable requirements of NFPA 70 except as provided for in Section 808.3-806.4.

**808.2 806.2 Existing installations.**

Existing wiring in all work areas in Group A-1, A-2, A-5, H and I occupancies shall be upgraded to meet the materials and methods requirements of Chapter 7.

**806.3 Health care facilities.** In Group I-2 facilities, ambulatory care facilities and outpatient clinics, any added portion of an existing electrical system shall be required to meet installation and equipment requirements in NFPA 99.

**808.3 806.4 Residential occupancies.**

In Group R-2, R-3 and R-4 occupancies and buildings regulated by the *International Residential Code*, the

requirements of Sections ~~808.3.4~~ 806.4.1 through ~~808.3.7~~ 806.4.7 shall be applicable only to work areas located within a dwelling unit.

**~~808.3.1~~ Enclosed areas.**

All ~~enclosed~~ Enclosed areas, other than closets, kitchens, basements, garages, hallways, laundry areas, utility areas, storage areas and bathrooms shall have ~~a minimum of~~ not fewer than two duplex receptacle outlets or one duplex receptacle outlet and one ceiling or wall-type lighting outlet.

**~~808.3.2~~ Kitchens.**

Kitchen areas shall have ~~a minimum of~~ not fewer than two duplex receptacle outlets.

**~~808.3.3~~ Laundry areas.**

Laundry areas shall have ~~a minimum~~ not fewer than of one duplex receptacle outlet located near the laundry equipment and installed on an independent circuit.

**~~808.3.4~~ Ground fault circuit interruption.**

Newly installed receptacle outlets shall be provided with ground fault circuit interruption as required by NFPA 70.

**~~808.3.5~~ Minimum lighting outlets.**

At least Not fewer than one lighting outlet shall be provided in every bathroom, hallway, stairway, attached garage, and detached garage with electric power, and to illuminate outdoor entrances and exits.

**~~808.3.6~~ Utility rooms and basements.**

At least Not fewer than one lighting outlet shall be provided in utility rooms and basements where such spaces are used for storage or contain equipment requiring service.

**~~808.3.7~~ Clearance for equipment.**

Clearance for electrical service equipment shall be provided in accordance with the NFPA 70.

## **SECTION 809 MECHANICAL**

**~~809.1~~ 807.1 Reconfigured or converted spaces.**

All ~~reconfigured~~ Reconfigured spaces intended for occupancy and all spaces converted to habitable or occupiable space in any *work area* shall be provided with natural or mechanical ventilation in accordance with the *International Mechanical Code*.

**Exception:** Existing mechanical ventilation systems shall comply with the requirements of Section ~~809.2~~ 807.2.

**~~809.2~~ 807.2 Altered existing systems.**

In mechanically ventilated spaces, existing mechanical ventilation systems that are altered, reconfigured, or extended shall provide not less than 5 cubic feet per minute (cfm) ( $0.0024 \text{ m}^3/\text{s}$ ) per person of outdoor air and

not less than 15 cfm (0.0071 m<sup>3</sup>/s) of ventilation air per person; or not less than the amount of ventilation air determined by the Indoor Air Quality Procedure of ASHRAE 62.62.1

**~~809.3~~ 807.3 Local exhaust.**

All ~~newly~~ Newly introduced devices, equipment, or operations that produce airborne particulate matter, odors, fumes, vapor, combustion products, gaseous contaminants, pathogenic and allergenic organisms, and microbial contaminants in such quantities as to affect adversely or impair health or cause discomfort to occupants shall be provided with local exhaust.

**SECTION ~~810~~ 808  
PLUMBING**

**~~810.1~~ 808.1 Minimum fixtures.**

~~Where the occupant load of the story is increased by more than 20 percent, plumbing fixtures for the story shall be provided in quantities specified in the *International Plumbing Code* based on the increased occupant load.~~

**808.1 Health care facilities.** In Group I-2 *facilities*, ambulatory care *facilities* and outpatient clinics, any added portion of an existing medical gas system shall be required to meet installation and equipment requirements in NFPA 99.

**SECTION ~~814~~ 809  
ENERGY CONSERVATION**

**~~814.4~~ 809.1 Minimum requirements.**

Level 2 *alterations* to *existing buildings* or structures are permitted without requiring the entire building or structure to comply with the energy requirements of the *International Energy Conservation Code* or *International Residential Code*. The *alterations* shall conform to the energy requirements of the *International Energy Conservation Code* or *International Residential Code* as they relate to new construction only.

**~~811.1.1~~ 809.1.1 Building envelope.**

~~New building envelope assemblies that are part of the *alteration* shall comply with Section R402 of the *North Carolina Energy Conservation Code* for Group R occupancies and Section C402 of the *North Carolina Energy Conservation Code* for other occupancies.~~

**~~811.1.2~~ 809.1.2 Heating and cooling systems.**

~~New heating, cooling and duct systems that are part of the *alteration* shall comply with Sections R403.1, R403.2, R403.3, R403.4, R403.6, and R403.7 of the *North Carolina Energy Conservation Code* for Group R occupancies and Section C403 of the *North Carolina Energy Conservation Code* for other occupancies.~~

**Exceptions:**



- ~~1. In Group R occupancies, an *alteration* involving a partial system replacement to an existing duct system shall not require a duct leakage test.~~
- ~~2. Compliance with Section C403.2.12 of the *North Carolina Energy Conservation Code* is not required.~~
- ~~3. Compliance with Section C403.3 of the *North Carolina Energy Conservation Code* is not required where compliance with the section would require *alterations* to existing floor, wall or roof assemblies.~~

#### **~~811.1.3 Service hot water systems.~~**

~~New service hot water systems that are part of the *alteration* shall comply with Section R403.5 of the *North Carolina Energy Conservation Code* for Group R occupancies and Section C404 of the *North Carolina Energy Conservation Code* for other occupancies.~~

#### **~~811.1.4 Lighting.~~**

~~New lighting systems that are part of the *alteration* shall comply with Section R404.1 of the *North Carolina Energy Conservation Code* for Group R occupancies and Section C405 of the *North Carolina Energy Conservation Code* for other occupancies.~~

**Exception:** *Alterations* that replace less than 50 percent of the luminaires in a space, provided that such *alterations* do not increase the installed interior lighting power.

#### **~~811.1.5 Change in space conditioning.~~**

~~In addition to the requirement of Section 811.1, projects changing unconditioned space to conditioned space and costing more than \$10,000 shall require 10 percent of the project cost to be used toward meeting the requirements of Chapter 11 of the *North Carolina Residential Code* for one- and two-family dwellings and townhouses or the *North Carolina Energy Conservation Code*. Project costs for the purpose of this section is the total project cost listed on all permits related to the work required to convert the unconditioned space to conditioned space and excludes the 10 percent added from this section. Under this section, existing building envelope elements that become a part of the building thermal envelope and are not changed are not required to be upgraded. The additional 10 percent of the project cost shall be appropriated for additional energy conservation features of choice that are addressed in Chapter 11 of the *North Carolina Residential Code* for one- and two-family dwellings and townhouses or the *North Carolina Energy Conservation Code*. In addition to the 10 percent project cost, any existing wall, ceiling, or floor cavities that are exposed during construction shall at a minimum be insulated to comply with Chapter 11 of the *North Carolina Residential Code* for one- and two-family dwellings and townhouses or the *North Carolina Energy Conservation Code* or be insulated to fill the cavity, whichever is less. Roof systems requiring air space for ventilation shall retain the ventilation space required. Projects costing less than \$10,000 are not subject to the 10 percent project cost addition provision.~~

## **CHAPTER 9 ALTERATIONS—LEVEL 3**

## SECTION 901 GENERAL

### 901.1 Scope.

Level 3 *alterations* as described in Section 505 shall comply with the requirements of this chapter.

### 901.2 Compliance.

In addition to the provisions of this chapter, work shall comply with all of the requirements of Chapters 7 and 8. The requirements of Sections 803, 804 and 805 shall apply within all *work areas* whether or not they include exits and corridors shared by more than one tenant and regardless of the occupant load.

**Exception:** Buildings in which the reconfiguration of space affecting exits or shared egress access is exclusively the result of compliance with the accessibility requirements of Section 705.2 shall not be required to comply with this chapter.

## SECTION 902 SPECIAL USE AND OCCUPANCY

### 902.1 High-rise buildings.

Any building having occupied floors more than 75 feet (22 860 mm) above the lowest level of fire department vehicle access shall comply with the requirements of Sections 902.1.1 through 902.1.3.

#### 902.1.1 Recirculating air or exhaust systems.

When a floor is served by a recirculating air or exhaust system with a capacity greater than 15,000 cubic feet per minute ( $701 \text{ m}^3/\text{s}$ ), that system shall be equipped with approved smoke and heat detection devices installed in accordance with the *International Mechanical Code*.

#### 902.1.2 Elevators.

Where there is an elevator or elevators for public use, at least one elevator serving the *work area* shall comply with this section. Existing elevators with a travel distance of 25 feet (7620 mm) or more above or below the main floor or other level of a building and intended to serve the needs of emergency personnel for fire-fighting or rescue purposes shall be provided with emergency operation in accordance with ASME A17.3. New elevators shall be provided with Phase I emergency recall operation and Phase II emergency in-car operation in accordance with ASME A17.1.

#### 902.1.3 Luminous egress path markings.

Luminous egress markings shall be installed as required by Section 1025 of the *North Carolina Building Code*.

### 902.2 Boiler and furnace equipment rooms.

Boiler and furnace equipment rooms adjacent to or within Groups I-1, I-2, I-4, R-1, R-2 and R-4 occupancies shall be enclosed by 1-hour fire resistance-rated construction.

**Exceptions:**

1. Steam boiler equipment operating at pressures of 15 pounds per square inch gauge (psig) (103.4 KPa) or less is not required to be enclosed.
2. Hot water boilers operating at pressures of 170 psig (1171 KPa) or less are not required to be enclosed.
3. Furnace and boiler equipment with 400,000 British thermal units (Btu) ( $4.22 \times 10^8$  J) per hour input rating or less is not required to be enclosed.
4. Furnace rooms protected with an automatic sprinkler system are not required to be enclosed.

**902.3 Group H.**

Where the work area includes a Group H occupancy, the building shall comply with all the requirements of the *North Carolina Building Code* for the Group H occupancy.

## **SECTION 903 BUILDING ELEMENTS AND MATERIALS**

**903.1 Existing shafts and vertical openings.**

Existing stairways that are part of the means of egress shall be enclosed in accordance with Section 803.2.1 from the highest *work area* floor to, and including, the level of exit discharge and all floors below.

**903.2 Fire separation in Group R-3.**

Fire separation in Group R-3 occupancies shall be in accordance with Section 903.2.1.

**903.2.1 Separation required.**

Where the *work area* is in any attached dwelling unit in Group R-3, any multiple single-family dwelling (townhouse) or any two-family dwellings, walls separating the dwelling units that are not continuous from the foundation to the underside of the roof sheathing shall be constructed to provide a continuous fire separation using construction materials consistent with the existing wall or complying with the requirements for new structures. All work shall be performed on the side of the dwelling unit wall that is part of the *work area*.

**Exceptions:**

1. Where *alterations* or *repairs* do not result in the removal of wall or ceiling finishes exposing the structure, walls are not required to be continuous through concealed floor spaces.
2. If not currently existing, separation is not required in the crawl space of two-family dwellings.

### **903.3 Interior finish.**

Interior finish in exits serving the *work area* shall comply with Section 803.4 between the highest floor on which there is a *work area* to the floor of exit discharge.

**903.4 Enhanced classroom acoustics.** In Group E occupancies, where the *work area* is a Level 3 alteration, enhanced classroom acoustics shall comply with Section 1207.5 of the *International Building Code* as required for new construction.

## **SECTION 904 FIRE PROTECTION**

### **904.1 Automatic sprinkler systems.**

An automatic sprinkler system shall be provided in a work area where required by Section 804.2 or this section.

**904.1.1 High-rise buildings.** High-rise buildings constructed prior to 1978 shall at a minimum comply with North Carolina General Statute 143-138, Section (i). The statute may be viewed at the following web address:  
[http://www.ncga.state.nc.us/EnactedLegislation/Statutes/HTML/BySection/Chapter\\_143/GS\\_143-138.html](http://www.ncga.state.nc.us/EnactedLegislation/Statutes/HTML/BySection/Chapter_143/GS_143-138.html).

**904.1.2 Rubbish and linen chutes.** Deleted.

**904.1.3 Upholstered furniture or mattresses.** Deleted.

**904.1.4 Groups A, B, E, F-1, H, I-1, I-3, I-4, M, R-1, R-2, R-4, S-1 and S-2.** In buildings with occupancies in Groups A, B, E, F-1, H, I-1, I-3, I-4, M, R-1, R-2, R-4, S-1 and S-2 work areas shall be provided with automatic sprinkler protection where all of the following conditions occur:

1. The *work area* is required to be provided with automatic sprinkler protection in accordance with the *International Building Code* as applicable to new construction.
2. The building site has sufficient municipal water supply for design and installation of an automatic sprinkler system.

**Exception:** If the building site does not have sufficient municipal water supply for design of an automatic sprinkler system, work areas shall be protected by an automatic smoke detection system throughout all occupiable spaces other than sleeping units or individual dwelling units that activates the occupant notification system in accordance with Sections 907.4 , 907.5 and 907.6 of the *International Building Code*.

**904.1.5 Group I-2.** In Group I-2 occupancies, an automatic sprinkler system installed in accordance with Section 903.3.1.1 of the *International Fire Building Code* shall be provided in the following:

1. In Group I-2, Condition 1, throughout the *work area*.
2. In Group I-2, Condition 2, throughout the *work area* where the *work area* is 50 percent or less of the smoke compartment.
3. In Group I-2, Condition 2, throughout the smoke compartment in which the work occurs where the *work area* exceeds 50 percent of the smoke compartment.

**904.1.6 Windowless stories.** Work located in a windowless story, as determined in accordance with the *International Building Code*, shall be sprinklered where the *work area* is required to be sprinklered under the provisions of the *International Building Code* for newly constructed buildings and the building site has a sufficient municipal water supply for the design and installation of an automatic sprinkler system.

#### **904.1.4 904.1.7 Other required automatic sprinkler systems.**

In buildings and areas listed in Table 903.2.11.6 of the *North Carolina Building Code*, *work areas* that have exits or corridors shared by more than one tenant or that have exits or corridors serving an occupant load greater than 30 shall be provided with an automatic sprinkler system under the following conditions:

1. The *work area* is required to be provided with an automatic sprinkler system in accordance with the *North Carolina Building Code* applicable to new construction;
2. The building has sufficient municipal water supply for design of an automatic sprinkler system available to the floor without installation of a new water storage tank; and
3. The work area is separated from the remainder of the building with fire barriers complying with the *North Carolina Building Code*.

#### **904.2 Fire alarm and detection systems.**

Fire alarm and detection shall be provided in accordance with 804.4.

##### **904.2.1 Manual fire alarm systems.**

Where required by the *International Building Code*, a manual fire alarm system shall be provided throughout the *work area*. Alarm notification appliances shall be provided on such floors and shall be automatically activated as required by the *International Building Code*.

##### **Exceptions:**

1. Alarm-initiating and notification appliances shall not be required to be installed in tenant spaces outside of the *work area*.
2. Visual alarm notification appliances are not required, except where an existing alarm system is upgraded or replaced or where a new fire alarm system is installed.

##### **904.2.2 Automatic fire detection.**

Where required by the *International Building Code* for new buildings, automatic fire detection systems shall be provided throughout the *work area*.

#### **904.3 Standpipes.**

Where the *work area* includes exits or corridors shared by more than one tenant and is located more than 30 feet (15 240 mm) above or below the lowest level of fire department access, a standpipe system shall be provided. Standpipes shall have an approved fire department connection with hose connections at each floor level above or below the lowest level of fire department access. Standpipe systems shall be installed in accordance with the *North Carolina Building Code*.

Standpipes systems shall be provided for high-rise buildings as required by North Carolina General Statute 143-138, Section (i).

**Exception:** The interconnection of multiple standpipe risers shall not be required.

## SECTION 905 MEANS OF EGRESS

### 905.1 General.

The means of egress shall comply with the requirements of Section 805 except as specifically required in Sections 905.2 and 905.3.

### 905.2 Means-of-egress lighting.

Means of egress from the highest *work area* floor to the floor of exit discharge shall be provided with artificial lighting within the exit enclosure in accordance with the requirements of the *International Building Code*.

### 905.3 Exit signs.

Means of egress from the highest *work area* floor to the floor of exit discharge shall be provided with exit signs in accordance with the requirements of the *International Building Code*.

905.4 Two-way communications systems. In buildings with elevator service, a two-way communication system shall be provided where required by Section 1009.8 of the *International Building Code*.

## SECTION 906 ACCESSIBILITY

### 906.1 General.

A building, ~~facility~~ or element that is altered shall comply with this section and Section 806.

### 906.2 Type B dwelling or sleeping units.

~~Where four or more Group I-1, I-2, R-1, R-2, R-3 or R-4 dwelling or sleeping units are being altered, the requirements of Section 1107 of the *International Building Code* for Type B units and Chapter 9 of the *International Building Code* for visible alarms apply only to the quantity of the spaces being altered.~~

**Exception:** ~~Group I-1, I-2, R-2, R-3 and R-4 dwelling or sleeping units where the first certificate of occupancy was issued before March 15, 1991 are not required to provide Type B dwelling or sleeping units.~~

## SECTION 907 STRUCTURAL

**[BS] 907.4 906.1 General.**

Where buildings are undergoing Level 3 *alterations* including structural *alterations*, the provisions of this section shall apply.

**[BS] 907.2 New structural elements.**

~~New structural elements shall comply with Section 807.2.~~

**[BS] 907.3 Existing structural elements carrying gravity loads.**

~~Existing structural elements carrying gravity loads shall comply with Section 807.4~~

**[BS] 907.4 906.2 Existing structural elements resisting lateral loads.**

Existing structural elements resisting lateral loads shall comply with Section 807.5. ~~Sections 907.4.1 through 907.4.6~~ 805.3. Sections 503.4 through 503.11 shall apply when existing elements of the lateral force-resisting system have been damaged due to a wind or seismic event. Repair work such as termite or rot damage shall comply with Section 606.1.

**Exceptions:**

1. Buildings of Group R occupancy with not more than five dwelling or sleeping units used solely for residential purposes that are altered based on the conventional light-frame construction methods of the *International Building Code* or in compliance with the provisions of the *International Residential Code*.
2. Deleted.

**[BS] 906.3 Seismic evaluation and design procedures.** Where required, seismic evaluation or design shall be based on the procedures and criteria in this section.

**Exception:** Seismic requirements shall not apply to detached one- and two-family dwellings.

**[BS] 906.3.1 Compliance with full seismic forces.** Where compliance requires the use of full seismic forces, the criteria shall be in accordance with one of the following:

1. One-hundred percent of the values in the *International Building Code*. Where the existing seismic force-resisting system is a type that can be designated as “Ordinary,” values of  $R$ ,  $\Omega_0$  and  $C_d$  used for analysis in accordance with Chapter 16 of the *International Building Code* shall be those specified for structural systems classified as “Ordinary” in accordance with Table 12.2-1 of ASCE 7, unless it can be demonstrated that the structural system will provide performance equivalent to that of a “Detailed,” “Intermediate” or “Special” system.
2. ASCE 41, using a Tier 3 procedure and the two-level performance objective in Table 906.3.1 for the applicable *risk category*.

**[BS] TABLE 906.3.1**

**PERFORMANCE OBJECTIVES FOR USE IN ASCE 41 FOR COMPLIANCE WITH FULL SEISMIC FORCES**

| <u>RISK CATEGORY (Based on IBC Table 1604.5)</u> | <u>STRUCTURAL PERFORMANCE LEVEL FOR USE WITH BSE-1N EARTHQUAKE HAZARD LEVEL</u> | <u>STRUCTURAL PERFORMANCE LEVEL FOR USE WITH BSE-2N EARTHQUAKE HAZARD LEVEL</u> |
|--|---|---|
| <u>I</u>   | <u>Life Safety (S-3)</u>  | <u>Collapse Prevention (S-5)</u>  |
| <u>II</u>  | <u>Life Safety (S-3)</u>  | <u>Collapse Prevention (S-5)</u>  |
| <u>III</u>                                       | <u>Damage Control (S-2)</u>   | <u>Limited Safety (S-4)</u>   |
| <u>IV</u>  | <u>Immediate Occupancy (S-1)</u>  | <u>Life Safety (S-3)</u>  |

**[BS] 906.3.2 Compliance with reduced seismic forces.** Where seismic evaluation and design is permitted to use reduced seismic forces, the criteria used shall be in accordance with one of the following:

1. The *International Building Code* using 75 percent of the prescribed forces. Values of  $R$ ,  $\Omega_0$  and  $C_d$  used for analysis shall be as specified in Section 906.3.1 of this code.
2. Structures or portions of structures that comply with the requirements of the applicable chapter in Appendix A as specified in Items 2.1 through 2.4 and subject to the limitations of the respective Appendix A chapters shall be deemed to comply with this section.
  - 2.1. The seismic evaluation and design of unreinforced masonry bearing wall buildings in *Risk Category* I or II are permitted to be based on the procedures specified in Appendix Chapter A1.
  - 2.2. Seismic evaluation and design of the wall anchorage system in reinforced concrete and reinforced masonry wall buildings with flexible diaphragms in *Risk Category* I or II are permitted to be based on the procedures specified in Chapter A2.
  - 2.3. Seismic evaluation and design of cripple walls and sill plate anchorage in residential buildings of light-frame wood construction in *Risk Category* I or II are permitted to be based on the procedures specified in Chapter A3.
  - 2.4. Seismic evaluation and design of soft, weak or open-front wall conditions in multiple-unit residential buildings of wood construction in *Risk Category* I or II are permitted to be based on the procedures specified in Chapter A4.
3. ASCE 41, using the performance objective in Table 906.3.2 for the applicable *risk category*.

**[BS] TABLE 906.3.2**

**PERFORMANCE OBJECTIVES FOR USE IN ASCE 41 FOR COMPLIANCE WITH REDUCED SEISMIC FORCES**

| <u>RISK CATEGORY (Based on IBC Table 1604.5)</u> | <u>STRUCTURAL PERFORMANCE LEVEL FOR USE WITH BSE-1E EARTHQUAKE HAZARD LEVEL</u> | <u>STRUCTURAL PERFORMANCE LEVEL FOR USE WITH BSE-2E EARTHQUAKE HAZARD LEVEL</u> |
|--|---|---|
| <u>I</u>   | <u>Life Safety (S-3).<br/>See Note a</u>  | <u>Collapse Prevention (S-5)</u>  |
| <u>II</u>  | <u>Life Safety (S-3).<br/>See Note a</u>  | <u>Collapse Prevention (S-5)</u>  |
| <u>III</u>                                       | <u>Damage Control (S-2).<br/>See Note a</u>                                     | <u>Limited Safety (S-4).<br/>See Note b</u>                                     |



|           |                                      |  |
|-----------|--------------------------------------|--|
| <u>IV</u> | <u>Immediate Occupancy<br/>(S-1)</u> | <u>Life Safety (S-3).<br/>See Note c</u> |
|-----------|--------------------------------------|--|

- a. For Risk Categories I, II and III, the Tier 1 and Tier 2 procedures need not be considered for the BSE-1E earthquake hazard level.
- b. For Risk Category III, the Tier 1 screening checklists shall be based on the Collapse Prevention, except that checklist statements using the Quick Check provisions shall be based on *MS*-factors that are the average of the values for Collapse Prevention and Life Safety.
- c. For Risk Category IV, the Tier 1 screening checklists shall be based on Collapse Prevention, except that checklist statements using the Quick Check provisions shall be based on *MS*-factors for Life Safety.

**~~[BS] 907.4.1 Evaluation and analysis.~~**

~~An engineering evaluation and analysis that establishes the structural adequacy of the altered structure shall be prepared by a registered design professional and submitted to the code official.~~

**~~[BS] 907.4.2 Substantial structural alteration.~~**

~~Where more than 30 percent of the total floor and roof areas of the building or structure have been or are proposed to be involved in structural *alteration* within a 5-year period, the evaluation and analysis shall demonstrate that the lateral load-resisting system of the altered building or structure complies with the *International Building Code* for wind loading and with reduced *International Building Code* level seismic forces in accordance with Section 301.1.4.2. The areas to be counted toward the 30 percent shall be those areas tributary to the vertical load-carrying components, such as joists, beams, columns, walls and other structural components that have been or will be removed, added or altered, as well as areas such as mezzanines, penthouses, roof structures and in-filled courts and shafts.~~

**~~[BS] 907.4.3 Seismic Design Category F. Deleted.~~**

**~~[BS] 907.4.4 Limited structural alteration.~~**

~~Where the work does not involve a substantial structural *alteration*, the existing elements of the lateral load-resisting system shall comply with Section 807.5.~~

**~~[BS] 907.4.5 Wall anchors for concrete and masonry buildings.~~**

~~For any building assigned to Seismic Design Category D, E or F with a structural system consisting of concrete or reinforced masonry walls with a flexible roof diaphragm and any building assigned to Seismic Design Category C, D, E or F with a structural system consisting of unreinforced masonry walls with any type of roof diaphragm, the alteration work shall include installation of wall anchors at the roof line to resist the reduced *International Building Code* level seismic forces in accordance with Section 301.1.4.2, unless an evaluation demonstrates compliance of existing wall anchorage.~~

**~~[BS] 907.4.6 Bracing for unreinforced masonry parapets.~~**

~~Parapets constructed of unreinforced masonry in buildings assigned to Seismic Design Category C, D, E or F shall have bracing installed as needed to resist the reduced *International Building Code* level seismic forces in accordance with Section 301.1.4.2, unless an evaluation demonstrates compliance of such items.~~

**~~[BS] 906.4 Anchorage for concrete and masonry buildings. Deleted~~**

**~~[BS] 906.5 Anchorage for unreinforced masonry walls. Deleted.~~**

[BS] 906.6 Bracing for unreinforced masonry parapets. Deleted

[BS] 906.7 Anchorage of unreinforced masonry partitions. Deleted.

## SECTION 908 ENERGY CONSERVATION

### 908.1 Minimum requirements.

Level 3 *alterations* to *existing buildings* or structures are permitted without requiring the entire building or structure to comply with the energy requirements of the *International Energy Conservation Code* or *International Residential Code*. The *alterations* shall conform to this section and Sections 708 and 811, the energy requirements of the *International Energy Conservation Code* or *International Residential Code* as they relate to new construction only.

#### ~~908.1.1 Building envelope.~~

~~New building envelope assemblies that are part of the *alteration* shall comply with Section R402 of the *North Carolina Energy Conservation Code* for Group R occupancies and Section C402 of the *North Carolina Energy Conservation Code* for other occupancies.~~

#### ~~908.1.1.1 Vertical fenestration.~~

~~The addition of *vertical fenestration* that results in a total building *fenestration* area less than or equal to that specified in Section C402.4.1 of the *North Carolina Energy Conservation Code* shall comply with Section C402.4 of the *North Carolina Energy Conservation Code*. The addition of *vertical fenestration* that results in a total building *fenestration* area greater than Section C402.4.1 of the *North Carolina Energy Conservation Code* shall comply with Section C407 of the *North Carolina Energy Conservation Code*.~~

#### ~~908.1.1.2 Skylight area.~~

~~The addition of *skylight* area that results in a total building *skylight* area less than or equal to that specified in Section C402.4.1 of the *North Carolina Energy Conservation Code* shall comply with Section C402.4 of the *North Carolina Energy Conservation Code*. The addition of *skylight* area that results in a total building *skylight* area greater than Section C402.4.1 of the *North Carolina Energy Conservation Code* shall comply with Section C407 of the *North Carolina Energy Conservation Code*. *Alterations* that result in a total building *skylight* area exceeding that specified in Section C402.4.1 of the *North Carolina Energy Conservation Code* shall comply with Section C407 of the *North Carolina Energy Conservation Code*.~~

## CHAPTER 10 CHANGE OF OCCUPANCY

## SECTION 1001 GENERAL

### 1001.1 Scope.

The provisions of this chapter shall apply where a *change of occupancy* occurs, as defined in Section 202, including:

1. Where the occupancy use is changed; or
2. Where there is a change in occupancy classification or the occupancy group designation changes.

Any *repair or alteration* work undertaken in connection with a *change of occupancy* shall conform to the other applicable chapters of this code.

### 1001.2 Change in occupancy with no change of occupancy classification.

A change in occupancy, as defined in Section 202, with no *change of occupancy* classification shall not be made to any structure that will subject the structure to any special provisions of the applicable *International Codes*, including the provisions of Sections 1002 through 1011, without the approval of the *code official*. A certificate of occupancy shall be issued where it has been determined that the requirements for the change in occupancy have been met.

#### 1001.2.1 Additional requirements for Group A-2 nightclubs.

When a Group A-2 occupancy changes the use to a nightclub, fire protection shall be provided in accordance with Section ~~1012.2~~ in addition to the requirements of Section 1001.2.

#### 1001.2.2 Repair and alteration with no change of occupancy classification.

Any *repair or alteration* work undertaken in connection with a *change of occupancy* that does not involve a *change of occupancy* classification shall conform to the applicable requirements for the work as classified in Chapter 5 and to the requirements of Sections 1002 through 1011.

**Exception:** As modified in Section 1205 for *historic buildings*.

#### 1001.2.3 Change or partial change of occupancy classification or group.

Where the occupancy classification changes, the provisions of Sections 1002 through ~~4042~~ shall apply. This includes a *change of occupancy* classification within a group as well as a *change of occupancy* classification from one group to a different group

~~1001.2.3.1 Partial change of occupancy. Deleted.~~

**1001.3 Certificate of occupancy required.**

A new certificate of occupancy shall be required where a *change of occupancy* occurs that results in a different occupancy classification as determined by Chapter 3 of the *International Building Code*.

**SECTION 1002  
SPECIAL USE AND OCCUPANCY**

**1002.1 Compliance with the building code.**

Where ~~the character or use of an existing building or part of an existing building is changed~~ undergoes a change of occupancy to one of the following special use or occupancy categories as ~~defined~~ described in Chapter 4 in the *International Building Code*, the building shall comply with all of the ~~applicable~~ requirements of Chapter 4 of the International Building Code applicable to the special use or occupancy.

- ~~1. Covered and open mall buildings.~~
- ~~2. Atriums.~~
- ~~3. Motor vehicle-related occupancies.~~
- ~~4. Aircraft-related occupancies.~~
- ~~5. Motion picture projection rooms.~~
- ~~6. Stages and platforms.~~
- ~~7. Special amusement buildings.~~
- ~~8. Incidental use areas.~~
- ~~9. Hazardous materials.~~
- ~~10. Ambulatory care facilities.~~
- ~~11. Group I-2 occupancies.~~

#### **~~1002.2~~ Underground buildings.**

An underground building in which there is a change of use shall comply with the requirements of the *International Building Code* applicable to underground structures.

**1002.2 Incidental uses.** Where a portion of a building undergoes a *change of occupancy* to one of the incidental uses listed in Table 509.1 of the *International Building Code*, the incidental use shall comply with Section 509 of the *International Building Code* applicable to the incidental use.

**1002.3 Change of occupancy in health care.** Where a *change of occupancy* occurs to a Group I-2 or I-1 facility, the work area with the *change of occupancy* shall comply with the *International Building Code*.

**Exception:** A change in use or occupancy in the following cases shall not be required to meet the *International Building Code*:

1. Group I-2, Condition 2 to Group I-2, Condition 1.
2. Group I-2 to ambulatory health care.
3. Group I-2 to Group I-1.
4. Group I-1, Condition 2 to Group I-1, Condition 1.

**1002.4 Storage.** In Group I-2 occupancies, equipped throughout with an automatic sprinkler in accordance with Section 903.3.1.1 of the *International Building Code*, where a room 250 square feet (23.2 m<sup>2</sup>) or less undergoes a change in occupancy to a storage room, the room shall be separated from the remainder of the building by construction capable of resisting the passage of smoke in accordance with Section 509.4.2 of the *International Building Code*.

## **SECTION 1003 BUILDING ELEMENTS AND MATERIALS**

### **1003.1 General.**

Building elements and materials in portions of buildings undergoing a *change of occupancy* classification shall comply with Section ~~4042.~~ 1011.

## **SECTION 1004 FIRE PROTECTION**

### **1004.1**

### **General.**

Fire protection requirements of Section ~~4042.~~ 1011 shall apply where a building or portions thereof undergo a *change of occupancy* classification or where there is a change of occupancy within a space where there is a different fire protection system threshold requirement in Chapter 9 of the *International Building Code*.

## **SECTION 1005 MEANS OF EGRESS**

### **1005.1 General.**

Means of egress in portions of buildings undergoing a *change of occupancy* classification shall comply with Section ~~4042.~~ 1011.

## SECTION 1006 ACCESSIBILITY

### ~~1006.1 General.~~

~~Accessibility in portions of buildings undergoing a *change of occupancy* classification shall comply with Section 1012.9.~~

## SECTION 1007 STRUCTURAL

### **[BS] 1007.1 Gravity loads. 1006.1 Live Loads**

~~Buildings or portions thereof subject to a *change of occupancy* where such change in the nature of occupancy results in higher uniform or concentrated loads based on Table 1607.1 of the *International Building Code* shall comply with the gravity load provisions of the *International Building Code*.~~

Structural elements carrying tributary live loads from an area with a *change of occupancy* shall satisfy the requirements of Section 1607 of the *International Building Code*. Design live loads for areas of new occupancy shall be based on Section 1607 of the *International Building Code*. Design live loads for other areas shall be permitted to use previously *approved* design live loads.

#### **Exceptions:**

1. Structural elements whose stress is not increased by more than ~~5~~ 10 percent. demand-capacity ratio considering the *change of occupancy* is not more than 10 percent greater than the demand-capacity ratio based on previously *approved* live loads.
2. A *change of occupancy* from Group R-3 to Group B or E occupancy is permitted when the gravity live load is increased by 10 ~~psf~~ pounds per square foot (0.48 kN/m<sup>2</sup>) or less.

### **[BS] 1007.2 1006.2 Snow and wind loads.**

~~Buildings and structures subject to a *change of occupancy* where such change in the nature of occupancy results in higher wind or snow risk categories based on Table 1604.5 of the *International Building Code* shall be analyzed and shall comply with the applicable wind or snow load provisions of the *International Building Code*.~~

Where a *change of occupancy* results in a structure being assigned to a higher *risk category*, the structure shall satisfy the requirements of Sections 1608 and 1609 of the *International Building Code* for the new risk category.

~~**Exception:** Where the new occupancy with a higher risk category is less than or equal to 10 percent of the total building floor area. The cumulative effect of the area of occupancy changes shall be considered for the purposes of this exception.~~

**Exception:** Where the area of the new occupancy is less than 10 percent of the building area. The cumulative effect of occupancy changes over time shall be considered.

**[BS] 1007.3- 1006.3 -Seismic loads.**

~~Existing buildings with a change of occupancy shall comply with the seismic provisions of Sections 1007.3.1 and 1007.3.2.~~

**[BS] 1007.3.1 Compliance with International Building Code-level seismic forces.**

~~Where a building or portion thereof is subject to a change of occupancy that results in the building being assigned to a higher risk category based on Table 1604.5 of the International Building Code, the building shall comply with the requirements for International Building Code-level seismic forces as specified in Section 301.1.4.1 for the new risk category.~~

**Exceptions:**

- ~~1. Where approved by the code official, specific detailing provisions required for a new structure are not required to be met where it can be shown that an equivalent level of performance and seismic safety is obtained for the applicable risk category based on the provision for reduced International Building Code-level seismic forces as specified in Section 301.1.4.2.~~
- ~~2. Where the area of the new occupancy with a higher hazard category is less than or equal to 10 percent of the total building floor area and the new occupancy is not classified as Risk Category IV. For the purposes of this exception, buildings occupied by two or more occupancies not included in the same risk category, shall be subject to the provisions of Section 1604.5.1 of the International Building Code. The cumulative effect of the area of occupancy changes shall be considered for the purposes of this exception.~~
- ~~3. Unreinforced masonry bearing wall buildings in Risk Category III when assigned to Seismic Design Category A or B shall be allowed to be strengthened to meet the requirements of Appendix Chapter A1 of this code [Guidelines for the Seismic Retrofit of Existing Buildings (GSREB)].~~

Where a change of occupancy results in a building being assigned to a higher risk category, or where the change is from a Group S or Group U occupancy to any occupancy other than Group S or Group U, the building shall satisfy the requirements of Section 1613 of the International Building Code for the new risk category using full seismic forces.

**Exceptions:**

1. Where a change of use results in a building being reclassified from Risk Category I or II to Risk Category III and the seismic coefficient,  $S_{DS}$ , is less than 0.33, compliance with this section is not required.
2. Where the area of the new occupancy is less than 10 percent of the building area, the occupancy is not changing from a Group S or Group U occupancy, and the new occupancy is not assigned to Risk Category IV, compliance with this section is not required. The cumulative effect of occupancy changes over time shall be considered.
3. Unreinforced masonry bearing wall buildings assigned to Risk Category III and to Seismic Design Category A or B shall be permitted to use Appendix Chapter A1 of this code.
4. Where the change is from a Group S or Group U occupancy and there is no change of risk category, use of reduced seismic forces shall be permitted.

**[BS] ~~1007.3.2~~ 1006.4 Access to Risk Category IV.**

~~Where a *change of occupancy* is such that compliance with Section 1007.3.1 is required and the building is assigned to Risk Category IV, the operational access to the building shall not be through an adjacent structure, unless that structure conforms to the requirements for Risk Category IV structures. Where operational access is less than 10 feet (3048 mm) from either an interior lot line or from another structure, access protection from potential falling debris shall be provided by the owner of the Risk Category IV structure.~~

Any structure that provides operational access to an adjacent structure assigned to *Risk Category IV* as the result of a change of occupancy shall itself satisfy the requirements of Sections 1608, 1609 and 1613 of the *International Building Code*. For compliance with Section 1613 of the *International Building Code*, the full seismic forces shall be used. Where operational access to *Risk Category IV* is less than 10 feet (3048 mm) from either an interior lot line or from another structure, access protection from potential falling debris shall be provided.

**SECTION ~~1008-1007~~  
ELECTRICAL**

**~~1008.1~~ 1007.1 Special occupancies.**

Where the occupancy of an *existing building* or part of an *existing building* is changed to one of the following special occupancies as described in NFPA 70, the electrical wiring and equipment of the building or portion thereof that contains the proposed occupancy shall comply with the applicable requirements of NFPA 70 ~~whether or not a *change of occupancy* group is involved.~~ Health care *facilities*, including Group I-2, ambulatory health care *facilities* and outpatient clinics, shall also comply with the applicable requirements of NFPA 99:

1. Hazardous locations.
2. Commercial garages, *repair*, and storage.
3. Aircraft hangars.
4. Gasoline dispensing and service stations.
5. Bulk storage plants.
6. Spray application, dipping, and coating processes.
7. Health care facilities- , including Group I-2, ambulatory health care *facilities* and outpatient clinics.
8. Places of assembly.



9. Theaters, audience areas of motion picture and television studios, and similar locations.
10. Motion picture and television studios and similar locations.
11. Motion picture projectors.
12. Agricultural buildings.

**1008.2 Unsafe conditions.**

Where the occupancy of an *existing building* or part of an *existing building* is changed, all unsafe conditions shall be corrected without requiring that all parts of the electrical system comply with NFPA 70.

**1008.3 Service upgrade.**

Where the occupancy of an *existing building* or part of an *existing building* is changed such that the new load requires an increase in service, the electrical service shall be upgraded to meet the requirements of NFPA 70 for the new occupancy.

**1008.4 Number of electrical outlets.**

Where the occupancy of an *existing building* or part of an *existing building* is changed, the number of electrical outlets shall comply with NFPA 70 for the new occupancy.

**SECTION ~~4009~~ 1008  
MECHANICAL**

**~~4009.1~~ 1008.1 Mechanical requirements.**

Where the occupancy of an *existing building* or part of an *existing building* is changed such that the new occupancy is subject to different kitchen exhaust requirements or to increased mechanical ventilation requirements in accordance with the *International Mechanical Code*, the new occupancy shall comply with the respective *International Mechanical Code* provisions.

**SECTION ~~4040~~ 1009  
PLUMBING**

**~~4040.1~~ 1009.1 Increased demand.**

Where the occupancy of an *existing building* or part of an *existing building* is changed such that the new occupancy is subject to increased or different plumbing fixture requirements or to increased water supply requirements in accordance with the *International Plumbing Code*, the new occupancy shall comply with the intent of the respective *International Plumbing Code* provisions.

**\*\* Exception: Only where the occupant load of the story is increased by more than 20 percent, plumbing fixtures for the story shall be provided in quantities specified in the *International Plumbing Code* based on the increased occupant load.**

**4040.2 1009.2 Food-handling occupancies.**

If the new occupancy is a food-handling establishment, all existing sanitary waste lines above the food or drink preparation or storage areas shall be panned or otherwise protected to prevent leaking pipes or condensation on pipes from contaminating food or drink. New drainage lines shall not be installed above such areas and shall be protected in accordance with the *International Plumbing Code*.

**4040.3 1009.3 Interceptor required.**

If the new occupancy will produce grease or oil-laden wastes, interceptors shall be provided as required in the *International Plumbing Code*.

**4040.4 1009.4 Chemical wastes.**

If the new occupancy will produce chemical wastes, the following shall apply:

1. If the existing piping is not compatible with the chemical waste, the waste shall be neutralized prior to entering the drainage system, or the piping shall be changed to a compatible material.
2. ~~No chemical~~ Chemical waste shall discharge to a public sewer system without the approval of the sewage authority.

**4040.5 1009.5 Group I-2.**

If the occupancy group is changed to Group I-2, the plumbing system shall comply with the applicable requirements of the *International Plumbing Code*.

**SECTION 4044 1010  
OTHER REQUIREMENTS**

**4044.1 1010.1 Light and ventilation.**

Natural light and natural ventilation shall comply with the requirements of the *International Building Code* or *North Carolina Residential Code* for the new occupancy.

**SECTION 4012-4014  
CHANGE OF OCCUPANCY CLASSIFICATION**

**4012.1**

**1011.1**

**General.**

The provisions of this section shall apply to buildings or portions thereof undergoing a change of occupancy classification. This includes a change of occupancy classification within a group as well as a change of occupancy classification from one group to a different group or where there is a change of occupancy within a space where there is a different fire protection system threshold requirement in Chapter 9 of the *International Building Code*. Such buildings shall also comply with Sections 1002 through 4044.1010 of this code. ~~The application of requirements for the change of occupancy shall be as set forth in Sections 1012.1.1 1011.1.1 through 1012.1.4 4011.1.4. A change of occupancy, as defined in Section 202, without a corresponding change of occupancy classification shall comply with Section 1001.2.~~ For the purposes of this section, Group R-3 shall also include detached one- and two-family dwellings and townhouses.

#### **4012.1.1 Compliance with Chapter 9.**

Where alteration work is required by the change of occupancy classification the requirements of Chapter 9 shall be applicable throughout the building for the most restrictive occupancy classification.

**Exception:** Where a portion of an *existing building* that is changed to a new occupancy classification and that portion is separated from the remainder of the building with fire barriers having a fire resistance rating as required in the *International Building Code* for the separate occupancy, that portion shall comply with all of the requirements of Chapter 9 of this code for the most restrictive occupancy in the fire area and with the requirements of this chapter.

#### **~~4012.1.1.1 Change of occupancy classification without separation. Deleted.~~**

#### **~~4012.1.1.2 Change of occupancy classification with separation. Deleted.~~**

#### **4012.1.2 Fire protection and interior finish.**

The provisions of Sections 1012.2 and 1012.3 for fire protection and interior finish, respectively, shall apply to all buildings undergoing a change of occupancy classification.

#### **4012.1.3 Change of occupancy classification based on hazard category.**

The relative degree of hazard between different occupancy classifications shall be determined in accordance with the categories specified in Tables 1012.4, 1012.5 and 1012.6. Such a determination shall be the basis for the application of Sections 1012.4 through 1012.7.

#### **4012.1.4 Accessibility.**

All buildings undergoing a change of occupancy classification shall comply with Section 1012.9.

### **4012.2 Fire protection systems.**

Fire protection systems shall be provided in accordance with Sections 4012.1.2, 1011.2.1 and 4012.2.2, 1011.2.2.

#### **4012.2.1 Fire sprinkler system.**

Hazard categories in regard to fire sprinkler requirements shall be in accordance with Table 1012.2.1.

Where a change in occupancy classification occurs or where there is a *change of occupancy* within a space where there is a different fire protection system threshold requirement in Chapter 9 of the *International Building Code* that requires an automatic fire sprinkler system to be provided based on the new occupancy in accordance with Chapter 9 of the *International Building Code*. The installation of the automatic sprinkler system shall be required within the area of the *change of occupancy* and areas of the building not separated horizontally and vertically from the change of occupancy by one of the following:

1. Nonrated permanent partition and horizontal assemblies.
2. Fire partition.

3. Smoke partition.
4. Smoke barrier.
5. Fire barrier.
6. Fire wall.

**Exceptions:**

1. An automatic sprinkler system shall not be required in a one- or two-family dwelling constructed in accordance with the *International Residential Code*.
2. Automatic sprinkler system shall not be required in a townhouse constructed in accordance with the *International Residential Code*.
3. The townhouse shall be separated from adjoining units in accordance with Section R302.2 of the *International Residential Code*.

**TABLE ~~1012.2.1~~.1011.2.1**  
**SPRINKLER HAZARD CATEGORIES**

| RELATIVE HAZARD    | OCCUPANCY USE CLASSIFICATIONS |
|--------------------|-------------------------------|
| 1 (Highest Hazard) | H, I, <i>Nightclub</i>        |
| 2                  | A-2, R-1, R-2                 |
| 3                  | A-1, A-3                      |
| 4                  | F-1, M, S-1                   |
| 5                  | A-4, E                        |
| 6 (Lowest Hazard)  | B, F-2, R-3, R-4, S-2, U      |

**~~1012.2.1.1~~ 1011.2.1.1 Change to higher hazard category.**

When a change of use is made to a higher hazard category as shown in Table ~~1012.2.1~~, the building shall be provided with an automatic fire suppression system as required by Section 903 of the *North Carolina Building Code*.

**Exception:** When an area of a building is changed to a higher hazard category and the proposed use is separated from the existing use(s) by assemblies that meet the applicable fire rating in Table 508.4 of the *North Carolina Building Code*, an automatic fire suppression system as required above shall be installed only in the area changed.

**~~1012.2.1.2~~ 1011.2.1.2 Change to equal or lesser hazard category.**

When a change of use is made to an equal or lesser hazard category as shown in Table ~~1012.2.1~~, there is no requirement to install an automatic fire suppression system.

**Exceptions:**

1. In areas where work being performed in connection with the change of use triggers a requirement for suppression.
2. In windowless stories an automatic fire suppression system shall be installed as required by Section 903 of the *North Carolina Building Code*.

**~~4012.2.1.3~~ 1011.2.1.3 Change in NFPA 13 hazard level.**

Notwithstanding the relative hazard as determined by Table ~~4012.2.1~~, when a change in the character of the use is made to a higher degree of hazard as defined by NFPA 13 (Light Hazard, Ordinary Hazard Group 1, Ordinary Hazard Group 2, Extra Hazard Group 1, Extra Hazard Group 2 and Special Occupancy Hazards), the sprinkler system shall be evaluated and, where required by NFPA 13, altered to conform to the required density and maximum sprinkler protection area per head for the proposed occupancy.

**~~4042.2.2~~ 1011.2.2 Fire alarm and detection system and carbon monoxide alarm system.**

Where a change in occupancy classification occurs or where there is a change of occupancy within a space where there is a different fire protection system threshold requirement in Chapter 9 of the *International Building Code* that requires a fire alarm and detection system or carbon monoxide alarm system to be provided based on the new occupancy in accordance with Chapter 9 of the *International Building Code*, such system shall be provided throughout the area where the *change of occupancy* occurs. Existing alarm notification appliances shall be automatically activated throughout the building. Where the building is not equipped with a fire alarm system, alarm notification appliances shall be provided throughout the area where the *change of occupancy* occurs in accordance with Section 907 of the *International Building Code* as required for new construction.

**~~4042.3~~ 1011.3 Interior finish.**

In areas of the building undergoing the change of occupancy classification, the interior finish of walls and ceilings shall comply with the requirements of the *International Building Code* for the new occupancy classification.

**1011.4 Enhanced classroom acoustics. Deleted.**

**~~4042.4~~ 1011.5 Means of egress, general.**

Hazard categories in regard to life safety and means of egress shall be in accordance with Table ~~4042.4~~.1011.5

**TABLE ~~4042.4~~ 1011.5  
MEANS OF EGRESS HAZARD CATEGORIES**

| RELATIVE HAZARD    | OCCUPANCY CLASSIFICATIONS |
|--------------------|---------------------------|
| 1 (Highest Hazard) | H                         |

|                   |   |
|-------------------|---|
| 2                 | I-2, I-3, I-4   |
| 3                 | A, E, I-1, M, R-1, R-2, R-4, <u>Condition 2</u>         |
| 4                 | B, F-1, R-3 <sup>a</sup> , R-4 <u>Condition 1</u> , S-1 |
| 5 (Lowest Hazard) | F-2, S-2, U   |

a. Detached one- and two-family dwellings and townhouses are relative hazard 5.

**4012.4.4.1011.5.1 Means of egress for change to higher hazard category.**

When a change of occupancy classification is made to a higher hazard category (lower number) as shown in Table 4012.4 1011.5, the means of egress shall comply with the requirements of Chapter 10 of the *International Building Code*.

**Exceptions:**

1. Stairways shall be enclosed in compliance with the applicable provisions of Section 903.1.
2. Existing stairways including handrails and guards complying with the requirements of Chapter 9 shall be permitted for continued use subject to approval of the *code official*.
3. Any stairway replacing an existing stairway within a space where the pitch or slope cannot be reduced because of existing construction shall not be required to comply with the maximum riser height and minimum tread depth requirements.
4. Existing corridor walls constructed on both sides of wood lath and plaster in good condition or  $\frac{1}{2}$ -inch-thick (12.7 mm) gypsum wallboard shall be permitted where 1-hour rated separation is required. Such walls shall either terminate at the underside of a ceiling of equivalent construction or extend to the underside of the floor or roof next above.
5. Existing corridor doorways, transoms and other corridor openings shall comply with the requirements in Sections 805.5.1, 805.5.2 and 805.5.3. ~~804.6.1, 804.6.2 and 804.6.3.~~
6. Existing dead-end corridors shall comply with the requirements in Section ~~805.6.~~ 804.7
7. An existing operable window with clear opening area no less than 4 square feet ( $0.38\text{ m}^2$ ) and minimum opening height and width of 22 inches (559 mm) and 20 inches (508 mm), respectively, complying with Section 1011.5.6 shall be accepted as an emergency escape and rescue opening.

**4012.4.2.1011.5.2 Means of egress for change of use to equal or lower hazard category.**

When a change of occupancy classification is made to an equal or lesser hazard category (higher number) as shown in Table 4012.4 1011.5, existing elements of the means of egress shall comply with the

requirements of Section 905 for the new occupancy classification. Newly constructed or configured means of egress shall comply with the requirements of Chapter 10 of the *International Building Code*.

**Exception:** Any stairway replacing an existing stairway within a space where the pitch or slope cannot be reduced because of existing construction shall not be required to comply with the maximum riser height and minimum tread depth requirements.

**~~4012.4.3.~~ 1011.5.3 Egress capacity.**

Egress capacity shall meet or exceed the occupant load as specified in the *International Building Code* for the new occupancy.

**Exception:** The occupant load of the space may be restricted to comply with Section 1006 of the *North Carolina Building Code*. Signage indicating the allowed quantity of occupants shall be permanently mounted in the building at a location approved by the local fire marshal.

**~~4012.4.4~~ 1011.5.4 Handrails.**

Existing stairways shall comply with the handrail requirements of Section ~~805.9~~ 804.10 in the area of the change of occupancy classification.

**~~4012.4.5.~~ 1011.5.5 Guards.**

Existing guards shall comply with the requirements in Section ~~805.14~~ 804.12 in the area of the change of occupancy classification.

**1011.5.6 Existing emergency escape and rescue openings.** *Where a change of occupancy would require an emergency escape and rescue opening in accordance with Section 1031 of the International Building Code or Section R310 of the North Carolina Residential Code, operable windows serving as the emergency escape and rescue opening shall comply with the following:*

1. An existing operable window shall provide a minimum net clear opening of 4 square feet (0.38 m<sup>2</sup>) with a minimum net clear opening height of 22 inches (559 mm) and a minimum net clear opening width of 20 inches (508 mm).
2. A replacement window where such window complies with both of the following:
  - 2.1. The replacement window meets the size requirements in Item 1.
  - 2.2. The replacement window is the manufacturer's largest standard size window that will fit within the existing frame or existing rough opening. The replacement window shall be permitted to be of the same operating style as the existing window or a style that provides for an equal or greater window opening area than the existing window.

**~~4012.5~~ 1011.6 Heights and areas.**

Hazard categories in regard to height and area shall be in accordance with Table ~~4012.5.~~1011.6.

**TABLE ~~4012.5~~ 1011.6  
HEIGHTS AND AREAS HAZARD CATEGORIES**

| RELATIVE HAZARD    | OCCUPANCY CLASSIFICATIONS                          |
|--------------------|--|
| 1 (Highest Hazard) | H <sup>a</sup>                                     |
| 2                  | A-1, A-2, A-3, A-4, I <sup>a</sup>                 |
| 3                  | E, F-1, R-1, R-2, R-4 <u>Condition 2</u> , S-1, M  |
| 4 (Lowest Hazard)  | B, F-2, S-2, A-5, R-3, <u>R-4, Condition 1</u> , U |

a. H-1 and I-2 are not permitted in Type VB construction.

**4042.5.4 1011.6.1 Height and area for change to higher hazard category.**

When a change of occupancy classification is made to a higher hazard category as shown in Table 4042.5 1011.6, heights and areas of buildings and structures shall comply with the requirements of Chapter 5 of the *International Building Code* for the new occupancy classification.

**Exception:** For high-rise buildings constructed in compliance with a previously issued permit, the type of construction reduction specified in Section 403.2.1 of the *International Building Code* is permitted. This shall include the reduction for columns. The high-rise building is required to be equipped throughout with an automatic sprinkler system in accordance with Section 903.3.1.1 of the *International Building Code*.

**4042.5.4.4 1011.6.1.1 Fire wall alternative.**

In other than Groups H, F-1 and S-1, fire barriers and horizontal assemblies constructed in accordance with Sections 707 and 711, respectively, of the *International Building Code* shall be permitted to be used in lieu of fire walls to subdivide the building into separate buildings for the purpose of complying with the area limitations required for the new occupancy where all of the following conditions are met:

1. The buildings are protected throughout with an automatic sprinkler system in accordance with Section 903.3.1.1 of the *International Fire Code*.
2. The maximum allowable area between fire barriers, horizontal assemblies, or any combination thereof shall not exceed the maximum allowable area determined in accordance with Chapter 5 of the *International Building Code* without an increase allowed for an automatic sprinkler system in accordance with Section 506 of the *International Building Code*.
3. The fire-resistance rating of the fire barriers and horizontal assemblies shall be not less than that specified for fire walls in Table 706.4 of the *International Building Code*.

**Exception:** Where horizontal assemblies are used to limit the maximum allowable area, the required fire resistance rating of the horizontal assemblies shall be permitted to be reduced by 1 hour provided the height and number of stories increases allowed for an automatic sprinkler system by Section 504 of the *International Building Code* are not used for the buildings.

**4042.5.2 1011.6.2 Height and area for change to equal or lesser hazard category.**

When a change of occupancy classification is made to an equal or lesser hazard category as shown in Table 4042.5 1011.6, the height and area of the *existing building* shall be deemed acceptable.



**4042.5.3 1011.6.3 Fire barriers.**

When a change of occupancy classification is made to a higher hazard category as shown in Table 4042.5, fire barriers in separated mixed use buildings shall comply with the fire-resistance requirements of the *International Building Code*.

**Exception:** Where the fire barriers are required to have a 1-hour fire-resistance rating, existing wood lath and plaster in good condition or existing  $\frac{1}{2}$ -inch-thick (12.7 mm) gypsum wallboard shall be permitted.

**4042.6 1011.7 Exterior wall fire-resistance ratings.**

Hazard categories in regard to fire-resistance ratings of exterior walls shall be in accordance with Table 4042.6 1011.7.

**TABLE 4042.6 1011.7  
EXPOSURE OF EXTERIOR WALLS HAZARD CATEGORIES**

| RELATIVE HAZARD    | OCCUPANCY CLASSIFICATION  |
|--------------------|---------------------------|
| 1 (Highest Hazard) | H                         |
| 2                  | F-1, M <sup>a</sup> , S-1 |
| 3                  | A, B, E, I, R             |
| 4 (Lowest Hazard)  | F-2, S-2, U               |

a. Group M occupancy of 12,000 square feet (1114 m<sup>2</sup>) or less shall be relative hazard category 3.

**4042.6.1 1011.7.1 Exterior wall rating for change of occupancy classification to a higher hazard category.**

When a change of occupancy classification is made to a higher hazard category as shown in Table 4042.6 1011.7, exterior walls shall have fire resistance and exterior opening protectives as required by the *International Building Code*.

**Exception:** A 2-hour fire-resistance rating shall be allowed where the building does not exceed three stories in height and is classified as one of the following groups: A-2 and A-3 with an occupant load of less than 300, B, F, M or S.

**4042.6.2 1011.7.2 Exterior wall rating for change of occupancy classification to an equal or lesser hazard category.**

When a change of occupancy classification is made to an equal or lesser hazard category as shown in Table 4042.6 1011.7, existing exterior walls, including openings, shall be accepted.

### **~~4042.6.3~~ 1011.7.3 Opening protectives.**

Openings in exterior walls shall be protected as required by the *International Building Code*. Where openings in the exterior walls are required to be protected because of their distance from the lot line, the sum of the area of such openings shall not exceed 50 percent of the total area of the wall in each story.

#### **Exceptions:**

1. Where the *International Building Code* permits openings in excess of 50 percent.
2. Protected openings shall not be required in buildings of Group R occupancy that do not exceed three stories in height and that are located not less than 3 feet (914 mm) from the lot line.
3. ~~Where exterior~~ Exterior opening protectives are not required, where an automatic sprinkler system ~~throughout may be substituted for opening protection~~ has been installed throughout.
4. Exterior opening protectives are not required when the change of occupancy group is to an equal or lower hazard classification in accordance with Table ~~4042.6~~ 1011.7.

### **~~4042.7~~ 1011.8 Enclosure of vertical shafts.**

Enclosure of vertical shafts shall be in accordance with Sections ~~4042.7.1~~ 1011.8.1 through ~~4042.7.4~~ 1011.8.4.

#### **~~4042.7.4~~ 1011.8.1 Minimum requirements.**

Vertical shafts shall be designed to meet the *International Building Code* requirements for atriums or the requirements of this section.

**Exception:** Shafts for Group M occupancies in buildings that are less than 3,000 square feet (278 m<sup>2</sup>) or less per floor and three stories or less are not required to be enclosed.

#### **~~4042.7.2~~ 1011.8.2 Stairways.**

When a change of occupancy classification is made to a higher hazard category as shown in Table ~~4042.4~~ 1011.5, interior stairways shall be enclosed as required by the *International Building Code*.

#### **Exceptions:**

1. In other than Group I occupancies, an enclosure shall not be required for openings serving only one adjacent floor and that are not connected with corridors or stairways serving other floors.
2. Unenclosed existing stairways need not be enclosed in a continuous vertical shaft if each story is separated from other stories by 1-hour fire-resistance-rated construction or approved wired glass set in steel frames and all exit corridors are sprinklered. The openings between the corridor and the occupant space shall have at least one sprinkler head above the openings on the tenant side. The sprinkler system shall be permitted to be supplied from the domestic water supply systems,

provided the system is of adequate pressure, capacity, and sizing for the combined domestic and sprinkler requirements.

3. Existing penetrations of stairway enclosures shall be accepted if they are protected in accordance with the *International Building Code*.

#### **~~4042.7.3~~ 1011.8.3 Other vertical shafts.**

Interior vertical shafts other than stairways, including but not limited to elevator hoistways and service and utility shafts, shall be enclosed as required by the *International Building Code* when there is a change of use to a higher hazard category as specified in Table ~~4042.4~~ 1011.5.

#### **Exceptions:**

1. Existing 1-hour interior shaft enclosures shall be accepted where a higher rating is required.
2. Vertical openings, other than stairways, in buildings of other than Group I occupancy and connecting less than six stories shall not be required to be enclosed if the entire building is provided with an approved automatic sprinkler system.

#### **~~4042.7.4~~ 1011.8.4 Openings.**

All openings into existing fire resistance rated vertical shaft enclosures shall be protected by fire assemblies having a fire protection rating of not less than 1 hour and shall be maintained self-closing or shall be automatic-closing by actuation of a smoke detector. All other openings shall be fire protected in an approved manner. Existing fusible link-type automatic door-closing devices shall be permitted in all shafts except stairways if the fusible link rating does not exceed 135°F (57°C).

#### **~~4042.8~~ 1011.9 Dwelling unit separation.**

##### **~~4042.8.1~~ 1011.9.1 Townhouses.**

*Existing buildings* that establish new townhouse dwelling units shall comply with separation requirements of Section R302.2 of the *North Carolina Residential Code* and related subsections.

##### **~~4042.8.2~~ 1011.9.2 Two-family dwellings.**

*Existing buildings* that establish new detached two-family dwelling units shall comply with separation requirements of Section R302.3 of the *North Carolina Residential Code* and related subsections.

##### **~~4042.8.3~~ 1011.9.3 Group I-1, R-1, R-2 or R3.**

*Existing buildings* that establish new Group I-1, R-1, R-2 or R-3 dwelling or sleeping units shall comply with separation requirements of Section 420 of the *North Carolina Building Code*.

#### **1012.9 Accessibility.**

~~Existing buildings that undergo a change of group or occupancy classification shall comply with this section.~~

~~**Exception:** Type B dwelling or sleeping units required by Section 1107 of the *International Building Code* are not required to be provided in existing buildings and facilities undergoing a *change of occupancy* in conjunction with less than a Level 3 *alteration*.~~

#### **1012.9.1 Partial change in occupancy.**

~~Where a portion of the building is changed to a new occupancy classification, any *alteration* shall comply with Sections 806 and 906, as applicable.~~

#### **1012.9.2 Complete change of occupancy.**

~~Where an entire building undergoes a *change of occupancy*, it shall comply with Section 1012.9.1 and shall have all of the following accessible features:~~

- ~~1. At least one accessible building entrance.~~
- ~~2. At least one accessible route from an accessible building entrance to *primary function* areas.~~
- ~~3. Signage complying with Section 1111 of the *International Building Code*.~~
- ~~4. Accessible parking, where parking is provided.~~
- ~~5. At least one accessible passenger loading zone, where loading zones are provided.~~
- ~~6. At least one accessible route connecting accessible parking and accessible passenger loading zones to an accessible entrance.~~

~~Where it is *technically infeasible* to comply with the new construction standards for any of these requirements for a change of group or occupancy, the above items shall conform to the requirements to the maximum extent technically feasible.~~

~~**Exception:** The accessible features listed in Items 1 through 6 are not required for an accessible route to Type B units.~~

## **CHAPTER 11 ADDITIONS**

### **SECTION 1101 GENERAL**

### **1101.1 Scope.**

An *addition* to a building or structure shall comply with the *International Codes* as adopted for new construction without requiring the *existing building* or structure to comply with any requirements of those codes or of these provisions, except as required by this chapter. Where an *addition* impacts the *existing building* or structure, that portion shall comply with this code.

### **1101.2 Creation or extension of nonconformity.**

An *addition* shall not create or extend any nonconformity in the *existing building* to which the *addition* is being made with regard to accessibility, structural strength, fire safety, means of egress, or the capacity of mechanical, plumbing, or electrical systems.

### **1101.3 Other work.**

Any *repair* or *alteration* work within an *existing building* to which an *addition* is being made shall comply with the applicable requirements for the work as classified in Chapter ~~5~~6.

### **1101.4 Enhanced classroom acoustics. Deleted.**

## **SECTION 1102 HEIGHTS AND AREAS**

### **1102.1 Height limitations.**

No *addition* shall increase the height of an *existing building* beyond that permitted under the applicable provisions of Chapter 5 of the *International Building Code* for new buildings.

### **1102.2 Area limitations.**

No *addition* shall increase the area of an *existing building* beyond that permitted under the applicable provisions of Chapter 5 of the *International Building Code* for new buildings unless fire separation as required by the *International Building Code* is provided.

**Exception:** In-filling of floor openings and nonoccupiable appendages such as elevator and exit stairway shafts shall be permitted beyond that permitted by the *International Building Code*.

### **1102.3 Fire protection systems.**

Existing fire areas increased by the *addition* shall comply with Chapter 9 of the *International Building Code*.

**Exception:** This requirement shall not apply to increases to the allowable fire area of 5 percent or less.

## **SECTION 1103 STRUCTURAL**

### **~~[BS] 1103.1 Compliance with the International Building Code.~~**

~~*Additions to existing buildings* or structures are new construction and shall comply with the *International Building Code*.~~

**[BS] 1103.2 1103.1 Additional gravity loads.**

~~Existing structural elements supporting any additional gravity loads as a result of additions shall comply with the *International Building Code*.~~

Any existing gravity load-carrying structural element for which an *addition* and its related *alterations* cause an increase in design dead, live or snow load, including snow drift effects, of more than 5 10 percent shall be replaced or altered as needed to carry the gravity loads required by the *International Building Code* for new structures. Any existing gravity load-carrying structural element whose gravity load-carrying capacity is decreased as part of the *addition* and its related *alterations* shall be considered to be an altered element subject to the requirements of Section 805.2. Any existing element that will form part of the lateral load path for any part of the *addition* shall be considered to be an existing lateral load-carrying structural element subject to the requirements of Section 1103.3.

~~Exceptions~~ **Exception:**

- ~~1. Structural elements whose stress is not increased by more than 5 10 percent.~~
2. Buildings of Group R occupancy with not more than five dwelling units or sleeping units used solely for residential purposes where the *existing building* and the *addition* comply with the conventional lightframe construction methods of the *International Building Code* or the provisions of the *International Residential Code*.

**[BS] 1103.3 1103.2 Lateral force-resisting system.**

~~The lateral force-resisting system of *existing buildings* to which additions are made shall comply with Sections 1103.3.1, 1103.3.2 and 1103.3.3.~~

Where the *addition* is structurally independent of the *existing structure*, existing lateral load-carrying structural elements shall be permitted to remain unaltered. Where the *addition* is not structurally independent of the *existing structure*, the *existing structure* and its *addition* acting together as a single structure shall meet the requirements of Sections 1609 and 1613 of the *International Building Code* using full seismic forces.

**Exceptions:**

1. Buildings of Group R occupancy with not more than five dwelling or sleeping units used solely for residential purposes where the *existing building* and the *addition* comply with the conventional light-frame construction methods of the *International Building Code* or the provisions of the *International Residential Code*.

Any existing lateral load-carrying structural element whose demand-capacity ratio with the addition considered is not more than 10 percent greater than its demand-capacity ratio with the addition ignored shall be permitted to remain unaltered. For purposes of this exception, comparisons of demand-capacity

~~ratios and calculation of design lateral loads, forces and capacities shall account for the cumulative effects of additions and alterations since original construction. calculating demand-capacity ratios, the demand shall consider applicable load combinations with design lateral loads or forces in accordance with Sections 1609 and 1613 of the *International Building Code*. For purposes of calculating demand-capacity ratios, the demand shall consider applicable load combinations involving *International Building Code* level seismic forces in accordance with Section 301.1.4.1. this exception, comparisons of demand-capacity ratios and calculation of design lateral loads, forces and capacities shall account for the cumulative effects of *additions* and *alterations* since original construction.~~

**~~[BS] 1103.3.1 Vertical addition.~~**

~~Any element of the lateral force-resisting system of an *existing building* subjected to an increase in vertical or lateral loads from the vertical *addition* shall comply with the *International Building Code* wind provisions and the *International Building Code* level seismic forces specified in Section 301.1.4.1 of this code.~~

**~~[BS] 1103.3.2 Horizontal addition.~~**

~~Where horizontal *additions* are structurally connected to an existing structure, all lateral force-resisting elements of the existing structure affected by such *addition* shall comply with the *International Building Code* wind provisions and the IBC level seismic forces specified in Section 301.1.4.1 of this code.~~

**~~[BS] 1103.3.3 Voluntary addition of structural elements to improve the lateral force-resisting system.~~**

~~Voluntary addition of structural elements to improve the lateral force-resisting system of an *existing building* shall comply with Section 807.6.~~

**~~[BS] 1103.4 Snow drift loads.~~**

~~Any structural element of an *existing building* subjected to additional loads from the effects of snow drift as a result of an *addition* shall comply with the *International Building Code*.~~

**~~Exceptions:~~**

- ~~1. Structural elements whose stress is not increased by more than **5** 10 percent.~~
- ~~2. Buildings of Group R occupancy used solely for residential purposes where the *existing building* and the *addition* comply with the conventional lightframe construction methods of the *International Building Code* or the provisions of the *International Residential Code*.~~

**~~[BS] 1103.5 1103.3 Flood hazard areas.~~**

~~*Additions* and *foundations* in *flood hazard areas* shall comply with the following requirements:~~

1. For horizontal *additions* that are structurally interconnected to the *existing building*:
  - 1.1. If the *addition* and all other proposed work, when combined, constitute *substantial improvement*, the *existing building* and the *addition* shall comply with Section 1612 of the *International Building Code*, or Section R322 of the *International Residential Code*, as applicable.

- 1.2. If the *addition* constitutes *substantial improvement*, the *existing building* and the *addition* shall comply with Section 1612 of the *International Building Code*, or Section R322 of the *International Residential Code*, as applicable.
2. For horizontal *additions* that are not structurally interconnected to the *existing building*:
  - 2.1. The *addition* shall comply with Section 1612 of the *International Building Code*, or Section R322 of the *International Residential Code*, as applicable.
  - 2.2. If the *addition* and all other proposed work, when combined, constitute *substantial improvement*, the *existing building* and the *addition* shall comply with Section 1612 of the *International Building Code*, or Section R322 of the *International Residential Code*, as applicable.
3. For vertical *additions* and all other proposed work that, when combined, constitute *substantial improvement*, the *existing building* shall comply with Section 1612 of the *International Building Code*, or Section R322 of the *International Residential Code*, as applicable.
4. For a raised or extended foundation, if the foundation work and all other proposed work, when combined, constitute *substantial improvement*, the *existing building* shall comply with Section 1612 of the *International Building Code*, or Section R322 of the *International Residential Code*, as applicable.
5. For a new foundation or replacement foundation, the foundation shall comply with Section 1612 of the *International Building Code* or Section R322 of the *International Residential Code*, as applicable.

## **SECTION 1104 SMOKE AND CARBON MONOXIDE ALARMS**

### **~~1104.1 Smoke alarms in existing portions of a building.~~**

~~Where an *addition* is made to a building or structure of a Group R or I-1 occupancy, the *existing building* shall be provided with smoke alarms as required by Section 907.2.11 of the *North Carolina Building Code* or Section R314 of the *International Residential Code* as applicable.~~

### **~~1104.2 Carbon monoxide alarms in existing portions of a building.~~**

~~Where an *addition* is made to a building or structure of a Group I-1, I-2, I-4 or R occupancies, or classrooms are added in Group E occupancies, the *existing building* shall be provided with carbon monoxide alarms in accordance with Section 915 of the *North Carolina Building Code* or Section R315 of the *North Carolina Residential Code*, except that the carbon monoxide alarms shall be allowed to be solely battery operated.~~

## **SECTION 1105 ACCESSIBILITY**



#### **~~1105.1~~ Minimum requirements.**

~~Accessibility provisions for new construction shall apply to additions. An addition that affects the accessibility to, an area of *primary function* or contains an area of, *primary function* shall comply with the requirements of Sections 806 and 906, as applicable.~~

#### **~~1105.2~~ Accessible dwelling units and sleeping units.**

~~Where Group I-1, I-2, I-3, R-1, R-2 or R-4 dwelling or sleeping units are being added, the requirements of Section 1107 of the *International Building Code* for accessible units apply only to the quantity of spaces being added.~~

#### **~~1105.3~~ Type A dwelling or sleeping units.**

~~Where 11 or more Group R-2 dwelling or sleeping units are being added, the requirements of Section 1107 of the *International Building Code* for Type A units and Chapter 9 of the *International Building Code* for visible alarms apply only to the quantity of the spaces being added.~~

#### **~~1105.4~~ Type B dwelling or sleeping units.**

~~Where four or more Group I-1, I-2, R-1, R-2, R-3 or R-4 dwelling or sleeping units are being added, the requirements of Section 1107 of the *International Building Code* for Type B units and Chapter 9 of the *International Building Code* for visible alarms apply only to the quantity of spaces being added.~~

## **SECTION 1106 1104 ENERGY CONSERVATION**

#### **1106.1 Minimum requirements.**

~~Additions to existing buildings shall conform to the energy requirements of the *International Energy Conservation Code* or *International Residential Code* as they relate to new construction without requiring the unaltered portion of the existing building or building system to comply with the *North Carolina Energy Conservation Code*.~~

## **CHAPTER 12 HISTORIC BUILDINGS**

### **SECTION 1201 GENERAL**

#### **1201.1 Scope.**

~~It is the intent of this chapter.~~ This chapter is intended to provide means for the preservation of *historic buildings*. Historical buildings shall comply with the provisions of this chapter relating to their *repair*, *alteration*, relocation and *change of occupancy*.

#### **[BS] 1201.2 Report.**

A *historic building* undergoing *repair*, *alteration*, or *change of occupancy* shall be investigated and evaluated. If it is intended that the building meet the requirements of this chapter, a written report shall be prepared and filed with the *code official* by a registered design professional when such a report is necessary in the opinion of the ~~2018~~ 2024 North Carolina Existing Building Code

*code official*. Such report shall be in accordance with Chapter 1 and shall identify each required safety feature that is in compliance with this chapter and where compliance with other chapters of these provisions would be damaging to the contributing historic features. For buildings assigned to Seismic Design Category D, E or F, a structural evaluation describing, at a minimum, the vertical and horizontal elements of the lateral force-resisting system and any strengths or weaknesses therein shall be prepared. Additionally, the report shall describe each feature that is not in compliance with these provisions and shall demonstrate how the intent of these provisions is complied with in providing an equivalent level of safety.

### **1201.3 Special occupancy exceptions—museums.**

When a building in Group R-3 is also used for Group A, B, or M purposes such as museum tours, exhibits, and other public assembly activities, or for museums less than 3,000 square feet (279 m<sup>2</sup>), the *code official* may determine that the occupancy is Group B when life-safety conditions can be demonstrated in accordance with Section 1201.2. Adequate means of egress in such buildings, which may include a means of maintaining doors in an open position to permit egress, a limit on building occupancy to an occupant load permitted by the means of egress capacity, a limit on occupancy of certain areas or floors, or supervision by a person knowledgeable in the emergency exiting procedures, shall be provided.

### **[BS] 1201.4 Flood hazard areas.**

In *flood hazard areas*, if all proposed work, including repairs, work required because of a *change of occupancy*, and *alterations*, constitutes *substantial improvement*, then the *existing building* shall comply with Section 1612 of the *International Building Code*, or Section R322 of the *International Residential Code*, as applicable.

**Exception:** If an *historic building* will continue to be an *historic building* after the proposed work is completed, then the proposed work is not considered a *substantial improvement*. For the purposes of this exception, an *historic building* is:

1. Listed or preliminarily determined to be eligible for listing in the National Register of Historic Places;
2. Determined by the Secretary of the U.S. Department of Interior to contribute to the historical significance of a registered historic district or a district preliminarily determined to qualify as a historic district; or
3. Designated as historic under a state or local historic preservation program that is approved by the Department of Interior.

**1201.5 Unsafe conditions.** Conditions determined by the *code official* to be *unsafe* shall be remedied. Work shall not be required beyond what is required to remedy the *unsafe* conditions.

### **~~1201.5~~ 1201.6 Ceiling height.**

Existing ceiling heights shall be permitted to remain.

## SECTION 1202 REPAIRS

### 1202.1 General.

Repairs to any portion of an *historic building* or structure shall be permitted with original or like materials and original methods of construction, subject to the provisions of this chapter. Hazardous materials, such as asbestos and lead-based paint, shall not be used where the code for new construction would not permit their use in buildings of similar occupancy, purpose and location.

### ~~1202.2 Unsafe conditions.~~

~~Conditions determined by the *code official* to be *unsafe* shall be remedied. No work shall be required beyond what is required to remedy the *unsafe* conditions.~~

### ~~1202.3 Relocated buildings.~~

~~Foundations of relocated *historic buildings* and structures shall comply with the *International Building Code*. Relocated *historic buildings* shall otherwise be considered an *historic building* for the purposes of this code. Relocated *historic buildings* and structures shall be sited so that exterior wall and opening requirements comply with the *International Building Code* or with the compliance alternatives of this code.~~

### 1202.4 1202.2 Replacement.

Replacement of existing or missing features using original materials shall be permitted. Partial replacement for repairs that match the original in configuration, height, and size shall be permitted.

Replacement glazing in hazardous locations shall comply with the safety glazing requirements of Chapter 24 of the *International Building Code*.

**Exception:** Glass block walls, louvered windows, and jalousies repaired with like materials.

#### ~~1202.4.1~~ 1202.2.1 Wind-borne debris protection.

Replacement of window units shall require compliance with Section 1609.1.2 of the *North Carolina Building Code* or Section R609.6 of the *North Carolina Residential Code*. Replacement of individual glass panes or sashes shall not require compliance with Section 1609.1.2 of the *North Carolina Building Code* or R609.6 of the *North Carolina Residential Code*.

## SECTION 1203 FIRE SAFETY

### 1203.1 Scope.

*Historic buildings* undergoing *alterations*, *changes of occupancy*, or that are moved shall comply with Section 1203.

### 1203.2 General.

Every *historic building* that does not conform to the construction requirements specified in this code for the occupancy or use and that constitutes a distinct fire hazard as identified by the *code official* shall be provided  
2018 2024 North Carolina Existing Building Code

with an approved automatic fire-extinguishing system as determined appropriate by the *code official*. However, an automatic fire-extinguishing system shall not be used to substitute for, or act as an alternative to, the required number of exits from any *facility*.

### **1203.3 Means of egress.**

Existing door openings and corridor and stairway widths less than those specified elsewhere in this code may be approved, provided that, in the opinion of the *code official*, there is sufficient width and height for a person to pass through the opening or traverse the means of egress. When approved by the *code official*, the front or main exit doors need not swing in the direction of the path of exit travel, provided that other approved means of egress having sufficient capacity to serve the total occupant load are provided.

### **1203.4 Transoms.**

In fully sprinklered buildings of Group R-1, R-2 or R-3 occupancy, existing transoms in corridors and other fire-resistance-rated walls may be maintained if fixed in the closed position. A sprinkler shall be installed on each side of the transom.

### **1203.5 Interior finishes.**

The existing finishes of walls and ceilings shall be accepted when it is demonstrated that they are the historic finishes.

### **1203.6 Stairway enclosure.**

In buildings of three stories or less, exit enclosure construction shall limit the spread of smoke by the use of tight-fitting doors and solid elements. Such elements are not required to have a fire-resistance rating.

### **1203.7 One-hour fire-resistant assemblies.**

Where 1-hour fire-resistance-rated construction is required by these provisions, it need not be provided, regardless of construction or occupancy, where the existing wall and ceiling finish is wood or metal lath and plaster.

### **1203.8 Glazing in fire-resistance-rated systems.**

Historic glazing materials are permitted in interior walls required to have a 1-hour fire-resistance rating where the opening is provided with approved smoke seals and the area affected is provided with an automatic sprinkler system.

### **1203.9 Stairway railings.**

Grand stairways shall be accepted without complying with the handrail and guard requirements. Existing handrails and guards at all stairways shall be permitted to remain, provided they are not structurally *dangerous*.

### **1203.10 Guards.**

Guards shall comply with Sections 1203.10.1 and 1203.10.2.

#### **1203.10.1 Height.**

Existing guards shall comply with the requirements of Section ~~604~~ 404.

#### **1203.10.2 Guard openings.**

The spacing between existing intermediate railings or openings in existing ornamental patterns shall be

accepted. Missing elements or members of a guard may be replaced in a manner that will preserve the historic appearance of the building or structure.

**1203.11 Exit signs.**

Where exit sign or egress path marking location would damage the historic character of the building, alternative exit signs are permitted with approval of the *code official*. Alternative signs shall identify the exits and egress path.

**1203.12 Automatic fire-extinguishing systems.** Deleted.

~~**1203.13 Smoke and carbon monoxide alarms.**~~

~~Smoke and carbon monoxide alarms shall be provided and installed in accordance with Section 804.4.~~

**SECTION 1204  
ALTERATIONS**

~~**1204.1 Accessibility requirements.**~~

~~The provisions of Sections 806 and 906, as applicable, shall apply to facilities designated as historic structures that undergo *alterations*, unless *technically infeasible*. Where compliance with the requirements for accessible routes, entrances or toilet rooms would threaten or destroy the historic significance of the building or *facility*, as determined by the *code official*, the alternative requirements of Sections 1204.1.1 through 1204.1.4 for that element shall be permitted.~~

~~**Exception:** Type B dwelling or sleeping units required by Section 1107 of the *International Building Code* are not required to be provided in historical buildings.~~

~~**1204.1.1 Site arrival points.**~~

~~At least one accessible route from a site arrival point to an *accessible* entrance shall be provided.~~

~~**1204.1.2 Multilevel buildings and facilities.**~~

~~An accessible route from an accessible entrance to public spaces on the level of the accessible entrance shall be provided.~~

~~**1204.1.3 Entrances.**~~

~~At least one main entrance shall be accessible.~~

**Exceptions:**

- ~~1. If a main entrance cannot be made accessible, an accessible nonpublic entrance that is unlocked while the building is occupied shall be provided; or~~

~~2. If a main entrance cannot be made accessible, a locked accessible entrance with a notification system or remote monitoring shall be provided.~~

~~**1204.1.4 Toilet and bathing facilities.**~~

~~Where toilet rooms are provided, at least one accessible family or assisted-use toilet room complying with Section 1109.2.1 of the *International Building Code* shall be provided.~~

## **SECTION 1205 CHANGE OF OCCUPANCY**

~~**1205.1 1204.1 General.**~~

~~*Historic buildings* undergoing a *change of occupancy* shall comply with the applicable provisions of Chapter 10, except as specifically permitted in this chapter. When Chapter 10 requires compliance with specific requirements of Chapter 7, Chapter 8 or Chapter 9 and when those requirements are subject to the exceptions in Section 1202, the same exceptions shall apply to this section.~~

~~**1205.2 1204.2 Building area.**~~

~~The allowable floor area for *historic buildings* undergoing a *change of occupancy* shall be permitted to exceed by 20 percent the allowable areas specified in Chapter 5 of the *International Building Code*.~~

~~**1205.3 1204.3 Location on property.**~~

~~Historic structures undergoing a change of use to a higher hazard category in accordance with Section 1012.6 may use alternative methods to comply with the fire-resistance and exterior opening protective requirements. Such alternatives shall comply with Section 1201.2.~~

~~**1205.4 1204.4 Occupancy separation.**~~

~~Required occupancy separations of 1 hour may be omitted when the building is provided with an approved automatic sprinkler system throughout.~~

~~**1205.5 1204.5 Roof covering.**~~

~~Regardless of occupancy or use group, roof-covering materials not less than Class C, when tested in accordance with ASTM E 108 or UL 790, shall be permitted where a fire-retardant roof covering is required.~~

~~**1205.6 1204.6 Means of egress.**~~

~~Existing door openings and corridor and stairway widths less than those that would be acceptable for nonhistoric buildings under these provisions shall be approved, provided that, in the opinion of the *code official*, there is sufficient width and height for a person to pass through the opening or traverse the exit and that the capacity of the exit system is adequate for the occupant load, or where other operational controls to limit occupancy are approved by the *code official*.~~

~~**1205.7 1204.7 Door swing.**~~

~~When approved by the *code official*, existing front doors need not swing in the direction of exit travel, provided that other approved exits having sufficient capacity to serve the total occupant load are provided.~~

#### **4205.8 1204.8 Transoms.**

In corridor walls required by these provisions to be fire-resistance rated, existing transoms may be maintained if fixed in the closed position, and fixed wired glass set in a steel frame or other approved glazing shall be installed on one side of the transom.

**Exception:** Transoms conforming to Section 1203.4 shall be accepted.

#### **4205.9 1204.9 Finishes.**

Where interior finish materials are required to have a flame spread index of Class C or better, when tested in accordance with ASTM E 84 or UL 723, existing nonconforming materials shall be surfaced with approved fire-retardant paint or finish.

**Exception:** Existing nonconforming materials need not be surfaced with an approved fire-retardant paint or finish where the building is equipped throughout with an automatic sprinkler system installed in accordance with the *International Building Code* and the nonconforming materials can be substantiated as being historic in character.

#### **4205.10 1204.10 One-hour fire-resistant assemblies.**

Where 1-hour fire-resistance-rated construction is required by these provisions, it need not be provided, regardless of construction or occupancy, where the existing wall and ceiling finish is wood lath and plaster.

#### **4205.11 1204.11 Stairways and guards.**

Existing stairways shall comply with the requirements of these provisions. The *code official* shall grant alternatives for stairways and guards if alternative stairways are found to be acceptable or are judged to meet the intent of these provisions. Existing stairways shall comply with Section 1203.

**Exception:** For buildings less than 3,000 square feet (279 m<sup>2</sup>), existing conditions are permitted to remain at all stairways and guards.

#### **4205.12 1204.12 Exit signs.**

The *code official* may accept alternative exit sign locations where such signs would damage the historic character of the building or structure. Such signs shall identify the exits and exit path.

#### **[BS] 4205.13 1204.13 Exit stair live load.**

Existing historic stairways in buildings changed to a Group R-1 or R-2 occupancy shall be accepted where it can be shown that the stairway can support a 75-pounds-per-square-foot (366 kg/m<sup>2</sup>) live load.

#### **4205.14 1204.14 Natural light.**

When it is determined by the *code official* that compliance with the natural light requirements of Section 1011.1 will lead to loss of historic character or historic materials in the building, the existing level of natural lighting shall be considered acceptable.

#### **~~1205.15~~ Accessibility requirements.**

~~The provisions of Section 1012.8 shall apply to facilities designated as historic structures that undergo a *change of occupancy*, unless *technically infeasible*. Where compliance with the requirements for accessible routes, ramps, entrances, or toilet rooms would threaten or destroy the historic significance of the building or facility, as determined by the authority having jurisdiction, the alternative requirements of Sections 1204.1.1 through 1204.1.4 for those elements shall be permitted~~

**Exception:** Type B dwelling or sleeping units required by Section 1107 of the *International Building Code* are not required to be provided in historical buildings.

## **SECTION ~~1206~~ 1205 STRUCTURAL**

### **[BS] ~~1206.4~~ 1205.1 General.**

*Historic buildings* shall comply with the applicable structural provisions for the work as classified in Chapter 4 or 5.

#### **~~Exception:~~ Exceptions:**

1. The *code official* shall be authorized to accept existing floors and approve operational controls that limit the live load on any such floor.
2. *Repair of substantial structural damage* is not required to comply with Sections 405.2.3 and 405.2.4. *Substantial structural damage* shall be repaired in accordance with Section 405.2.1.

### **[BS] ~~1206.2~~ 1205.2 Dangerous conditions.**

Conditions determined by the *code official* to be *dangerous* shall be remedied. No work shall be required beyond what is required to remedy the *dangerous* condition.

## **SECTION 1206 RELOCATED BUILDINGS**

**1206.1 Relocated buildings.** Foundations of relocated *historic buildings* and structures shall comply with the *International Building Code*. Relocated *historic buildings* shall otherwise be considered a *historic building* for the purposes of this code. Relocated *historic buildings* and structures shall be sited so that exterior wall and opening requirements comply with the *International Building Code* or with the compliance alternatives of this code.

## **CHAPTER 13**



# ~~RELOCATED OR MOVED BUILDINGS~~

## ~~SECTION 1301 GENERAL~~

### ~~1301.1 Scope.~~

~~This chapter provides requirements for relocated or moved structures~~

### ~~1301.2 Conformance.~~

~~The building shall be safe for human occupancy as determined by the *International Fire Code*. Any repair, alteration, or change of occupancy undertaken within the moved structure shall comply with the requirements of this code applicable to the work being performed. Any field-fabricated elements shall comply with the requirements of the *International Building Code* or the *International Residential Code* as applicable.~~

## ~~SECTION 1302 REQUIREMENTS~~

### ~~1302.1 Location on the lot.~~

~~The building shall be located on the lot in accordance with the requirements of the *International Building Code* or the *International Residential Code* as applicable.~~

### ~~[BS] 1302.2 Foundation.~~

~~The foundation system of relocated buildings shall comply with the *International Building Code* or the *International Residential Code* as applicable.~~

#### ~~[BS] 1302.2.1 Connection to the foundation.~~

~~The connection of the relocated building to the foundation shall comply with the *International Building Code* or the *International Residential Code* as applicable.~~

### ~~[BS] 1302.3 Wind loads.~~

~~Buildings shall comply with *International Building Code* or *International Residential Code* wind provisions as applicable.~~

#### ~~Exceptions:~~

- ~~1. Detached one- and two-family dwellings and Group U occupancies where wind loads at the new location are not higher than those at the previous location.~~
- ~~2. Structural elements whose stress is not increased by more than 10 percent.~~

#### **~~[BS] 1302.4 Seismic loads.~~**

~~Buildings shall comply with *International Building Code* or *International Residential Code* seismic provisions at the new location as applicable.~~

#### **~~Exceptions:~~**

- ~~1. Structures in Seismic Design Categories A and B and detached one- and two-family dwellings in Seismic Design Categories A, B and C where the seismic loads at the new location are not higher than those at the previous location.~~
- ~~2. Structural elements whose stress is not increased by more than 10 percent.~~

#### **~~[BS] 1302.5 Snow loads.~~**

~~Structures shall comply with *International Building Code* or *International Residential Code* snow loads as applicable where snow loads at the new location are higher than those at the previous location.~~

~~**Exception:** Structural elements whose stress is not increased by more than 5 percent.~~

#### **~~[BS] 1302.6 Flood hazard areas.~~**

~~If relocated or moved into a flood hazard area, structures shall comply with Section 1612 of the *International Building Code*, or Section R322 of the *International Residential Code*, as applicable.~~

#### **~~[BS] 1302.7 Required inspection and repairs.~~**

~~The code official shall be authorized to inspect, or to require approved professionals to inspect at the expense of the owner, the various structural parts of a relocated building to verify that structural components and connections have not sustained structural damage. Any repairs required by the code official as a result of such inspection shall be made prior to the final approval.~~

## **PERFORMANCE COMPLIANCE METHODS**

### **GENERAL**

**1301.1 Scope.** The provisions of this chapter shall apply to the *alteration, addition and change of occupancy of existing structures*, including historic structures, as referenced in Section 301.3.3. The provisions of this chapter are intended to maintain or increase the current degree of public safety, health and general welfare in *existing buildings* while permitting, *alteration, addition and change of occupancy* without requiring full compliance with Chapters 6 through 12, except where compliance with the prescriptive method of Chapter 5 or the work area method of other provisions of this code is specifically required in this chapter.

**1301.1.1 Compliance with other methods.** *Alterations, additions and changes of occupancy to existing structures shall comply with the provisions of this chapter or with one of the methods provided in Section 301.3.*

**1301.2 Applicability.** *Existing buildings in which there is work involving additions, alterations or changes of occupancy shall be made to conform to the requirements of this chapter or the provisions of Chapters 6 through 12. The provisions of Sections 1301.2.1 through 1301.2.6 shall apply to existing occupancies that will continue to be, or are proposed to be, in Groups A, B, E, F, I-2, M, R and S. These provisions shall also apply to Group U occupancies where such occupancies are undergoing a change of occupancy or a partial change in occupancy with separations in accordance with Section 1301.2.2. These provisions shall not apply to buildings with occupancies in Group H, I-1, I-3 or I-4.*

**1301.2.1 Change in occupancy.** *Where an existing building is changed to a new occupancy classification and this section is applicable, the provisions of this section for the new occupancy shall be used to determine compliance with this code.*

**1301.2.2 Partial change in occupancy.** *Where a portion of the building is changed to a new occupancy classification and that portion is separated from the remainder of the building with fire barrier or horizontal assemblies having a fire-resistance rating as required by Table 508.4 of the *International Building Code* or Section R302 of the *International Residential Code* for the separate occupancies, or with approved compliance alternatives, the portion changed shall be made to conform to the provisions of this section. Only the portion separated shall be required to be evaluated for compliance.*

*Where a portion of the building is changed to a new occupancy classification and that portion is not separated from the remainder of the building with fire barriers or horizontal assemblies having a fire-resistance rating as required by Table 508.4 of the *International Building Code* or Section R302 of the *International Residential Code* for the separate occupancies, or with approved compliance alternatives, the provisions of this section which apply to each occupancy shall apply to the entire building. Where there are conflicting provisions, those requirements which secure the greater public safety shall apply to the entire building or structure.*

**1301.2.3 Additions.** *Additions to existing buildings shall comply with the requirements of the *International Building Code* or the *International Residential Code* for new construction. The combined height and area of the existing building and the new addition shall not exceed the height and area allowed by Chapter 5 of the *International Building Code*. Where a fire wall that complies with Section 706 of the *International Building Code* is provided between the addition and the existing building, the addition shall be considered a separate building.*

**1301.2.4 Alterations.** *An existing building or portion thereof shall not be altered in such a manner that results in the building being less safe or sanitary than such building is currently.*

**Exception:** *Where the current level of safety or sanitation is proposed to be reduced, the portion altered shall conform to the requirements of the *International Building Code*.*

**1301.2.5 Escalators.** *Where escalators are provided in below-grade transportation stations, existing and new escalators shall be permitted to have a clear width of less than 32 inches (815 mm).*

**1301.2.6 Plumbing fixtures.** *Plumbing fixtures shall be provided in accordance with Section 1009 for a change of occupancy and Section 808 for alterations. Plumbing fixtures for additions shall be in accordance with the *International Plumbing Code*.*

**1301.2.7 Occupant load increase.** *Where the existing occupant load is increased by more than 20 percent or in Group A occupancies where the occupant load is greater than 300, compliance with this chapter is not permitted. Compliance with other methods in this code shall be permitted.*

**1301.3 Acceptance.** *For repairs, alterations, additions and changes of occupancy to existing buildings that are evaluated in accordance with this section, compliance with this section shall be accepted by the code official.*

**1301.3.1 Hazards.** *Where the code official determines that an unsafe condition exists as provided for in Section 115, such unsafe condition shall be abated in accordance with Section 115.*

**1301.3.2 Compliance with other codes.** Buildings that are evaluated in accordance with this section shall comply with the *International Fire Code* and *International Property Maintenance Code*.

**[BS] 1301.3.3 Compliance with flood hazard provisions.** In *flood hazard areas*, buildings that are evaluated in accordance with this section shall comply with Section 1612 of the *International Building Code*, or Section R322 of the *International Residential Code*, as applicable, if the work covered by this section constitutes *substantial improvement*.

**1301.4 Investigation and evaluation.** For proposed work covered by this chapter, the building owner shall cause the *existing building* to be investigated and evaluated in accordance with the provisions of Sections 1301.4 through 1301.9.

**[BS] 1301.4.1 Structural analysis.** The owner shall have a structural analysis of the *existing building* made to determine adequacy of structural systems for the proposed *alteration, addition or change of occupancy*. The analysis shall demonstrate that the building with the work completed is capable of resisting the loads specified in Chapter 16 of the *International Building Code*.

**1301.4.2 Submittal.** The results of the investigation and evaluation as required in Section 1301.4, along with proposed compliance alternatives, shall be submitted to the *code official*.

**1301.4.3 Determination of compliance.** The *code official* shall determine whether the *existing building*, with the proposed *addition, alteration or change of occupancy*, complies with the provisions of this section in accordance with the evaluation process in Sections 1301.5 through 1301.9.

**1301.5 Evaluation.** The evaluation shall be composed of three categories: fire safety, means of egress and general safety, as defined in Sections 1301.5.1 through 1301.5.3.

**1301.5.1 Fire safety.** Included within the fire safety category are the structural fire resistance, automatic fire detection, fire alarm, automatic sprinkler system and fire suppression system features of the *facility*.

**1301.5.2 Means of egress.** Included within the means of egress category are the configuration, characteristics and support features for means of egress in the *facility*.

**1301.5.3 General safety.** Included within the general safety category are the fire safety parameters and the means of egress parameters.

**1301.6 Evaluation process.** The evaluation process specified herein shall be followed in its entirety to evaluate *existing buildings* in Groups A, B, E, F, M, R, S and U. For *existing buildings* in Group I-2, the evaluation process specified herein shall be followed and applied to each and every individual smoke compartment. Table 1301.7 shall be utilized for tabulating the results of the evaluation. References to other sections of this code or other codes indicate that compliance with those sections is required in order to gain credit in the evaluation herein outlined. In applying this section to a building with mixed occupancies, where the separation between the mixed occupancies does not qualify for any category indicated in Section 1301.6.16, the score for each occupancy shall be determined, and the lower score determined for each section of the evaluation process shall apply to the entire building or to each smoke compartment for Group I-2 occupancies.

Where the separation between the mixed occupancies qualifies for any category indicated in Section 1301.6.16, the score for each occupancy shall apply to each portion or smoke compartment of the building based on the occupancy of the space.

**1301.6.1 Building height and number of stories.** The value for building height and number of stories shall be the lesser value determined by the formula in Section 1301.6.1.1. Section 504 of the *International Building Code* shall be used to determine the allowable height and number of stories of the building. Subtract the actual building height from the allowable height and divide by  $12\frac{1}{2}$  feet (3810 mm). Enter the height value and its sign (positive or negative) in Table 1301.7 under Safety Parameter 1301.6.1, Building Height, for fire safety, means of egress and general safety. The maximum score for a building shall be 10.

**1301.6.1.1 Height formula.** The following formulas shall be used in computing the building height value.

$$\text{Height value, feet} = \frac{(AH) - (EBH)}{12.5} \times CF$$

**(Equation 13-1)**

$$\text{Height value, stories} = (AS - EBS) \times CF$$

**(Equation 13-2)**

where:

AH = Allowable height in feet (mm) from Section 504 of the *International Building Code*.

EBH = Existing building height in feet (mm).

AS = Allowable height in stories from Section 504 of the *International Building Code*.

EBS = Existing building height in stories.

CF = 1 if (AH) – (EBH) is positive.

CF = Construction-type factor shown in Table 1301.6.6(2) if (AH) – (EBH) is negative.

**Note:** Where mixed occupancies are separated and individually evaluated as indicated in Section 1301.6, the values AH, AS, EBH and EBS shall be based on the height of the occupancy being evaluated.

**1301.6.2 Building area.** The value for building area shall be determined by the formula in Section 1301.6.2.2. Section 506 of the *International Building Code* and the formula in Section 1301.6.2.1 shall be used to determine the allowable area of the building. Enter the area value and its sign (positive or negative) in Table 1301.7 under Safety Parameter 1301.6.2, Building Area, for fire safety, means of egress and general safety. In determining the area value, the maximum permitted positive value for area is 50 percent of the fire safety score as listed in Table 1301.8, Mandatory Safety Scores. Group I-2 occupancies shall be scored zero.

**1301.6.2.1 Allowable area formula.** The following formula shall be used in computing allowable area:

$$A_a = A_t + (NS \times I_f) \quad \text{(Equation 13-3)}$$

where:

A<sub>a</sub> = Allowable building area per story (square feet).

A<sub>t</sub> = Tabular allowable area factor (NS, S1, S13R, or SM value, as applicable) in accordance with Table 506.2 of the *International Building Code*.

NS = Tabular allowable area factor in accordance with Table 506.2 of the *International Building Code* for a nonsprinklered building (regardless of whether the building is sprinklered).

I<sub>f</sub> = Area factor increase due to frontage as calculated in accordance with Section 506.3 of the *International Building Code*.

**1301.6.2.2 Area formula.** The following formulas shall be used in computing the area value. Equation 13-4 shall be used for a single occupancy buildings and Equation 13-5 shall be used for multiple occupancy buildings. Determine the area value for each occupancy floor area on a floor-by-floor basis. For multiple occupancy, buildings with the minimum area value of the set of values obtained for the particular occupancy shall be used as the area value for that occupancy.

For single occupancy buildings:

$$\text{Area value}_i = (\text{Allowable area} - \text{Actual area}) / 1200 \text{ square feet} \quad \text{(Equation 13-4)}$$

For multiple occupancy buildings:

$$\text{Area value}_i = \frac{\text{Allowable area}_i}{1200 \text{ square feet}} \left[ 1 - \left( \frac{\text{Actual area}_i}{\text{Allowable area}_i} + \dots + \frac{\text{Actual area}_n}{\text{Allowable area}_n} \right) \right]$$

**(Equation 13-5)**

where:

$i$  = Value for an individual separated occupancy on a floor.

$n$  = Number of separated occupancies on a floor.

**1301.6.3 Compartmentation.** Evaluate the compartments created by fire barriers or horizontal assemblies which comply with Sections 1301.6.3.2 and 1301.6.3.3 and which are exclusive of the wall elements considered under Sections 1301.6.4 and 1301.6.5. Conforming compartments shall be figured as the net area and do not include shafts, chases, stairways, walls or columns. Using Table 1301.6.3, determine the appropriate compartmentation value (CV) and enter that value into Table 1301.7 under Safety Parameter 1301.6.3, Compartmentation, for fire safety, means of egress and general safety.

**TABLE 1301.6.3  
COMPARTMENTATION VALUES**

| <b>OCCUPANCY</b> | <b>CATEGORIES<sup>a</sup></b> |          |          |          |          |
|------------------|-------------------------------|----------|----------|----------|----------|
|                  | <b>a</b>                      | <b>b</b> | <b>c</b> | <b>d</b> | <b>e</b> |
| A-1, A-3         | 0                             | 6        | 10       | 14       | 18       |
| A-2              | 0                             | 4        | 10       | 14       | 18       |
| A-4, B, E, S-2   | 0                             | 5        | 10       | 15       | 20       |
| F, M, R, S-1     | 0                             | 4        | 10       | 16       | 22       |
| I-2              | 0                             | 2        | 8        | 10       | 14       |

a. For compartment sizes between categories, the compartmentation value shall be obtained by linear interpolation.

**1301.6.3.1 Categories.** The categories for compartment separations are:

1. Category a—Compartment size of 15,000 square feet (1394 m<sup>2</sup>) or more.
2. Category b—Maximum compartment size of 10,000 square feet (929 m<sup>2</sup>).
3. Category c—Maximum compartment size of 7,500 square feet (697 m<sup>2</sup>).
4. Category d—Maximum compartment size of 5,000 square feet (464 m<sup>2</sup>).
5. Category e—Maximum compartment size of 2,500 square feet (232 m<sup>2</sup>).

**1301.6.3.2 Wall construction.** A wall used to create separate compartments shall be a fire barrier conforming to Section 707 of the *International Building Code* with a fire-resistance rating of not less than 2 hours. Where the building is not divided into more than one compartment, the compartment size shall be taken as the total floor area on all floors. Where there is more than one compartment within a story, each compartmented area on such story shall be provided with a horizontal exit conforming to Section 1026 of the *International Building Code*. The fire door serving as the horizontal exit between compartments shall be so installed, fitted and gasketed that such fire door will provide a substantial barrier to the passage of smoke.

**1301.6.3.3 Floor/ceiling construction.** A floor/ceiling assembly used to create compartments shall conform to Section 711 of the *International Building Code* and shall have a fire-resistance rating of not less than 2 hours.

**1301.6.4 Tenant and dwelling unit separations.** Evaluate the fire-resistance rating of floors and walls separating tenants, including dwelling units, and not evaluated under Sections 1301.6.3 and 1301.6.5. Group I-2 occupancies shall evaluate the rating of the separations between care recipient sleeping rooms.

Under the categories and occupancies in Table 1301.6.4, determine the appropriate value and enter that value in Table 1301.7 under Safety Parameter 1301.6.4, Tenant and Dwelling Unit Separation, for fire safety, means of egress and general safety. The value shall be zero for single tenant buildings and buildings without dwelling units.

**TABLE 1301.6.4**  
**SEPARATION VALUES**

| <u>OCCUPANCY</u>                 | <u>CATEGORIES</u> |           |          |          |          |
|----------------------------------|-------------------|-----------|----------|----------|----------|
|                                  | <u>a</u>          | <u>b</u>  | <u>c</u> | <u>d</u> | <u>e</u> |
| <u>A-1</u>                       | <u>0</u>          | <u>0</u>  | <u>0</u> | <u>0</u> | <u>1</u> |
| <u>A-2</u>                       | <u>-5</u>         | <u>-3</u> | <u>0</u> | <u>1</u> | <u>3</u> |
| <u>R</u>                         | <u>-4</u>         | <u>-2</u> | <u>0</u> | <u>2</u> | <u>4</u> |
| <u>A-3, A-4, B, E, F, M, S-1</u> | <u>-4</u>         | <u>-3</u> | <u>0</u> | <u>2</u> | <u>4</u> |
| <u>I-2</u>                       | <u>0</u>          | <u>1</u>  | <u>2</u> | <u>3</u> | <u>4</u> |
| <u>S-2</u>                       | <u>-5</u>         | <u>-2</u> | <u>0</u> | <u>2</u> | <u>4</u> |

**1301.6.4.1 Categories.** The categories for tenant and dwelling unit separations are:

1. Category a—No fire partitions; incomplete fire partitions; no doors; doors not self-closing or automatic-closing.
2. Category b—Fire partitions or floor assemblies with less than 1-hour fire-resistance ratings or not constructed in accordance with Section 708 or 711 of the *International Building Code*, respectively.
3. Category c—Fire partitions with 1-hour or greater fire-resistance ratings constructed in accordance with Section 708 of the *International Building Code* and floor assemblies with 1-hour but less than 2-hour fire-resistance ratings constructed in accordance with Section 711 of the *International Building Code* or with only one tenant within the floor area.
4. Category d—Fire barriers with 1-hour but less than 2-hour fire-resistance ratings constructed in accordance with Section 707 of the *International Building Code* and floor assemblies with 2-hour or greater fire-resistance ratings constructed in accordance with Section 711 of the *International Building Code*.
5. Category e—Fire barriers and floor assemblies with 2-hour or greater fire-resistance ratings and constructed in accordance with Sections 707 and 711 of the *International Building Code*, respectively.

**1301.6.5 Corridor walls.** Evaluate the fire-resistance rating and degree of completeness of walls which create corridors serving the floor and that are constructed in accordance with Section 1020 of the *International Building Code*. This evaluation shall not include the wall elements considered under Sections 1301.6.3 and 1301.6.4. Under the categories and groups in Table 1301.6.5, determine the appropriate value and enter that value into Table 1301.7 under Safety Parameter 1301.6.5, Corridor Walls, for fire safety, means of egress and general safety.

**TABLE 1301.6.5**  
**CORRIDOR WALL VALUES**

| <u>OCCUPANCY</u> | <u>CATEGORIES</u> |            |                      |                      |
|------------------|-------------------|------------|----------------------|----------------------|
|                  | <u>a</u>          | <u>b</u>   | <u>c<sup>a</sup></u> | <u>d<sup>a</sup></u> |
| <u>A-1</u>       | <u>-10</u>        | <u>-4</u>  | <u>0</u>             | <u>2</u>             |
| <u>A-2</u>       | <u>-30</u>        | <u>-12</u> | <u>0</u>             | <u>2</u>             |

|                          |            |           |          |          |
|--------------------------|------------|-----------|----------|----------|
| <u>A-3, F, M, R, S-1</u> | <u>-7</u>  | <u>-3</u> | <u>0</u> | <u>2</u> |
| <u>A-4, B, E, S-2</u>    | <u>-5</u>  | <u>-2</u> | <u>0</u> | <u>5</u> |
| <u>I-2</u>               | <u>-10</u> | <u>0</u>  | <u>1</u> | <u>2</u> |

a. Corridors not providing at least one-half the exit access travel distance for all occupants on a floor shall use Category b.

**1301.6.5.1 Categories.** The categories for corridor walls are:

1. Category a—No fire partitions; incomplete fire partitions; no doors; or doors not self-closing.
2. Category b—Less than 1-hour fire-resistance rating or not constructed in accordance with Section 708.4 of the *International Building Code*.
3. Category c—1-hour to less than 2-hour fire-resistance rating, with doors conforming to Section 716 of the *International Building Code* or corridors as permitted by Section 1020 of the *International Building Code* to be without a fire-resistance rating.
4. Category d—2-hour or greater fire-resistance rating, with doors conforming to Section 716 of the *International Building Code*.

**1301.6.6 Vertical openings.** Evaluate the fire-resistance rating of interior exit stairways or ramps, hoistways, escalator openings and other shaft enclosures within the building, and openings between two or more floors. Table 1301.6.6(1) contains the appropriate protection values. Multiply that value by the construction-type factor found in Table 1301.6.6(2). Enter the vertical opening value and its sign (positive or negative) in Table 1301.7 under Safety Parameter 1301.6.6, Vertical Openings, for fire safety, means of egress and general safety. If the structure is a one-story building or if all the unenclosed vertical openings within the building conform to the requirements of Section 712 of the *International Building Code*, enter a value of 2. The maximum positive value for this requirement (VO) shall be 2.

**TABLE 1301.6.6(1)  
VERTICAL OPENING PROTECTION VALUE**

| <u>PROTECTION</u>                 | <u>VALUE</u>                               |
|-----------------------------------|--|
| <u>None (unprotected opening)</u> | <u>-2 times number of floors connected</u> |
| <u>Less than 1 hour</u>           | <u>-1 times number of floors connected</u> |
| <u>1 to less than 2 hours</u>     | <u>1</u>                                   |
| <u>2 hours or more</u>            | <u>2</u>                                   |

**TABLE 1301.6.6(2)  
CONSTRUCTION-TYPE FACTOR**

| <u>FACT OR</u> | <u>TYPE OF CONSTRUCTION</u> |            |            |            |             |             |            |            |           |
|----------------|-----------------------------|------------|------------|------------|-------------|-------------|------------|------------|-----------|
|                | <u>IA</u>                   | <u>IB</u>  | <u>IIA</u> | <u>IIB</u> | <u>IIIA</u> | <u>IIIB</u> | <u>IV</u>  | <u>VA</u>  | <u>VB</u> |
|                | <u>1.2</u>                  | <u>1.5</u> | <u>2.2</u> | <u>3.5</u> | <u>2.5</u>  | <u>3.5</u>  | <u>2.3</u> | <u>3.3</u> | <u>7</u>  |

**1301.6.6.1 Vertical opening formula.** The following formula shall be used in computing vertical opening value.



$VO = PV \times CF$  (Equation 13-6)

where:

VO = Vertical opening value. The calculated value shall not be greater than positive 2.0.

PV = Protection value from Table 1301.6.6(1).

CF = Construction-type factor from Table 1301.6.6(2).

**1301.6.7 HVAC systems.** Evaluate the ability of the HVAC system to resist the movement of smoke and fire beyond the point of origin. Under the categories in Section 1301.6.7.1, determine the appropriate value and enter that value into Table 1301.7 under Safety Parameter 1301.6.7, HVAC Systems, for fire safety, means of egress and general safety. *Facilities* in Group I-2 occupancies meeting Category a, b or c shall be considered to fail the evaluation.

**1301.6.7.1 Categories.** The categories for HVAC systems are:

1. Category a—Plenums not in accordance with Section 602 of the *International Mechanical Code*. -10 points.
2. Category b—Air movement in egress elements not in accordance with Section 1020.6 of the *International Building Code*. -5 points.
3. Category c—Both Categories a and b are applicable. -15 points.
4. Category d—Compliance of the HVAC system with Section 1020.6 of the *International Building Code* and Section 602 of the *International Mechanical Code*. 0 points.
5. Category e—Systems serving one story; or a central boiler/chiller system without ductwork connecting two or more stories or where systems have no ductwork. +5 points.

**1301.6.8 Automatic fire detection.** Evaluate the smoke detection capability based on the location and operation of automatic fire detectors in accordance with the *International Mechanical Code* and Section 907 of the *International Building Code*. Under the categories and occupancies in Table 1301.6.8, determine the appropriate value and enter that value into Table 1301.7 under Safety Parameter 1301.6.8, Automatic Fire Detection, for fire safety, means of egress and general safety. *Facilities* in Group I-2 occupancies meeting Category a, b or c shall be considered to fail the evaluation.

**TABLE 1301.6.8  
AUTOMATIC FIRE DETECTION VALUES**

| <b>OCCUPANCY</b>              | <b>CATEGORIES</b> |           |           |          |          |           |
|-------------------------------|-------------------|-----------|-----------|----------|----------|-----------|
|                               | <b>a</b>          | <b>b</b>  | <b>c</b>  | <b>d</b> | <b>e</b> | <b>f</b>  |
| <u>A-1, A-3, F, M, R, S-1</u> | <u>-10</u>        | <u>-5</u> | <u>0</u>  | <u>2</u> | <u>6</u> | <u>NA</u> |
| <u>A-2</u>                    | <u>-25</u>        | <u>-5</u> | <u>0</u>  | <u>5</u> | <u>9</u> | <u>NA</u> |
| <u>A-4, B, E, S-2</u>         | <u>-4</u>         | <u>-2</u> | <u>0</u>  | <u>4</u> | <u>8</u> | <u>NA</u> |
| <u>I-2</u>                    | <u>NP</u>         | <u>NP</u> | <u>NP</u> | <u>4</u> | <u>5</u> | <u>2</u>  |

NA = Not Applicable.

NP = Not Permitted.

**1301.6.8.1 Categories.** The categories for automatic fire detection are:

1. Category a—None.
2. Category b—Existing smoke detectors in HVAC systems and maintained in accordance with the *International Fire Code*.
3. Category c—Smoke detectors in HVAC systems. The detectors are installed in accordance with the requirements for new buildings in the *International Mechanical Code*.

4. Category d—Smoke detectors throughout all floor areas other than individual sleeping units, tenant spaces and dwelling units.
5. Category e—Smoke detectors installed throughout the floor area.
6. Category f—Smoke detectors in corridors only.

**1301.6.9 Fire alarm systems.** Evaluate the capability of the fire alarm system in accordance with Section 907 of the *International Building Code*. Under the categories and occupancies in Table 1301.6.9, determine the appropriate value and enter that value into Table 1301.7 under Safety Parameter 1301.6.9, Fire Alarm System, for fire safety, means of egress and general safety.

**TABLE 1301.6.9  
FIRE ALARM SYSTEM VALUES**

| <u>OCCUPANCY</u>                   | <u>CATEGORIES</u> |                      |           |           |
|------------------------------------|-------------------|----------------------|-----------|-----------|
|                                    | <u>a</u>          | <u>b<sup>a</sup></u> | <u>c</u>  | <u>d</u>  |
| <u>A-1, A-2, A-3, A-4, B, E, R</u> | <u>-10</u>        | <u>-5</u>            | <u>0</u>  | <u>5</u>  |
| <u>F, M, S</u>                     | <u>0</u>          | <u>5</u>             | <u>10</u> | <u>15</u> |
| <u>I-2</u>                         | <u>-4</u>         | <u>1</u>             | <u>2</u>  | <u>5</u>  |

- a. For buildings equipped throughout with an automatic sprinkler system, add 2 points for activation by a sprinkler water-flow device.

**1301.6.9.1 Categories.** The categories for fire alarm systems are:

1. Category a—None.
2. Category b—Fire alarm system with manual fire alarm boxes in accordance with Section 907.4 of the *International Building Code* and alarm notification appliances in accordance with Section 907.5.2 of the *International Building Code*.
3. Category c—Fire alarm system in accordance with Section 907 of the *International Building Code*.
4. Category d—Category c plus a required emergency voice/alarm communications system and a fire command station that conforms to Section 911 of the *International Building Code* and contains the emergency voice/alarm communications system controls, fire department communication system controls, and any other controls specified in Section 911 of the *International Building Code* where those systems are provided.

**1301.6.10 Smoke control.** Evaluate the ability of a natural or mechanical venting, exhaust or pressurization system to control the movement of smoke from a fire. Under the categories and occupancies in Table 1301.6.10, determine the appropriate value and enter that value into Table 1301.7 under Safety Parameter 1301.6.10, Smoke Control, for means of egress and general safety.

**TABLE 1301.6.10  
SMOKE CONTROL VALUES**

| <u>OCCUPANCY</u>     | <u>CATEGORIES</u> |                      |                      |                      |                      |                      |
|----------------------|-------------------|----------------------|----------------------|----------------------|----------------------|----------------------|
|                      | <u>a</u>          | <u>b</u>             | <u>c</u>             | <u>d</u>             | <u>e</u>             | <u>f</u>             |
| <u>A-1, A-2, A-3</u> | <u>0</u>          | <u>1</u>             | <u>2</u>             | <u>3</u>             | <u>6</u>             | <u>6</u>             |
| <u>A-4, E</u>        | <u>0</u>          | <u>0</u>             | <u>0</u>             | <u>1</u>             | <u>3</u>             | <u>5</u>             |
| <u>B, M, R</u>       | <u>0</u>          | <u>2<sup>a</sup></u> | <u>3<sup>a</sup></u> | <u>3<sup>a</sup></u> | <u>3<sup>a</sup></u> | <u>4<sup>a</sup></u> |
| <u>F, S</u>          | <u>0</u>          | <u>2<sup>a</sup></u> | <u>2<sup>a</sup></u> | <u>3<sup>a</sup></u> | <u>3<sup>a</sup></u> | <u>3<sup>a</sup></u> |
| <u>I-2</u>           | <u>-4</u>         | <u>0</u>             | <u>0</u>             | <u>0</u>             | <u>3</u>             | <u>0</u>             |

a. This value shall be 0 if compliance with Category d or e in Section 1301.6.8.1 has not been obtained.

**1301.6.10.1 Categories.** The categories for smoke control are:

1. Category a—None.
2. Category b—The building is equipped throughout with an automatic sprinkler system. Openings are provided in exterior walls at the rate of 20 square feet (1.86 m<sup>2</sup>) per 50 linear feet (15 240 mm) of exterior wall in each story and distributed around the building perimeter at intervals not exceeding 50 feet (15 240 mm). Such openings shall be readily openable from the inside without a key or separate tool and shall be provided with ready access thereto. In lieu of operable openings, clearly and permanently marked tempered glass panels shall be used.
3. Category c—One enclosed exit stairway, with ready access thereto, from each occupied floor of the building. The stairway has operable exterior windows, and the building has openings in accordance with Category b.
4. Category d—One smokeproof enclosure and the building has openings in accordance with Category b.
5. Category e—The building is equipped throughout with an automatic sprinkler system. Each floor area is provided with a mechanical air-handling system designed to accomplish smoke containment. Return and exhaust air shall be moved directly to the outside without recirculation to other floor areas of the building under fire conditions. The system shall exhaust not less than six air changes per hour from the floor area. Supply air by mechanical means to the floor area is not required. Containment of smoke shall be considered as confining smoke to the floor area involved without migration to other floor areas. Any other tested and approved design that will adequately accomplish smoke containment is permitted.
6. Category f—Each stairway shall be one of the following: a smokeproof enclosure in accordance with Section 1023.12 of the *International Building Code*; pressurized in accordance with Section 909.20.5 of the *International Building Code*; or shall have operable exterior windows.

**1301.6.11 Means of egress capacity and number.** Evaluate the means of egress capacity and the number of exits available to the building occupants. In applying this section, the means of egress are required to conform to the following sections of the *International Building Code*: 1003.7, 1004, 1005, 1006, 1007, 1016.2, 1026.1, 1028.3, 1028.5, 1030.2, 1030.3, 1030.4 and 1031. The number of exits credited is the number that is available to each occupant of the area being evaluated. Existing fire escapes shall be accepted as a component in the means of egress when conforming to Section 504.

Under the categories and occupancies in Table 1301.6.11, determine the appropriate value and enter that value into Table 1301.7 under Safety Parameter 1301.6.11, Means of Egress Capacity, for means of egress and general safety.

**TABLE 1301.6.11**  
**MEANS OF EGRESS VALUES**

| <u>OCCUPANCY</u>                  | <u>CATEGORIES</u>    |          |          |          |           |
|-----------------------------------|----------------------|----------|----------|----------|-----------|
|                                   | <u>a<sup>a</sup></u> | <u>b</u> | <u>c</u> | <u>d</u> | <u>e</u>  |
| <u>A-1, A-2, A-3, A-4, E, I-2</u> | <u>-10</u>           | <u>0</u> | <u>2</u> | <u>8</u> | <u>10</u> |
| <u>M</u>                          | <u>-3</u>            | <u>0</u> | <u>1</u> | <u>2</u> | <u>4</u>  |
| <u>B, F, S</u>                    | <u>-1</u>            | <u>0</u> | <u>0</u> | <u>0</u> | <u>0</u>  |
| <u>R</u>                          | <u>-3</u>            | <u>0</u> | <u>0</u> | <u>0</u> | <u>0</u>  |

a. The values indicated are for buildings six stories or less in height. For buildings over six stories above grade plane, add an additional -10 points.

**1301.6.11.1 Categories.** The categories for means-of-egress capacity and number of exits are:

1. Category a—Compliance with the minimum required means-of-egress capacity or number of exits is achieved through the use of a fire escape in accordance with Section 405.
2. Category b—Capacity of the means of egress complies with Section 1005 of the *International Building Code*, and the number of exits complies with the minimum number required by Section 1006 of the *International Building Code*.
3. Category c—Capacity of the means of egress is equal to or exceeds 125 percent of the required means-of-egress capacity, the means of egress complies with the minimum required width dimensions specified in the *International Building Code*, and the number of exits complies with the minimum number required by Section 1006 of the *International Building Code*.
4. Category d—The number of exits provided exceeds the number of exits required by Section 1006 of the *International Building Code*. Exits shall be located a distance apart from each other equal to not less than that specified in Section 1007 of the *International Building Code*.
5. Category e—The area being evaluated meets both Categories c and d.

**1301.6.12 Dead ends.** In spaces required to be served by more than one means of egress, evaluate the length of the exit access travel path in which the building occupants are confined to a single path of travel. Under the categories and occupancies in Table 1301.6.12, determine the appropriate value and enter that value into Table 1301.7 under Safety Parameter 1301.6.12, Dead Ends, for means of egress and general safety.

**TABLE 1301.6.12**  
**DEAD-END VALUES**

| <u>OCCUPANCY</u>                    | <u>CATEGORIES<sup>a</sup></u> |          |          |           |
|-------------------------------------|-------------------------------|----------|----------|-----------|
|                                     | <u>a</u>                      | <u>b</u> | <u>c</u> | <u>d</u>  |
| <u>A-1, A-3, A-4, B, F, M, R, S</u> | <u>-2</u>                     | <u>0</u> | <u>2</u> | <u>-4</u> |
| <u>A-2, E</u>                       | <u>-2</u>                     | <u>0</u> | <u>2</u> | <u>-4</u> |
| <u>I-2</u>                          | <u>-2</u>                     | <u>0</u> | <u>2</u> | <u>-6</u> |

a. For dead-end distances between categories, the dead-end value shall be obtained by linear interpolation.

**1301.6.12.1 Categories.** The categories for dead ends are:

1. Category a—Dead end of 35 feet (10 670 mm) in nonsprinklered buildings or 70 feet (21 340 mm) in sprinklered buildings.
2. Category b—Dead end of 20 feet (6096 mm); or 50 feet (15 240 mm) in Group B in accordance with Section 1020.5, Exception 2, of the *International Building Code*.
3. Category c—No dead ends; or ratio of length to width (l/w) is less than 2.5:1.
4. Category d—Dead ends exceeding Category a.

**1301.6.13 Maximum exit access travel distance to an exit.** Evaluate the length of exit access travel to an *approved* exit. Determine the appropriate points in accordance with the following equation and enter that value into Table 1301.7 under Safety Parameter 1301.6.13, Maximum Exit Access Travel Distance for means of egress and general safety. The maximum allowable exit access travel distance shall be determined in accordance with Section 1017.1 of the *International Building Code*.

$$\text{Points} = 20 \times \frac{\text{Maximum allowable travel distance} - \text{Maximum actual travel distance}}{\text{Maximum allowable travel distance}}$$

**(Equation 13-7)**

**1301.6.14 Elevator control.** Evaluate the passenger elevator equipment and controls that are available to the fire department to reach all occupied floors. Emergency recall and in-car operation of elevators shall be provided in accordance with the *International Fire Code*. Under the categories and occupancies in Table 1301.6.14, determine the appropriate value and enter that value into Table 1301.7 under Safety Parameter 1301.6.14, Elevator Control, for fire safety, means of egress and general safety. The values shall be zero for a single-story building.

**TABLE 1301.6.14  
ELEVATOR CONTROL VALUES**

| <b>ELEVATOR TRAVEL</b>   | <b>CATEGORIES</b> |          |          |          |
|--|-------------------|----------|----------|----------|
|  | <b>a</b>          | <b>b</b> | <b>c</b> | <b>d</b> |
| <u>Less than 25 feet of travel above or below the primary level of elevator access for emergency fire-fighting or rescue personnel</u> | -2                | 0        | 0        | +2       |
| <u>Travel of 25 feet or more above or below the primary level of elevator access for emergency fire-fighting or rescue personnel</u>   | -4                | NP       | 0        | +4       |

For SI: 1 foot = 304.8 mm.

NP = Not Permitted.

**1301.6.14.1 Categories.** The categories for elevator controls are:

1. Category a—No elevator.
2. Category b—Any elevator without Phase I emergency recall operation and Phase II emergency in-car operation.
3. Category c—All elevators with Phase I emergency recall operation and Phase II emergency in-car operation as required by the *International Fire Code*.
4. Category d—All meet Category c; or Category b where permitted to be without Phase I emergency recall operation and Phase II emergency in-car operation; and at least one elevator that complies with new construction requirements serves all occupied floors.

**1301.6.15 Means of egress emergency lighting.** Evaluate the presence of and reliability of means of egress emergency lighting. Under the categories and occupancies in Table 1301.6.15, determine the appropriate value and enter that value into Table 1301.7 under Safety Parameter 1301.6.15, Means of Egress Emergency Lighting, for means of egress and general safety.

**TABLE 1301.6.15  
MEANS OF EGRESS EMERGENCY LIGHTING VALUES**

| <b>CATEGORIES</b> |
|-------------------|
|-------------------|

| <b><u>NUMBER OF EXITS<br/>REQUIRED BY<br/>SECTION 1006 OF THE<br/>INTERNATIONAL BUILDING<br/>CODE</u></b> | <b><u>a</u></b> | <b><u>b</u></b> | <b><u>c</u></b> |
|---|-----------------|-----------------|-----------------|
| <u>Two or more exits</u>  | <u>NP</u>       | <u>0</u>        | <u>4</u>        |
| <u>Minimum of one exit</u>  | <u>0</u>        | <u>1</u>        | <u>1</u>        |

NP = Not Permitted.

**1301.6.15.1 Categories.** The categories for means of egress emergency lighting are:

1. Category a—Means-of-egress lighting and exit signs not provided with emergency power in accordance with Section 2702 of the *International Building Code*.
2. Category b—Means of egress lighting and exit signs provided with emergency power in accordance with Section 2702 of the *International Building Code*.
3. Category c—Emergency power provided to means of egress lighting and exit signs, which provides protection in the event of power failure to the site or building.

**1301.6.16 Mixed occupancies.** Where a building has two or more occupancies that are not in the same occupancy classification, the separation between the mixed occupancies shall be evaluated in accordance with this section. Where there is no separation between the mixed occupancies or the separation between mixed occupancies does not qualify for any of the categories indicated in Section 1301.6.16.1, the building shall be evaluated as indicated in Section 1301.6, and the value for mixed occupancies shall be zero. Under the categories and occupancies in Table 1301.6.16, determine the appropriate value and enter that value into Table 1301.7 under Safety Parameter 1301.6.16, Mixed Occupancies, for fire safety and general safety. For buildings without mixed occupancies, the value shall be zero. *Facilities* in Group I-2 occupancies meeting Category a shall be considered to fail the evaluation.

**TABLE 1301.6.16**  
**MIXED OCCUPANCY VALUES<sup>a</sup>**

| <u>OCCUPANCY</u>               | <u>CATEGORIES</u> |          |           |
|--------------------------------|-------------------|----------|-----------|
|                                | <u>a</u>          | <u>b</u> | <u>c</u>  |
| <u>A-1, A-2, R</u>             | <u>-10</u>        | <u>0</u> | <u>10</u> |
| <u>A-3, A-4, B, E, F, M, S</u> | <u>-5</u>         | <u>0</u> | <u>5</u>  |
| <u>I-2</u>                     | <u>NP</u>         | <u>0</u> | <u>5</u>  |

NP = Not Permitted.

a. For fire-resistance ratings between categories, the value shall be obtained by linear interpolation.

**1301.6.16.1 Categories.** The categories for mixed occupancies are:

1. Category a—Occupancies separated by minimum 1-hour fire barriers or minimum 1-hour horizontal assemblies, or both.
2. Category b—Separations between occupancies in accordance with Section 508.4 of the *International Building Code*.
3. Category c—Separations between occupancies having a fire-resistance rating of not less than twice that required by Section 508.4 of the *International Building Code*.

**1301.6.17 Automatic sprinklers.** Evaluate the ability to suppress or control a fire based on the installation of an automatic sprinkler system in accordance with Section 903.3.1 of the *International Building Code*. “Required sprinklers” shall be based on the requirements of the *International Building Code*. Under the categories and occupancies in Table 1301.6.17, determine the appropriate value and enter that value into Table 1301.7 under Safety Parameter 1301.6.17, Automatic Sprinklers, for fire safety, means of egress divided by 2, and general safety. High-rise buildings defined in Chapter 2 of the *International Building Code* that undergo a *change of occupancy* to Group R shall be equipped throughout with an automatic sprinkler system in accordance with Section 403 of the *International Building Code* and Chapter 9 of the *International Building Code*. Facilities in Group I-2 occupancies meeting Category a, b, c or f shall be considered to fail the evaluation.

**TABLE 1301.6.17  
SPRINKLER SYSTEM VALUES**

| <u>OCCUPANCY</u>              | <u>CATEGORIES</u>    |                      |           |          |           |           |
|-------------------------------|----------------------|----------------------|-----------|----------|-----------|-----------|
|                               | <u>a<sup>a</sup></u> | <u>b<sup>a</sup></u> | <u>c</u>  | <u>d</u> | <u>e</u>  | <u>f</u>  |
| <u>A-1, A-3, F, M, R, S-1</u> | <u>-6</u>            | <u>-3</u>            | <u>0</u>  | <u>2</u> | <u>4</u>  | <u>6</u>  |
| <u>A-2</u>                    | <u>-4</u>            | <u>-2</u>            | <u>0</u>  | <u>1</u> | <u>2</u>  | <u>4</u>  |
| <u>A-4, B, E, S-2</u>         | <u>-12</u>           | <u>-6</u>            | <u>0</u>  | <u>3</u> | <u>6</u>  | <u>12</u> |
| <u>I-2</u>                    | <u>NP</u>            | <u>NP</u>            | <u>NP</u> | <u>8</u> | <u>10</u> | <u>NP</u> |

NP = Not Permitted.

a. These options cannot be taken if Category a in Section 1301.6.18 is used.

**1301.6.17.1 Categories.** The categories for automatic sprinkler system protection are:

1. Category a—An approved automatic sprinkler system is required throughout; an approved automatic sprinkler system is not provided.
2. Category b—An approved automatic sprinkler system is required in a portion of a building; an approved automatic sprinkler system is not provided; the sprinkler system design is not adequate for the hazard protected in accordance with Chapter 9 of the International Building Code.
3. Category c—An approved automatic sprinkler system is not required; none are provided.
4. Category d—An approved automatic sprinkler system is required in a portion of a building; an approved automatic sprinkler system is provided in a portion of a building in accordance with Chapter 9 of the International Building Code.
5. Category e—An approved automatic sprinkler system is required throughout; an approved automatic sprinkler system is provided throughout in accordance with Chapter 9 of the International Building Code.
6. Category f—An approved automatic sprinkler system is not required throughout; an approved automatic sprinkler system is provided throughout in accordance with Chapter 9 of the International Building Code.

**1301.6.18 Standpipes.** Evaluate the ability to initiate attack on a fire by making a supply of water readily available through the installation of standpipes in accordance with Section 905 of the International Building Code. “Required Standpipes” shall be based on the requirements of the International Building Code. Under the categories and occupancies in Table 1301.6.18, determine the appropriate value and enter that value into Table 1301.7 under Safety Parameter 1301.6.18, Standpipes, for fire safety, means of egress and general safety.



**TABLE 1301.6.18  
STANDPIPE SYSTEM VALUES**

| <u>OCCUPANCY</u>              | <u>CATEGORIES</u>    |          |          |           |
|-------------------------------|----------------------|----------|----------|-----------|
|                               | <u>a<sup>a</sup></u> | <u>b</u> | <u>c</u> | <u>d</u>  |
| <u>A-1, A-3, F, M, R, S-1</u> | <u>-6</u>            | <u>0</u> | <u>4</u> | <u>6</u>  |
| <u>A-2</u>                    | <u>-4</u>            | <u>0</u> | <u>2</u> | <u>4</u>  |
| <u>A-4, B, E, S-2</u>         | <u>-12</u>           | <u>0</u> | <u>6</u> | <u>12</u> |
| <u>I-2</u>                    | <u>-2</u>            | <u>0</u> | <u>1</u> | <u>2</u>  |

a. This option cannot be taken if Category a or Category b in Section 1301.6.17 is used.

**1301.6.18.1 Standpipe categories.** The categories for standpipe systems are:

1. Category a—Standpipes are required; standpipe is not provided or the standpipe system design is not in compliance with Section 905.3 of the *International Building Code*.
2. Category b—Standpipes are not required; none are provided.
3. Category c—Standpipes are required; standpipes are provided in accordance with Section 905 of the *International Building Code*.
4. Category d—Standpipes are not required; standpipes are provided in accordance with Section 905 of the *International Building Code*.

**1301.6.19 Incidental uses.** Evaluate the protection of incidental uses in accordance with Section 509.4.2 of the *International Building Code*. Do not include those where this code requires automatic sprinkler systems throughout the building including covered and open mall buildings, high-rise buildings, public garages and unlimited area buildings. Assign the lowest score from Table 1301.6.19 for the building or floor area being evaluated and enter that value into Table 1301.7 under Safety Parameter 1301.6.19, Incidental Uses, for fire safety, means of egress and general safety. If there are no specific occupancy areas in the building or floor area being evaluated, the value shall be zero.

**TABLE 1301.6.19  
INCIDENTAL USE AREA VALUES**

| <b>PROTECTION<br/>REQUIRED BY TABLE<br/>509.1<br/>OF THE<br/>INTERNATIONAL<br/>BUILDING CODE</b> | <b>PROTECTION PROVIDED</b> |               |           |                        |                              |                |                           |
|--|----------------------------|---------------|-----------|------------------------|------------------------------|----------------|---------------------------|
|  | <b>None</b>                | <b>1 hour</b> | <b>AS</b> | <b>AS with<br/>CRS</b> | <b>1 hour<br/>and<br/>AS</b> | <b>2 hours</b> | <b>2 hours<br/>and AS</b> |
| <u>2 hours and AS</u>  | <u>-4</u>                  | <u>-3</u>     | <u>-2</u> | <u>-2</u>              | <u>-1</u>                    | <u>-2</u>      | <u>0</u>                  |
| <u>2 hours, or 1 hour and AS</u>   | <u>-3</u>                  | <u>-2</u>     | <u>-1</u> | <u>-1</u>              | <u>0</u>                     | <u>0</u>       | <u>0</u>                  |
| <u>1 hour and AS</u>   | <u>-3</u>                  | <u>-2</u>     | <u>-1</u> | <u>-1</u>              | <u>0</u>                     | <u>-1</u>      | <u>0</u>                  |
| <u>1 hour</u>  | <u>-1</u>                  | <u>0</u>      | <u>-1</u> | <u>-1</u>              | <u>0</u>                     | <u>0</u>       | <u>0</u>                  |
| <u>1 hour, or AS with CRS</u>  | <u>-1</u>                  | <u>0</u>      | <u>-1</u> | <u>-1</u>              | <u>0</u>                     | <u>0</u>       | <u>0</u>                  |
| <u>AS with CRS</u>   | <u>-1</u>                  | <u>-1</u>     | <u>-1</u> | <u>-1</u>              | <u>0</u>                     | <u>-1</u>      | <u>0</u>                  |
| <u>1 hour or AS</u>  | <u>-1</u>                  | <u>0</u>      | <u>0</u>  | <u>0</u>               | <u>0</u>                     | <u>0</u>       | <u>0</u>                  |

AS = Automatic Sprinkler System.

CRS = Construction capable of resisting the passage of smoke (see Section 509.4.2 of the *International Building Code*).

**1301.6.20 Smoke compartmentation.** Evaluate the smoke compartments for compliance with Section 407.5 of the *International Building Code*. Under the categories and occupancies in Table 1301.6.20, determine the appropriate smoke compartmentation value (SCV) and enter that value into Table 1301.7 under Safety Parameter 1301.6.20, Smoke Compartmentation, for fire safety, means of egress and general safety. Facilities in Group I-2 occupancies meeting Category b or c shall be considered to fail the evaluation.

**TABLE 1301.6.20**  
**SMOKE COMPARTMENTATION VALUES**

| <u>OCCUPANCY</u>              | <u>CATEGORIES<sup>a</sup></u> |            |           |
|-------------------------------|-------------------------------|------------|-----------|
|                               | <u>a</u>                      | <u>b</u>   | <u>c</u>  |
| <u>A, B, E, F, M, R and S</u> | <u>0</u>                      | <u>0</u>   | <u>0</u>  |
| <u>I-2</u>                    | <u>0</u>                      | <u>-10</u> | <u>NP</u> |

NP = Not Permitted.

a. For areas between categories, the smoke compartmentation value shall be obtained by linear interpolation.

**1301.6.20.1 Categories.** Categories for smoke compartment size are:

1. Category a—Smoke compartment complies with Section 407.5 of the *International Building Code*.
2. Category b—Smoke compartment are provided but do not comply with Section 407.5 of the *International Building Code*.
3. Category c—Smoke compartments are not provided.

**1301.6.21 Care recipient ability, concentration, smoke compartment location and ratio to attendant.** In I-2 occupancies, the ability of care recipients, their concentration and ratio to attendants shall be evaluated and applied in accordance with this section. Evaluate each smoke compartment using the categories in Sections 1301.6.21.1, 1301.6.21.2 and 1301.6.21.3 and enter the value in Table 1301.7. To determine the safety factor, multiply the three values together; if the product is less than 6, compliance has failed.

**1301.6.21.1 Care recipient ability for self-preservation.** Evaluate the ability of the care recipients for self-preservation in each smoke compartment in an emergency. Under the categories and occupancies in Table 1301.6.21.1, determine the appropriate value and enter that value in Table 1301.7 under Safety Parameter 1301.6.21.1, Care Recipient Ability for Self-preservation, for means of egress and general safety.

**TABLE 1301.6.21.1**  
**CARE RECIPIENT ABILITY VALUES**

| <u>OCCUPANCY</u> | <u>CATEGORIES</u> |          |          |
|------------------|-------------------|----------|----------|
|                  | <u>a</u>          | <u>b</u> | <u>c</u> |
| <u>I-2</u>       | <u>3</u>          | <u>2</u> | <u>1</u> |

**1301.6.21.1.1 Categories.** The categories for care recipient ability for self-preservation are:

1. Category a—(mobile) Care recipients are capable of self-preservation without assistance.
2. Category b—(not mobile) Care recipients rely on assistance for evacuation or relocation.
3. Category c—(not movable) Care recipients cannot be evacuated or relocated.

**1301.6.21.2 Care recipient concentration.** Evaluate the concentration of care recipients in each smoke compartment under Section 1301.6.21.2. Under the categories and occupancies in Table 1301.6.21.2 determine the appropriate value and enter that value in Table 1301.7 under Safety Parameter 1301.6.21.2, Care Recipient Concentration, for means of egress and general safety.

**TABLE 1301.6.21.2**  
**CARE RECIPIENT CONCENTRATION VALUES**

| <u>OCCUPANCY</u> | <u>CATEGORIES</u> |          |          |
|------------------|-------------------|----------|----------|
|                  | <u>a</u>          | <u>b</u> | <u>c</u> |
| <u>I-2</u>       | <u>3</u>          | <u>2</u> | <u>1</u> |

**1301.6.21.2.1 Categories:** The categories for care recipient concentration are:

1. Category a—smoke compartment has 1 to 10 care recipients.
2. Category b—smoke compartment has more than 10 to 40 care recipients.
3. Category c—smoke compartment has more than 40 care recipients.

**1301.6.21.3 Attendant-to-care recipients ratio.** Evaluate the attendant-to-care recipients ratio for each compartment under Section 1301.6.21.3. Under the categories and occupancies in Table 1301.6.21.3 determine the appropriate value and enter that value in Table 1301.7 under Safety Parameter 1301.6.21.3, Attendant-to-Care Recipients Ratio, for means of egress and general safety.

**TABLE 1301.6.21.3  
ATTENDANT-TO-CARE RECIPIENTS RATIO VALUES**

| <b><u>OCCUPANCY</u></b> | <b><u>CATEGORIES</u></b> |                 |                 |
|-------------------------|--------------------------|-----------------|-----------------|
|                         | <b><u>a</u></b>          | <b><u>b</u></b> | <b><u>c</u></b> |
| <b><u>I-2</u></b>       | <b><u>3</u></b>          | <b><u>2</u></b> | <b><u>1</u></b> |

**1301.6.21.3.1 Categories.** The categories for attendant-to-care recipient concentrations are:

1. Category a—attendant-to-care recipients concentration is 1:5 or no care recipients.
2. Category b—attendant-to-care recipients concentration is 1:6 to 1:10.
3. Category c—attendant-to-care recipients concentration is greater than 1:10.

**1301.7 Building score.** After determining the appropriate data from Section 1301.6, enter those data in Table 1301.7 and total the building score.

**1301.8 Safety scores.** The values in Table 1301.8 are the required mandatory safety scores for the evaluation process listed in Section 1301.6.

**TABLE 1301.8**  
**MANDATORY SAFETY SCORES<sup>a</sup>**

| <u>OCCUPANCY</u> | <u>FIRE SAFETY(MFS)</u> | <u>MEANS OF EGRESS (MME)</u> | <u>GENERAL SAFETY (MGS)</u> |
|------------------|-------------------------|------------------------------|-----------------------------|
| <u>A-1</u>       | <u>20</u>               | <u>31</u>                    | <u>31</u>                   |
| <u>A-2</u>       | <u>21</u>               | <u>32</u>                    | <u>32</u>                   |
| <u>A-3</u>       | <u>22</u>               | <u>33</u>                    | <u>33</u>                   |
| <u>A-4, E</u>    | <u>29</u>               | <u>40</u>                    | <u>40</u>                   |
| <u>B</u>         | <u>30</u>               | <u>40</u>                    | <u>40</u>                   |
| <u>F</u>         | <u>24</u>               | <u>34</u>                    | <u>34</u>                   |
| <u>I-2</u>       | <u>19</u>               | <u>34</u>                    | <u>34</u>                   |
| <u>M</u>         | <u>23</u>               | <u>40</u>                    | <u>40</u>                   |
| <u>R</u>         | <u>21</u>               | <u>38</u>                    | <u>38</u>                   |
| <u>S-1</u>       | <u>19</u>               | <u>29</u>                    | <u>29</u>                   |
| <u>S-2</u>       | <u>29</u>               | <u>39</u>                    | <u>39</u>                   |

a. MFS = Mandatory Fire Safety.  
MME = Mandatory Means of Egress.  
MGS = Mandatory General Safety.

**1301.9 Evaluation of building safety.** The mandatory safety score in Table 1301.8 shall be subtracted from the building score in Table 1301.7 for each category in accordance with the evaluation formulas in Table 1301.9. Where the final score for any category equals zero or more, the building is in compliance with the requirements of this section for that category. Where the final score for any category is less than zero, the building is not in compliance with the requirements of this section.

**1301.9.1 Mixed occupancies.** For mixed occupancies, the following provisions shall apply:

1. Where the separation between mixed occupancies does not qualify for any category indicated in Section 1301.6.16, the mandatory safety scores for the occupancy with the lowest general safety score in Table 1301.8 shall be utilized (see Section 1301.6).
2. Where the separation between mixed occupancies qualifies for any category indicated in Section 1301.6.16, the mandatory safety scores for each occupancy shall be placed against the evaluation scores for the appropriate occupancy. An evaluation is not required for areas of the building with separated occupancies in accordance with Table 508.4 of the *International Building Code* in which there are no *alterations* or *change of occupancy*.

13-1  
13-2  
13-3  
13-4  
13-5  
13-6  
13-7  
13-8  
13-9  
13-10  
13-11  
13-12



**TABLE 1301.7  
SUMMARY SHEET—BUILDING CODE**

|  |                                |  |                                   |
|--|--------------------------------|--|-----------------------------------|
| Existing occupancy: _____  |                                | Proposed occupancy: _____                            |                                   |
| Year building was constructed: _____                                     |                                | Number of stories: _____                             | Height in feet: _____             |
| Type of construction: _____  |                                | Area per floor: _____                                |                                   |
| Percentage of open perimeter increase: _____ %                           |                                |  |                                   |
| Completely suppressed:   | Yes _____ No _____             | Corridor wall rating: _____                          |                                   |
|  |                                | Type: _____  |                                   |
| Compartmentation:  | Yes _____ No _____             | Required door closers:                               | Yes _____<br>No _____             |
| Fire-resistance rating of vertical opening enclosures: _____             |                                |  |                                   |
| Type of HVAC system: _____, serving number of floors: _____              |                                |  |                                   |
| Automatic fire detection:  | Yes _____<br>No _____          | Type and location: _____                             |                                   |
| Fire alarm system:   | Yes _____<br>No _____          | Type: _____  |                                   |
| Smoke control:   | Yes _____<br>No _____          | Type: _____  |                                   |
| Adequate exit routes:  | Yes _____<br>No _____          | Dead ends:   | Yes _____ No _____                |
| Maximum exit access travel distance: _____                               |                                | Elevator controls:                                   | Yes _____ No _____                |
| Means of egress emergency lighting:                                      | Yes _____ No _____             | Mixed occupancies:                                   | Yes _____ No _____                |
| Standpipes:  | Yes _____<br>No _____          | Care recipients ability for self-preservation: _____ |                                   |
| Incidental use:  | Yes _____<br>No _____          | Care recipients concentration: _____                 |                                   |
| Smoke compartmentation less than 22,500 sq. feet (2092 m <sup>2</sup> ): | Yes _____<br>No _____          | Attendant-to-care recipients ratio: _____            |                                   |
| <b><u>SAFETY PARAMETERS</u></b>  | <b><u>FIRE SAFETY (FS)</u></b> | <b><u>MEANS OF EGRESS (ME)</u></b>                   | <b><u>GENERAL SAFETY (GS)</u></b> |
| 1301.6.1 Building height   |                                |  |                                   |
| 1301.6.2 Building area   |                                |  |                                   |
| 1301.6.3 Compartmentation  |                                |  |                                   |
| 1301.6.4 Tenant and dwelling unit separations                            |                                |  |                                   |
| 1301.6.5 Corridor walls  |                                |  |                                   |
| 1301.6.6 Vertical openings   |                                |  |                                   |
| 1301.6.7 HVAC systems  |                                |  |                                   |

|  |            |              |  |
|--|------------|--------------|--|
| <u>1301.6.8 Automatic fire detection</u>                                     |            |              |  |
| <u>1301.6.9 Fire alarm system</u>  |            |              |  |
| <u>1301.6.10 Smoke control</u>   | <u>***</u> |              |  |
| <u>1301.6.11 Means of egress</u>   | <u>***</u> |              |  |
| <u>1301.6.12 Dead ends</u>   | <u>***</u> |              |  |
| <u>1301.6.13 Maximum exit access travel distance</u>                         | <u>***</u> |              |  |
| <u>1301.6.14 Elevator control</u>  |            |              |  |
| <u>1301.6.15 Means of egress emergency lighting</u>                          | <u>***</u> |              |  |
| <u>1301.6.16 Mixed occupancies</u>   |            | <u>***</u>   |  |
| <u>1301.6.17 Automatic sprinklers</u>  |            | <u>÷ 2 =</u> |  |
| <u>1301.6.18 Standpipes</u>  |            |              |  |
| <u>1301.6.19 Incidental use</u>  |            |              |  |
| <u>1301.6.20 Smoke compartmentation</u>                                      |            |              |  |
| <u>1301.6.21.1 Care recipients ability for self-preservation<sup>a</sup></u> | <u>***</u> |              |  |
| <u>1301.6.21.2 Care recipients concentration<sup>a</sup></u>                 | <u>***</u> |              |  |
| <u>1301.6.21.3 Attendant-to-care recipients ratio<sup>a</sup></u>            | <u>***</u> |              |  |
| <b><u>Building score–total value</u></b>                                     |            |              |  |

\*\*\*No applicable value to be inserted.

a. Only applicable to Group I-2 occupancies.

**TABLE 1301.9  
EVALUATION FORMULAS<sup>a</sup>**

| <b>FORMULA</b>      | <b>TABLE 1301.7</b> | <b>TABLE 1301.8</b> |          | <b>SCORE</b> | <b>PASS</b>  | <b>FAIL</b>  |
|---------------------|---------------------|---------------------|----------|--------------|--------------|--------------|
| <u>FS – MFS ≥ 0</u> | <u>_____ (FS) –</u> | <u>_____ (MFS)</u>  | <u>≡</u> | <u>_____</u> | <u>_____</u> | <u>_____</u> |
| <u>ME – MME ≥ 0</u> | <u>_____ (ME) –</u> | <u>_____ (MME)</u>  | <u>≡</u> | <u>_____</u> | <u>_____</u> | <u>_____</u> |
| <u>GS – MGS ≥ 0</u> | <u>_____ (GS) –</u> | <u>_____ (MGS)</u>  | <u>≡</u> | <u>_____</u> | <u>_____</u> | <u>_____</u> |

a. FS = Fire Safety.

ME = Means of Egress.

GS = General Safety.

MFS = Mandatory Fire Safety.

MME = Mandatory Means of Egress.

MGS = Mandatory General Safety.

## CHAPTER 14 PERFORMANCE COMPLIANCE METHODS



## SECTION 1401 GENERAL

### **1401.1 Scope.**

The provisions of this chapter shall apply to the ~~alteration, repair, addition and change of occupancy~~ of existing structures, including historic and moved structures, as referenced in Section 301.1.3. The provisions of this chapter are intended to maintain or increase the current degree of public safety, health and general welfare in ~~existing buildings while permitting repair, alteration, addition and change of occupancy~~ without requiring full compliance with Chapters 5 through 13, except where compliance with other provisions of this code is specifically required in this chapter.

#### **1401.1.1 Compliance with other methods.**

~~Alterations, repairs, additions and changes of occupancy~~ to existing structures shall comply with the provisions of this chapter or with one of the methods provided in Section 301.1.

### **1401.2 Applicability.**

Structures existing prior to ~~[DATE TO BE INSERTED BY THE JURISDICTION. Note: it is recommended that this date coincide with the effective date of building codes within the jurisdiction]~~, in which there is work involving ~~additions, alterations or changes of occupancy~~ shall be made to conform to the requirements of this chapter or the provisions of Chapters 5 through 13. The provisions of Sections 1401.2.1 through 1401.2.5 shall apply to existing occupancies that will continue to be, or are proposed to be, in Groups A, B, E, F, I-2, M, R and S. These provisions shall not apply to buildings with occupancies in Group H or I-1, I-3 or I-4.

#### **1401.2.1 Change in occupancy.**

~~Where an existing building is changed to a new occupancy classification and this section is applicable, the provisions of this section for the new occupancy shall be used to determine compliance with this code.~~

#### **1401.2.2 Partial change in occupancy.**

~~Where a portion of the building is changed to a new occupancy classification and that portion is separated from the remainder of the building with fire barrier or horizontal assemblies having a fire resistance rating as required by Table 508.4 of the *International Building Code* or Section R302 of the *International Residential Code* for the separate occupancies, or with approved compliance alternatives, the portion changed shall be made to conform to the provisions of this section.~~

~~Where a portion of the building is changed to a new occupancy classification and that portion is not separated from the remainder of the building with fire barriers or horizontal assemblies having a fire resistance rating as required by Table 508.4 of the *International Building Code* or Section R302 of the *International Residential Code* for the separate occupancies, or with approved compliance alternatives, the provisions of this section which apply to each occupancy shall apply to the entire building. Where there are conflicting provisions, those requirements which secure the greater public safety shall apply to the entire building or structure.~~

#### **1401.2.3 Additions.**

~~Additions to existing buildings shall comply with the requirements of the *International Building Code*, *International Residential Code*, and this code for new construction. The combined height and area of the existing building and the new addition shall not exceed the height and area allowed by Chapter 5 of the *International Building Code*. Where a fire wall that complies with Section 706 of the *International Building*~~

~~Code is provided between the *addition* and the *existing building*, the *addition* shall be considered a separate building.~~

**~~1401.2.4 Alterations and repairs.~~**

~~An *existing building* or portion thereof that does not comply with the requirements of this code for new construction shall not be altered or repaired in such a manner that results in the building being less safe or sanitary than such building is currently. If, in the *alteration* or *repair*, the current level of safety or sanitation is to be reduced, the portion altered or repaired shall conform to the requirements of Chapters 2 through 12 and Chapters 14 through 33 of the *International Building Code*.~~

**~~1401.2.5 Accessibility requirements.~~**

~~Accessibility shall be provided in accordance with Section 410 or 806.~~

**~~1401.2.6 Occupant load increase.~~**

~~Where the existing occupant load is increased by more than 20 percent or in Group A occupancies where the occupant load is greater than 300, compliance with Chapter 14 is not permitted. Compliance with other methods in this code shall be permitted.~~

**~~1401.3 Acceptance.~~**

~~For *repairs*, *alterations*, *additions*, and *changes of occupancy* to *existing buildings* that are evaluated in accordance with this section, compliance with this section shall be accepted by the *code official*.~~

**~~1401.3.1 Hazards.~~**

~~Where the *code official* determines that an unsafe condition exists as provided for in Section 115, such unsafe condition shall be abated in accordance with Section 115.~~

**~~1401.3.2 Compliance with other codes.~~**

~~Buildings that are evaluated in accordance with this section shall comply with the *International Fire Code*.~~

**~~1401.3.3 Compliance with flood hazard provisions.~~**

~~In *flood hazard areas*, buildings that are evaluated in accordance with this section shall comply with Section 1612 of the *International Building Code*, or Section R322 of the *International Residential Code*, as applicable if the work covered by this section constitutes *substantial improvement*.~~

**~~1401.4 Investigation and evaluation.~~**

~~For proposed work covered by this chapter, the building owner shall cause the *existing building* to be investigated and evaluated in accordance with the provisions of Sections 1401.4 through 1401.9.~~

**~~[BS] 1401.4.1 Structural analysis.~~**

~~The owner shall have a structural analysis of the *existing building* made to determine adequacy of structural systems for the proposed *alteration*, *addition* or *change of occupancy*. The analysis shall demonstrate that the building with the work completed is capable of resisting the loads specified in Chapter 16 of the *International Building Code*.~~

#### **1401.4.2 Submittal.**

The results of the investigation and evaluation as required in Section 1401.4, along with proposed compliance alternatives, shall be submitted to the *code official*.

#### **1401.4.3 Determination of compliance.**

The *code official* shall determine whether the *existing building*, with the proposed *addition, alteration, or change of occupancy*, complies with the provisions of this section in accordance with the evaluation process in Sections 1401.5 through 1401.9.

#### **1401.5 Evaluation.**

The evaluation shall be comprised of three categories: fire safety, means of egress, and general safety, as defined in Sections 1401.5.1 through 1401.5.3.

##### **1401.5.1 Fire safety.**

Included within the fire safety category are the structural fire resistance, automatic fire detection, fire alarm, automatic sprinkler system and fire suppression system features of the *facility*.

##### **1401.5.2 Means of egress.**

Included within the means of egress category are the configuration, characteristics, and support features for means of egress in the facility.

##### **1401.5.3 General safety.**

Included within the general safety category are the fire safety parameters and the means of egress parameters.

#### **1401.6 Evaluation process.**

The evaluation process specified herein shall be followed in its entirety to evaluate *existing buildings* in Groups A, B, E, F, M, R, S and U. For existing buildings in Group I-2, the evaluation process specified herein shall be followed and applied to each and every individual smoke compartment. Table 1401.7 shall be utilized for tabulating the results of the evaluation. References to other sections of this code indicate that compliance with those sections is required in order to gain credit in the evaluation herein outlined. In applying this section to a building with mixed occupancies, where the separation between the mixed occupancies does not qualify for any category indicated in Section 1401.6.16, the score for each occupancy shall be determined, and the lower score determined for each section of the evaluation process shall apply to the entire building, or to each smoke compartment for Group I-2 occupancies.

Where the separation between the mixed occupancies qualifies for any category indicated in Section 1401.6.16, the score for each occupancy shall apply to each portion, or smoke compartment of the building based on the occupancy of the space.

##### **1401.6.1 Building height and number of stories.**

The value for building height and number of stories shall be the lesser value determined by the formula in Section 1401.6.1.1. Section 504 of the *International Building Code* shall be used to determine the allowable height and number of stories of the building. Subtract the actual building height from the allowable height and divide by  $12 \frac{1}{2}$  feet (3810 mm). Enter the height value and its sign (positive or negative) in Table 1401.7 under Safety Parameter 1401.6.1, Building Height, for fire safety, means of egress, and general safety. The maximum score for a building shall be 10.

#### 1401.6.1.1 Height formula.

The following formulas shall be used in computing the building height value.

$$\text{Height value, feet} = \frac{(AH) - (EBH)}{125} \times CF \quad \text{(Equation 14-1)}$$

$$\text{Height value, stories} = (AS - EBS) \times CF \quad \text{(Equation 14-2)}$$

where:

*AH* = Allowable height in feet (mm) from Section 504 of the *International Building Code*.

*EBH* = Existing building height in feet (mm).

*AS* = Allowable height in stories from Section 504 of the *International Building Code*.

*EBS* = Existing building height in stories.

*CF* = 1 if  $(AH) - (EBH)$  is positive.

*CF* = Construction type factor shown in Table 1401.6.6(2) if  $(AH) - (EBH)$  is negative.

**Note:** Where mixed occupancies are separated and individually evaluated as indicated in Section 1401.6, the values *AH*, *AS*, *EBH* and *EBS* shall be based on the height of the occupancy being evaluated.

#### 1401.6.2 Building area.

The value for building area shall be determined by the formula in Section 1401.6.2.2. Section 506 of the *International Building Code* and the formula in Section 1401.6.2.1 shall be used to determine the allowable area of the building. Subtract the actual building area from the allowable area and divide by 1,200 square feet (112 m<sup>2</sup>). Enter the area value and its sign (positive or negative) in Table 1401.7 under Safety Parameter 1401.6.2, Building Area, for fire safety, means of egress and general safety. In determining the area value, the maximum permitted positive value for area is 50 percent of the fire safety score as listed in Table 1401.8, Mandatory Safety Scores. Group I-2 occupancies shall be scored zero.

#### 1401.6.2.1 Allowable area formula.

The following formula shall be used in computing allowable area:

$$A_e = A_t + (NS \times I_f) \quad \text{(Equation 14-3)}$$

where:

- $A_e$  = Allowable building area per story (square feet).
- $A_t$  = Tabular allowable area factor (NS, S1, S13R, or SM value, as applicable in accordance with Table 506.2 of the *International Building Code*).
- NS = Tabular allowable area factor in accordance with Table 506.2 of the *International Building Code* for a nonsprinklered building (regardless of whether the building is sprinklered).
- $I_f$  = Area factor increase due to frontage as calculated in accordance with Section 506.3 of the *International Building Code*.

**401.6.2.2 Area formula.**

The following formula shall be used in computing the area value. Determine the area value for each occupancy floor area on a floor-by-floor basis. For each occupancy, choose the minimum area value of the set of values obtained for the particular occupancy.

$$\text{Area value}_i = \frac{\text{Allowable area}_i}{1200 \text{ square feet}} \left[ 1 - \left( \frac{\text{Actual area}_i}{\text{Allowable area}_i} + \dots + \frac{\text{Actual area}_n}{\text{Allowable area}_n} \right) \right] \quad \text{(Equation 14-4)}$$

where:

- $i$  = Value for an individual separated occupancy on a floor.
- $n$  = Number of separated occupancies on a floor.

**1401.6.3 Compartmentation.**

Evaluate the compartments created by fire barriers or horizontal assemblies which comply with Sections 1401.6.3.1 and 1401.6.3.2 and which are exclusive of the wall elements considered under Sections 1401.6.4 and 1401.6.5. Conforming compartments shall be figured as the net area and do not include shafts, chases, stairways, walls, or columns. Using Table 1401.6.3, determine the appropriate compartmentation value (CV) and enter that value into Table 1401.7 under Safety Parameter 1401.6.3, Compartmentation, for fire safety, means of egress, and general safety.

**TABLE 1401.6.3  
COMPARTMENTATION VALUES**

| OCCUPANCY      | CATEGORIES  |   |  |  |  |
|----------------|---|---|--|--|--|
|                | a<br>Compartment<br>size equal to or<br>greater than<br>15,000 square<br>feet | b<br>Compartment<br>size of 10,000<br>square feet | c<br>Compartment<br>size of 7,500<br>square feet | d<br>Compartment<br>size of 5,000<br>square feet | e<br>Compartment size<br>of 2,500 square<br>feet or less |
| A-1, A-3       | 0   | 6   | 10   | 14   | 18   |
| A-2            | 0   | 4   | 10   | 14   | 18   |
| A-4, B, E, S-2 | 0   | 5   | 10   | 15   | 20   |
| F, M, R, S-1   | 0   | 4   | 10   | 16   | 22   |

For SI: 1 square foot = 0.0929 m<sup>2</sup>

**1401.6.3.1 Wall construction.**

A wall used to create separate compartments shall be a fire barrier conforming to Section 707 of the *International Building Code* with a fire-resistance rating of not less than 2 hours. Where the building is not divided into more than one compartment, the compartment size shall be taken as the total floor area on all floors. Where there is more than one compartment within a story, each compartmented area on such story shall be provided with a horizontal exit conforming to Section 1026 of the *International Building Code*. The fire door serving as the horizontal exit between compartments shall be so installed, fitted, and gasketed that such fire door will provide a substantial barrier to the passage of smoke.

**1401.6.3.2 Floor/ceiling construction.**

A floor/ceiling assembly used to create compartments shall conform to Section 711 of the *International Building Code* and shall have a fire-resistance rating of not less than 2 hours.

**1401.6.4 Tenant and dwelling unit separations.**

Evaluate the fire-resistance rating of floors and walls separating tenants, including dwelling units, and not evaluated under Sections 1401.6.3 and 1401.6.5. Group 1-2 occupancies shall evaluate the rating of the separations between patient sleeping rooms.

Under the categories and occupancies in Table 1401.6.4, determine the appropriate value and enter that value in Table 1401.7 under Safety Parameter 1401.6.4, Tenant and Dwelling Unit Separation, for fire safety, means of egress, and general safety.

**TABLE 1401.6.4  
SEPARATION VALUES**

| OCCUPANCY                 | CATEGORIES |    |   |   |   |
|---------------------------|------------|----|---|---|---|
|                           | a          | b  | c | d | e |
| A-1                       | 0          | 0  | 0 | 0 | 1 |
| A-2                       | -5         | -3 | 0 | 1 | 3 |
| R                         | -4         | -2 | 0 | 2 | 4 |
| A-3, A-4, B, E, F, M, S-1 | -4         | -3 | 0 | 2 | 4 |
| I-2                       | 0          | 1  | 2 | 3 | 4 |
| S-2                       | -5         | -2 | 0 | 2 | 4 |

**1401.6.4.1 Categories.**

The categories for tenant and dwelling unit separations are:

1. ~~Category a—No fire partitions; incomplete fire partitions; no doors; doors not self-closing or automatic-closing.~~
2. ~~Category b—Fire partitions or floor assemblies with less than 1-hour fire-resistance ratings or not constructed in accordance with Section 708 or 711 of the *International Building Code*, respectively.~~
3. ~~Category c—Fire partitions with 1-hour or greater fire-resistance ratings constructed in accordance with Section 708 of the *International Building Code* and floor assemblies with 1-hour but less than 2-hour fire-resistance ratings constructed in accordance with Section 711 of the *International Building Code* or with only one tenant within the floor area.~~
4. ~~Category d—Fire barriers with 1-hour but less than 2-hour fire-resistance ratings constructed in accordance with Section 707 of the *International Building Code* and floor assemblies with 2-hour or greater fire-resistance ratings constructed in accordance with Section 711 of the *International Building Code*.~~
5. ~~Category e—Fire barriers and floor assemblies with 2-hour or greater fire-resistance ratings and constructed in accordance with Sections 707 and 711 of the *International Building Code*, respectively.~~

**1401.6.5 Corridor walls.**

Evaluate the fire-resistance rating and degree of completeness of walls which create corridors serving the floor and that are constructed in accordance with Section 1020 of the *International Building Code*. This evaluation shall not include the wall elements considered under Sections 1401.6.3 and 1401.6.4. Under the categories and groups in Table 1401.6.5, determine the appropriate value and enter that value into Table

1401.7 under Safety Parameter 1401.6.5, Corridor Walls, for fire safety, means of egress, and general safety.

**TABLE 1401.6.5  
CORRIDOR WALL VALUES**

| OCCUPANCY         | CATEGORIES |     |   |   |
|-------------------|------------|-----|---|---|
|                   | a          | b   | c | d |
| A-1               | -10        | -4  | 0 | 2 |
| A-2               | -30        | -12 | 0 | 2 |
| A-3, F, M, R, S-1 | -7         | -3  | 0 | 2 |
| A-4, B, E, S-2    | -5         | -2  | 0 | 5 |
| I-2               | -10        | 0   | 1 | 2 |

a—Corridors not providing at least one-half the exit access travel distance or all occupants on a floor shall use Category b.

**1401.6.5.1 Categories.**

The categories for corridor walls are:

1. ~~Category a—No fire partitions; incomplete fire partitions; no doors; or doors not self-closing.~~
2. ~~Category b—Less than 1-hour fire-resistance rating or not constructed in accordance with Section 708.4 of the *International Building Code*.~~
3. ~~Category c—1-hour to less than 2-hour fire-resistance rating, with doors conforming to Section 716 of the *International Building Code* or without corridors as permitted by Section 1018 of the *International Building Code*.~~
4. ~~Category d—2-hour or greater fire-resistance rating, with doors conforming to Section 716 of the *International Building Code*.~~

**1401.6.6 Vertical openings.**

Evaluate the fire-resistance rating of interior exit stairways or ramps, hoistways, escalator openings, and other shaft enclosures within the building, and openings between two or more floors. Table 1401.6.6(1) contains the appropriate protection values. Multiply that value by the construction-type factor found in Table 1401.6.6(2). Enter the vertical opening value and its sign (positive or negative) in Table 1401.7 under Safety Parameter 1401.6.6, Vertical Openings, for fire safety, means of egress, and general safety. If the structure is a one-story building or if all the unenclosed vertical openings within the building conform to the requirements of Section 713 of the *International Building Code*, enter a value of 2. The maximum positive value for this requirement shall be 2.



**TABLE 1401.6.6(1)  
VERTICAL OPENING PROTECTION VALUE**

| <b>PROTECTION</b>          | <b>VALUE</b>                        |
|----------------------------|-------------------------------------|
| None (unprotected opening) | -2 times number of floors connected |
| Less than 1 hour           | -1 times number of floors connected |
| 1 to less than 2 hours     | 1                                   |
| 2 hours or more            | 2                                   |

**TABLE 1401.6.6(2)  
CONSTRUCTION-TYPE FACTOR**

| <b>F-A<br/>C-T<br/>O-R</b> | <b>TYPE OF CONSTRUCTION</b> |           |            |            |             |             |           |           |           |
|----------------------------|-----------------------------|-----------|------------|------------|-------------|-------------|-----------|-----------|-----------|
|                            | <b>IA</b>                   | <b>IB</b> | <b>IIA</b> | <b>IIB</b> | <b>IIIA</b> | <b>IIIB</b> | <b>IV</b> | <b>VA</b> | <b>VB</b> |
|                            | 1.2                         | 1.5       | 2.2        | 3.5        | 2.5         | 3.5         | 2.3       | 3.3       | 7         |

**1401.6.6.1 Vertical opening formula.**

The following formula shall be used in computing vertical opening value.

$$VO = PV \times CF \quad \text{(Equation 14-5)}$$

where:

*VO* = Vertical opening value.

*PV* = Protection value from Table 1401.6.6.(1).

*CF* = Construction type factor from Table 1401.6.6.(2).

**1401.6.7 HVAC systems.**

Evaluate the ability of the HVAC system to resist the movement of smoke and fire beyond the point of origin. Under the categories in Section 1401.6.7.1, determine the appropriate value and enter that value into Table 1401.7 under Safety Parameter 1401.6.7, HVAC Systems, for fire safety, means of egress, and general safety. Facilities in Group I-2 occupancies meeting Categories a, b or c shall be considered to fail the evaluation.

**1401.6.7.1 Categories.**

The categories for HVAC systems are:

1. ~~Category a—Plenums not in accordance with Section 602 of the *International Mechanical Code*.—10 points.~~
2. ~~Category b—Air movement in egress elements not in accordance with Section 1018.5 of the *International Building Code*.—5 points.~~
3. ~~Category c—Both Categories a and b are applicable. —15 points.~~
4. ~~Category d—Compliance of the HVAC system with Section 1020.5 of the *International Building Code* and Section 602 of the *International Mechanical Code*. 0 points.~~
5. ~~Category e—Systems serving one story; or a central boiler/chiller system without ductwork connecting two or more stories. +5 points.~~

**1401.6.8 Automatic fire detection.**

Evaluate the smoke detection capability based on the location and operation of automatic fire detectors in accordance with Section 907 of the *International Building Code* and the *International Mechanical Code*. Under the categories and occupancies in Table 1401.6.8, determine the appropriate value and enter that value into Table 1401.7 under Safety Parameter 1401.6.8, Automatic Fire Detection, for fire safety, means of egress, and general safety. Facilities in Group I-2 occupancies meeting Category a, b or c shall be considered to fail the evaluation.

**TABLE 1401.6.8  
AUTOMATIC FIRE DETECTION VALUES**

| OCCUPANCY              | CATEGORIES |    |    |   |   |   |
|------------------------|------------|----|----|---|---|---|
|                        | a          | b  | c  | d | e | f |
| A-1, A-3, F, M, R, S-1 | -10        | -5 | 0  | 2 | 6 | — |
| A-2                    | -25        | -5 | 0  | 5 | 9 | — |
| A-4, B, E, S-2         | -4         | -2 | 0  | 4 | 8 | — |
| I-2                    | NP         | NP | NP | 4 | 5 | 2 |

**1401.6.8.1 Categories.**

The categories for automatic fire detection are:

1. ~~Category a—None.~~

2. ~~Category b—Existing smoke detectors in HVAC systems and maintained in accordance with the *International Fire Code*.~~
3. ~~Category c—Smoke detectors in HVAC systems. The detectors are installed in accordance with the requirements for new buildings in the *International Mechanical Code*.~~
4. ~~Category d—Smoke detectors throughout all floor areas other than individual sleeping units, tenant spaces and dwelling units.~~
5. ~~Category e—Smoke detectors installed throughout the floor area.~~
6. ~~Category f—Smoke detectors in corridors only.~~

**1401.6.9 Fire alarm systems.**

Evaluate the capability of the fire alarm system in accordance with Section 907 of the *International Building Code*. Under the categories and occupancies in Table 1401.6.9, determine the appropriate value and enter that value into Table 1401.7 under Safety Parameter 1401.6.9, Fire Alarm System, for fire safety, means of egress, and general safety.

**TABLE 1401.6.9  
FIRE ALARM SYSTEM VALUES**

| OCCUPANCY                   | CATEGORIES |        |    |    |
|-----------------------------|------------|--------|----|----|
|                             | a          | a<br>b | c  | d  |
| A-1, A-2, A-3, A-4, B, E, R | -10        | -5     | 0  | 5  |
| F, M, S                     | 0          | 5      | 10 | 15 |
| I-2                         | -4         | 1      | 2  | 5  |

a. For buildings equipped throughout with an automatic sprinkler system, add 2 points for activation by a sprinkler water flow device.

**1401.6.9.1 Categories.**

The categories for fire alarm systems are:

1. ~~Category a—None.~~
2. ~~Category b—Fire alarm system with manual fire alarm boxes in accordance with Section 907.4 of the *International Building Code* and alarm notification appliances in accordance with Section 907.5.2 of the *International Building Code*.~~

3. ~~Category c—Fire alarm system in accordance with Section 907 of the *International Building Code*.~~
4. ~~Category d—Category c plus a required emergency voice/alarm communications system and a fire command station that conforms to Section 911 of the *International Building Code* and contains the emergency voice/alarm communications system controls, fire department communication system controls, and any other controls specified in Section 911 of the *International Building Code* where those systems are provided.~~

**1401.6.10 Smoke control.**

Evaluate the ability of a natural or mechanical venting, exhaust, or pressurization system to control the movement of smoke from a fire. Under the categories and occupancies in Table 1401.6.10, determine the appropriate value and enter that value into Table 1401.7 under Safety Parameter 1401.6.10, Smoke Control, for means of egress and general safety.

**TABLE 1401.6.10  
SMOKE CONTROL VALUES**

| OCCUPANCY     | CATEGORIES |        |        |        |        |        |
|---------------|------------|--------|--------|--------|--------|--------|
|               | a          | b      | c      | d      | e      | f      |
| A-1, A-2, A-3 | 0          | 1      | 2      | 3      | 6      | 6      |
| A-4, E        | 0          | 0      | 0      | 1      | 3      | 5      |
| B, M, R       | 0          | a<br>2 | a<br>3 | a<br>3 | a<br>3 | a<br>4 |
| F, S          | 0          | a<br>2 | a<br>2 | a<br>3 | a<br>3 | a<br>3 |
| I-2           | -4         | 0      | 0      | 0      | 3      | 0      |

a.—This value shall be 0 if compliance with Category d or e in Section 1401.6.8.1 has not been obtained.

**1401.6.10.1 Categories.**

The categories for smoke control are:

1. ~~Category a—None.~~
2. ~~Category b—The building is equipped throughout with an automatic sprinkler system. Openings are provided in exterior walls at the rate of 20 square feet (1.86 m<sup>2</sup>) per 50 linear feet (15 240 mm) of exterior wall in each story and distributed around the building perimeter at intervals not exceeding 50 feet (15 240 mm). Such openings shall be readily operable from the inside without a key or separate tool and shall be provided with ready access thereto. In lieu of operable openings, clearly and permanently marked tempered glass panels shall be used.~~

3. ~~Category c—One enclosed exit stairway, with ready access thereto, from each occupied floor of the building. The stairway has operable exterior windows, and the building has openings in accordance with Category b.~~
4. ~~Category d—One smokeproof enclosure and the building has openings in accordance with Category b.~~
5. ~~Category e—The building is equipped throughout with an automatic sprinkler system. Each floor area is provided with a mechanical air-handling system designed to accomplish smoke containment. Return and exhaust air shall be moved directly to the outside without recirculation to other floor areas of the building under fire conditions. The system shall exhaust not less than six air changes per hour from the floor area. Supply air by mechanical means to the floor area is not required. Containment of smoke shall be considered as confining smoke to the floor area involved without migration to other floor areas. Any other tested and approved design that will adequately accomplish smoke containment is permitted.~~
6. ~~Category f—Each stairway shall be one of the following: a smokeproof enclosure in accordance with Section 1023.11 of the *International Building Code*; pressurized in accordance with Section 909.20.5 of the *International Building Code*; or shall have operable exterior windows.~~

**1401.6.11 Means of egress capacity and number.**

Evaluate the means of egress capacity and the number of exits available to the building occupants. In applying this section, the means of egress are required to conform to the following sections of the *International Building Code*: 1003.7, 1004, 1005.1, 1006, 1007, 1016.2, 1025.1, 1028.2, 1028.5, 1029.2, 1029.3, 1029.4 and 1030. The number of exits credited is the number that is available to each occupant of the area being evaluated. Existing fire escapes shall be accepted as a component in the means of egress when conforming to Section 405.

Under the categories and occupancies in Table 1401.6.11, determine the appropriate value and enter that value into Table 1401.7 under Safety Parameter 1401.6.11, Means of Egress Capacity, for means of egress and general safety.

**TABLE 1401.6.11  
MEANS OF EGRESS VALUES<sup>a</sup>**

| OCCUPANCY                     | CATEGORIES |   |   |   |    |
|-------------------------------|------------|---|---|---|----|
|                               | a          | b | c | d | e  |
| A-1, A-2,<br>A-3, A-4, E, I-2 | -10        | 0 | 2 | 8 | 10 |
| M                             | -3         | 0 | 1 | 2 | 4  |
| B, F, S                       | -1         | 0 | 0 | 0 | 0  |
| R                             | -3         | 0 | 0 | 0 | 0  |

a. ~~The values indicated are for buildings six stories or less in height. For buildings over six stories above grade plane, add an additional 10 points.~~

**1401.6.11.1 Categories.**

The categories for means of egress capacity and number of exits are:

- ~~1. Category a—Compliance with the minimum required means of egress capacity or number of exits is achieved through the use of a fire escape in accordance with Section 405.~~
- ~~2. Category b—Capacity of the means of egress complies with Section 1004 of the *International Building Code*, and the number of exits complies with the minimum number required by Section 1021 of the *International Building Code*.~~
- ~~3. Category c—Capacity of the means of egress is equal to or exceeds 125 percent of the required means of egress capacity, the means of egress complies with the minimum required width dimensions specified in the *International Building Code*, and the number of exits complies with the minimum number required by Section 1006 of the *International Building Code*.~~
- ~~4. Category d—The number of exits provided exceeds the number of exits required by Section 1006 of the *International Building Code*. Exits shall be located a distance apart from each other equal to not less than that specified in Section 1015.2 of the *International Building Code*.~~
- ~~5. Category e—The area being evaluated meets both Categories c and d.~~

**1401.6.12 Dead ends.**

In spaces required to be served by more than one means of egress, evaluate the length of the exit access travel path in which the building occupants are confined to a single path of travel. Under the categories and occupancies in Table 1401.6.12, determine the appropriate value and enter that value into Table 1401.7 under Safety Parameter 1401.6.12, Dead Ends, for means of egress and general safety.

**TABLE 1401.6.12  
DEAD-END VALUES**

| OCCUPANCY                    | CATEGORIES <sup>a</sup> |   |   |    |
|------------------------------|-------------------------|---|---|----|
|                              | a                       | b | c | d  |
| A-1, A-3, A-4, B, F, M, R, S | -2                      | 0 | 2 | -4 |
| A-2, E                       | -2                      | 0 | 2 | -4 |
| I-2                          | -2                      | 0 | 2 | -6 |

a. For dead end distances between categories, the dead end value shall be obtained by linear interpolation.

**1401.6.12.1 Categories.**

The categories for dead ends are:

1. ~~Category a—Dead end of 35 feet (10 670 mm) in nonsprinklered buildings or 70 feet (21 340 mm) in sprinklered buildings.~~
2. ~~Category b—Dead end of 20 feet (6096 mm); or 50 feet (15 240 mm) in Group B in accordance with Section 1020.4, Exception 2, of the *International Building Code*.~~
3. ~~Category c—No dead ends; or ratio of length to width (l/w) is less than 2.5:1.~~
4. ~~Category d—Dead ends exceeding Category a.~~

**1401.6.13 Maximum exit access travel distance to an exit.**

~~Evaluate the length of exit access travel to an approved exit. Determine the appropriate points in accordance with the following equation and enter that value into Table 1401.7 under Safety Parameter 1401.6.13, Maximum Exit Access Travel Distance for means of egress and general safety. The maximum allowable exit access travel distance shall be determined in accordance with Section 1016.1 of the *International Building Code*.~~

$$\text{Points} = 20 \times \frac{\text{Maximum allowable travel distance} - \text{Maximum actual travel distance}}{\text{Maximum allowable travel distance}} \quad \text{(Equation 14-6)}$$

**1401.6.14 Elevator control.**

~~Evaluate the passenger elevator equipment and controls that are available to the fire department to reach all occupied floors. Emergency recall and in-car operation of elevators shall be provided in accordance with the *International Fire Code*. Under the categories and occupancies in Table 1401.6.14, determine the appropriate value and enter that value into Table 1401.7 under Safety Parameter 1401.6.14, Elevator Control, for fire safety, means of egress and general safety. The values shall be zero for a single-story building.~~

**TABLE 1401.6.14  
ELEVATOR CONTROL VALUES**

| ELEVATOR TRAVEL   | CATEGORIES |    |   |    |
|---|------------|----|---|----|
|   | a          | b  | c | d  |
| Less than 25 feet of travel above or below the primary level of elevator access for emergency fire-fighting or rescue personnel | -2         | 0  | 0 | +2 |
| Travel of 25 feet or more above or below the primary level of elevator access for emergency fire-fighting or rescue personnel   | -4         | NP | 0 | +4 |

For SI: 1 foot = 304.8 mm.  
 NP = Not permitted.

**1401.6.14.1 Categories.**

The categories for elevator controls are:

1. ~~Category a—No elevator.~~
2. ~~Category b—Any elevator without Phase I emergency recall operation and Phase II emergency in-car operation.~~
3. ~~Category c—All elevators with Phase I emergency recall operation and Phase II emergency in-car operation as required by the *International Fire Code*.~~
4. ~~Category d—All meet Category c; or Category b where permitted to be without Phase I emergency recall operation and Phase II emergency in-car operation; and at least one elevator that complies with new construction requirements serves all occupied floors.~~

**1401.6.15 Means of egress emergency lighting.**

Evaluate the presence of and reliability of means of egress emergency lighting. Under the categories and occupancies in Table 1401.6.15, determine the appropriate value and enter that value into Table 1401.7 under Safety Parameter 1401.6.15, Means of Egress Emergency Lighting, for means of egress and general safety.

**TABLE 1401.6.15  
 MEANS-OF-EGRESS EMERGENCY LIGHTING VALUES**

| NUMBER OF EXITS REQUIRED BY SECTION 1015 OF THE<br><i>INTERNATIONAL BUILDING CODE</i> | CATEGORIES |   |   |
|---|------------|---|---|
|   | a          | b | c |
| Two or more exits   | NP         | 0 | 4 |
| Minimum of one exit   | 0          | 1 | 1 |

NP = Not permitted.

**1401.6.15.1 Categories.**

The categories for means of egress emergency lighting are:

1. ~~Category a—Means of egress lighting and exit signs not provided with emergency power in accordance with Section 2702 of the *International Building Code*.~~



~~2. Category b—Means of egress lighting and exit signs provided with emergency power in accordance with Section 2702 of the *International Building Code*.~~

~~3. Category c—Emergency power provided to means of egress lighting and exit signs, which provides protection in the event of power failure to the site or building.~~

**1401.6.16 Mixed occupancies.**

~~Where a building has two or more occupancies that are not in the same occupancy classification, the separation between the mixed occupancies shall be evaluated in accordance with this section. Where there is no separation between the mixed occupancies or the separation between mixed occupancies does not qualify for any of the categories indicated in Section 1401.6.16.1, the building shall be evaluated as indicated in Section 1401.6, and the value for mixed occupancies shall be zero. Under the categories and occupancies in Table 1401.6.16, determine the appropriate value and enter that value into Table 1401.7 under Safety Parameter 1401.6.16, Mixed Occupancies, for fire safety and general safety. For buildings without mixed occupancies, the value shall be zero. Facilities in Group I-2 occupancies meeting Category a shall be considered to fail the evaluation.~~

**TABLE 1401.6.16  
MIXED OCCUPANCY VALUES<sup>a</sup>**

| OCCUPANCY               | CATEGORIES |   |    |
|-------------------------|------------|---|----|
|                         | a          | b | c  |
| A-1, A-2, R             | -10        | 0 | 10 |
| A-3, A-4, B, E, F, M, S | -5         | 0 | 5  |
| I-2                     | NP         | 0 | 5  |

NP = not permitted.

a. For fire resistance ratings between categories, the value shall be obtained by linear interpolation.

**1401.6.16.1 Categories.**

The categories for mixed occupancies are:

~~1. Category a—Occupancies separated by minimum 1-hour fire barriers or minimum 1-hour horizontal assemblies, or both.~~

~~2. Category b—Separations between occupancies in accordance with Section 508.4 of the *International Building Code*.~~

~~3. Category c—Separations between occupancies having a fire resistance rating of not less than twice that required by Section 508.4 of the *International Building Code*.~~

**1401.6.17 Automatic sprinklers.**

Evaluate the ability to suppress a fire based on the installation of an automatic sprinkler system in

accordance with Section 903.3.1.1 of the *International Building Code*. “Required sprinklers” shall be based on the requirements of this code. Under the categories and occupancies in Table 1401.6.17, determine the appropriate value and enter that value into Table 1401.7 under Safety Parameter 1401.6.17, Automatic Sprinklers, for fire safety, means of egress divided by 2, and general safety. High-rise buildings defined in Chapter 2 of the *International Building Code* that undergo a change of occupancy to Group R shall be equipped throughout with an automatic sprinkler system in accordance with Section 403 of the *International Building Code* and Chapter 9 of the *International Building Code*. Facilities in Group I-2 occupancies meeting Category a, b, c or f shall be considered to fail the evaluation.

**TABLE 1401.6.17  
SPRINKLER SYSTEM VALUES**

| OCCUPANCY              | CATEGORIES |    |    |   |    |    |
|------------------------|------------|----|----|---|----|----|
|                        | a          | b  | c  | d | e  | f  |
| A-1, A-3, F, M, R, S-1 | -6         | -3 | 0  | 2 | 4  | 6  |
| A-2                    | -4         | -2 | 0  | 1 | 2  | 4  |
| A-4, B, E, S-2         | -12        | -6 | 0  | 3 | 6  | 12 |
| I-2                    | NP         | NP | NP | 8 | 10 | NP |

NP – not permitted.

a. These options cannot be taken if Category a in Section 1401.6.18 is used.

**1401.6.17.1 Categories.**

The categories for automatic sprinkler system protection are:

1. Category a – Sprinklers are required throughout; sprinkler protection is not provided or the sprinkler system design is not adequate for the hazard protected in accordance with Section 903 of the *International Building Code*.
2. Category b – Sprinklers are required in a portion of the building; sprinkler protection is not provided or the sprinkler system design is not adequate for the hazard protected in accordance with Section 903 of the *International Building Code*.
3. Category c – Sprinklers are not required; none are provided.
4. Category d – Sprinklers are required in a portion of the building; sprinklers are provided in such portion; the system is one that complied with the code at the time of installation and is maintained and supervised in accordance with Section 903 of the *International Building Code*.
5. Category e – Sprinklers are required throughout; sprinklers are provided throughout in accordance with Chapter 9 of the *International Building Code*.

~~6. Category f—Sprinklers are not required throughout; sprinklers are provided throughout in accordance with Chapter 9 of the *International Building Code*.~~

**1401.6.18 Standpipes.**

~~Evaluate the ability to initiate attack on a fire by a making supply of water available readily through the installation of standpipes in accordance with Section 905 of the *International Building Code*. “Required Standpipes” shall be based on the requirements of the *International Building Code*. Under the categories and occupancies in Table 1401.6.18, determine the appropriate value and enter that value into Table 1401.7 under Safety Parameter 1401.6.18, Standpipes, for fire safety, means of egress, and general safety.~~

**TABLE 1401.6.18  
STANDPIPE SYSTEM VALUES**

| OCCUPANCY              | CATEGORIES |   |   |    |
|------------------------|------------|---|---|----|
|                        | a          | b | c | d  |
| A-1, A-3, F, M, R, S-1 | -6         | 0 | 4 | 6  |
| A-2                    | -4         | 0 | 2 | 4  |
| A-4, B, E, S-2         | -12        | 0 | 6 | 12 |
| I-2                    | -2         | 0 | 1 | 2  |

~~a. This option cannot be taken if Category a or Category b in Section 1401.6.17 is used.~~

**1401.6.18.1 Standpipe categories.**

~~The categories for standpipe systems are:~~

- ~~1. Category a—Standpipes are required; standpipe is not provided or the standpipe system design is not in compliance with Section 905.3 of the *International Building Code*.~~
- ~~2. Category b—Standpipes are not required; none are provided.~~
- ~~3. Category c—Standpipes are required; standpipes are provided in accordance with Section 905 of the *International Building Code*.~~
- ~~4. Category d—Standpipes are not required; standpipes are provided in accordance with Section 905 of the *International Building Code*.~~

**1401.6.19 Incidental uses.**

~~Evaluate the protection of incidental uses in accordance with Section 509.4.2 of the *International Building*~~

~~Code. Do not include those where this code requires automatic sprinkler systems throughout the building including covered and open mall buildings, high-rise buildings, public garages and unlimited area buildings. Assign the lowest score from Table 1401.6.19 for the building or floor area being evaluated and enter that value into Table 1401.7 under Safety Parameter 1401.6.19, Incidental Uses, for fire safety, means of egress and general safety. If there are no specific occupancy areas in the building or floor area being evaluated, the value shall be zero.~~

**TABLE 1401.6.19  
INCIDENTAL USE AREA VALUES**

| PROTECTION REQUIRED BY TABLE 509 OF THE INTERNATIONAL BUILDING CODE | PROTECTION PROVIDED |        |    |             |               |         |                |
|---|---------------------|--------|----|-------------|---------------|---------|----------------|
|   | None                | 1 hour | AS | AS with CRS | 1 hour and AS | 2 hours | 2 hours and AS |
| 2 hours and AS  | -4                  | -3     | -2 | -2          | -1            | -2      | 0              |
| 2 hours, or 1 hour and AS   | -3                  | -2     | -1 | -1          | 0             | 0       | 0              |
| 1 hour and AS   | -3                  | -2     | -1 | -1          | 0             | -1      | 0              |
| 1 hour  | -1                  | 0      | -1 | -1          | 0             | 0       | 0              |
| 1 hour, or AS with CRS  | -1                  | 0      | -1 | -1          | 0             | 0       | 0              |
| AS with CRS   | -1                  | -1     | -1 | -1          | 0             | -1      | 0              |
| 1 hour or AS  | -1                  | 0      | 0  | 0           | 0             | 0       | 0              |

AS = Automatic sprinkler system;

CRS = Construction capable of resisting the passage of smoke (see IBC Section 509.4.2 of the International Building Code).

**Note:** For Table 1401.7, see page 75.

**1401.6.20 Smoke compartmentation.**

~~Evaluate the smoke compartments for compliance with Section 407.5 of the International Building Code. Under the categories and occupancies in Table 1401.6.20, determine the appropriate smoke compartmentation value (SCV) and enter that value into Table 1401.7 under Safety Parameter 1401.6.20, Smoke Compartmentation, for fire safety, means of egress and general safety. Facilities in Group I-2 occupancies meeting Category b or c shall be considered to fail the evaluation.~~

**TABLE 1401.6.20  
SMOKE COMPARTMENTATION VALUES**

| OCCUPANCY                 | CATEGORIES <sup>a</sup> |   |   |
|---------------------------|-------------------------|---|---|
|                           | a                       | b | c |
| A, B, E,<br>F, M, R and S | 0                       | 0 |   |

|     |   |    |    |
|-----|---|----|----|
| I-2 | 0 | NP | NP |
|-----|---|----|----|

For SI: 1 square foot = 0.093 m<sup>2</sup>.

NP = Not permitted.

a. For areas between categories, the smoke compartmentation value shall be obtained by linear interpolation.

**1401.6.20.1 Categories.**

Categories for smoke compartment size are:

1. ~~Category a—Smoke compartment size is equal to or less than 22,500 square feet (2092 m<sup>2</sup>).~~
2. ~~Category b—Smoke compartment size is greater than 22,500 square feet (2092 m<sup>2</sup>).~~
3. ~~Category c—Smoke compartments are not provided.~~

**1401.6.21 Patient ability, concentration, smoke compartment location and ratio to attendant.**

In I-2 occupancies, the ability of patients, their concentration and ratio to attendants shall be evaluated and applied in accordance with this section. Evaluate each smoke compartment using the categories in Sections 1401.6.21.1, 1401.6.21.2 and 1401.6.21.3 and enter the value in Table 1401.8. To determine the safety factor, multiply the three values together, if the sum is 9 or greater, compliance has failed.

**1401.6.21.1 Patient ability for self-preservation.**

Evaluate the ability of the patients for self-preservation in each smoke compartment in an emergency. Under the categories and occupancies in Table 1401.6.21.1 determine the appropriate value and enter that value in Table 1401.7 under Safety Parameter 1401.6.21.1, Patient Ability for Self-preservation, for means of egress and general safety.

**TABLE 1401.6.21.1  
PATIENT ABILITY VALUES**

| OCCUPANCY | CATEGORIES |   |   |
|-----------|------------|---|---|
|           | a          | b | c |
| I-2       | 1          | 2 | 3 |

**1401.6.21.1.1 Categories.**

The categories for patient ability for self-preservation are:

1. ~~Category a—(mobile) Patients are capable of self-preservation without assistance.~~

2. ~~Category c—(not mobile) Patients rely on assistance for evacuation or relocation.~~

3. ~~Category d—(not movable) Patients cannot be evacuated or relocated.~~

**1401.6.21.2 Patient concentration.**

Evaluate the concentration of patients in each smoke compartment under Section 1401.6.21.2. Under the categories and occupancies in Table 1401.6.21.2 determine the appropriate value and enter that value in Table 1401.7 under Safety Parameter 1401.6.21.2, Patient Concentration, for means of egress and general safety.

**TABLE 1401.6.21.2  
PATIENT CONCENTRATION VALUES**

| OCCUPANCY | CATEGORIES |   |   |
|-----------|------------|---|---|
|           | a          | b | c |
| 1-2       | 1          | 2 | 3 |

**1401.6.21.3 Attendant-to-patient ratio.**

Evaluate the attendant-to-patient ratio for each compartment under Section 1401.6.21.3. Under the categories and occupancies in Table 1401.6.21.3 determine the appropriate value and enter that value in Table 1401.7 under Safety Parameter 1401.6.21.3, Attendant-to-patient Ratio, for means of egress and general safety.

**TABLE 1401.6.21.3  
ATTENDANT TO PATIENT RATIO VALUES**

| OCCUPANCY | CATEGORIES |   |   |
|-----------|------------|---|---|
|           | a          | b | c |
| 1-2       | 1          | 2 | 3 |

**1401.6.21.3.1 Categories.**

The categories for attendant-to-patient concentrations are:

1. ~~Category a—attendant-to-patient concentrations is 1:5.~~

2. ~~Category b—attendant-to-patient concentrations is 1:6 to 1:10.~~

3. ~~Category c—attendant-to-patient concentrations is greater than 1:10 or no patients.~~

**1401.7 Building score.**

After determining the appropriate data from Section 1401.6, enter those data in Table 1401.7 and total the building score.

**TABLE 1401.7  
SUMMARY SHEET-BUILDING CODE**

|  |  |
|--|--|
| Existing occupancy: _____                                    | Proposed occupancy: _____                          |
| Year building was constructed:<br>_____                      | Number of stories: _____ Height in feet: _____     |
| Type of construction:<br>_____                               | Area per floor: _____                              |
| Percentage of open perimeter increase: _____%                |  |
| Completely suppressed: Yes _____ No _____                    | Corridor wall rating: _____<br>Type: _____         |
| Compartmentation: Yes _____ No _____                         | Required door closers: Yes _____ No _____<br>_____ |
| Fire resistance rating of vertical opening enclosures: _____ |  |
| Type of HVAC system: _____, serving number of floors: _____  |  |
| Automatic fire detection: Yes _____ No _____                 | Type and location: _____                           |
| Fire alarm system: Yes _____ No _____                        | Type: _____  |
| Smoke control: Yes _____ No _____                            | Type: _____  |
| Adequate exit routes: Yes _____ No _____                     | Dead ends: _____ Yes _____ No _____<br>_____       |
| Maximum exit access travel distance: _____                   | Elevator controls: Yes _____ No _____              |
| Means of egress emergency lighting: Yes _____ No _____       | Mixed occupancies: Yes _____ No _____<br>_____     |
| Standpipes Yes _____ No _____                                | Patient ability for self-preservation<br>_____     |
| Incidental use Yes _____ No _____                            | Patient concentration<br>_____                     |

Smoke  
compartmentation less

than 22,500 sq. feet  
(2092 m<sup>2</sup>)

Yes \_\_\_\_\_ No \_\_\_\_\_

Attendant to patient ratio

\_\_\_\_\_

| SAFETY PARAMETERS   | FIRE SAFETY (FS)                                   | MEANS OF EGRESS (ME)   | GENERAL SAFETY (GS) |
|---|--|--|---------------------|
| <del>1401.6.1 Building Height</del><br><del>1401.6.2 Building Area</del><br><del>1401.6.3 Compartmentation</del>  |  |  |                     |
| <del>1401.6.4 Tenant and Dwelling Unit Separations</del><br><del>1401.6.5 Corridor Walls</del><br><del>1401.6.6 Vertical Openings</del>   |  |  |                     |
| <del>1401.6.7 HVAC Systems</del><br><del>1401.6.8 Automatic Fire Detection</del><br><del>1401.6.9 Fire Alarm System</del>   |  |  |                     |
| <del>1401.6.10 Smoke control</del><br><del>1401.6.11 Means of Egress</del><br><del>1401.6.12 Dead ends</del>  | <u>* * * *</u><br><u>* * * *</u><br><u>* * * *</u> |  |                     |
| <del>1401.6.13 Maximum Exit Access Travel Distance</del><br><del>1401.6.14 Elevator Control</del><br><del>1401.6.15 Means of Egress Emergency Lighting</del>  | <u>* * * *</u><br><u>* * * *</u>                   |  |                     |
| <del>1401.6.16 Mixed Occupancies</del><br><del>1401.6.17 Automatic Sprinklers</del><br><del>1401.6.18 Standpipes</del><br><del>1401.6.19 Incidental Use</del><br><del>1401.6.20 Smoke compartmentation</del><br><del>1401.6.21.1 Patient ability for self-preservation</del><br><del>1401.6.21.2 Patient concentration</del><br><del>1401.6.21.3 Attendant to patient Ratio</del> | <u>* * * *</u><br><u>* * * *</u><br><u>* * * *</u> | <u>* * * *</u><br><div style="text-align: center;">÷2=</div> |                     |
| <b>Building score—total value</b>   |  |  |                     |



\*\*\*No applicable value to be inserted.

**1401.8 Safety scores.**

The values in Table 1401.8 are the required mandatory safety scores for the evaluation process listed in Section 1401.6.

**TABLE 1401.8  
MANDATORY SAFETY SCORES<sup>a</sup>**

| OCCUPANCY | FIRE SAFETY (MFS) | MEANS OF EGRESS (MME) | GENERAL SAFETY (MGS) |
|-----------|-------------------|-----------------------|----------------------|
| A-1       | 20                | 31                    | 31                   |
| A-2       | 21                | 32                    | 32                   |
| A-3       | 22                | 33                    | 33                   |
| A-4, E    | 29                | 40                    | 40                   |
| B         | 30                | 40                    | 40                   |
| F         | 24                | 34                    | 34                   |
| I-2       | 19                | 34                    | 34                   |
| M         | 23                | 40                    | 40                   |
| R         | 21                | 38                    | 38                   |
| S-1       | 19                | 29                    | 29                   |
| S-2       | 29                | 39                    | 39                   |

- a. MFS = Mandatory Fire Safety.
- MME = Mandatory Means of Egress.
- MGS = Mandatory General Safety.

**1401.9 Evaluation of building safety.**

The mandatory safety score in Table 1401.8 shall be subtracted from the building score in Table 1401.7 for each category. Where the final score for any category equals zero or more, the building is in compliance with the requirements of this section for that category. Where the final score for any category is less than zero, the building is not in compliance with the requirements of this section.

**TABLE 1401.9  
EVALUATION FORMULAS<sup>a</sup>**

| FORMULA                     | T1401.7              | T1401.8               | SCORE | PASS                  | FAIL                  |
|-----------------------------|----------------------|-----------------------|-------|-----------------------|-----------------------|
| $\frac{FS - MFS}{0} \geq 0$ | $\frac{\quad}{(FS)}$ | $\frac{\quad}{(MFS)}$ | =     | $\frac{\quad}{\quad}$ | $\frac{\quad}{\quad}$ |

|                            |                            |                           |   |                  |                  |                  |
|----------------------------|----------------------------|---------------------------|---|------------------|------------------|------------------|
| <del>ME – MME</del><br>≥ 0 | <del>_____</del><br>(ME) – | <del>_____</del><br>(MME) | = | <del>_____</del> | <del>_____</del> | <del>_____</del> |
| <del>GS – MGS</del><br>≥ 0 | <del>_____</del><br>(GS) – | <del>_____</del><br>(MGS) | = | <del>_____</del> | <del>_____</del> | <del>_____</del> |

- a. ~~FS – Fire Safety.~~ MFS – Mandatory Fire Safety.  
~~ME – Means of Egress.~~ MME – Mandatory Means of Egress.  
~~GS – General Safety.~~ MGS – Mandatory Means of Safety.

**1401.9.1 Mixed occupancies.**

For mixed occupancies, the following provisions shall apply:

- ~~1. Where the separation between mixed occupancies does not qualify for any category indicated in Section 1401.6.16, the mandatory safety scores for the occupancy with the lowest general safety score in Table 1401.8 shall be utilized. (See Section 1401.6.)~~
- ~~2. Where the separation between mixed occupancies qualifies for any category indicated in Section 1401.6.16, the mandatory safety scores for each occupancy shall be placed against the evaluation scores for the appropriate occupancy.~~

## RELOCATED OR MOVED BUILDINGS

### SECTION 1401 GENERAL

**1401.1 Scope.** This chapter provides requirements for relocated or moved structures, including *relocatable buildings* as defined in Chapter 2.

**1401.1.1 Bleachers, grandstands and folding and telescopic seating.** Relocated or moved bleachers, grandstands and folding and telescopic seating shall comply with ICC 300.

**1401.2 Conformance.** The building shall be safe for human occupancy as determined by the *International Fire Code* and the *International Property Maintenance Code*. Any *repair, alteration or change of occupancy* undertaken within the moved structure shall comply with the requirements of this code applicable to the work being performed. Any field-fabricated elements shall comply with the requirements of the *International Building Code* or the *International Residential Code*, as applicable.

### SECTION 1402 REQUIREMENTS

**1402.1 Location on the lot.** The building shall be located on the lot in accordance with the requirements of the *International Building Code* or the *International Residential Code*, as applicable.

**[BS] 1402.2 Foundation.** The foundation system of relocated buildings shall comply with the *International Building Code* or the *International Residential Code*, as applicable.

**[BS] 1402.2.1 Connection to the foundation.** The connection of the relocated building to the foundation shall comply with the *International Building Code* or the *International Residential Code*, as applicable.

**[BS] 1402.3 Wind loads.** Buildings shall comply with *International Building Code* or *International Residential Code* wind provisions, as applicable.

**Exceptions:**

1. Detached one- and two-family dwellings and Group U occupancies where wind loads at the new location are not higher than those at the previous location.
2. Structural elements whose stress is not increased by more than 10 percent.

**[BS] 1402.4 Seismic loads.** Buildings shall comply with *International Building Code* or *International Residential Code* seismic provisions at the new location, as applicable.

**Exceptions:**

1. Structures in Seismic Design Categories A and B and detached one- and two-family dwellings in Seismic Design Categories A, B and C where the seismic loads at the new location are not higher than those at the previous location.
2. Structural elements whose stress is not increased by more than 10 percent.

**[BS] 1402.5 Snow loads.** Structures shall comply with *International Building Code* or *International Residential Code* snow loads, as applicable, where snow loads at the new location are higher than those at the previous location.

**Exception:** Structural elements whose stress is not increased by more than 5 10 percent.

**[BS] 1402.6 Flood hazard areas.** If relocated or moved into a *flood hazard area*, structures shall comply with Section 1612 of the *International Building Code*, or Section R322 of the *International Residential Code*, as applicable.

**[BS] 1402.7 Required inspection and repairs.** The *code official* shall be authorized to inspect, or to require *approved* professionals to inspect at the expense of the owner, the various structural parts of a relocated building to verify that structural components and connections have not sustained structural damage. Any *repairs* required by the *code official* as a result of such inspection shall be made prior to the final approval.

# CHAPTER 15

## CONSTRUCTION SAFEGUARDS

### SECTION 1501 GENERAL

#### **[BG] 1501.1 Scope.**

The provisions of this chapter shall govern safety during construction that is under the jurisdiction of this code and the protection of adjacent public and private properties.

#### **[BG] 1501.2 Storage and placement.**

Construction equipment and materials shall be stored and placed so as not to endanger the public, the workers or adjoining property for the duration of the construction project.

**\*\*** **[BS] 1501.2.1 Structural and construction loads.** Structural roof components shall be capable of supporting the roof-covering system and the material and equipment loads that will be encountered during installation of the system.

#### **[BG] 1501.3 Alterations, repairs, and additions.**

Required exits, existing structural elements, fire protection devices, and sanitary safeguards shall be maintained at all times during *alterations*, *repairs*, or *additions* to any building or structure.

#### **Exceptions:**

1. When such required elements or devices are being altered or repaired, adequate substitute provisions shall be made.
2. ~~When~~ Maintenance of such elements and devices is not required where the *existing building* is not occupied.

#### **[BG] 1501.4 Manner of removal.**

Waste materials shall be removed in a manner which prevents injury or damage to persons, adjoining properties, and public rights-of-way.

#### **[BG] 1501.5 Fire safety during construction.**

Fire safety during construction shall comply with the applicable requirements of the *International Building Code* and the applicable provisions of Chapter 33 of the *International Fire Code*.

**[BS] 1501.6 Protection of pedestrians.**

Pedestrians shall be protected during construction and demolition activities as required by Sections 1501.6.1 through 1501.6.7 and Table 1501.6. Signs shall be provided to direct pedestrian traffic.

**[BS] TABLE 1501.6  
PROTECTION OF PEDESTRIANS**

| HEIGHT OF CONSTRUCTION | DISTANCE OF CONSTRUCTION TO LOT LINE   | TYPE OF PROTECTION REQUIRED |
|------------------------|--|-----------------------------|
| 8 feet or less         | Less than 5 feet   | Construction railings       |
|                        | 5 feet or more   | None                        |
| More than 8 feet       | Less than 5 feet   | Barrier and covered walkway |
|                        | 5 feet or more, but not more than one-fourth the height of construction        | Barrier and covered walkway |
|                        | 5 feet or more, but between one-fourth and one-half the height of construction | Barrier                     |
|                        | 5 feet or more, but exceeding one-half the height of construction              | None                        |

For SI: 1 foot = 304.8 mm.

**[BS] 1501.6.1 Walkways.**

A walkway shall be provided for pedestrian travel in front of every construction and demolition site unless the applicable governing authority authorizes the sidewalk to be fenced or closed. Walkways shall be of sufficient width to accommodate the pedestrian traffic, but in no case shall they be less than 4 feet (1219 mm) in width. Walkways shall be provided with a durable walking surface. Walkways shall be accessible in accordance with Chapter 11 of the *International Building Code* and shall be designed to support all imposed loads and in no case shall the design live load be less than 150 pounds per square foot (psf) (7.2 kN/m<sup>2</sup>).

**[BS] 1501.6.2 Directional barricades.**

Pedestrian traffic shall be protected by a directional barricade where the walkway extends into the street. The directional barricade shall be of sufficient size and construction to direct vehicular traffic away from the pedestrian path.

**[BS] 1501.6.3 Construction railings.**

Construction railings shall be at least 42 inches (1067 mm) in height and shall be sufficient to direct pedestrians around construction areas.

**[BS] 1501.6.4 Barriers.**

Barriers shall be a minimum of 8 feet (2438 mm) in height and shall be placed on the side of the walkway nearest the construction. Barriers shall extend the entire length of the construction site. Openings in such barriers shall be protected by doors which are normally kept closed.

**[BS] 1501.6.4.1 Barrier design.**

Barriers shall be designed to resist loads required in Chapter 16 of the *International Building Code* unless constructed as follows:

1. Barriers shall be provided with 2 × 4 top and bottom plates.
2. The barrier material shall be a minimum of  $\frac{3}{4}$  inch (19.1 mm) boards or  $\frac{1}{4}$  inch (6.4 mm) wood structural use panels.
3. Wood structural use panels shall be bonded with an adhesive identical to that for exterior wood structural use panels.
4. Wood structural use panels  $\frac{1}{4}$  inch (6.4 mm) or  $\frac{1}{16}$  inch (1.6 mm) in thickness shall have studs spaced not more than 2 feet (610 mm) on center.
5. Wood structural use panels  $\frac{3}{8}$  inch (9.5 mm) or  $\frac{1}{2}$  inch (12.7 mm) in thickness shall have studs spaced not more than 4 feet (1219 mm) on center, provided a 2-inch by 4-inch (51 mm by 102 mm) stiffener is placed horizontally at the mid-height where the stud spacing exceeds 2 feet (610 mm) on center.
6. Wood structural use panels  $\frac{5}{8}$  inch (15.9 mm) or thicker shall not span over 8 feet (2438 mm).

**[BS] 1501.6.5 Covered walkways.**

Covered walkways shall have a minimum clear height of 8 feet (2438 mm) as measured from the floor surface to the canopy overhead. Adequate lighting shall be provided at all times. Covered walkways shall be designed to support all imposed loads. In no case shall the design live load be less than 150 psf (7.2 kN/m<sup>2</sup>) for the entire structure.

**Exception:** Roofs and supporting structures of covered walkways for new, light-frame construction not exceeding two stories above grade plane are permitted to be designed for a live load of 75 psf (3.6 kN/m<sup>2</sup>) or the loads imposed on them, whichever is greater. In lieu of such designs, the roof and supporting structure of a covered walkway are permitted to be constructed as follows:

1. Footings shall be continuous 2 × 6 members.
2. Posts not less than 4 × 6 shall be provided on both sides of the roof and spaced not more than 12 feet (3658 mm) on center.

3. Stringers not less than 4 × 12 shall be placed on edge upon the posts.
4. Joists resting on the stringers shall be at least 2 × 8 and shall be spaced not more than 2 feet (610 mm) on center.
5. The deck shall be planks at least 2 inches (51 mm) thick or wood structural panels with an exterior exposure durability classification at least  $\frac{23}{32}$  inch (18.3 mm) thick nailed to the joists.
6. Each post shall be knee-braced to joists and stringers by 2 × 4 minimum members 4 feet (1219 mm) long.
7. A 2 × 4 minimum curb shall be set on edge along the outside edge of the deck.

**[BS] 1501.6.6 Repair, maintenance and removal.**

Pedestrian protection required by Section 1501.6 shall be maintained in place and kept in good order for the entire length of time pedestrians may be endangered. The owner or the owner's agent, upon the completion of the construction activity, shall immediately remove walkways, debris and other obstructions and leave such public property in as good a condition as it was before such work was commenced.

**[BS] 1501.6.7 Adjacent to excavations.**

Every excavation on a site located 5 feet (1524 mm) or less from the street lot line shall be enclosed with a barrier not less than 6 feet (1829 mm) high. Where located more than 5 feet (1524 mm) from the street lot line, a barrier shall be erected when required by the *code official*. Barriers shall be of adequate strength to resist wind pressure as specified in Chapter 16 of the *International Building Code*.

**1501.7 Facilities required.**

Sanitary facilities shall be provided during construction or demolition activities in accordance with the *International Plumbing Code*.

## **SECTION 1502 PROTECTION OF ADJOINING PROPERTY**

**[BS] 1502.1 Protection required.**

Adjoining public and private property shall be protected from damage during construction and demolition work. Protection must be provided for footings, foundations, party walls, chimneys, skylights and roofs. Provisions shall be made to control water runoff and erosion during construction or demolition activities. The person making or causing an excavation to be made shall provide written notice to the owners of adjoining buildings advising them that the excavation is to be made and that the adjoining buildings should be protected. Said notification shall be delivered not less than 10 days prior to the scheduled starting date of the excavation.

**[BS] 1502.2 Excavation retention systems.** Where a retention system is used to provide support of an excavation for protection of adjacent structures, the system shall conform to the requirements in Section 1502.2.1 through 1502.2.3.

**[BS] 1502.2.1 Excavation retention system design.** Excavation retention systems shall be designed by a *registered design professional* to provide vertical and lateral support.

**[BS] 1502.2.2 Excavation retention system monitoring.** The retention system design shall include requirements for monitoring of the system and adjacent structures for horizontal and vertical movement.

**[BS] 1502.2.3 Retention system removal.** Elements of the system shall only be removed or decommissioned where adequate replacement support is provided by backfill or by the new structure. Removal or decommissioning shall be performed in such a manner that protects the adjacent property.

## **SECTION 1503 TEMPORARY USE OF STREETS, ALLEYS AND PUBLIC PROPERTY**

### **[BG] 1503.1 Storage and handling of materials.**

The temporary use of streets or public property for the storage or handling of materials or equipment required for construction or demolition, and the protection provided to the public shall comply with the provisions of the applicable governing authority and this chapter.

### **[BG] 1503.2 Obstructions.**

Construction materials and equipment shall not be placed or stored so as to obstruct access to fire hydrants, standpipes, fire or police alarm boxes, catch basins or manholes, nor shall such material or equipment be located within 20 feet (6.1 m) of a street intersection, or placed so as to obstruct normal observations of traffic signals or to hinder the use of public transit loading platforms.

### **[BG] 1503.3 Utility fixtures.**

Building materials, fences, sheds or any obstruction of any kind shall not be placed so as to obstruct free approach to any fire hydrant, fire department connection, utility pole, manhole, fire alarm box, or catch basin, or so as to interfere with the passage of water in the gutter. Protection against damage shall be provided to such utility fixtures during the progress of the work, but sight of them shall not be obstructed.

## **SECTION 1504 FIRE EXTINGUISHERS**

### **[F] 1504.1 Where required.**

All structures under construction, *alteration*, or demolition shall be provided with not less than one approved portable fire extinguisher in accordance with Section 906 of the *International Fire Code* and sized for not less than ordinary hazard as follows:

1. At each stairway on all floor levels where combustible materials have accumulated.
2. In every storage and construction shed.
3. Additional portable fire extinguishers shall be provided where special hazards exist including, but not limited to, the storage and use of flammable and combustible liquids.



**[F] 1504.2 Fire hazards.**

The provisions of this code and of the *International Fire Code* shall be strictly observed to safeguard against all fire hazards attendant upon construction operations.

**SECTION 1505  
MEANS OF EGRESS**

**[BS] 1505.1 Stairways required.**

Where a building has been constructed to a building height of 50 feet (15 240 mm) or four stories, or where an *existing building* exceeding 50 feet (15 240 mm) in building height is altered, at least one temporary lighted stairway shall be provided unless one or more of the permanent stairways are erected as the construction progresses.

**[F] 1505.2 Maintenance of means of egress.**

Required means of egress shall be maintained at all times during construction, demolition, remodeling or *alterations* and *additions* to any building.

Exception: Approved temporary means of egress systems and facilities. Existing means of egress need not be maintained where *approved* temporary means of egress and accessible means of egress systems and facilities are provided.

**SECTION 1506  
STANDPIPE SYSTEMS**

**[F] 1506.1 Where required.**

In buildings required to have standpipes by Section 905.3.1 of the *International Building Code*, not less than one standpipe shall be provided for use during construction. Such standpipes shall be installed prior to construction exceeding 40 feet (12 192 mm) in height above the lowest level of fire department vehicle access. Such standpipe shall be provided with fire department hose connections at accessible locations adjacent to usable stairways. Such standpipes shall be extended as construction progresses to within one floor of the highest point of construction having secured decking or flooring.

**[F] 1506.2 Buildings being demolished.**

Where a building or portion of a building is being demolished and a standpipe is existing within such a building, such standpipe shall be maintained in an operable condition so as to be available for use by the fire department. Such standpipe shall be demolished with the building but shall not be demolished more than one floor below the floor being demolished.

**[F] 1506.3 Detailed requirements.**

Standpipes shall be installed in accordance with the provisions of Chapter 9 of the *International Building Code*.

**Exception:** Standpipes shall be either temporary or permanent in nature, and with or without a water supply, provided that such standpipes conform to the requirements of Section 905 of the *International Building Code* as to capacity, outlets and materials.

## SECTION 1507 AUTOMATIC SPRINKLER SYSTEM

### **[F] 1507.1 Completion before occupancy.**

In portions of a building where an automatic sprinkler system is required by this code, it shall be unlawful to occupy those portions of the building until the automatic sprinkler system installation has been tested and approved, except as provided in ~~North Carolina General Statutes 153A-363 and 160A-423.~~ N.C.G.S. 160D-1116.

### **[F] 1507.2 Operation of valves.**

Operation of sprinkler control valves shall be permitted only by properly authorized personnel and shall be accompanied by notification of duly designated parties. When the sprinkler protection is being regularly turned off and on to facilitate connection of newly completed segments, the sprinkler control valves shall be checked at the end of each work period to ascertain that protection is in service.

## SECTION 1508 ACCESSIBILITY

### **[BE] 1508.1 Construction sites.**

Structures, sites, and equipment directly associated with the actual process of construction, including but not limited to scaffolding, bridging, material hoists, material storage, or construction trailers are not required to be accessible.

## SECTION 1509 WATER SUPPLY FOR FIRE PROTECTION

### **[F] 1509.1 When required.**

An approved water supply for fire protection, either temporary or permanent, shall be made available as soon as combustible material arrives on the site: on commencement of vertical combustible construction, and on installation of a standpipe system in buildings under construction, in accordance with Sections 1509.1 through 1509.5.

**Exception:** The fire code official is authorized to reduce the fire-flow requirements for isolated buildings or a group of buildings in rural areas or small communities where the development of full fire-flow requirements is impractical.

**[F] 1509.2 Combustible building materials.** When combustible building materials of the building under construction are delivered to a site, a minimum fire flow of 500 gallons per minute (1893 L/m) shall be provided. The fire hydrant used to provide this fire flow supply shall be within 500 feet (152 m) of the combustible building materials as measured along an approved fire apparatus access lane. Where the site configuration is such that one fire hydrant cannot be located within 500 feet (152 m) of all combustible building materials, additional fire hydrants shall be required to provide coverage in accordance with this section.

**[F] 1509.3 Vertical construction of Types III, IV and V construction.** Prior to commencement of vertical construction of Type III, IV or V buildings that utilize any combustible building materials, the fire flow required by Sections 1509.3.1 through 1509.3.3 shall be provided, accompanied by fire hydrants in sufficient quantity to deliver the required fire flow and proper coverage.

**[F] 1509.3.1 Fire separation up to 30 feet.** Where a building of Type III, IV or V construction has a fire separation distance of less than 30 feet (9144 mm) from property lot lines, and an adjacent property has an existing structure or

otherwise can be built on, the water supply shall provide either a minimum of 500 gallons per minute (1893 L/m), or the entire fire flow required for the building when constructed, whichever is greater.

**[F] 1509.3.2 Fire separation of 30 feet up to 60 feet.** Where a building of Type III, IV or V construction has a fire separation distance of 30 feet (9144 mm) up to 60 feet (18 288 mm) from property lot lines, and an adjacent property has an *existing structure* or otherwise can be constructed upon, the water supply shall provide a minimum of 500 gallons per minute (1893 L/m), or 50 percent of the fire flow required for the building when constructed, whichever is greater.

**[F] 1509.3.3 Fire separation of 60 feet or greater.** Where a building of Type III, IV or V construction has a fire separation of 60 feet (18 288 mm) or greater from a property lot line, a water supply of 500 gallons per minute (1893 L/m) shall be provided.

**[F] 1509.4 Vertical construction, Types I and II construction.** If combustible construction materials are delivered to the construction site, water supply in accordance with Section 1509.2 shall be provided. Additional water supply for fire flow is not required prior to commencing vertical construction of Type I and II buildings.

**[F] 1509.5 Standpipe supply.** Regardless of the presence of combustible building materials, the construction type or the fire separation distance, where a standpipe is required in accordance with Section 1506, a water supply providing a minimum flow of 500 gallons per minute (1893 L/m) shall be provided. The fire hydrant used for this water supply shall be located within 100 feet (30 480 mm) of the fire department connection supplying the standpipe.

# CHAPTER 16

## REFERENCE STANDARDS

This chapter lists the standards that are referenced in various sections of this document. The standards are listed herein by the promulgating agency of the standard, the standard identification, the effective date and title, and the section or sections of this document that reference the standard. The application of the referenced standards shall be as specified in Section 102.4.

ACI  
American Concrete Institute  
38800 Country Club Drive  
Farmington Hills, MI 48331-3439

| Standard Reference No. | Title | Reference in Code Section |
|------------------------|-------|---------------------------|
|------------------------|-------|---------------------------|

|               |   |                |
|---------------|---|----------------|
| <u>562—21</u> | <u>Assessment, Repair, and Rehabilitation of Existing Concrete Structures—Code Requirements</u> | <u>405.1.1</u> |
|---------------|---|----------------|

ASCE/SEI  
 American Society of Civil Engineers  
 Structural Engineering Institute  
 1801 Alexander Bell Drive  
 RestonVA20191-4400

| Standard Reference No. | Title  | Reference in Code Section  |
|------------------------|--|--|
| 7—1988                 | <u>Minimum Design Loads and Associated Criteria for Buildings and Other Structure</u>      | <a href="#">503.12706.3.2</a>  |
| 7—1993                 | <u>Minimum Design Loads and Associated Criteria for Buildings and Other Structures</u>     | <a href="#">503.12706.3.2</a>  |
| 7—1995                 | <u>Minimum Design Loads and Associated Criteria for Buildings and Other Structures</u>     | <a href="#">503.12706.3.2</a>  |
| 7—1998                 | <u>Minimum Design Loads and Associated Criteria for Buildings and Other Structures</u>     | <a href="#">503.12706.3.2</a>  |
| 7—2002                 | <u>Minimum Design Loads and Associated Criteria for Buildings and Other Structures</u>     | <a href="#">503.12706.3.2</a>  |
| 7—2005                 | <u>Minimum Design Loads and Associated Criteria for Buildings and Other Structures</u>     | <a href="#">503.12706.3.2</a>  |
| 7—2010                 | <u>Minimum Design Loads and Associated Criteria for Buildings and Other Structures</u>     | <a href="#">503.12706.3.2</a>  |
| 7—2010 w/Supplement 1  | <del>Minimum Design Loads and Associated Criteria for Buildings and Other Structures</del> | <del>301.1.4.1, 403.4, 403.9, 807.5</del>  |
| 7—2016 w/Supplement 1  | <u>Minimum Design Loads and Associated Criteria for Buildings and Other Structures</u>     | <a href="#">503.12706.3.2</a>  |
| 7—2022                 | <u>Minimum Design Loads and Associated Criteria for Buildings and Other Structures</u>     | <a href="#">304.2304.3.1503.4503.12503.13706.3.2805.3805.4</a>   |
| 41—2013                | <u>Seismic Evaluation and Retrofit of Existing Buildings</u>                               | <del>301.1.4, 301.1.4.1, Table 301.1.4.1-301.1.4.2, Table 301.1.4.2, 402.4, Table 402.4, 403.4, 404.2.1, Table 404.2.1, 404.2.3, 407.4</del> |
| 41—2017                |  |  |
|                        |  | <a href="#">304.3.1Table, 304.3.1304.3.2Table 304.3.2503.5503.11506.5.3906.2906.31006.3</a>  |

ASHRAE  
180 Technology Parkway  
Peachtree Corners, GA 30092

| Standard Reference No. | Title   | Reference in Code Section    |
|------------------------|---|------------------------------|
| 62.1— <del>2013</del>  | Ventilation for Acceptable Indoor Air Quality | -809.2 <a href="#">807.2</a> |
| 62.1— <del>2022</del>  |   |                              |

ASME  
American Society of Mechanical Engineers  
Two Park Avenue  
New York NY 10017

| <u>Standard Reference No.</u>                   | <u>Title</u>  | <u>Reference in Code Section</u>  |
|---|---|---|
| <del>A17.1—</del><br><del>CSA B44—2013</del>    | Safety Code for Elevators and Escalators                    | 410.8.2, <del>806.1.2</del> , 902.1.2                                       |
| A17.1—<br><del>CSA B44—2022</del>               |   | <a href="#">306.7.7</a> , <a href="#">306.7.8</a> , <a href="#">902.1.2</a> |
| A17.3— <del>2008</del><br><del>A17.3—2023</del> | Safety Code for Existing Elevators and Escalators           | <a href="#">902.1.2</a>   |
| A18.1— <del>2008</del><br><del>A18.1—2022</del> | Safety Standard for Platform Lifts and Stairway Chair Lifts | 410.8.3 <a href="#">306.7.9</a>   |

ASTM  
 ASTM International  
 100 Barr Harbor Drive, P.O. Box C700  
 West Conshohocken PA19428-2959

| Standard Reference No. Title   | Reference in Code Section                         |
|--|---|
| <del>C94/C94M—13</del> Standard Specification for Ready-Mixed Concrete<br><del>C94/C94M—21b</del>  | <a href="#">109.3.1</a>                           |
| <del>E84—13A</del> <del>Test Method for Surface Burning Characteristics of Building Materials</del>  | 4205.9  |
| <del>E108—11</del> Standard Test Methods for Fire Tests of Roof Coverings<br><del>E108—20a</del>   | 4205.5 <a href="#">1204.5</a>                     |
| <del>E136—12</del><br><del>E136—22</del> Standard Test Method for Assessing Combustibility of Materials Using a Vertical Tube Furnace at 750 Degrees C                     | <a href="#">202</a>                               |
| <del>F2006—10</del><br><del>F2006—21</del> Standard Safety Specification for Window Fall Prevention Devices for Non-Emergency Escape (Egress) and Rescue (Ingress) Windows | 406.2 <a href="#">505.2,702.4</a>                 |
| <del>F2090—10</del><br><del>F2090—21</del> Specification for Window Fall Prevention Devices with Emergency (Egress) Release Mechanisms                                     | 406.2 <a href="#">505.2,505.3.1,702.4,702.5.1</a> |



IBC—~~24~~ International Building Code®

101.1, 101.4.1, 101.8, 202, 301.1, 301.1.4, 301.1.4.1, 301.1.4.2, 401.2.3, ~~402.1, 402.2, 402.3, 402.3.1, 402.4, 402.5, 403.1, 403.2, 403.3, 403.3.1, 403.4, 403.9, 403.10, 403.11, 404.2.1, 404.2.3, 404.3, 404.4, 404.5, 406.3, 407.1, 407.3, 407.4, 408.3, 410.4, 410.4.2, 410.6, 410.8.1, 410.8.4, 410.8.5, 410.8.6, 410.8.7, 410.8.8, 410.8.10, 410.9, 410.9.3, 410.9.4, 411.1.4, 411.1.11, 501.3, 601.3, 602.3, 602.4, 606.1, 606.2.2.1, 606.2.2.3, 606.2.3, 606.2.4, 701.2, 701.3, 702.1, 702.2, 702.3, 702.4, 702.5, 702.6, 706.1, 706.3, 706.3.2, 707.2, 801.3, 802.1, 803.2.1, 803.2.3, 805.3, 805.3.1.2.1, 803.3, 803.4, 803.5.2, 803.6, 804.1.1, 804.2.2, 805.1, 805.2, 805.3, 805.3.1.2.1, 805.4.1.1, 805.4.3, 805.5, 805.6, 805.7.1, 805.8.1, 805.9.2, 805.10.1.1, 805.10.1.2, 805.10.1.3, 805.10.2, 805.11.2, 806.3, 806.4, 806.5, 807.2, 807.4, 807.5, 807.6, 901.2.1, 901.2.2, 901.3, 901.3.1, 901.3.2, 901.3.3, 901.3.4, 901.3.5, 901.3.6, 901.3.7, 901.3.8, 901.3.9, 901.3.10, 901.3.11, 901.3.12, 901.3.13, 901.3.14, 901.3.15, 901.3.16, 901.3.17, 901.3.18, 901.3.19, 901.3.20, 901.3.21, 901.3.22, 901.3.23, 901.3.24, 901.3.25, 901.3.26, 901.3.27, 901.3.28, 901.3.29, 901.3.30, 901.3.31, 901.3.32, 901.3.33, 901.3.34, 901.3.35, 901.3.36, 901.3.37, 901.3.38, 901.3.39, 901.3.40, 901.3.41, 901.3.42, 901.3.43, 901.3.44, 901.3.45, 901.3.46, 901.3.47, 901.3.48, 901.3.49, 901.3.50, 901.3.51, 901.3.52, 901.3.53, 901.3.54, 901.3.55, 901.3.56, 901.3.57, 901.3.58, 901.3.59, 901.3.60, 901.3.61, 901.3.62, 901.3.63, 901.3.64, 901.3.65, 901.3.66, 901.3.67, 901.3.68, 901.3.69, 901.3.70, 901.3.71, 901.3.72, 901.3.73, 901.3.74, 901.3.75, 901.3.76, 901.3.77, 901.3.78, 901.3.79, 901.3.80, 901.3.81, 901.3.82, 901.3.83, 901.3.84, 901.3.85, 901.3.86, 901.3.87, 901.3.88, 901.3.89, 901.3.90, 901.3.91, 901.3.92, 901.3.93, 901.3.94, 901.3.95, 901.3.96, 901.3.97, 901.3.98, 901.3.99, 901.4, 901.5, 901.6, 901.7, 901.8, 901.9, 901.10, 901.11, 901.12, 901.13, 901.14, 901.15, 901.16, 901.17, 901.18, 901.19, 901.20, 901.21, 901.22, 901.23, 901.24, 901.25, 901.26, 901.27, 901.28, 901.29, 901.30, 901.31, 901.32, 901.33, 901.34, 901.35, 901.36, 901.37, 901.38, 901.39, 901.40, 901.41, 901.42, 901.43, 901.44, 901.45, 901.46, 901.47, 901.48, 901.49, 901.50, 901.51, 901.52, 901.53, 901.54, 901.55, 901.56, 901.57, 901.58, 901.59, 901.60, 901.61, 901.62, 901.63, 901.64, 901.65, 901.66, 901.67, 901.68, 901.69, 901.70, 901.71, 901.72, 901.73, 901.74, 901.75, 901.76, 901.77, 901.78, 901.79, 901.80, 901.81, 901.82, 901.83, 901.84, 901.85, 901.86, 901.87, 901.88, 901.89, 901.90, 901.91, 901.92, 901.93, 901.94, 901.95, 901.96, 901.97, 901.98, 901.99, 1001.3, 1002.1, 1002.2, 1007.1, 1007.2, 1007.3.1, 1011.1, 1012.1, 1012.2, 1012.3, 1012.4.1, 1012.4.2, 1012.4.3, 1012.4.4, 1012.5.1, 1012.5.1.1, 1012.5.3, 1012.6.1, 1012.6.3, 1012.7.1, 1012.7.2, 1012.7.3, 1012.8, 1012.8.3, 1012.8.4, 1012.8.5, 1012.8.6, 1012.8.7, 1012.8.8, 1012.8.9, 1012.8.10, 1012.8.11, 1012.8.12, 1012.8.13, 1012.8.14, 1012.8.15, 1012.8.16, 1012.8.17, 1012.8.18, 1012.8.19, 1012.8.20, 1012.8.21, 1012.8.22, 1012.8.23, 1012.8.24, 1012.8.25, 1012.8.26, 1012.8.27, 1012.8.28, 1012.8.29, 1012.8.30, 1012.8.31, 1012.8.32, 1012.8.33, 1012.8.34, 1012.8.35, 1012.8.36, 1012.8.37, 1012.8.38, 1012.8.39, 1012.8.40, 1012.8.41, 1012.8.42, 1012.8.43, 1012.8.44, 1012.8.45, 1012.8.46, 1012.8.47, 1012.8.48, 1012.8.49, 1012.8.50, 1012.8.51, 1012.8.52, 1012.8.53, 1012.8.54, 1012.8.55, 1012.8.56, 1012.8.57, 1012.8.58, 1012.8.59, 1012.8.60, 1012.8.61, 1012.8.62, 1012.8.63, 1012.8.64, 1012.8.65, 1012.8.66, 1012.8.67, 1012.8.68, 1012.8.69, 1012.8.70, 1012.8.71, 1012.8.72, 1012.8.73, 1012.8.74, 1012.8.75, 1012.8.76, 1012.8.77, 1012.8.78, 1012.8.79, 1012.8.80, 1012.8.81, 1012.8.82, 1012.8.83, 1012.8.84, 1012.8.85, 1012.8.86, 1012.8.87, 1012.8.88, 1012.8.89, 1012.8.90, 1012.8.91, 1012.8.92, 1012.8.93, 1012.8.94, 1012.8.95, 1012.8.96, 1012.8.97, 1012.8.98, 1012.8.99, 1013.1, 1013.2, 1013.3, 1013.4, 1013.5, 1013.6, 1013.7, 1013.8, 1013.9, 1013.10, 1013.11, 1013.12, 1013.13, 1013.14, 1013.15, 1013.16, 1013.17, 1013.18, 1013.19, 1013.20, 1013.21, 1013.22, 1013.23, 1013.24, 1013.25, 1013.26, 1013.27, 1013.28, 1013.29, 1013.30, 1013.31, 1013.32, 1013.33, 1013.34, 1013.35, 1013.36, 1013.37, 1013.38, 1013.39, 1013.40, 1013.41, 1013.42, 1013.43, 1013.44, 1013.45, 1013.46, 1013.47, 1013.48, 1013.49, 1013.50, 1013.51, 1013.52, 1013.53, 1013.54, 1013.55, 1013.56, 1013.57, 1013.58, 1013.59, 1013.60, 1013.61, 1013.62, 1013.63, 1013.64, 1013.65, 1013.66, 1013.67, 1013.68, 1013.69, 1013.70, 1013.71, 1013.72, 1013.73, 1013.74, 1013.75, 1013.76, 1013.77, 1013.78, 1013.79, 1013.80, 1013.81, 1013.82, 1013.83, 1013.84, 1013.85, 1013.86, 1013.87, 1013.88, 1013.89, 1013.90, 1013.91, 1013.92, 1013.93, 1013.94, 1013.95, 1013.96, 1013.97, 1013.98, 1013.99, 1101.1, 1101.2, 1101.3, 1101.4, 1101.5, 1101.6, 1101.7, 1101.8, 1101.9, 1101.10, 1101.11, 1101.12, 1101.13, 1101.14, 1101.15, 1101.16, 1101.17, 1101.18, 1101.19, 1101.20, 1101.21, 1101.22, 1101.23, 1101.24, 1101.25, 1101.26, 1101.27, 1101.28, 1101.29, 1101.30, 1101.31, 1101.32, 1101.33, 1101.34, 1101.35, 1101.36, 1101.37, 1101.38, 1101.39, 1101.40, 1101.41, 1101.42, 1101.43, 1101.44, 1101.45, 1101.46, 1101.47, 1101.48, 1101.49, 1101.50, 1101.51, 1101.52, 1101.53, 1101.54, 1101.55, 1101.56, 1101.57, 1101.58, 1101.59, 1101.60, 1101.61, 1101.62, 1101.63, 1101.64, 1101.65, 1101.66, 1101.67, 1101.68, 1101.69, 1101.70, 1101.71, 1101.72, 1101.73, 1101.74, 1101.75, 1101.76, 1101.77, 1101.78, 1101.79, 1101.80, 1101.81, 1101.82, 1101.83, 1101.84, 1101.85, 1101.86, 1101.87, 1101.88, 1101.89, 1101.90, 1101.91, 1101.92, 1101.93, 1101.94, 1101.95, 1101.96, 1101.97, 1101.98, 1101.99, 1201.1, 1201.2, 1201.3, 1201.4, 1201.5, 1201.6, 1201.7, 1201.8, 1201.9, 1201.10, 1201.11, 1201.12, 1201.13, 1201.14, 1201.15, 1201.16, 1201.17, 1201.18, 1201.19, 1201.20, 1201.21, 1201.22, 1201.23, 1201.24, 1201.25, 1201.26, 1201.27, 1201.28, 1201.29, 1201.30, 1201.31, 1201.32, 1201.33, 1201.34, 1201.35, 1201.36, 1201.37, 1201.38, 1201.39, 1201.40, 1201.41, 1201.42, 1201.43, 1201.44, 1201.45, 1201.46, 1201.47, 1201.48, 1201.49, 1201.50, 1201.51, 1201.52, 1201.53, 1201.54, 1201.55, 1201.56, 1201.57, 1201.58, 1201.59, 1201.60, 1201.61, 1201.62, 1201.63, 1201.64, 1201.65, 1201.66, 1201.67, 1201.68, 1201.69, 1201.70, 1201.71, 1201.72, 1201.73, 1201.74, 1201.75, 1201.76, 1201.77, 1201.78, 1201.79, 1201.80, 1201.81, 1201.82, 1201.83, 1201.84, 1201.85, 1201.86, 1201.87, 1201.88, 1201.89, 1201.90, 1201.91, 1201.92, 1201.93, 1201.94, 1201.95, 1201.96, 1201.97, 1201.98, 1201.99, 1301.2, 1302.1, 1302.2, 1302.2.1, 1302.3, 1302.4, 1302.5, 1302.6, 1401.2.2, 1401.2.3, 1401.2.4, 1401.3.3, 1401.4.1, 1401.6.1, 1401.6.1.1, 1401.6.2, 1401.6.2.1, 1401.6.3.1, 1401.6.3.2, 1401.6.4.1, 1401.6.5, 1401.6.5.1, 1401.6.6, 1401.6.7.1, 1401.6.8, 1401.6.9, 1401.6.9.1, 1401.6.10, 1401.6.10.1, 1401.6.11, 1401.6.11.1, 1401.6.12.1, 1401.6.13, 1401.6.15.1, 1401.6.16.1, 1401.6.17, 1401.6.17.1, 1401.6.18, 1401.6.18.1, 1401.6.19, Table 1401.6.19, 1501.5, 1501.6.1, 1501.6.4.1, 1501.6.7, 1506.1, 1506.3~~

[101.4.1104.3.1106.2.2109.3.3109.3.6109.3.9109.3.10110.2202301.3302.4.130.2.5303.1303.3304.1304.3.1304.3.2305.1306.5306.6.1306.6.1.1306.7306.7.2306.7.4306.7.5306.7.7306.7.10306.7.11306.7.11.1306.7.11.2306.7.11.3306.7.12306.7.13306.7.15306.7.17306.7.18306.7.18.3306.7.18.4306.7.18.5306.7.18.7309.2309.2.1401.3402.1405.2.1.1405.2.3.1405.2.3.3405.2.4405.2.5405.2.6501.2502.1502.1.2502.2502.3502.4502.5503.1503.2503.3503.4503.5503.11503.12503.13503.14503.15503.16503.17503.19503.2050.5.3505.4506.1506.3506.4506.5.1506.5.2506.5.3506.5.4507.3701.2701.3702.1702.2702.3702.5702.6702.7704.1.1704.3705.1705.2706.2706.3.2802.2.1802.2.3802.3802.4802.5.2802.6802.6803.1.1803.2803.2.2803.2.3803.2.4803.2.5803.2.6803.3804.1804.4804.5.1804.5.1.1](#)

[Table804.5.1.1\(1\)804.5.1.2.1804.6.1.2804.6.3804.6.4804.6.5804.7804.7.3804.8804.9.1804.10804.10.1804.10.1804.11804.13.2804.14.2805.2805.3805.4904.1.2904.1.3904.1.4904.1.6904.1.7904.1.8904.2904.2.1904.2.2905.2905.3905.4906.2906.3906.61001.21001.31002.11002.21002.31002.41004.11006.11006.21006.31006.41010.11011.11011.2.11011.2.21011.31011.5.11011.5.21011.5.31011.5.61011.6.11011.6.11011.6.11011.7.11011.7.21011.7.31011.8.11011.8.21011.8.31101.21101.31101.51101.71102.11102.21102.31103.11103.21103.31201.41202.21203.121204.21204.91206.11302.1.21302.1.31302.1.41303.1.31304.1.11305.2.11305.2.1.11305.2.21305.2.2.11305.2.3.21305.2.3.31305.2.4.11305.2.51305.2.5.11305.2.61305.2.7.11305.2.81305.2.91305.2.9.11305.2.101305.2.10.11305.2.111305.2.11.11305.2.12.11305.2.13Table 1305.2.151305.2.15.11305.2.16.11305.2.171305.2.17.11305.2.181305.2.18.11305.2.19Table 1305.2.191305.2.201305.2.20.11307.1.11401.21402.11402.2.11402.31402.41402.51402.61501.51504.1.11504.1.4.11504.1.71509.11509.31510.1](#)

ICC continued

Standard Reference No. Title

Reference in Code Section

~~ICC A117.1 2009~~  
~~ICC A117.1 2017~~

Accessible and Usable Buildings and Facilities

~~410.8.2, 410.8.3, 410.8.10, 806.1.2, 806.1.3, 806.1.9,~~  
~~306.3306.7306.7.11306.7.12306.7.13502.6503.181011.41101.6~~

~~ICC/~~  
~~NSSA 500 2020 ICC/NSSA Standard for the Design and Construction of Storm Shelters~~

~~303.1.1303.2~~

~~ICCPC-24~~ ICC Performance Code®

~~104.2.3~~

~~IECC-15~~  
~~IECC-24~~

International Energy Conservation Code®

~~301.2, 702.6, 708.1, 811.1, 908.4~~  
~~302.2702.7708.1809.1907.11104.1~~

~~IFC-15~~  
~~IFC-24~~

International Fire Code®

~~401.1.4.2, 301.1.1, 301.2, 411.1.3, 411.1.5, 803.2.1, 803.2.3, 1012.5.1.1, 1301.2, 1401.3.2,~~  
~~1401.6.8.1, 1401.6.14, 1401.6.14.1, 1501.5, 1504.1, 1504.2~~

~~101.2.2101.4.2301.3.1302.2307.1308.1802.2.1802.2.3803.2.3803.4.1.1803.4.1.2803.4.1.3803.4.1.4803.4~~  
~~.1.5803.4.6Table804.5.1.1(1)904.1.51011.6.1.11303.1.21305.2.8.11305.2.141305.2.14.11401.21501.115~~  
~~01.51502.11502.1.11502.21502.31504.11507.11507.2~~

~~IFGC-15~~

~~IFGC-24~~

International Fuel Gas Code®

~~301.2, 702.6,~~ ~~302.2702.7.1~~

~~IMC-15~~  
~~IMC-24~~

International Mechanical Code®

~~301.2, 702.6, 809.1, 902.1.1, 902.2.1, 1009.1,~~  
~~1401.6.7.1, 1401.6.8, 1401.6.8.1302.2702.7807.1902.1.11008.11305.2.7.11305.2.81305.2.8.1~~

~~IPC-15~~  
~~IPC-24~~

International Plumbing Code®

~~301.2, 609.1, 702.6, 810.1, 1010.1, 1010.2, 1010.3, 1010.5,~~  
~~1501.7302.2408.1702.71009.11009.21009.31009.51302.1.61503.1~~

~~IPMC-24~~

International Property Maintenance Code®

~~101.4.2302.21303.1.21401.2~~

~~IRC-15~~  
~~IRC-24~~

International Residential Code®

~~101.4.1, 301.2, 402.2, 402.5, 402.6, 402.7, 402.8, 402.9, 403.2, 403.3, 403.4, 403.5, 403.6, 403.7, 403.8, 403.9, 404.2, 404.3.1, 404.5, 408.3,~~  
~~602.3, 602.4, 701.3, 702.5, 706.2, 707.2, 707.4, 707.5, 708.1, 8.0.11, 804.4.2.2, 804.4.2.3, 804.4.2.4, 807.4, 808.3,~~  
~~811.1, 907.4, 908.1, 1001.1, 1001.2, 1001.3, 1001.4, 1001.5, 1001.6, 1001.7, 1001.8, 1001.9, 1001.10, 1001.11, 1001.12, 1001.13, 1001.14, 1001.15,~~  
~~1301.2, 1302.1, 1302.2, 1302.2.1, 1302.3, 1302.4, 1302.6, 1302.5, 1401.2.2, 1401.2.3, 1401.3.3~~  
~~101.2101.4.1104.3.1109.3.1109.3.10302.2307.1308.1401.3402.1405.2.6502.2502.3502.4503.2503.3503.1~~  
~~1505.2505.3507.3701.3702.4702.5706.2708.1805.2806.4809.1906.2907.11011.2.11103.11103.21103.311~~  
~~04.11201.41302.1.21302.1.31302.1.31303.1.31401.21402.11402.21402.2.11402.31402.41402.51402.6~~

NFPA  
 National Fire Protection Association  
 1 Batterymarch Park  
 Quincy MA 02169-7471

| Standard Reference No. Title  | Reference in Code Section  |
|---|--|
| <del>NFPA 13R-13</del> Standard for the Installation of Sprinkler Systems in Residential Occupancies up to and Including Four Stories in Height | <del>804.2.5, 1012.2.1.3</del>   |
| <del>NFPA 70-14</del><br>NFPA 70-23 National Electrical Code  | <del>301.2, 607.1.1, 607.1.2, 607.1.3, 607.1.4, 607.1.5, 808.1, 808.3.4, 808.3.7, 1008.1, 1008.2, 1008.3, 1008.4</del><br><a href="#">302.2, 406.1, 406.1.1, 406.1.2, 406.1.3, 406.1.4, 406.1.5, 406.1.6, 406.1.7, 406.1.8, 406.1.9, 406.1.10, 406.1.11, 406.1.12, 406.1.13, 406.1.14, 406.1.15, 406.1.16, 406.1.17, 406.1.18, 406.1.19, 406.1.20, 406.1.21, 406.1.22, 406.1.23, 406.1.24, 406.1.25, 406.1.26, 406.1.27, 406.1.28, 406.1.29, 406.1.30, 406.1.31, 406.1.32, 406.1.33, 406.1.34, 406.1.35, 406.1.36, 406.1.37, 406.1.38, 406.1.39, 406.1.40, 406.1.41, 406.1.42, 406.1.43, 406.1.44, 406.1.45, 406.1.46, 406.1.47, 406.1.48, 406.1.49, 406.1.50, 406.1.51, 406.1.52, 406.1.53, 406.1.54, 406.1.55, 406.1.56, 406.1.57, 406.1.58, 406.1.59, 406.1.60, 406.1.61, 406.1.62, 406.1.63, 406.1.64, 406.1.65, 406.1.66, 406.1.67, 406.1.68, 406.1.69, 406.1.70, 406.1.71, 406.1.72, 406.1.73, 406.1.74, 406.1.75, 406.1.76, 406.1.77, 406.1.78, 406.1.79, 406.1.80, 406.1.81, 406.1.82, 406.1.83, 406.1.84, 406.1.85, 406.1.86, 406.1.87, 406.1.88, 406.1.89, 406.1.90, 406.1.91, 406.1.92, 406.1.93, 406.1.94, 406.1.95, 406.1.96, 406.1.97, 406.1.98, 406.1.99, 406.1.100</a> |
| <del>NFPA 72-13</del><br><u>NFPA 72-22</u> National Fire Alarm and Signaling Code   | <del>402.5, 403.10, 804.4</del> <a href="#">803.4.3</a>  |
| <del>NFPA 99-15</del><br><u>NFPA 99-24</u> Health Care Facilities Code  | <del>607.1.4</del> <a href="#">302.2, 1406.1, 1406.1.1, 1406.1.2, 1406.1.3, 1406.1.4, 1406.1.5, 1406.1.6, 1406.1.7, 1406.1.8, 1406.1.9, 1406.1.10, 1406.1.11, 1406.1.12, 1406.1.13, 1406.1.14, 1406.1.15, 1406.1.16, 1406.1.17, 1406.1.18, 1406.1.19, 1406.1.20, 1406.1.21, 1406.1.22, 1406.1.23, 1406.1.24, 1406.1.25, 1406.1.26, 1406.1.27, 1406.1.28, 1406.1.29, 1406.1.30, 1406.1.31, 1406.1.32, 1406.1.33, 1406.1.34, 1406.1.35, 1406.1.36, 1406.1.37, 1406.1.38, 1406.1.39, 1406.1.40, 1406.1.41, 1406.1.42, 1406.1.43, 1406.1.44, 1406.1.45, 1406.1.46, 1406.1.47, 1406.1.48, 1406.1.49, 1406.1.50, 1406.1.51, 1406.1.52, 1406.1.53, 1406.1.54, 1406.1.55, 1406.1.56, 1406.1.57, 1406.1.58, 1406.1.59, 1406.1.60, 1406.1.61, 1406.1.62, 1406.1.63, 1406.1.64, 1406.1.65, 1406.1.66, 1406.1.67, 1406.1.68, 1406.1.69, 1406.1.70, 1406.1.71, 1406.1.72, 1406.1.73, 1406.1.74, 1406.1.75, 1406.1.76, 1406.1.77, 1406.1.78, 1406.1.79, 1406.1.80, 1406.1.81, 1406.1.82, 1406.1.83, 1406.1.84, 1406.1.85, 1406.1.86, 1406.1.87, 1406.1.88, 1406.1.89, 1406.1.90, 1406.1.91, 1406.1.92, 1406.1.93, 1406.1.94, 1406.1.95, 1406.1.96, 1406.1.97, 1406.1.98, 1406.1.99, 1406.1.100</a>   |
| <del>NFPA 101-15</del>  |  |
| NFPA 101-24 Life Safety Code  | <del>805.2</del> <a href="#">804.2</a>   |

UL  
UL LLC  
333 Pfingsten Road  
Northbrook IL 60062

| Standard Reference No. | Title  | Reference in Code Section     |
|------------------------|--|-------------------------------|
| <del>723-08</del>      | <del>Standard for Test for Surface Burning Characteristics of Building Materials with Revisions Through September 2010</del> | 1205.9                        |
| 790—04                 | Standard Test Methods for Fire Tests of Roof Coverings—with Revisions through October <del>2008-2018</del>                   | 1205.5 <a href="#">1204.5</a> |

# Appendix A: GUIDELINES FOR THE SEISMIC RETROFIT OF EXISTING BUILDINGS

The provisions contained in this appendix are not mandatory unless specifically referenced in the adopting ordinance.

## CHAPTER A1

# SEISMIC STRENGTHENING PROVISIONS FOR UNREINFORCED MASONRY BEARING WALL BUILDINGS

### SECTION A101 PURPOSE

**[BS] A101.1 Purpose.** The purpose of this chapter is to promote public safety and welfare by reducing the risk of death or injury from the effects of earthquakes on existing unreinforced masonry bearing wall buildings.

The provisions of this chapter are intended as minimum standards for structural seismic resistance, and are established primarily to reduce the risk of life loss or injury. Compliance with these provisions will not necessarily prevent loss of life or injury, or prevent earthquake damage to rehabilitated retrofitted buildings.

### SECTION A102 SCOPE

**[BS] A102.1 General.** The provisions of this chapter shall apply to all *existing buildings* having ~~at least one unreinforced masonry bearing wall~~ not more than six stories in height above the base of the structure and having not fewer than one unreinforced masonry bearing wall. The elements regulated by this chapter shall be determined in accordance with Table ~~A1-A~~ A102.1. Except as provided herein, other structural provisions of the building code shall apply. This chapter does not apply to the *alteration* of existing electrical, plumbing, mechanical or fire safety systems.

#### NOTE to RCC

Table A102.1 is formerly Table A1-A

**[BS] TABLE A102.1  
ELEMENTS REGULATED BY THIS CHAPTER**

| BUILDING ELEMENTS                               | $S_{D1}$               |                       |                      |              |
|---|------------------------|-----------------------|----------------------|--------------|
|   | $\geq 0.067g < 0.133g$ | $\geq 0.133g < 0.20g$ | $\geq 0.20g < 0.30g$ | $\geq 0.30g$ |
| Parapets  | X                      | X                     | X                    | X            |
| Walls, anchorage                                | X                      | X                     | X                    | X            |
| Walls, $h/t$ ratios                             |                        | X                     | X                    | X            |
| Walls, in-plane shear                           |                        | X                     | X                    | X            |
| Diaphragms <sup>a</sup>                         |                        |                       | X                    | X            |
| Diaphragms, shear transfer <sup>b</sup>         |                        | X                     | X                    | X            |
| Diaphragms, demand-capacity ratios <sup>b</sup> |                        |                       | X                    | X            |

a. Applies only to buildings designed according to the general procedures of Section A110.

b. Applies only to buildings designed according to the special procedures of Section A111.

[BS] **A102.2 Essential and hazardous facilities.** The provisions of this chapter shall not apply to the strengthening of buildings in *Risk Category* III or IV. Such buildings shall be strengthened to meet the requirements of the *International Building Code* for new buildings of the same *risk category* or other such criteria *approved by the code official*.

## SECTION A103 DEFINITIONS

[BS] **A103.1 Definitions.** For the purpose of this chapter, the applicable definitions in the building code shall also apply.

[BS] **BED JOINT.** The horizontal layer of mortar on which a masonry unit is laid.

[BS] **COLLAR JOINT.** The vertical space between adjacent wythes. A collar joint may contain mortar or grout.

[BS] **CROSSWALL.** A new or existing wall that meets the requirements of Section A111.3. A crosswall is not a shear wall.

[BS] **CROSSWALL SHEAR CAPACITY.** The unit shear value times the length of the crosswall,  $v_c L_c$ .

[BS] **DETAILED BUILDING SYSTEM ELEMENTS.** The localized elements and the interconnections of these elements that define the design of the building.

[BS] **DIAPHRAGM EDGE.** The intersection of the horizontal diaphragm and a shear wall.

[BS] **DIAPHRAGM SHEAR CAPACITY.** The unit shear value times the depth of the diaphragm,  $v_u D$ .

[BS] **FLEXIBLE DIAPHRAGM.** A diaphragm of wood or untopped metal deck construction in which the horizontal deformation along its length is at least two times the average story drift.

**HEAD JOINT.** The vertical mortar joint placed between masonry units within the wythe.

[BS] **NORMAL WALL.** A wall perpendicular to the direction of seismic forces.

[BS] **OPEN FRONT.** An exterior building wall line on one side only without vertical elements of the seismic force-resisting system in one or more stories.

[BS] **POINTING.** The process of removal of deteriorated mortar from between masonry units and placement of new mortar. Also known as repointing or tuckpointing for purposes of this chapter.

[BS] **REPOINTING.** See “*Pointing*.”

[BS] **RIGID DIAPHRAGM.** A diaphragm of concrete construction or concrete-filled metal deck construction.

[BS] **TUCKPOINTING.** See “*Pointing*.”

[BS] **UNREINFORCED MASONRY (URM).** Includes burned clay, concrete or sand-lime brick; hollow clay or concrete block; plain concrete; and hollow clay tile. These materials shall comply with the requirements of Section A106 as applicable.

[BS] **UNREINFORCED MASONRY BEARING WALL.** A URM wall that provides the vertical support for the reaction of floor or roof-framing members for which the total superimposed vertical load exceeds 100 pounds per linear foot (1459 N/m) of wall length.

[BS] **UNREINFORCED MASONRY (URM) WALL.** A masonry wall that relies on the tensile strength of masonry units, mortar and grout in resisting design loads, and in which the area of reinforcement is less than ~~25 percent~~ of the minimum amounts as defined for reinforced masonry walls.

[BS] **YIELD STORY DRIFT.** The lateral displacement of one level relative to the level above or below at which yield stress is first developed in a frame member.

## SECTION A104 SYMBOLS AND NOTATIONS

[BS] **A104.1 Symbols and notations.** For the purpose of this chapter, the following notations supplement the applicable symbols and notations in the building code.

$a_n$  = Diameter of core multiplied by its length or the area of the side of a square prism.

$A$  = Cross-sectional area of unreinforced masonry pier or wall, square inches ( $10^{-6}$  m<sup>2</sup>).

$A_b$  = Total area of the bed joints above and below the test specimen for each in-place shear test, square inches ( $10^{-6}$  m<sup>2</sup>).

$A_n$  = Area of net mortared or grouted section of a wall or wall pier.

$D$  = In-plane width dimension of pier, inches ( $10^{-3}$  m), or depth of diaphragm, feet (m).

$DCR$  = Demand-capacity ratio specified in Section A111.4.2.

$f'_m$  = ~~Compressive strength of masonry.~~ Lower bound masonry compressive strength.

$f_{sp}$  = Tensile-splitting strength of masonry.

- $F_{wx}$  = Force applied to a wall at level  $x$ , pounds (N).
- $H$  = Least clear height of opening on either side of a pier, inches ( $10^{-3}$  m).
- $h/t$  = Height-to-thickness ratio of URM wall. Height,  $h$ , is measured between wall anchorage levels and/or slab-on-grade.
- $L$  = Span of diaphragm between shear walls, or span between shear wall and open front, feet (m).
- $L_c$  = Length of crosswall, feet (m).
- $L_i$  = Effective diaphragm span for an open-front building specified in Section A111.8, feet (m).
- $P$  = Applied force as determined by standard test method of ASTM C496 or ASTM E519, pounds (N).
- $P_D$  = Superimposed dead load at the location under consideration, pounds (N). For determination of the rocking shear capacity, dead load at the top of the pier under consideration shall be used.
- $P_{D+L}$  = ~~Press~~ Stress resulting from the dead plus actual live load in place at the time of testing, pounds per square inch (kPa).
- $P_{test}$  = Splitting tensile test load determined by standard test method ASTM C496, pounds (N).
- $P_w$  = Weight of wall, pounds (N).
- $R$  = Response modification factor for Ordinary plain masonry shear walls in Bearing Wall System from Table 12.2-1 of ASCE 7, where  $R = 1.5$ .
- $S_{DS}$  = Design spectral acceleration at short period, in g units.
- $S_{D1}$  = Design spectral acceleration at 1-second period, in g units.
- $v_a$  = The shear strength of any URM pier,  $v_m A / 1.5$  pounds (N).
- $v_c$  = Unit shear strength for a crosswall sheathed with any of the materials given in Table A108.1(1) or Table A108.1(2), pounds per foot (N/m).
- $v_{mL}$  = Shear strength of unreinforced masonry, pounds per square inch (kPa).
- $V_{aa}$  = The shear strength of any URM pier or wall, pounds (N).
- $V_{ca}$  = Total shear capacity of crosswalls in the direction of analysis immediately above the diaphragm level being investigated,  $v_c L_c$ , pounds (N).
- $V_{cb}$  = Total shear capacity of crosswalls in the direction of analysis immediately below the diaphragm level being investigated,  $v_c L_c$ , pounds (N).
- $V_p$  = Shear force assigned to a pier on the basis of its relative shear rigidity, pounds (N).
- $V_r$  = Pier rocking shear capacity of any URM wall or wall pier, pounds (N).
- $v_{test}$  = Load at incipient cracking for each in-place shear test performed in accordance with Section A106.2.3.6, pounds (N).
- $v_{tl}$  = Lower bound mortar shear strength, pounds per square inch (kPa).
- $v_{to}$  = Mortar shear test values as specified in Section A106.2.3.6, pounds per square inch (kPa).
- $v_u$  = Unit shear capacity value for a diaphragm sheathed with any of the materials given in Table A108.1(1) or A108.1(2), pounds per foot (N/m).
- $V_{wx}$  = Total shear force resisted by a shear wall at the level under consideration, pounds (N).
- $W$  = Total seismic dead load as defined in the building code, pounds (N).
- $W_d$  = Total dead load tributary to a diaphragm level, pounds (N).
- $W_w$  = Total dead load of a URM wall above the level under consideration or above an open-front building, pounds (N).
- $W_{wx}$  = Dead load of a URM wall assigned to level  $x$  halfway above and below the level under consideration, pounds (N).
- $\Sigma v_u D$  = Sum of diaphragm shear capacities of both ends of the diaphragm, pounds (N).
- $\Sigma \Sigma v_u D$  = For diaphragms coupled with crosswalls,  $v_u D$  includes the sum of shear capacities of both ends of diaphragms coupled at and above the level under consideration, pounds (N).
- $\Sigma W_d$  = Total dead load of all the diaphragms at and above the level under consideration, pounds (N).

## SECTION A105 GENERAL REQUIREMENTS

**[BS] A105.1 General.** The seismic force-resisting system specified in this chapter shall comply with the *International Building Code* and referenced standards, except as modified herein.

**[BS] A105.2 Alterations and repairs.** *Alterations* and *repairs* required to meet the provisions of this chapter shall comply with applicable structural requirements of the building code unless specifically provided for in this chapter.

**[BS] A105.3 Requirements for plans.** The following construction information shall be included in the plans required by this chapter:

1. Dimensioned floor and roof plans showing existing walls and the size and spacing of floor and roof-framing members and sheathing materials. The plans shall indicate all existing URM walls, and new crosswalls and shear walls, and their materials of construction. The location of these walls and their openings shall be fully dimensioned and drawn to scale on the plans.
2. Dimensioned URM wall elevations showing openings, piers, wall classes as defined in Section A106.2.3.9, thickness, heights, wall shear test locations, cracks or damaged portions requiring *repairs*, the general condition of the mortar joints, and if and where pointing is required. Where the exterior face is veneer, the type of veneer, its thickness and its bonding and/or ties to the structural wall masonry shall be noted.
3. The type of interior wall and ceiling materials, and framing.
4. The extent and type of existing wall anchorage to floors and roof where used in the design.
5. The extent and type of parapet corrections that were previously performed, if any.
6. *Repair* details, if any, of cracked or damaged unreinforced masonry walls required to resist forces specified in this chapter.
7. All other plans, sections and details necessary to delineate required retrofit construction.
8. The design procedure used shall be stated on both the plans and the permit application.
9. Details of the anchor prequalification program required by Section A107.5.3, if used, including location and results of all tests.
10. Quality assurance requirements of special inspection for all new construction materials and for retrofit construction including: anchor tests, pointing or repointing of mortar joints, installation of adhesive or mechanical anchors, and other elements as deemed necessary to ensure compliance with this chapter.

**[BS] A105.4 Structural observation, testing and inspection.** Structural observation, in accordance with Section 4708 1704.6 of the *International Building Code*, shall be required for all structures in which seismic retrofit is being performed in accordance with this chapter. Structural observation shall include visual observation of work for compliance with the *approved* construction documents and confirmation of existing conditions assumed during design.

Structural testing and inspection for new and existing construction materials shall be in accordance with the building code, except as modified by this chapter.

Special inspection as described in Section A105.3, Item 10, shall be provided equivalent to Level 3 as prescribed in TMS 402, Table 3.1(2).

## SECTION A106 MATERIALS REQUIREMENTS

~~**[BS] A106.1 General.** Materials permitted by this chapter, including their appropriate strength design values and those existing configurations of materials specified herein, may be used to meet the requirements of this chapter.~~

**Condition of existing materials.** Existing materials used as part of the required vertical load-carrying or seismic force-resisting system shall be evaluated by on-site investigation and: determined to be in good condition (free of degraded mortar, degraded masonry units or significant cracking); or shall be repaired, enhanced, retrofitted or removed and replaced with new materials. Mortar joint deterioration shall be patched by pointing or repointing of the eroded joint in accordance with Section A106.2.3.10. Existing significant cracks in solid unit unreinforced and solid grouted hollow unit masonry shall be repaired.

~~**[BS] A106.2 Existing materials.** Existing materials used as part of the required vertical load-carrying or lateral force-resisting system shall be in sound condition, or shall be repaired or removed and replaced with new materials. All~~

~~other unreinforced masonry materials shall comply with the following requirements:~~

- ~~1. The lay-up of the masonry units shall comply with Section A106.3.2, and the quality of bond between the units has been verified to the satisfaction of the building official;~~
- ~~2. Concrete masonry units are verified to be load bearing units complying with ASTM C90 or such other standard as is acceptable to the building official; and~~
- ~~3. The compressive strength of plain concrete walls shall be determined based on cores taken from each class of concrete wall. The location and number of tests shall be the same as those prescribed for tensile splitting strength tests in Sections A106.3.3.3 and A106.3.3.4, or in Section A108.1.~~

~~The use of materials not specified herein or in Section A108.1 shall be based on substantiating research data or engineering judgment, with the approval of the building official.~~

**[BS] A106.3 A106.2 Existing unreinforced masonry.**

**[BS] A106.3.1 A106.2.1 General.** Unreinforced masonry walls used to support vertical loads or seismic forces parallel and perpendicular to the wall plane shall be tested as specified in this section. Masonry that does not meet the minimum requirements established by this chapter shall be repaired, enhanced, removed and replaced with new materials, or alternatively, shall have its structural functions replaced with new materials and shall be anchored to supporting elements.



**[BS] 106.3.2 A106.2.2 Lay-up of walls.** Unreinforced masonry walls shall be laid in a running bond pattern.

**[BS] A106.3.2.1 A106.2.2.1 Multiwythe Header in multiple-wythe solid brick.** The facing and backing wythes of multiple-wythe walls shall be bonded so that not less than 10 percent of the exposed face area is composed of solid headers extending not less than 4 inches (102 mm) into the backing wythes. The clear distance between adjacent header courses shall not exceed 24 inches (610 mm) vertically or horizontally. Where backing consists of two or more wythes, the headers shall extend not less than 4 inches (102 mm) into the most distant wythe, or the backing wythes shall be bonded together with separate headers for which the area and spacing conform to the foregoing. Wythes of walls not meeting these requirements shall be considered to be veneer, and shall not be included in the effective thickness used in calculating the height-to-thickness ratio and the shear capacity strength of the wall.

**Exception:** Where SD1 is 0.3 g or less, veneer wythes anchored and made composite with backup masonry are permitted to be used for calculation of the effective thickness.

~~A106.3.2.2 Grouted or ungrouted hollow concrete or clay block and structural hollow clay tile. Grouted or ungrouted hollow concrete or clay block and structural hollow clay tile shall be laid in a running bond pattern.~~

**[BS] A106.3.2.3 A106.2.2.2 Other Lay-up patterns.** Lay-up patterns other than those specified in Section A106.2.2.1 are allowed if their performance can be justified.

**[BS] A106.3.3 A106.2.3 Testing of masonry.**

~~[BS] A106.3.3.1 Mortar tests. The quality of mortar in all masonry walls shall be determined by performing in place shear tests in accordance with the following:~~

- ~~1.—The bed joints of the outer wythe of the masonry shall be tested in shear by laterally displacing a single brick relative to the adjacent bricks in the same wythe. The head joint opposite the loaded end of the test brick shall be carefully excavated and cleared. The brick adjacent to the loaded end of the test brick shall be carefully removed by sawing or drilling and excavating to provide space for a hydraulic ram and steel loading blocks. Steel blocks, the size of the end of the brick, shall be used on each end of the ram to distribute the load to the brick. The blocks shall not contact the mortar joints. The load shall be applied horizontally, in the plane of the wythe. The load recorded at first movement of the test brick as indicated by spalling of the face of the mortar bed joints is  $V_{re}$ , in Equation A1-3.~~
- ~~2.—Alternative procedures for testing shall be used where in-place testing is not practical because of crushing or other failure mode of the masonry unit (see Section A106.3.3.2).~~

**[BS] A106.2.3.1 Concrete masonry units and structural clay load-bearing tile.** Grouted or ungrouted hollow concrete masonry units shall be tested in accordance with ASTM C140. Grouted or ungrouted structural clay load-bearing tile shall be tested in accordance with ASTM C67.

**[BS] A106.2.3.2 In-place mortar joint shear tests.** Mortar joint shear test values,  $v_{to}$ , shall be obtained by one of the following:

1. ASTM C1531.
2. For masonry walls that have high shear strength mortar, or where in-place testing is not practical because of crushing or other failure mode of the masonry, alternative procedures for testing shall be used in accordance with Section A106.2.3.2.

**[BS] A106.3.3.2 A106.2.3.3 Alternative procedures for testing masonry.** The tensile splitting tensile strength of existing masonry,  $f_{sp}$ , or the prism strength of existing masonry,  $f'_m$ , is permitted to be determined in accordance with ASTM C496 and calculated by the following ~~procedures:~~ equation:

$$f_{sp} = \frac{0.494P}{a_n} \quad \text{(Equation A1-1)}$$

- ~~1.—Wythes of solid masonry units shall be tested by sampling the masonry by drilled cores of not less than 8 inches (203 mm) in diameter. A bed joint intersection with a head joint shall be in the center of the core. The tensile splitting strength of these cores should be determined by the standard test method of ASTM C496. The core should be placed in the test apparatus with the bed joint 45 degrees (0.79 rad) from the horizontal. The tensile splitting strength should be determined by the following equation:~~
- ~~2.—Hollow unit masonry constructed through the wall units shall be tested by sampling the masonry by a sawn square prism of not less than 18 inches square (11 613 mm<sup>2</sup>). The tensile splitting strength should be determined by the standard test method of ASTM E519. The diagonal of the prism should be placed in a vertical position. The tensile splitting strength should be determined by the following equation:~~
- ~~3.—An alternative to material testing is estimation of the  $f'_m$  of the existing masonry. This alternative should be limited to recently constructed masonry. The determination of  $f'_m$  requires that the unit correspond to a specification of the unit by an ASTM standard and classification of the mortar by type.~~

**[BS] A106.3.3.3 A106.2.3.4 Location of tests.** The shear tests shall be taken at locations representative of the mortar conditions throughout the building, taking into account variations in workmanship at different building height levels, variations in weathering of the exterior surfaces, and variations in the condition of the interior surfaces due to deterioration caused by leaks and condensation of water and/or by the deleterious effects of other substances contained within the building. The exact test locations shall be determined at the building site by the engineer or architect in responsible charge of the structural design work. An accurate record of all such tests and their locations in the building shall be recorded, and these results shall be submitted to the building department for approval as part of the structural analysis.

Test locations shall be determined at the building site by the registered design professional in charge. Results of all tests and their locations shall be recorded.

**[BS] A106.3.3.4 A106.2.3.5 Number of tests.** The minimum number of tests per masonry class shall be determined as follows:

1. At each of both the first and top stories, not less than two tests per wall or line of wall elements providing a common line of resistance to seismic forces.
2. At each of all other stories, not less than one test per wall or line of wall elements providing a common line of resistance to seismic forces.
3. In any case, not less than one test per 1,500 square feet (139.4 m<sup>2</sup>) of wall surface and not less than a total of eight tests.

**[BS] A106.3.3.5 A106.2.3.6 Minimum quality of mortar.**

1. Mortar shear test values,  $v_{io}$ , in pounds per square inch (kPa), shall be obtained for each in-place shear test in accordance with the following equation:

$$v_{io} = (V_{test}/A_b) - P_{D+L} \quad \text{(Equation A1-2)}$$

where:

$V_{test}$  = Load at first observed movement.

$A_b$  = Total area of the bed joints above and below the test specimen.

$P_{D+L}$  = Stress resulting from actual dead plus live loads in place at the time of testing.

2. Individual unreinforced masonry walls with more than 50 percent of mortar test values,  $v_{io}$ , less than 30 pounds per square inch (207 kPa) shall be pointed prior to and retested.
3. The mortar shear strength,  $i_s$ , is the value in pounds per square inch (kPa) that is exceeded by 80 percent of the mortar shear test values,  $v_{io}$ .

The lower bound mortar shear strength,  $v_{L}$ , is defined as the mean minus one standard deviation of the mortar shear test values,  $v_{io}$ .

4. Unreinforced masonry with mortar shear strength,  $v_{L}$ , less than 30 pounds per square inch (207 kPa) shall be pointed and retested or shall have its structural function replaced, and shall be anchored to supporting elements in accordance with Sections A106.2.1 and A113.8. When existing mortar in any wythe is pointed to increase its shear strength and is retested, the condition of the mortar in the adjacent bed joints of the inner wythe or wythes and the opposite outer wythe shall be examined for extent of deterioration. The shear strength of any wall class shall be not greater than that of the weakest wythe of that class.

**[BS] A106.2.3.7 Minimum quality of masonry.** Where the alternative procedures of Section A106.2.3.2 are used to determine masonry quality, the following minimums apply:

1. The minimum average value of splitting tensile strength,  $f_{sp}$ , as calculated by Equation A1-1 shall be 50 pounds per square inch (344.7 kPa).
2. Individual unreinforced masonry walls with average splitting tensile strength of less than 50 pounds per square inch (344.7 kPa) shall be pointed and retested.
3. Hollow unit unreinforced masonry walls with estimated prism compressive strength of less than 1,000 pounds per square inch (6895 kPa) shall be grouted to increase the average net area compressive strength.

The lower-bound mortar strength  $f_{spL}$  is defined as the mean minus one standard deviation  $P_{D+L}$  of the splitting tensile test values  $f_{sp}$ .

**[BS] A106.3.3.7 A106.2.3.8 Collar joints.** The collar joints shall be inspected at the test locations during each in-place shear test, and estimates of the percentage of surfaces of the adjacent wythe that are covered with mortar shall be reported along with the results of the in-place shear tests.

**[BS] A106.3.3.8 A106.2.3.9 Unreinforced masonry classes.** Existing unreinforced masonry shall be categorized into one or more classes based on shear strength, quality of construction, state of *repair*, deterioration and weathering. A class shall be characterized by the masonry shear strength determined in accordance with Section A108.2. Classes are defined for whole walls, not for small areas of masonry within a wall. Discretion in the definition of classes of masonry is permitted to avoid unnecessary testing.

**[BS] A106.3.3.9 A106.2.3.10 Pointing.** Deteriorated mortar joints in unreinforced masonry walls shall be pointed in accordance with the following requirements:

1. **Joint preparation.** Deteriorated mortar shall be cut out by means of a tothing chisel or nonimpact power tool until sound mortar is reached, to a depth not less than  $\frac{3}{4}$  inch (19.1 mm) or twice the thickness of the joint, whichever is less, but not greater than 2 inches (50 mm). Care shall be taken not to damage the masonry edges. After cutting is complete, all loose material shall be removed with a brush, or air or water stream.
2. **Mortar preparation.** The mortar mix shall be proportioned as required by the construction specifications and manufacturer's *approved* instructions.
3. **Packing.** The joint into which the mortar is to be packed shall be dampened but without free-standing water. The mortar shall be tightly packed into the joint in layers not exceeding  $\frac{1}{4}$  inch (6.4 mm) deep until it is filled; then it shall be tooled to a smooth surface to match the original profile.

Nothing shall prevent pointing of any masonry wall joints before testing is performed in accordance with Section A106.2.3, except as required in Section A107.2.

## SECTION A107 QUALITY CONTROL

**[BS] A107.1 Pointing.** Preparation and mortar pointing shall be performed with special inspection.

**Exception:** At the discretion of the *code official*, incidental pointing may be performed without special inspection.

**[BS] A107.2 Masonry shear tests.** In-place masonry shear tests shall comply with Section A106.2.3.1. Testing of masonry for determination of splitting tensile strength shall comply with Section A106.2.3.3.

**[BS] A107.3 Existing wall anchors.** Existing wall anchors used as all or part of the required tension anchors shall be tested in pullout according to Section A107.5.1. Not fewer than four anchors tested per floor shall be tested in pullout, with not fewer than two tests at walls with joists framing into the wall and two tests at walls with joists parallel to the wall, but not less than 10 percent of the total number of existing tension anchors at each level.

**[BS] A107.4 New ~~bolts~~ wall anchors.** ~~All new embedded bolts~~ New wall anchors embedded in URM walls shall be subject to special inspection ~~in accordance with the building code~~ prior to placement of the ~~bolt~~ anchor and grout or adhesive in the drilled hole. Five percent of all anchors that do not extend through the wall shall be subject to a direct-tension test, and an additional 20 percent shall be tested using a calibrated torque wrench. Testing shall be performed in accordance with Section A107.5. ~~New bolts that extend through the wall with steel plates on the far side of the wall need not be tested.~~

New wall anchors embedded in URM walls resisting tension forces or a combination of tension and shear forces shall be subject to special inspection, prior to placement of the anchor and grout or adhesive in the drilled hole. Five percent of all anchors resisting tension forces shall be subject to a direct-tension test, and an additional 20 percent shall be tested using a calibrated torque wrench. Testing shall be performed in accordance with Section A107.5.

**Exception:**

~~Special inspection in accordance with the building code may be provided during installation of new anchors in lieu of testing.~~

~~All new embedded bolts resisting tension forces or a combination of tension and shear forces shall be subject to periodic special inspection in accordance with the building code, prior to placement of the bolt and grout or adhesive in the drilled hole. Five percent of all bolts resisting tension forces shall be subject to a direct tension test, and an additional 20 percent shall be tested using a calibrated torque wrench. Test~~

~~ing shall be performed in accordance with Section A107.5.  
New through bolts need not be tested.~~

New bolts that extend through the wall with steel plates on the far side of the wall need not be tested.

**[BS] A107.5 Tests of anchors in unreinforced masonry walls.** Tests of anchors in unreinforced masonry walls shall be in accordance with Sections A107.5.1 through A107.5.4 A107.5.3. Results of all tests shall be reported to the authority having jurisdiction. The report shall include the test results of maximum load for each test; pass-fail results; corresponding anchor size and type; orientation of loading; details of the anchor installation, testing apparatus and embedment; wall thickness; and joist orientation and proximity to the tested anchor.

**[BS] A107.5.1 Direct tension testing of existing anchors and new anchors.** The test apparatus shall be supported by the masonry wall. The test procedure for prequalification of tension and shear anchors shall comply with ASTM E488. Existing wall anchors shall be given a preload of 300 pounds (1335 N) before establishing a datum for recording elongation. The tension test load reported shall be recorded at  $1/8$  inch (3.2 mm) relative movement between the existing anchor and the adjacent masonry surface. New embedded tension anchors shall be subject to a direct tension load of not less than 2.5 times the design load but not less than 1,500 pounds (6672 N) for 5 minutes. ~~(10 percent deviation).~~

**Exception:** Where obstructions occur, the distance between the anchor and the test apparatus support shall be not less than one-half the wall thickness for existing anchors and 75 percent of the embedment length for new embedded anchors.

**[BS] A107.5.2 Torque testing of new bolts-anchors.** ~~Bolts~~ Anchors embedded in unreinforced masonry walls shall be tested using a torque-calibrated wrench to the following minimum torques:

- $1/2$ -inch-diameter (12.7 mm) bolts: 40 foot pounds (54.2 N-m).
- $5/8$ -inch-diameter (15.9 mm) bolts: 50 foot pounds (67.8 N-m).
- $3/4$ -inch-diameter (19.1 mm) bolts: 60 foot pounds (81.3 N-m).

**[BS] A107.5.3 Prequalification test for bolts and other types of anchors.**

~~This section is applicable when it is desired to use tension or shear values for anchors greater than those permitted by Table A1-E. The direct tension test procedure set forth in Section A107.5.1 for existing anchors shall be used to determine the allowable tension values for new embedded through bolts, except that no preload is required. Bolts shall be installed in the same manner and using the same materials as will be used in the actual construction. A minimum of five tests for each bolt size and type shall be performed for each class of masonry in which they are proposed to be used. The allowable tension values for such anchors shall be the lesser of the average ultimate load divided by a safety factor of 5.0 or the average load at which  $1/8$  inch (3.2 mm) elongation occurs for each size and type of bolt and class of masonry. The test procedure for prequalification of shear bolts shall comply with ASTM E488 or another approved procedure. The allowable values determined in this manner shall be permitted to exceed those set forth in Table A1-E.~~

ASTM E488 or the test procedure in Section A107.5.1 is permitted to be used to determine tension or shear strength values for anchors greater than those permitted by Table A108.1(2). Anchors shall be installed in the same manner and using the same materials as will be used in the actual construction. Not fewer than five tests for each bolt size and type shall be performed for each class of masonry in which they are proposed to be used. The tension and shear strength values for such anchors shall be the lesser of the average ultimate load divided by 5.0 or the average load at which  $1/8$  inch (3.2 mm) elongation occurs for each size and type of anchor and class of masonry.

~~**[BS] A107.5.4 Reports.** Results of all tests shall be reported. The report shall include the test results as related to anchor size and type, orientation of loading, details of the anchor installation and embedment, wall thickness and joist orientation.~~

## SECTION A108 DESIGN STRENGTHS

**[BS] A108.1 Strength values.**

1. Strength values for existing materials are given in Table ~~A1-D~~ A108.1(1) and for new materials in Table ~~A1-E~~ A108.1(2).
2. ~~Capacity reduction factors need not be used.~~

The strength reduction factor,  $\Phi$ , shall be taken equal to 1.0.

4. The use of **new** materials not specified herein shall be based on substantiating research data or engineering judgment, as *approved* by the *code official*.

**NOTE to RCC**

Table A108.1(1) is formerly Table A1-D

**[BSI] TABLE A108.1(1)  
STRENGTH VALUES FOR EXISTING MATERIALS**

| EXISTING MATERIALS OR CONFIGURATION OF MATERIALS <sup>a</sup>              |  | STRENGTH VALUES                                    |
|--|--|--|
|  |  | x 14.594 for N/m                                   |
| <u>Horizontal diaphragms</u>   | <u>Roofs with straight sheathing and roofing applied directly to the sheathing.</u>                        | 300 lbs. per ft. for seismic shear                 |
|  | <u>Roofs with diagonal sheathing and roofing applied directly to the sheathing.</u>                        | 750 lbs. per ft. for seismic shear                 |
|  | <u>Floors with straight tongue-and-groove sheathing.</u>   | 300 lbs. per ft. for seismic shear                 |
|  | <u>Floors with straight sheathing and finished wood flooring with board edges offset or perpendicular.</u> | 1,500 lbs. per ft. for seismic shear               |
|  | <u>Floors with diagonal sheathing and finished wood flooring.</u>  | 1,800 lbs. per ft. for seismic shear               |
|  | <u>Metal deck welded with minimal welding.<sup>c</sup></u>   | 1,800 lbs. per ft. for seismic shear               |
|  | <u>Metal deck welded for seismic resistance.<sup>d</sup></u>   | 3,000 lbs. per ft. for seismic shear               |
| <u>Crosswalls<sup>b</sup></u>  | <u>Plaster on wood or metal lath.</u>  | 600 lbs. per ft. for seismic shear                 |
|  | <u>Plaster on gypsum lath.</u>   | 550 lbs. per ft. for seismic shear                 |
|  | <u>Gypsum wallboard, unblocked edges.</u>  | 200 lbs. per ft. for seismic shear                 |
|  | <u>Gypsum wallboard, blocked edges.</u>  | 400 lbs. per ft. for seismic shear                 |
| <u>Existing footing, wood framing, structural steel, reinforcing steel</u> | <u>Plain concrete footings.</u>  | $f'_c = 1,500$ psi unless otherwise shown by tests |
|  | <u>Douglas fir wood.</u>   | Same as D.F. No. 1                                 |
|  | <u>Reinforcing steel.</u>  | $F_y = 40,000$ psi maximum                         |
|  | <u>Structural steel.</u>   | $F_y = 33,000$ psi maximum                         |

For SI: 1 inch = 25.4 mm, 1 square inch = 645.16 mm<sup>2</sup>, 1 pound = 4.4 N, 1 pound per square inch = 6894.75 N/m<sup>2</sup>, 1 pound per foot = 14.43 N/m.

a. Material must be sound and in good condition.

b. Shear values of these materials may be combined, except the total combined value should not exceed 900 pounds per foot.

c. Minimum 22-gage steel deck with welds to supports satisfying the standards of the Steel Deck Institute.

d. Minimum 22-gage steel deck with <sup>3</sup>/<sub>4</sub>-inch diameter plug welds at an average spacing not exceeding 8 inches and with sidlap welds appropriate for the deck span.

**NOTE to RCC**

Table A108.1(2) is formerly Table A1-E

**[BSI] TABLE A108.1(2)  
STRENGTH VALUES OF NEW MATERIALS USED IN CONJUNCTION WITH EXISTING CONSTRUCTION**

| NEW MATERIALS OR CONFIGURATION OF MATERIALS |  | STRENGTH VALUES  |
|---|--|------------------|
| <u>Horizontal diaphragms</u>                | <u>Plywood sheathing applied directly over existing straight sheathing with ends of plywood sheets bearing on joists or rafters and edges of plywood located on center of individual sheathing boards.</u> | 675 lbs. per ft. |

|   |  |   |
|---|--|---|
| <u>Crosswalls</u>                                     | <u>Plywood sheathing applied directly over wood studs; no value should be given to plywood applied over existing plaster or wood sheathing.</u>  | <u>1.2 times the value specified in the current building code.</u>  |
|   | <u>Drywall or plaster applied directly over wood studs.</u>  | <u>The value specified in the current building code.</u>  |
|   | <u>Drywall or plaster applied to sheathing over existing wood studs.</u>   | <u>50 percent of the value specified in the current building code.</u>  |
| <u>Tension anchors<sup>f</sup></u>                    | <u>Anchors extending entirely through unreinforced masonry wall secured with bearing plates on far side of a wall 30 square inches of area.<sup>b, c</sup></u>   | <u>5,400 lbs. per anchor for three-wythe minimum walls.<br/>2,700 lbs. for two-wythe walls.</u>   |
| <u>Shear bolts<sup>e, f</sup></u>                     | <u>Anchors embedded not less than 8 inches into unreinforced masonry walls; anchors should be centered in 2 1/2-inch-diameter holes with dry-pack or nonshrink grout around the circumference of the anchor.</u>                                 | <u>The value for plain masonry specified for solid masonry TMS 402; and no value larger than those given for 3/4-inch bolts should be used.</u> |
| <u>Combined tension and shear anchors<sup>f</sup></u> | <u>Through-anchors—anchors meeting the requirements for shear and for tension anchors.<sup>b, c</sup></u>  | <u>Tension—same as for tension anchors.<br/>Shear—same as for shear anchors.</u>  |
|   | <u>Embedded anchors—anchors extending to the exterior face of the wall with a 2 1/2-inch round plate under the head and drilled at an angle of 22 1/2 degrees to the horizontal; installed as specified for shear anchors.<sup>a, b, c</sup></u> | <u>Tension—3,600 lbs. per anchor.<br/>Shear—same as for shear anchors.</u>  |
| <u>Infilled walls</u>                                 | <u>Reinforced masonry infilled openings in existing unreinforced masonry walls; provide keys or dowels to match reinforcing.</u>   | <u>Same as values specified for unreinforced masonry walls.</u>   |
| <u>Reinforced masonry<sup>d</sup></u>                 | <u>Masonry piers and walls reinforced per the current building code.</u>   | <u>The value specified in the current building code for strength design.</u>  |
| <u>Reinforced concrete<sup>d</sup></u>                | <u>Concrete footings, walls and piers reinforced as specified in the current building code.</u>  | <u>The value specified in the current building code for strength design.</u>  |

For SI: 1 inch = 25.4 mm, 1 square inch = 645.16 mm<sup>2</sup>, 1 pound = 4.4 N, 1 degree = 0.017 rad, 1 pound per foot = 14.43 N/m, 1 foot = 304.8 mm.

a. Embedded anchors to be tested as specified in Section A107.4.

b. Anchors shall be 1/2 inch minimum in diameter.

c. Drilling for anchors shall be done with an electric rotary drill; impact tools should not be used for drilling holes or tightening anchors and shear bolt nuts.

d. Load factors or capacity reduction factors shall not be used.

e. Other bolt sizes, values and installation methods may be used, provided that a testing program is conducted in accordance with Section A107.5.3. The strength value shall be determined by multiplying the calculated allowable value, determined in accordance with Section A107.5.3, by 3.0, and the usable value shall be limited to not greater than 1.5 times the value given in the table. Bolt spacing shall not exceed 6 feet on center and shall be not less than 12 inches on center.

f. An alternative adhesive anchor bolt system is permitted to be used providing: its properties and installation conform to an ICC Evaluation Service Report; and the report states that the system's use is in unreinforced masonry as an acceptable alternative to Sections A107.4 and A113.1 or TMS 402, Section 2.1.4. The report's allowable values shall be multiplied by a factor of three to obtain strength values and the strength reduction factor, F, shall be taken equal to 1.0.

**[BS] A108.2 Masonry shear strength.** The unreinforced masonry shear strength,  $v_{mL}$ , shall be determined for each masonry class from one of the following equations:

1. The unreinforced masonry shear strength,  $v_{mL}$ , shall be determined by Equation A1-4 when the mortar shear strength has been determined by Section A106.3.3.1.

$$v_m = 0.56v_t + \frac{0.75P_D}{A} \quad \text{(Equation A1-4)}$$

When testing is performed in accordance with Section A106.2.3.1, the unreinforced masonry shear strength,  $v_m$ , shall be determined by Equation A1-3.

$$v_{mL} = \frac{0.75 \left( 0.75 v_{tL} \frac{P_D}{A_n} \right)}{1.5} \quad \text{(Equation A1-3)}$$

The mortar shear strength values,  $v_{tL}$ , shall be determined in accordance with Section A106.2.3.6.

2. The unreinforced masonry shear,  $v_m$ , shall be determined by Equation A1-5 when tensile splitting strength has been determined in accordance with Section A 106.3.3.2, Item 1 or 2.

$$v_m = 0.8 f_{sp} + 0.5 \frac{P_D}{A} \quad \text{(Equation A1-5)}$$

When alternate testing is performed in accordance with Section A106.2.3.3, unreinforced masonry shear,  $v_{mL}$ , shall be determined by Equation A1-4.

$$v_{mL} = \frac{0.75 \left( f_{sp} + \frac{P_D}{A_n} \right)}{1.5} \quad \text{(Equation A1-4)}$$

3. When  $f_m$  has been estimated by categorization of the units and mortar in accordance with Section 2105.1 of the *International Building Code*, the unreinforced masonry shear strength,  $v_m$ , shall not exceed 200 pounds per square inch (1380 kPa) or the lesser of the following:

- a)  $2.5 \sqrt{f'_m}$  or
- b) 200 psi or
- c)  $v + 0.75 \frac{P_D}{A}$  (Equation A1-6)

For SI: 1 psi = 6.895 kPa.

where:

$v$  = 62.5 psi (430 kPa) for running bond masonry not grouted solid.

$v$  = 100 psi (690 kPa) for running bond masonry grouted solid.

$v$  = 25 psi (170 kPa) for stack bond grouted solid.

**[BS] A108.3 Masonry compression.** Where any increase in dead plus live compression stress occurs, the compression stress in unreinforced masonry shall not exceed 300 pounds per square inch (2070 kPa).

**[BS] A108.4 Masonry tension.** Unreinforced masonry shall be assumed to have no tensile capacity.

**[BS] A108.5 Existing tension anchors.** The resistance values of the existing anchors shall be the average of the tension

**[BS] A108.5 Wall tension anchors.** The tension strength of wall anchors shall be the average of the tension test values for anchors having the same wall thickness and framing orientation.

**[BS] A108.6 Foundations.** For existing foundations, new total dead loads are permitted to be increased over the existing dead load by 25 percent. New total dead load plus live load plus seismic forces may be increased over the existing dead load plus live load by 50 percent. Higher values may be justified only in conjunction with a geotechnical investigation.

## SECTION A109 ANALYSIS AND DESIGN PROCEDURE DESIGN STRENGTH

**[BS] A109.1 General.** The elements of buildings hereby required to be analyzed are specified in Table ~~A1-A~~ A110.1.

**[BS] A109.2 Selection of procedure.** Buildings with rigid diaphragms shall be analyzed by the general procedure of Section A110, which is based on the building code. Buildings with flexible diaphragms shall be analyzed by the general procedure or, when applicable, may be analyzed by the special procedure of Section A111.

## SECTION A110 GENERAL PROCEDURE

**[BS] A110.1 Minimum design lateral forces.** Buildings shall be analyzed to resist minimum lateral forces assumed to act nonconcurrently in the direction of each of the main axes of the structure in accordance with the following:

$$V = \frac{0.75S_{DS}W}{R} \quad \text{(Equation ~~A1-7~~ A1-5)}$$

**[BS] A110.2 Lateral Seismic forces on elements of structures.**

Parts and portions of a structure not covered in Section A110.3 shall be analyzed and designed per the current building code, using force levels defined in Section A110.1.

### Exceptions:

- I. Unreinforced masonry walls for which height-to- thickness ratios do not exceed ratios set forth in Table ~~A1-B~~ A110.3 need not be analyzed for out-of-plane loading. Unreinforced masonry walls that exceed the allowable *hit* ratios of Table ~~A1-B~~ A110.2 shall be braced according to Section A113.5.
2. Parapets complying with Section A113.6 need not be analyzed for out-of-plane loading.
3. Where walls are to be anchored to flexible floor and roof diaphragms, the anchorage shall be in accordance with Section A113.1.

### NOTE to RCC

Table A110.2 is formerly Table A1-B



**[BS] TABLE A110.2 ALLOWABLE VALUE OF HEIGHT-TO-THICKNESS RATIO OF UNREINFORCED MASONRY WALLS**

| WALL TYPES                                    | $0.13g \leq S_{D1} < 0.25g$ | $0.25g \leq S_{D1} < 0.4g$ | $S_{D1} \geq 0.4g$ BUILDINGS WITH CROSSWALLS <sup>a</sup> | $S_{D1} \geq 0.4g$ ALL OTHER BUILDINGS |
|---|-----------------------------|----------------------------|---|--|
| Walls of one-story buildings                  | 20                          | 16                         | 16 <sup>b, c</sup>  | 13                                     |
| First-story wall of multiple-story building   | 20                          | 18                         | 16  | 15                                     |
| Walls in top story of multiple-story building | 14                          | 14                         | 14 <sup>b, c</sup>  | 9                                      |
| All other walls                               | 20                          | 16                         | 16  | 13                                     |

For SI: 1 pound per square inch = 6894.75 N/m<sup>2</sup>.

- Applies to the special procedures of Section A111 only. See Section A111.7 for other restrictions.
- This value of height-to-thickness ratio shall be used where mortar shear tests establish a tested mortar shear strength,  $v_s$ , of not less than 100 pounds per square inch. This value shall also be used where the tested mortar shear strength is not less than 60 pounds per square inch, and where a visual examination of the collar joint indicates not less than 50-percent mortar coverage.
- Where a visual examination of the collar joint indicates not less than 50-percent mortar coverage, and the tested mortar shear strength,  $v_s$ , is greater than 30 pounds per square inch but less than 60 pounds per square inch, the allowable height-to-thickness ratio may be determined by linear interpolation between the larger and smaller ratios in direct proportion to the tested mortar shear strength.

**[BS] A110.3 In-plane loading of URM shear walls and frames.** Vertical lateral load-resisting elements shall be analyzed in accordance with Section A112.

**[BS] A110.4 Redundancy and overstrength factors.** Any redundancy or overstrength factors contained in the building code may be taken as unity. The vertical component of earth-quake load (EJ) may be taken as zero.

## SECTION A111 SPECIAL PROCEDURE

**[BS] A111.1 Limits for the application of this procedure.** The special procedures of this section may be applied only to buildings having the following characteristics:

- Flexible diaphragms at all levels above the base of the structure.
- Vertical elements of the lateral force-resisting system consisting predominantly of masonry or concrete shear walls.
- Except for single-story buildings with an open front on one side only, a minimum of two lines of vertical elements of the lateral force-resisting system parallel to each axis of the building (see Section A111.8 for open-front buildings).

**[BS] A111.2 Lateral Seismic forces on elements of structures.** With the exception of the provisions in Sections A111.4 through A111.7, elements of structures shall comply with Sections A110.2 through A110.4.

**[BS] A111.3 Crosswalls.** Crosswalls shall meet the requirements of this section.

**[BS] A111.3.1 Crosswall definition.** A crosswall is a wood-framed wall sheathed with any of the materials described in Table A110.1 or A110.2 or A108.1(1) or A108.1(2) or other system as defined in Section A111.3.5. Crosswalls shall be spaced no more than 40 feet (12 192 mm) on center measured perpendicular to the direction of consideration, and shall be placed in each story of the building. Crosswalls shall extend the full story height between diaphragms.

### Exceptions:

- Crosswalls need not be provided at all levels when used in accordance with Section A111.4.2, Item 4.
- Existing crosswalls need not be continuous below a wood diaphragm at or within 4 feet (1219 mm) of grade, provided:
  - Shear connections and anchorage requirements of Section A111.5 are satisfied at all edges of the diaphragm.

- 2.2. Crosswalls with total shear capacity of  $0.5SDI Wd$  interconnect the diaphragm to the foundation.
- 2.3. The demand-capacity ratio of the diaphragm between the crosswalls that are continuous to their foundations does not exceed 2.5, calculated as follows:

$$DCR = \frac{(2.1SDI Wd + V_{eq})}{2v_l D}$$

(Equation A1-8-A1-6)

**[BS] All.3.2 Crosswall shear capacity.** Within any 40 feet (12 192 mm) measured along the span of the diaphragm, the sum of the crosswall shear capacities shall be at least 30 percent of the diaphragm shear capacity of the strongest diaphragm at or above the level under consideration-

**BS] All.3.3 Existing crosswalls.** Existing crosswalls shall have a maximum height-to-length ratio between openings of 1.5 to 1. Existing crosswall connections to diaphragms need not be investigated as long as the cross-wall extends to the framing of the diaphragms above and below.

**[BS] All.3.4 New crosswalls.** New crosswall connections to the diaphragm shall develop the crosswall shear capacity. New crosswalls shall have the capacity to resist an overturning moment equal to the crosswall shear capacity times the story height. Crosswall overturning moments need not be cumulative over more than two stories.

**[BS] All.3.5 Other crosswall systems.** Other systems, such as moment-resisting frames, may be used as cross-walls provided that the yield story drift does not exceed 1 inch (25 mm) in any story.

[BS] All.4 Wood diaphragms.

**[BS] All.4.1 Acceptable diaphragm span.** A diaphragm is acceptable if the point  $(L, DCR)$  on Figure A1-4 A111.4.1 falls within Region 1, 2 or 3.

**NOTE to RCC**

**Table A111.4.1 is formerly Table A1-1**

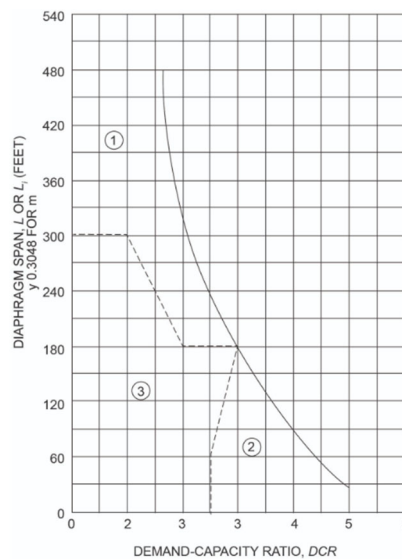

1. Region of demand-capacity ratios where crosswalls may be used to increase  $h/t$  ratios.
2. Region of demand-capacity ratios where  $h/t$  ratios of "buildings with crosswalls" may be used, whether or not crosswalls are present.
3. Region of demand-capacity ratios where  $h/t$  ratios of "all other buildings" shall be used, whether or not crosswalls are present.

For SI: 1 foot = 304.8 mm.

[BS] FIGURE A111.4.1 ACCEPTABLE DIAPHRAGM SPAN

**[BS] All.4.2 Demand-capacity ratios.** Demand-capacity ratios shall be calculated for the diaphragm at any level according to the following formulas:

1. For a diaphragm without qualifying crosswalls at levels immediately above or below:

$$DCR = 2.1S_{D1}W_d/\Sigma v_u D \quad (\text{Equation } \del{A1-9} \underline{A1-7})$$

2. For a diaphragm in a single-story building with qualifying crosswalls, or for a roof diaphragm coupled by crosswalls to the diaphragm directly below:

$$DCR = 2.1SDIW/J_v D + Vcb \quad (\text{Equation } \del{A1-10} \underline{A1-8})$$

3. For diaphragms in a multistory building with qualifying crosswalls in all levels:

$$DCR = 2.1S_0/12W_j(I.I.vuD + Vc_6)$$

(Equation ~~A1-11~~ A1-9)

*DCR* shall be calculated at each level for the set of diaphragms at and above the level under consideration. In addition, the roof diaphragm shall also meet the requirements of Equation A1-10.

4. For a roof diaphragm and the diaphragm directly below, if coupled by crosswalls:

$$DCR = 2.1S_{D1}\Sigma W_d/\Sigma v_u D \quad (\text{Equation } \del{A1-12} \underline{A1-10})$$

**[BS] All.4.3 Chords.** An analysis for diaphragm flexure need not be made, and chords need not be provided.

**[BS] All.4.4 Collectors.** An analysis of diaphragm collector forces shall be made for the transfer of diaphragm edge shears into vertical elements of the lateral force-resisting system. Collector forces may be resisted by new or existing elements.

**[BS] All.4.5 Diaphragm openings.**

1. Diaphragm forces at corners of openings shall be investigated and shall be developed into the diaphragm by new or existing materials.
2. In addition to the demand-capacity ratios of Section A11.4.2, the demand-capacity ratio of the portion of the diaphragm adjacent to an opening shall be calculated using the opening dimension as the span.
3. Where an opening occurs in the end quarter of the diaphragm span, the calculation of  $v_u P$  for the demand-capacity ratio shall be based on the net depth of the diaphragm.

~~**[BS] All.5 Diaphragm shear transfer.**~~ Diaphragms shall be connected to shear walls with connections capable of developing the diaphragm-loading tributary to the shear wall given by the lesser of the following formulas:

$$V = 1.2S_o, cpwd$$

(Equation ~~A1-13~~ A1-11)

using the *CP* values in Table ~~A1-C~~ A111.5, or

$$V = v_u D$$

(Equation ~~A1-14~~ A1-12)

**NOTE to RCC**

Table A111.5 is formerly Table A1-C

[BS] TABLE A111.5 HORIZONTAL FORCE FACTOR,  $C_p$

| CONFIGURATION OF MATERIALS  | $C_p$ |
|---|-------|
| Roofs with straight or diagonal sheathing and roofing applied directly to the sheathing, or floors with straight tongue-and-groove sheathing. | 0.50  |
| Diaphragms with double or multiple layers of boards with edges offset, and blocked plywood systems.   | 0.75  |
| Diaphragms of metal deck without topping:   |       |
| Minimal welding or mechanical attachment.   | 0.6   |
| Welded or mechanically attached for seismic resistance.   | 0.68  |

[BS] A111.6 Shear walls (In-plane loading).

[BS] A111.6.1 **Wall story force.** The wall story force distributed to a shear wall at any diaphragm level shall be the lesser value calculated as:

$$F_{wx} = 0.8S_{DI}(W_{wx} + W_d/2) \quad (\text{Equation A1-15 A1-13})$$

but need not exceed

$$F_{wx} = 0.8S_{DI}W_{wx} + v_u D \quad (\text{Equation A1-16 A1-14})$$

[BS] A111.6.2 **Wall story shear.** The wall story shear shall be the sum of the wall story forces at and above the level of consideration.

$$V_{wx} = \sum F_{wx} \quad (\text{Equation A1-17 A1-15})$$

[BS] A111.6.3 **Shear wall analysis.** Shear walls shall comply with Section A112.

~~[BS] A111.6.4 **Moment frames.** Moment frames used in place of shear walls shall be designed as required by the building code, except that the forces shall be as specified in Section A111.6.1, and the story drift ratio shall be limited to 0.015, except as further limited by Section A112.4.2.~~

**[BS] A111.6.4 New seismic force-resisting elements.** New seismic force-resisting elements such as moment frames, braced frames or shear walls shall be designed as required by the building code, except that the seismic forces shall be as specified in Section A111.6.1, and the story drift ratio shall be limited to 0.015, except as further limited by Section A112.4.2 for moment frames.

[BS] A111.7 Out-of-plane forces-unreinforced masonry walls.

[BS] A111.7.1 **Allowable unreinforced masonry wall height-to-thickness ratios.** The provisions of Section A110.2 are applicable, except the allowable height-to-thickness ratios given in Table A1-B A110.2 shall be determined from Figure A1-1 A114.1 as follows:

1. In Region 1, height-to-thickness ratios for buildings with crosswalls may be used if qualifying crosswalls are present in all stories.
2. In Region 2, height-to-thickness ratios for buildings with crosswalls may be used whether or not qualifying crosswalls are present.
3. In Region 3, height-to-thickness ratios for "all other buildings" shall be used whether or not qualifying crosswalls are present.

[BS] A111.7.2 **Walls with diaphragms in different regions.** When diaphragms above and below the wall under consideration have demand-capacity ratios in different regions of Figure A1-1 A111.4.1, the lesser height-to-thickness ratio shall be used.

**[BS] All.8 Open-front design procedure.** A single-story building with an open front on one side and crosswalls parallel to the open front may be designed by the following procedure:

1. Effective diaphragm span,  $L_i$ , for use in Figure A1-1 A111.4.1 shall be determined in accordance with the following formula:

$$L_i = 2[(W_w/W_d)L + L] \quad \text{(Equation A1-18-A1-16)}$$

2. Diaphragm demand-capacity ratio shall be calculated as:

$$DCR = 2.1S_o < W_d + W_{Jl}[(v_{,D}) + v_{cb}]$$

$$\text{(Equation A1-19 A1-17)}$$

## SECTION A112 ANALYSIS AND DESIGN

**[BS] A112.1 General.** The following requirements are applicable to both the general procedure and the special procedure for analyzing vertical elements of the lateral force-resisting system.

**[BS] A112.2 Existing In-plane shear of unreinforced masonry walls.**

**[BS] A112.2.1 Flexural rigidity.** Flexural components of deflection may be neglected in determining the rigidity of an unreinforced masonry wall.

**[BS] A112.2.2 Shear walls with openings.** Wall piers shall be analyzed according to the following procedure, which is diagrammed in Figure A1-2-A112.2.2

1. For any pier,

- 1.1. The pier shear capacity shall be calculated as:

$$V_a = v_{,All.5} \quad \text{(Equation A1-20-A1-18)}$$

- 1.2. The pier rocking shear capacity shall be calculated as:

$$V_r = 0.9PoDIH \quad \text{(Equation A1-21-A1-19)}$$

2. The wall piers at any level are acceptable if they comply with one of the following modes of behavior:

- 2.1. Rocking controlled mode. When the pier rocking shear capacity is less than the pier shear capacity, i.e.,  $V_r < V_a$  for each pier in a level, forces in the wall at that level,  $V_{wx}$  shall be distributed to each pier in proportion to  $PoDIH$ .

For the wall at that level:

$$0.7V_{wx} < i.v, \quad \text{(Equation A1-22-A1-20)}$$

- 2.2 Shear controlled mode. Where the pier shear capacity is less than the pier rocking capacity, i.e.,  $V_a < V_r$ , in at least one pier in a level

forces in the wall at the level,  $V_{wx}'$  shall be distributed to each pier in proportion to  $DIH$ .

For each pier at that level:

$$\text{(Equation A1-23-A1-21)}$$

$$V_p < V_a$$

and

$$VP < V, \quad \text{(Equation A1-24-A1-22)}$$

If  $V_p < V_a$  for each pier and  $V_p > V$ , for one or more piers, such piers shall be omitted from the analysis, and the procedure shall be repeated

for the remaining piers, unless the wall is strengthened and reanalyzed.

3. Masonry pier tension stress. Unreinforced masonry wall piers need not be analyzed for tension stress.

[BS] A112.2.3 **Shear walls without openings.** Shear walls without openings shall be analyzed the same as for walls with openings, except that  $V_r$  shall be calculated as follows:

$$V_r = 0.9(P_O + 0.SPIV)D/H \quad \text{(Equation A1-25-A1-23)}$$

**NOTE to RCC**

Figure A112.2.2 is formerly Table A1-2

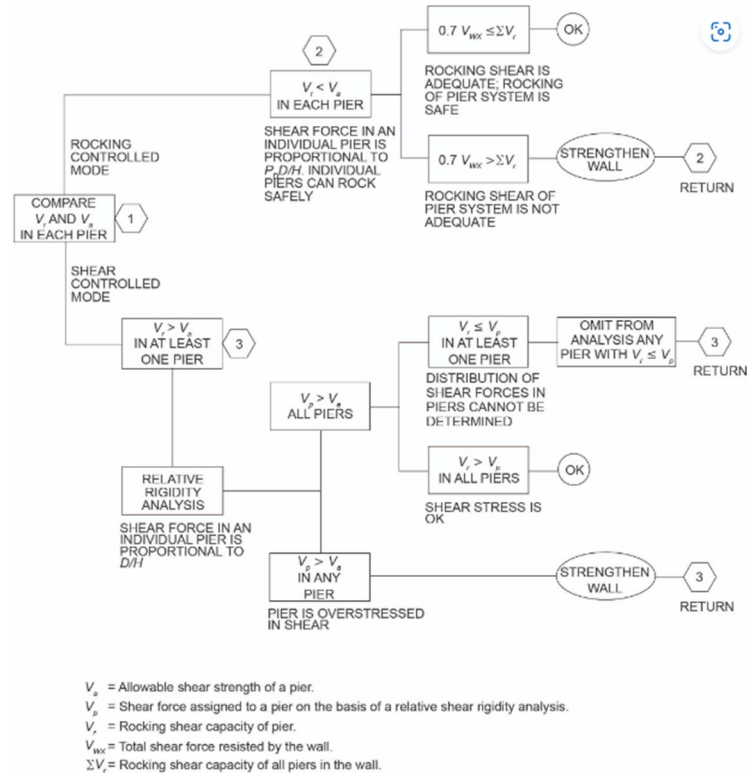

[BS] FIGURE A112.2.2 ANALYSIS OF URM WALL IN-PLANE SHEAR FORCES

[BS] A112.3 **Plywood-sheathed shear walls.** Plywood-sheathed shear walls may be used to resist lateral forces for buildings with flexible diaphragms analyzed according to provisions of Section A1 11. Plywood-sheathed shear walls may not be used to share lateral forces with other materials along the same line of resistance.

[BS] A112.4 **Combinations of vertical elements.**

[BS] A112.4.1 **Lateral-~~Seismic~~ force distribution.** Lateral forces shall be distributed among the vertical-resisting elements in proportion to their relative rigidities, except that moment-resisting frames shall comply with Section A112.4.2.

[BS] A112.4.2 **Moment-resisting frames.** Moment-resisting frames shall not be used with an unreinforced masonry wall in a single line of resistance unless the wall has piers that have adequate shear capacity to sustain rocking in accordance with Section A1 12.2.2. The frames shall be designed in accordance with the building code to carry 100 percent of the lateral seismic forces tributary to that line of resistance, as determined from Equation A1-7 Section A111.2. The story drift ratio shall be limited to 0.0075.

SECTION A113

DETAILED SYSTEM DESIGN REQUIREMENTS

[BS] A113.1 **Wall anchorage.**

[BS] A113.1.1 **Anchor locations.** Unreinforced masonry walls shall be anchored at the roof and floor levels as required in Section

A110.2. Ceilings of plaster or similar materials, when not attached directly to roof or floor framing and where abutting masonry walls, shall either be anchored to the walls at a maximum spacing of 6 feet (1829 mm), or be removed.

**[BS] A113.1.2 Anchor requirements.** Anchors shall consist of bolts installed through the wall as specified in Table A1-E A108.1(2), or an approved equivalent at a maximum anchor spacing of 6 feet (1829 mm). All wall anchors shall be secured to the joists to develop the required forces.

**[BS] A113.1.3 Minimum wall anchorage.** Anchorage of masonry walls to each floor or roof shall resist a minimum force determined as  $0.9S_{05}$  times the tributary weight or 200 pounds per linear foot (2920 *Nim*), whichever is greater, acting normal to the wall at the level of the floor or roof. Existing wall anchors, if used, must meet the requirements of ~~this chapter~~ Section A107.5.1 or must be upgraded.

**[BS] A113.1.4 Anchors at corners.** At the roof and floor levels, both shear and tension anchors shall be provided within 2 feet (610 mm) horizontally from the inside of the corners of the walls.

**[BS] A113.2 Diaphragm shear transfer.** Bolts transmitting shear forces shall have a maximum bolt spacing of 6 feet (1829 mm) and shall have nuts installed over malleable iron or plate washers when bearing on wood, and heavy-cut washers when bearing on steel.

**[BS] A113.3 Collectors.** Collector elements shall be provided that are capable of transferring the seismic forces originating in other portions of the building to the element providing the resistance to those forces.

**[BS] A113.4 Ties and continuity.** Ties and continuity shall conform to the requirements of the building code.

**[BS] A113.5 Wall bracing.**

**[BS] A113.S.1 General.** Where a wall height-to-thickness ratio exceeds the specified limits, the wall may be laterally supported by vertical bracing members per Section A1 13.5.2 or by reducing the wall height by bracing per Section A1 13.5.3.

**[BS] A113.S.2 Vertical bracing members.** Vertical bracing members shall be attached to floor and roof construction for their design loads independently of required wall anchors. Horizontal spacing of vertical bracing members shall not exceed one-half of the unsupported height of the wall or 10 feet (3048 mm). Deflection of such bracing members at design loads shall not exceed one-tenth of the wall thickness.

**[BS] A113.S.3 Intermediate wall bracing.** The wall height may be reduced by bracing elements connected to the floor or roof. Horizontal spacing of the bracing elements and wall anchors shall be as required by design, but shall not exceed 6 feet (1829 mm) on center. Bracing elements shall be detailed to minimize the horizontal displacement of the wall by the vertical displacement of the floor or roof.

**[BS] A113.6 Parapets.** Parapets and exterior wall appendages not conforming to this chapter shall be removed, or stabilized or braced to ensure that the parapets and appendages remain in their original positions.

The maximum height of an unbraced unreinforced masonry parapet above the lower of either the level of tension anchors or the roof sheathing shall not exceed the height-to-thickness ratio shown in Table A1-F A113.6. If the required parapet height exceeds this maximum height, a bracing system designed for the forces determined in accordance with the building code shall support the top of the parapet. Parapet corrective work must be performed in conjunction with the installation of tension roof anchors.

The ~~minimum~~ height of a URM parapet above any wall anchor shall be not less than 12 inches (305 mm).

**Exception:** If a reinforced concrete beam is provided at the top of the wall, the minimum height above the wall anchor may be 6 inches (152 mm).

**NOTE to RCC**

**Table A113.6 is formerly Table A1-F**

**[BS] TABLE A113.6  
MAXIMUM ALLOWABLE HEIGHT-TO-THICKNESS RATIO FOR PARAPETS**

|  | $S_{D1}$                       |                            |                    |
|--|--------------------------------|----------------------------|--------------------|
|  | $0.13g \leq S_{D1} \leq 0.25g$ | $0.25g \leq S_{D1} < 0.4g$ | $S_{D1} \geq 0.4g$ |
| Maximum allowable height-to-thickness ratios | 2.5                            | 2.5                        | 1.5                |

[BS] A113.7 Veneer.

1. Veneer shall be anchored with approved anchor ties conforming to the required design capacity specified in the building code and shall be placed at a maximum spacing of 24 inches (610 mm) with a maximum supported area of 4 square feet (0.372 m<sup>2</sup>).

**Exception:** Existing anchor ties for attaching brick veneer to brick backing may be acceptable, provided the ties are in good condition and conform to the following minimum size and material requirements.

Existing veneer anchor ties may be considered adequate if they are of corrugated galvanized iron strips not less than 1 inch (25 mm) in width, 8 inches (203 mm) in length and 1/8 inch (1.6 mm) in thickness, or the equivalent.

2. The location and condition of existing veneer anchor ties shall be verified as follows:
  - 2.1. An approved testing laboratory shall verify the location and spacing of the ties and shall submit a report to the building official for approval as part of the structural analysis.
  - 2.2. The veneer in a selected area shall be removed to expose a representative sample of ties (not less than four) for inspection by the building official.

**[BS] A113.8 Nonstructural masonry walls.** Unreinforced masonry walls that carry no design vertical or lateral loads and that are not required by the design to be part of the lateral force-resisting system shall be adequately anchored to new or existing supporting elements. The anchors and elements shall be designed for the out-of-plane forces specified in the building code. The height- or length-to-thickness ratio between such supporting elements for such walls shall not exceed nine.

**[BS] A113.9 Truss and beam supports.** Where trusses and beams other than rafters or joists are supported on masonry, independent secondary columns shall be installed to support vertical loads of the roof or floor members.

**Exception:** Secondary supports are not required where *SDI* is less than 0.3g.

**[BS] A113.10 Adjacent buildings.** Where elements of adjacent buildings do not have a separation of at least 5 inches (127 mm), the allowable height-to-thickness ratios for "all other buildings" per Table ~~A1-B~~ A110.2 shall be used in the direction of consideration.

## SECTION A114 WALLS OF UNBURNED CLAY, ADOBE OR STONE MASONRY

**[BS] A114.1 General.** Walls of unburned clay, adobe or stone masonry construction shall conform to the following:

1. Walls of unburned clay, adobe or stone masonry shall not exceed a height- or length-to-thickness ratio specified in Table ~~A1-G~~ A114.1.
2. Adobe may be allowed a maximum value of 9 pounds per square inch (62.1 kPa) for shear unless higher values are justified by test.
3. Mortar for repointing may be of the same soil composition and stabilization as the brick, in lieu of cement-mortar.

### NOTE to RCC

Table A114.1 is formerly Table A1-G

[BS] TABLE A114.1  
MAXIMUM HEIGHT-TO-THICKNESS RATIO FOR ADOBE OR STONE WALLS

|                     | <i>S<sub>D1</sub></i>       |                            |                    |
|---------------------|-----------------------------|----------------------------|--------------------|
|                     | $0.13g \leq S_{D1} < 0.25g$ | $0.25g \leq S_{D1} < 0.4g$ | $S_{D1} \geq 0.4g$ |
| One-story buildings | 12                          | 10                         | 8                  |
| Two-story buildings |                             |                            |                    |
| First story         | 14                          | 11                         | 9                  |
| Second story        | 12                          | 10                         | 8                  |





## CHAPTER A2

# EARTHQUAKE HAZARD REDUCTION IN EXISTING REINFORCED CONCRETE AND REINFORCED MASONRY WALL BUILDINGS WITH FLEXIBLE DIAPHRAGMS

### SECTION A201 PURPOSE

**[BS] A201.1 Purpose.** The purpose of this chapter is to promote public safety and welfare by reducing the risk of death or injury as a result of the effects of earthquakes on reinforced concrete and reinforced masonry wall buildings with flexible diaphragms. Based on past earthquakes, these buildings have been categorized as being potentially hazardous and prone to significant damage, including possible collapse in a moderate to major earthquake. The provisions of this chapter are minimum standards for structural seismic resistance established primarily to reduce the risk of life loss or injury on both subject and adjacent properties. These provisions will not necessarily prevent loss of life or injury, or prevent earthquake damage to an *existing building* that complies with these standards.

### SECTION A202 SCOPE

**[BS] A202.1 Scope.** The provisions of this chapter shall apply to wall anchorage systems that resist out-of-plane forces and to collectors in existing reinforced concrete or reinforced masonry buildings with flexible diaphragms. Wall anchorage systems that were designed and constructed in accordance with the 1997 *Uniform Building Code*, ~~1999 *BOCA National Building Code*, 1999 *Standard Building Code*~~ or the 2000 or subsequent editions of the *International Building Code* shall be deemed to comply with these provisions.

### SECTION A203 DEFINITIONS

**[BS] A203.1 Definitions.** For the purpose of this chapter, the applicable definitions in ~~Chapters 16, 19, 21, 22 and 23~~ of the *International Building Code* and the following shall apply:

**[BS] CONTINUITY CONNECTOR.** A component, typically a plate, rod, strap or hold-down, that ensures load path continuity along the full length of a crosstie or strut.

**[BS] CROSSTIE.** A member or group of members continuous across the main diaphragm that connects opposite wall lines and transfers out-of-plane wall anchorage forces into the diaphragm.

**[BS] FLEXIBLE DIAPHRAGM.** A roof or floor sheathed with plywood, wood decking (1-by or 2-by) or metal deck without a concrete topping slab.

**[BS] STRUT.** A member or group of members continuous across a subdiaphragm that transfers out-of-plane wall anchorage forces into the subdiaphragm.

**[BS] WALL ANCHORAGE SYSTEM.** The components comprising a complete load path for out-of-plane wall forces from the wall to the main diaphragm, typically including anchors embedded in or fastened to the wall; rods, straps, plates, hold-downs or other hardware; subdiaphragms and their chords; crossties; struts; and continuity connectors.

**[BS] WALL SEGMENT.** Any length of concrete wall with continuous horizontal reinforcing and not interrupted or intersected by a pilaster or vertical construction joint, or any length of reinforced masonry wall with continuous horizontal reinforcing and not interrupted or intersected by a pilaster or vertical control joint.

### SECTION A204 SYMBOLS AND NOTATIONS

**[BS] A204.1 General.** For the purpose of this chapter, the applicable symbols and notations in the *International Building Code* shall apply.

### SECTION A205 GENERAL REQUIREMENTS

**[BS] A205.1 General.** The seismic-resisting elements specified in this chapter shall comply with applicable provisions of Section 1613 of the *International Building Code* and Chapter 12 of ASCE 7, except as modified herein.

~~[BS] A205.2 Alterations and repairs.~~ Alterations and repairs required to meet the provisions of this chapter shall comply with applicable structural requirements of the building code unless specifically modified in this chapter.

[BS] **A205.3 A205.2 Requirements for plans.** The plans shall accurately reflect the results of the engineering investigation and design and shall show all pertinent dimensions and sizes for plan review and construction. The following shall be provided:

1. Floor plans and roof plans shall show existing framing construction, diaphragm construction, proposed wall anchors, crossties and collectors. Existing nailing, anchors, crossties and collectors shall be shown on the plans if they are considered part of the lateral force-resisting systems.
2. Typical wall panel details and sections with panel thickness, height, pilasters and location of anchors shall be provided.
3. Details shall include existing and new anchors and the method of developing anchor forces into the diaphragm framing, existing and new crossties, and existing and new or improved support of roof and floor girders at pilasters or walls.
4. The basis for design and the building code used for the design shall be stated on the plans.

[BS] ~~A205.4 A205.3 Structural observation, testing and inspection.~~ Structural observation, in accordance with Section ~~1709~~ 1704.6 of the *International Building Code* ~~shall be required for all structures in which seismic retrofit is being performed in accordance with this chapter. is required, regardless of seismic design category, height or other conditions.~~ Structural observation shall include visual observation of work for conformance to the *approved* construction documents and confirmation of existing conditions assumed during design.

~~Structural testing and inspection for new construction materials shall be in accordance with the building code, except as modified by this chapter.~~

**A205.3.1 Additional special inspection.** In addition to the requirements of Section 1705.13 of the *International Building Code*, special inspection shall be required for:

1. Installation of anchors into existing concrete or masonry walls to form part of a wall anchorage system.
2. Fastening of new or existing steel deck forming part of a wall anchorage system.
3. Installation of continuity connectors along the length of crossties, to ensure compliance with Section A206.2. This inspection may be periodic special inspection.

**A205.3.2 Testing to establish adequacy of existing wall anchors.** Testing shall show that the existing anchors can sustain a test load of 1.5 times the design tension load without noticeable deformation or damage to the anchor, to the masonry or concrete element, or to any part of the existing load path between the anchor and new retrofit components. Three anchors of each existing detail type shall be tested, and all three shall satisfy the requirement. Prior to testing, the design professional shall submit a test plan for *code official* approval identifying the expected locations of the existing anchors in question, the locations of the proposed tests, and the test procedure and criteria. After testing, the design professional shall submit a report of the satisfactory testing showing the test results, the design strengths derived from them, and the size and spacing as confirmed by investigation.

**A205.4 Testing and Inspection.** Structural testing and inspection for new construction materials, submittals, reports and certificates of compliance shall be in accordance with Sections 1704 and 1705 of the *International Building Code*. Work done to comply with this chapter shall not be eligible for Exception 1 to Section 1704.2 of the *International Building Code* or Exception 2 to Section 1705.13 of the *International Building Code*.

## SECTION A206 ANALYSIS AND DESIGN

[BS] **A206.1 Reinforced concrete and reinforced masonry wall anchorage.** Concrete and masonry walls shall be anchored to all floors and roofs that provide lateral support for the wall. ~~The anchorage shall provide a positive direct connection between the wall and floor or roof construction capable of resisting 75 percent of the horizontal forces specified in Section 1613 of the *International Building Code* in accordance with Section 12.11.2 of ASCE 7. The anchorage shall provide a direct connection capable of resisting 75 percent of the forces specified in Section 12.11.2.1 of ASCE 7.~~

### Exceptions:

1. Existing walls need not be evaluated or retrofitted for bending between anchors.
2. Work required by this chapter need not consider shrinkage, thermal changes or differential settlement.

**A206.1.1 Seismicity parameters, site class and geologic hazards.** For any site designated as Site Class E, the value of  $F_a$  shall be taken as 1.2. Site-specific procedures are not required for compliance with this chapter. Mitigation of existing geologic site hazards such as liquefiable soil, fault rupture or landslide is not required for compliance with this chapter.

[BS] **A206.2 Special requirements for wall anchorage systems.** ~~The steel elements of the wall anchorage system shall be designed in accordance with the building code without the use of the 1.33 short duration allowable stress increase when using allowable stress design.~~

Wall anchors shall be provided to resist out of plane forces, independent of existing shear anchors.

**Exception:** Existing cast in place shear anchors are allowed to be used as wall anchors if the tie element can be readily attached to the anchors, and if the engineer or architect can establish tension values for the existing anchors through the use of approved as built plans or testing and through analysis showing that the bolts are capable of resisting the total shear load (including dead load) while being acted upon by the maximum tension force due to an earthquake. Criteria for analysis and testing shall be determined by the building official.

Expansion anchors are only allowed with special inspection and approved testing for seismic loading.

Attaching the edge of plywood sheathing to steel ledgers is not considered compliant with the positive anchoring requirements of this chapter. Attaching the edge of steel decks to steel ledgers is not considered as providing the positive anchorage of this chapter unless testing and/or analysis are performed to establish shear values for the attachment perpendicular to the edge of the deck. Where steel decking is used as a wall anchor system, the existing connections shall be subject to field verification and the new connections shall be subject to special inspection.

The wall anchorage system shall comply with the requirements of this section and Section 12.11.2.2 of ASCE 7.

The maximum spacing between wall anchors shall be 8 feet (2438 mm), and each wall segment shall have at least two wall anchors.

The wall anchorage system, excluding subdiaphragms and existing roof or floor framing members, shall be designed and installed to limit the relative movement between the wall and the diaphragm to no more than  $\frac{1}{8}$  inch before engagement of the anchors. Wall anchors shall be provided to resist out-of-plane forces, independent of existing shear anchors.

Where new members are added as crossties, they shall be spaced no more than 24 feet (7315 mm) apart. Where existing girders are used as crossties, their actual spacing shall be deemed adequate even where the spacing exceeds 24 feet (7315 mm), as long as the girders are provided with continuity connectors as required.

Wall anchorage shall not be provided by fastening the edge of plywood sheathing to steel ledgers. Wall anchorage shall not be provided solely by fastening the edge of steel decking to steel ledgers unless analysis demonstrates acceptable capacity. The existing connections shall be subject to field verification and the new connections shall be subject to special inspection.

New wall anchors shall be provided to resist the full wall anchorage design force independent of existing shear or tension anchors.

**Exception:** Existing cast-in-place anchors shall be permitted as part of the wall anchorage system if the tie element can be readily attached to the anchors, and if the anchors are capable of resisting the total vertical and lateral shear load (including dead load) while being acted on by the maximum wall anchorage tension force caused by an earthquake. Acceptable tension values for the existing anchors shall be established by testing in accordance with Section A205.4.

**[BS] A206.3 Development of anchor loads into the diaphragm.** Development of anchor loads into roof and floor diaphragms shall comply with Section I613 of the *International Building Code* using horizontal forces that are 75 percent of those used for new construction.

**Exception:** If continuously tied girders are present, the maximum spacing of the continuity ties is the greater of the girder spacing or 24 feet (7315 mm).

In wood diaphragms, anchorage shall not be accomplished by use of toenails or nails subject to withdrawal. Wood ledgers, top plates or framing shall not be used in cross grain bending or cross grain tension. The continuous ties required in Section I613 of the *International Building Code* shall be in addition to the diaphragm sheathing.

Lengths of development of anchor loads in wood diaphragms shall be based on existing field nailing of the sheath-

~~ing unless existing edge nailing is positively identified on the original construction plans or at the site.~~

Development of the required anchorage forces into roof and floor diaphragms shall comply with the requirements of this section and Section 12.11.2.2 of ASCE 7.

Lengths of development of anchor loads in wood diaphragms shall be based on existing field nailing of the sheathing unless existing edge nailing is positively identified on the original construction plans or at the site.

**[BS] A206.4 Anchorage at pilasters.**

~~Anchorage at pilasters shall be designed for the tributary wall anchoring load per Section A206.1, considering the wall as a two-way slab. The edges of the two-way slab shall be considered fixed when there is continuity at pilasters and shall be considered pinned at roof and floor. The pilasters or the walls immediately adjacent to the pilasters shall be anchored directly to the roof framing such that the existing vertical anchor bolts at the top of the pilasters are bypassed without permitting tension or shear failure at the top of the pilasters.~~

Where pilasters are present, the wall anchorage system shall comply with the requirements of this section and Section 12.11.2.2.7 of ASCE 7. The pilasters or the walls immediately adjacent to the pilasters shall be anchored directly to the roof framing such that the existing vertical anchor bolts at the top of the pilasters are bypassed without permitting tension or shear failure at the top of the pilasters.

**Exception:** If existing vertical anchor bolts at the top of the pilasters are used for the anchorage, additional exterior confinement shall be provided as required to resist the total anchorage force.

~~The minimum anchorage force at a floor or roof between the pilasters shall be that specified in Section A206.1.~~

~~**[BS] A206.5 Symmetry.** Symmetry of wall anchorage and continuity connectors about the minor axis of the framing member is required.~~

~~**Exception:** Eccentricity may be allowed when it can be shown that all components of forces are positively resisted. The resistance must be supported by calculations or tests.~~

**[BS] A206.6 A206.5 Combination of anchor types.** New anchors used in combination on a single framing member shall be of compatible behavior and stiffness. ■

**[BS] A206.7 A206.6 Anchorage at interior walls.** Existing interior reinforced concrete or reinforced masonry walls that extend to the floor above or to the roof diaphragm shall be anchored for out-of-plane forces per Sections A206.1 and A206.3. Walls extending through the roof diaphragm shall be anchored for out-of-plane forces on both sides, and continuity ties shall be spliced across or continuous through the interior wall to provide diaphragm continuity.

**[BS] A206.8 A206.7 Collectors.** Collectors designed in accordance with this section shall be provided at reentrant corners and at interior shear walls. Existing or new collectors shall have the capacity to develop into the diaphragm a force equal to the lesser of the rocking or shear capacity of the reentrant wall or the tributary shear based on 75 percent of the diaphragm design forces specified in Section 12.10 of ASCE 7. The capacity of the collector need not exceed the capacity of the diaphragm to deliver loads to the collector. A connection shall be provided from the collector to the reentrant wall to transfer the full collector internal force. If a truss or beam other than a rafter or purlin is supported by the reentrant wall or by a column integral with the reentrant wall, then an independent secondary column is required to support the roof or floor members whenever rocking or shear capacity of the reentrant wall is less than the tributary shear.

**[BS] A206.9 A206.8 Mezzanines.** Existing mezzanines relying on reinforced concrete or reinforced masonry walls for vertical or lateral support shall be anchored to the walls for the tributary mezzanine load. Walls depending on the mezzanine for lateral support shall be anchored per Sections A206.1, A206.2 and A206.3.

**Exception:** Existing mezzanines that have independent lateral and vertical support need not be anchored to the walls.

## SECTION A207 MATERIALS OF CONSTRUCTION

**[BS] A207.1 Materials.** Materials permitted by the building code, including their appropriate strength or allowable stresses, shall be used to meet the requirements of this chapter.

## CHAPTER A3

# PRESCRIPTIVE PROVISIONS FOR SEISMIC STRENGTHENING OF CRIPPLE WALLS AND SILL PLATE ANCHORAGE OF LIGHT, WOOD-FRAME RESIDENTIAL BUILDINGS

### SECTION A301 GENERAL

**[BS] A301.1 Purpose.** The provisions of this chapter are intended to promote public safety and welfare by reducing the risk of earthquake-induced damage to existing wood-frame residential buildings. The requirements contained in this chapter are prescriptive minimum standards intended to improve the seismic performance of residential buildings; however, they will not necessarily prevent earthquake damage.

This chapter sets standards for strengthening that may be *approved* by the *code official* without requiring plans or calculations prepared by a registered design professional. The provisions of this chapter are not intended to prevent the use of any material or method of construction not prescribed herein. The *code official* may require that construction documents for strengthening using alternative materials or methods be prepared by a registered design professional.

**[BS] A301.2 Scope.** The provisions of this chapter apply to residential buildings of light-frame wood construction containing one or more of the structural weaknesses specified in Section A303.

**Exception:** The provisions of this chapter do not apply to the buildings, or elements thereof, listed as follows. These buildings or elements require analysis by a registered design professional in accordance with Section A301.3 to determine appropriate strengthening:

- ~~1.~~ Group R-1, ~~R-2~~ or ~~R-4~~ occupancies with more than four dwelling units.
2. Group R with more than four dwelling units.
- ~~2.3.~~ Buildings with a lateral force-resisting system using poles or columns embedded in the ground.
- ~~3.4.~~ Cripple walls that exceed 4 feet (1219 mm) in height.
- ~~4.5.~~ Buildings exceeding three stories in height and any three-story building with cripple wall studs exceeding 14 inches (356 mm) in height.
- ~~5.6.~~ Buildings where the *code official* determines that conditions exist that are beyond the scope of the prescriptive requirements of this chapter.
- ~~6.7.~~ Buildings or portions thereof constructed on concrete slabs on grade.

**[BS] A301.3 Alternative design procedures.** The details and prescriptive provisions herein are not intended to be the only acceptable strengthening methods permitted. Alternative details and methods shall be permitted to be used where *approved* by the *code official*. Approval of alternatives shall be based on a demonstration that the method or material used is at least equivalent in terms of strength, deflection and capacity to that provided by the prescriptive methods and materials.

Where analysis by a registered design professional is required, such analysis shall be in accordance with all requirements of the building code, except that the seismic forces may be taken as 75 percent of those specified in the *International Building Code*.

### SECTION A302 DEFINITIONS

**[BS] A302.1 Definitions.** For the purpose of this chapter, in addition to the applicable definitions in the building code, certain additional terms are defined as follows:

**[BS] ADHESIVE ANCHOR.** An assembly consisting of a threaded rod, washer, nut, and chemical adhesive approved by the *code official* for installation in existing concrete or masonry.

**[BS] CRIPPLE WALL.** A wood-frame stud wall extending from the top of the foundation to the underside of the lowest floor framing.

**[BS] EXPANSION ANCHOR.** An *approved* post-installed anchor, inserted into a predrilled hole in existing concrete or masonry, that transfers loads to or from the concrete or masonry by direct bearing or friction or both.

**[BS] PERIMETER FOUNDATION.** A foundation system that is located under the exterior walls of a building.

**[BS] SNUGTIGHT.** As tight as an individual can torque a nut on a bolt by hand, using a wrench with a 10-inch-long (254 mm) handle, and the point at which the full surface of the plate washer is contacting the wood member and slightly indenting the wood surface.

**[BS] WOOD STRUCTURAL PANEL.** A panel manufactured from veneers, wood strands or wafers or a combination of veneer and wood strands or wafers bonded together with waterproof synthetic resins or other suitable bonding systems. Examples of wood structural panels are:

**Composite panels.** A wood structural panel that is comprised of wood veneer and reconstituted wood-based material and bonded together with waterproof adhesive.

**Oriented strand board (OSB).** A mat-formed wood structural panel comprised of thin rectangular wood strands arranged in cross-aligned layers with surface layers normally arranged in the long panel direction and bonded with waterproof adhesive.

**Plywood.** A wood structural panel comprised of plies of wood veneer arranged in cross-aligned layers. The plies are bonded with waterproof adhesive that cures on application of heat and pressure.

## SECTION A303 STRUCTURAL WEAKNESSES

**[BS] A303.1 General.** For the purposes of this chapter, any of the following conditions shall be deemed a structural weakness:

1. Sill plates or floor framing that are supported directly on the ground without a foundation system that conforms to the building code.
2. A perimeter foundation system that is constructed only of wood posts supported on isolated pad footings.
3. Perimeter foundation systems that are not continuous.

### Exceptions:

1. Existing single-story exterior walls not exceeding 10 feet (3048 mm) in length, forming an extension of floor area beyond the line of an existing continuous perimeter foundation.
2. Porches, storage rooms and similar spaces not containing fuel-burning appliances.
4. A perimeter foundation system that is constructed of unreinforced masonry or stone.
5. Sill plates that are not connected to the foundation or that are connected with less than what is required by the building code.

**Exception:** Where *approved* by the *code official*, connections of a sill plate to the foundation made with other than sill bolts shall be accepted if the capacity of the connection is equivalent to that required by the building code.

6. Cripple walls that are not braced in accordance with the requirements of Section ~~A304.4 and Table A3-A~~, A304.4 and Table A304.3.1, or cripple walls not braced with diagonal sheathing or wood structural panels in accordance with the building code.

## SECTION A304 STRENGTHENING REQUIREMENTS

**[BS] A304.1 General.**

**[BS] A304.1.1 Scope.** The structural weaknesses noted in Section A303 shall be strengthened in accordance with the requirements of this section. Strengthening work may include both new construction and *alteration* of existing construction. Except as provided herein, all strengthening work and materials shall comply with the applicable provisions of the *International Building Code*.

**[BS] A304.1.2 Condition of existing wood materials.** Existing wood materials that will be a part of the strengthening work (such as sills, studs and sheathing) shall be in a sound condition and free from defects that substantially reduce the capacity of the member. Any wood material found to contain fungus infection shall be removed and replaced with new material. Any wood material found to be infested with insects or to have been infested with insects shall be strengthened or replaced with new materials to provide a net dimension of sound wood equal to or greater than its undamaged original dimension.

**[BS] A304.1.3 Floor joists not parallel to foundations.** Floor joists framed perpendicular or at an angle to perimeter foundations shall be restrained either by an existing nominal 2-inch-wide (51 mm) continuous rim joist or by a nominal 2-inch-wide (51 mm) full-depth block between alternate joists in one- and two-story buildings, and between each joist in three-story buildings. Existing blocking for multiple-story buildings must occur at each joist space above a braced cripple wall panel.

Existing connections at the top and bottom edges of an existing rim joist or blocking need not be verified in one story buildings. In multiple-story buildings, the existing top edge connection need not be verified; however, the bottom edge connection to either the foundation sill plate or the top plate of a cripple wall shall be verified. The minimum existing bottom edge connection shall consist of 8d toenails spaced 6 inches (152 mm) apart for a continuous rim joist, or three 8d toenails per block. Where this minimum bottom edge-connection is not present or cannot be verified, a supplemental connection installed as shown in Figure ~~A3-8A or A3-8C~~ shall be provided. A304.1.3 or A304.1.4(2) shall be provided.

Where an existing continuous rim joist or the minimum existing blocking does not occur, new <sup>3</sup>/<sub>4</sub>-inch (19.1 mm) or <sup>23</sup>/<sub>32</sub>-inch (18 mm) wood structural panel blocking installed tightly between floor joists and nailed as shown in Figure A304.1.4(3) shall be provided at the inside face of the cripple wall. In lieu of wood structural panel blocking, tight fitting, full-depth 2-inch (51 mm) blocking may be used. New blocking may be omitted where it will interfere with vents or plumbing that penetrates the wall.

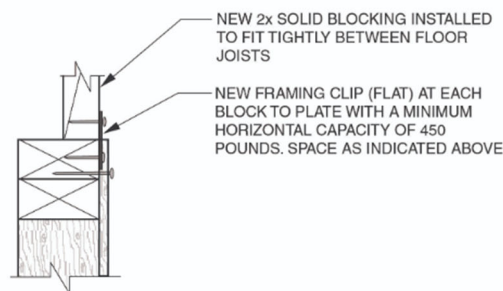
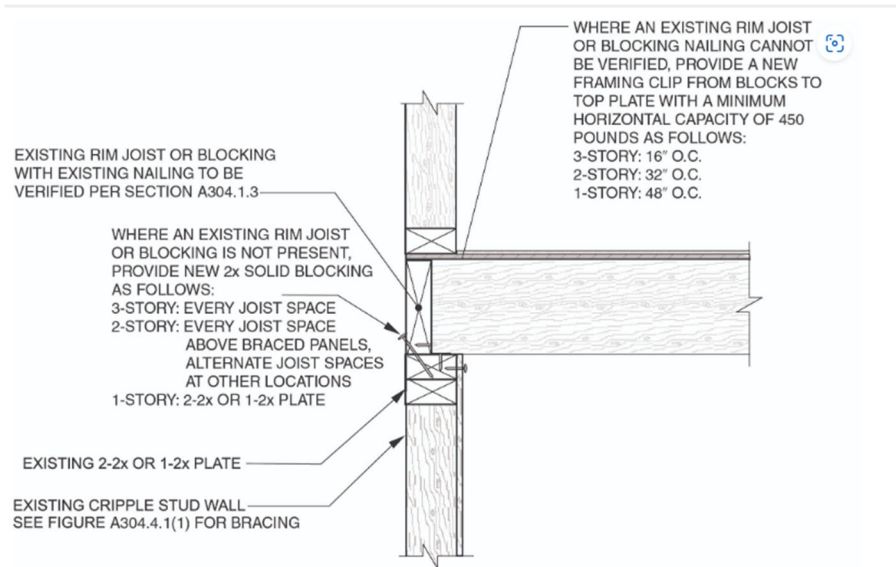

**ALTERNATE CONNECTION FOR FLUSH CONNECTION**

For SI: 1 inch = 25.4 mm, 1 pound = 4.4 N.

**NOTE:** See manufacturing instructions for nail sizes associated with metal framing clips.

[BS] FIGURE A304.1.3

TYPICAL FLOOR TO CRIPPLE WALL CONNECTION (FLOOR JOISTS NOT PARALLEL TO FOUNDATIONS)

**Note to RCC**

Figure A304.1.3 is formerly A3-8B

**[BS] A304.1.4 Floor joists parallel to foundations.** Where existing floor joists are parallel to the perimeter foundations, the end joist shall be located over the foundation and, except for required ventilation openings, shall be continuous and in continuous contact with the foundation sill plate or the top plate of the cripple wall. Existing connections at the top and bottom edges of the end joist need not be verified in one-story buildings. In multiple-story buildings, the existing top edge connection of the end joist need not be verified; however, the bottom edge connection to either the foundation sill plate or the top plate of a cripple wall shall be verified. The minimum bottom edge connection shall be 8d toenails spaced 6 inches (152 mm) apart. If this minimum bottom edge connection is not present or cannot be verified, a supplemental connection installed as shown in Figure ~~A3-8B, A3-8C or A3-9~~ A304.1.4(1), A304.1.4(2) or A304.1.4(3) shall be provided.

For SI: 1 inch = 25.4 mm, 1 pound = 4.4 N.

For SI: 1 inch = 25.4 mm.



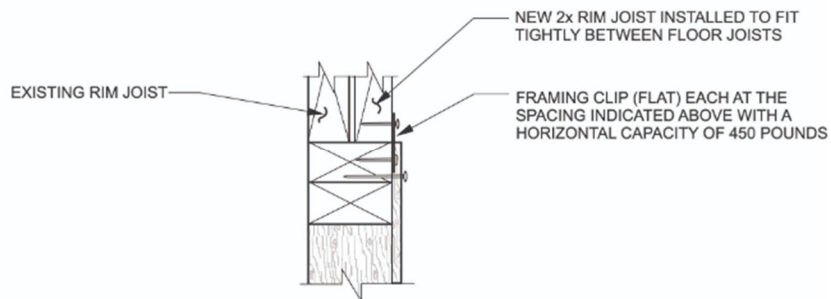
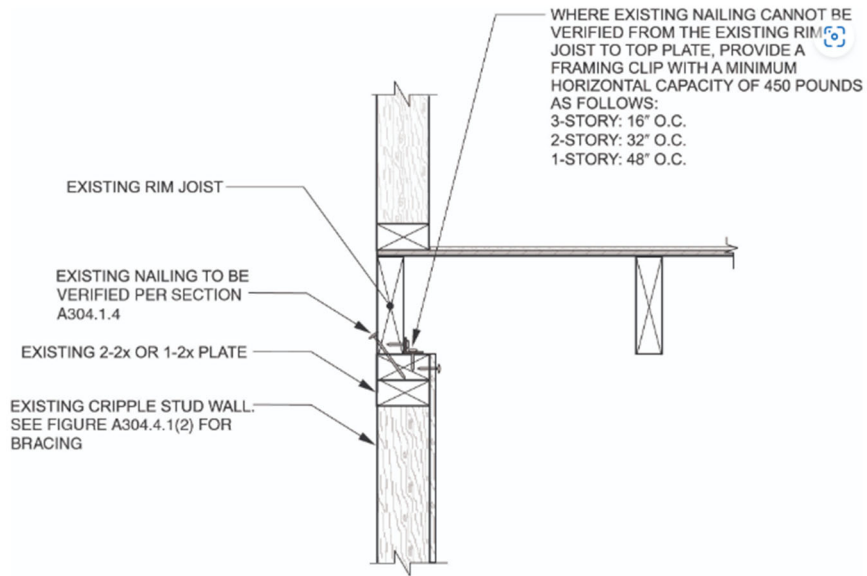

**ALTERNATE CONNECTION FOR FLUSH CONNECTION**

For SI: 1 inch = 25.4 mm, 1 pound = 4.4 N.

**NOTE:** See manufacturing instructions for nail sizes associated with metal framing clips.

[BS] **FIGURE A304.1.4(1)**  
**TYPICAL FLOOR TO CRIPPLE WALL CONNECTION (FLOOR JOISTS PARALLEL TO FOUNDATIONS)**

Note to RCC

Figure A304.1.4(1) is formerly A3-8A



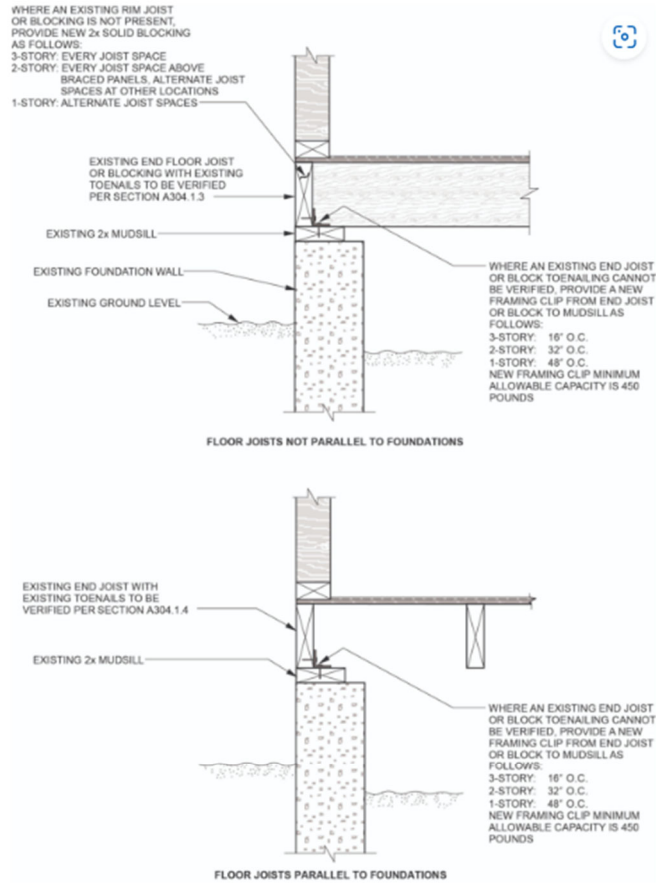

For SI: 1 inch = 25.4 mm.

**NOTES:**

1. See Section A304.3 for sill plate anchorage.
2. See manufacturing instructions for nail sizes associated with metal framing clips.

**[Bs] FIGURE A304.1.4(2)  
TYPICAL FLOOR TO MUDSILL CONNECTIONS**

Note to RCC

Figure A304.1.4(2) is formerly A3-8CA

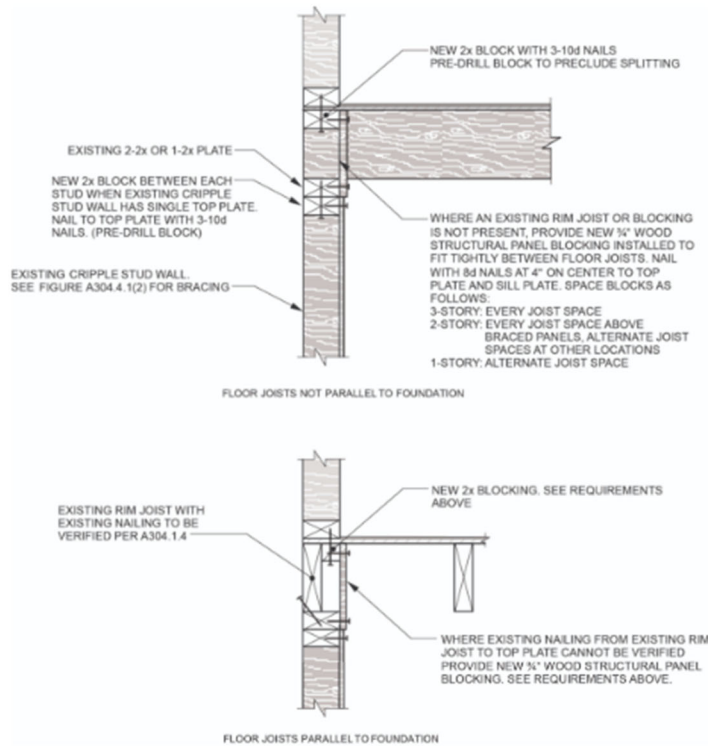

For SI: 1 inch = 25.4 mm, 1 pound = 4.4 N.

**NOTE:** See Section A304.4 for cripple wall bracing.

[BS] FIGURE A304.1.4(3)  
ALTERNATIVE FLOOR FRAMING TO CRIPPLE WALL  
CONNECTION

**Note to RCC**

Figure A304.1.4(3) is formerly A3-9

[BS] A304.2 Foundations.

[BS] A304.2.1 **New perimeter foundations.** New perimeter foundations shall be provided for structures with the structural weaknesses noted in Items 1 and 2 of Section A303. Soil investigations or geotechnical studies are not required for this work unless the building is located in a special study zone as designated by the *code official* or other authority having jurisdiction.

[BS] A304.2.2 **Evaluation of existing foundations.** Partial perimeter foundations or unreinforced masonry foundations shall be evaluated by a registered design professional for the force levels specified in Section A301.3. Test reports or other substantiating data to determine existing foundation material strengths shall be submitted to the *code official*. Where *approved* by the *code official*, these existing foundation systems shall be strengthened in accordance with the recommendations included with the evaluation in lieu of being replaced.

**Exception:** In lieu of testing existing foundations to determine material strengths, and where *approved* by the *code official*, a new nonperimeter foundation system designed for the forces specified in Section A301.3 shall be used to resist lateral forces from perimeter walls. A registered design professional shall confirm the ability of the existing diaphragm to transfer seismic forces to the new nonperimeter foundations.

[BS] A304.2.3 **Details for new perimeter foundations.** All new perimeter foundations shall be continuous and constructed according to ~~either Figure A3-1 or A3-2.~~ Figure A304.2.3(1) and Table A304.2.3(1) or Figure A304.2.3(2) and Table A304.2.3(2). ~~New~~ All new construction materials shall comply with the requirements of building code. Where *approved* by the *code official*, the existing clearance between existing floor joists or girders and existing grade below the floor need not comply with the building code.

**Exception:** Where designed by a registered design professional and *approved* by the *code official*, partial perimeter foundations shall be used in lieu of a continuous perimeter foundation.

[BS] ~~Figure A3-4~~ TABLE A304.2.3(1)  
NEW REINFORCED CONCRETE FOUNDATION SYSTEM

| MINIMUM FOUNDATION DIMENSIONS |           |          |                      |           |             | MINIMUM FOUNDATION REINFORCING |                                   |
|-------------------------------|-----------|----------|----------------------|-----------|-------------|--------------------------------|-----------------------------------|
| NUMBER OF STORIES             | W         | F        | D <sup>a, b, c</sup> | T         | H           | VERTICAL REINFORCING           |                                   |
|                               |           |          |                      |           |             | Single-pour wall and footing   | Footing placed separate from wall |
| 1                             | 12 inches | 6 inches | 12 inches            | 6 inches  | ≤ 24 inches | #4 @ 48 inches on center       | #4 @ 32 inches on center          |
| 2                             | 15 inches | 7 inches | 18 inches            | 8 inches  | ≥ 36 inches | #4 @ 48 inches on center       | #4 @ 32 inches on center          |
| 3                             | 18 inches | 8 inches | 24 inches            | 10 inches | ≥ 36 inches | #4 @ 48 inches on center       | #4 @ 18 inches on center          |

For SI: 1 inch = 25.4 mm.

- Where frost conditions occur, the minimum depth shall extend below the frost line.
- The ground surface along the interior side of the foundation may be excavated to the elevation of the top of the footing.
- Where the soil is designated as expansive, the foundation depth and reinforcement shall be approved by the code official.

**[BS] Figure A3-2 TABLE A304.2.3(2)  
NEW MASONRY CONCRETE FOUNDATION**

| MINIMUM FOUNDATION DIMENSIONS |           |          |                      |           |             | MINIMUM FOUNDATION REINFORCING |                                   |
|-------------------------------|-----------|----------|----------------------|-----------|-------------|--------------------------------|-----------------------------------|
| NUMBER OF STORIES             | W         | F        | D <sup>a, b, c</sup> | T         | H           | VERTICAL REINFORCING           | HORIZONTAL REINFORCING            |
|                               |           |          |                      |           |             |                                |                                   |
| 1                             | 12 inches | 6 inches | 12 inches            | 6 inches  | ≤ 24 inches | #4 @ 24 inches on center       | #4 continuous at top of stem wall |
| 2                             | 15 inches | 7 inches | 18 inches            | 8 inches  | ≥ 24 inches | #4 @ 24 inches on center       | #4 @ 16 inches on center          |
| 3                             | 18 inches | 8 inches | 24 inches            | 10 inches | ≥ 36 inches | #4 @ 24 inches on center       | #4 @ 16 inches on center          |

For SI: 1 inch = 25.4 mm.

- Where frost conditions occur, the minimum depth shall extend below the frost line.
- The ground surface along the interior side of the foundation may be excavated to the elevation of the top of the footing.
- Where the soil is designated as expansive, the foundation depth and reinforcement shall be approved by the code official.

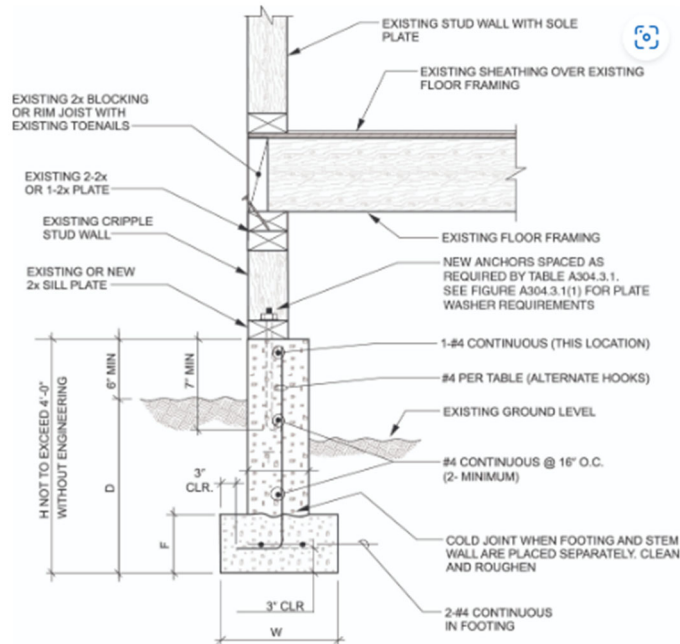

For SI: 1 inch = 25.4 mm, 1 foot = 304.8 mm.

[BS] FIGURE A304.2.3(1)

**NEW REINFORCED CONCRETE FOUNDATION SYSTEM**

**Note to RCC**

Figure A304.2.3(1) is formerly A3-1

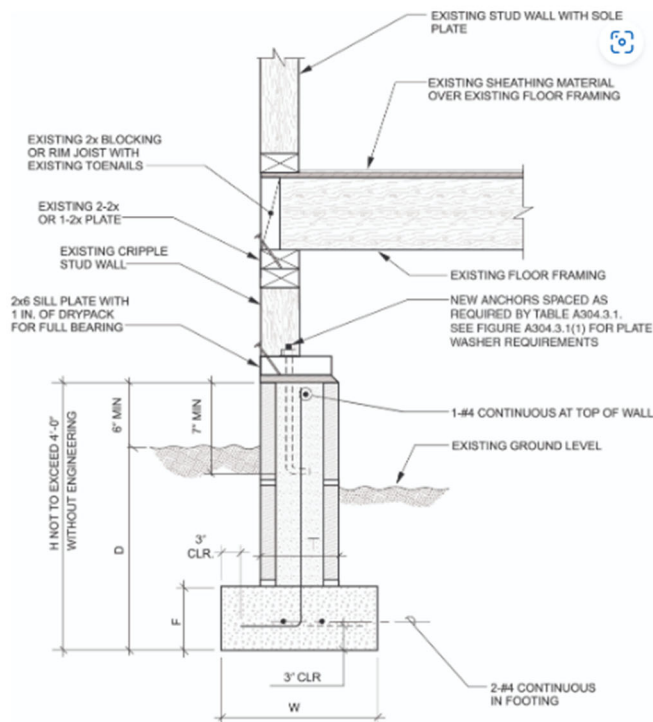

For SI: 1 inch = 25.4 mm, 1 foot = 304.8 mm.

[BS] FIGURE A304.2.3(2)

**NEW MASONRY CONCRETE FOUNDATION**

**Note to RCC**

**Figure A304.2.3(2) is formerly A3-2**

**[BS] A304.2.4 New concrete foundations.** New concrete foundations shall have a minimum compressive strength of 2,500 pounds per square inch (17.24 MPa) at 28 days.

**[BS] A304.2.5 New hollow-unit masonry foundations.** New hollow-unit masonry foundations shall be solidly grouted. The grout shall have minimum compressive strength of 2,000 pounds per square inch (13.79 MPa). Mortar shall be Type M or S.

**[BS] A304.2.6 New sill plates.** Where new sill plates are used in conjunction with new foundations, they shall be minimum two times nominal thickness and shall be preservative-treated wood or naturally durable wood permitted by the building code for similar applications, and shall be marked or branded by an *approved* agency. Fasteners in contact with preservative-treated wood shall be hot-dip galvanized or other material permitted by the building code for similar applications. Anchors, that attach a preservative-treated sill plate to the foundation, shall be permitted to be of mechanically deposited zinc-coated steel with coating weights in accordance with ASTM B695, Class 55 minimum. Metal framing anchors in contact with preservative-treated wood shall be galvanized in accordance with ASTM A653 with a G185 coating.

**[BS] A304.3 Foundation sill plate anchorage.**

**[BS] A304.3.1 Existing perimeter foundations.** Where the building has an existing continuous perimeter foundation, all perimeter wall sill plates shall be anchored to the foundation with adhesive anchors or expansion anchors in accordance with Table ~~A3-A~~ A304.3.1.

Anchors shall be installed in accordance with Figure ~~A3-A~~ A304.3.1(1), with the plate washer installed between the nut and the sill plate. The nut shall be tightened to a snug-tight condition after curing is complete for adhesive anchors and after expansion wedge engagement for expansion anchors. ~~All anchors~~ Anchors shall be installed in accordance with manufacturer's recommendations. Expansion anchors shall not be used where the installation causes surface cracking of the foundation wall at the locations of the anchor.

Where existing conditions prevent anchor installations through the top of the sill plate, this connection shall be made in accordance with Figure ~~A3-4A, A3-4B or A3-4C~~ A304.3.1(2), A304.3.1(3) or A304.3.1(4). ~~The spacing of these alternate connections shall comply with the maximum spacing requirements of Table A3-A. Expansion anchors shall not be used where the installation causes surface cracking of the foundation wall at the locations of the anchor. Alternative anchorage methods having a minimum shear capacity of 900 pounds (4003 N) per connection parallel to the wall shall be permitted. The spacing of these alternative connections shall comply with the maximum spacing requirements of Table A304.3.1 for 1/2-inch (12.7 mm) bolts.~~

**[BS] TABLE A3-A A304.3.1  
SILL PLATE ANCHORAGE AND CRIPPLE WALL BRACING**

| NUMBER OF STORIES ABOVE CRIPPLE WALLS | MINIMUM SILL PLATE CONNECTION AND MAXIMUM SPACING <sup>a, b, c</sup>  | AMOUNT OF BRACING FOR EACH WALL LINE <sup>d, e, f</sup>   |   |
|---------------------------------------|---|---|---|
|                                       |   | A Combination of Exterior Walls Finished with Portland Cement Plaster and Roofing Using Clay Tile or Concrete Tile Weighing More than 6 psf (287 N/m <sup>2</sup> ) | All Other Conditions  |
| One story                             | 1/2 inch spaced 6 feet, 0 inch center-to-center with washer plate   | Each end and not less than 50 percent of the wall length  | Each end and not less than 40 percent of the wall length              |
| Two stories                           | 1/2 inch spaced 4 feet, 0 inch center-to-center with washer plate; or 5/8 inch spaced 6 feet, 0 inch center-to-center with washer plate | Each end and not less than 70 percent of the wall length  | Each end and not less than 50 percent of the wall length              |
| Three stories                         | 5/8 inch spaced 4 feet, 0 inch center-to-center with washer plate   | 100 percent of the wall length <sup>g</sup>   | Each end and not less than 80 percent of the wall length <sup>g</sup> |

For SI: 1 inch = 25.4 mm, 1 foot = 304.8 mm, 1 pound per square foot = 47.88 N/m<sup>2</sup>.

a. Sill plate anchors shall be adhesive anchors or expansion anchors in accordance with Section A304.3.1.

b. All washer plates shall be 3 inches by 3 inches by 0.229 inch minimum. The hole in the plate washer is permitted to be diagonally slotted with a width of up to 3/16 inch larger than the bolt diameter and a slot length not to exceed 1 3/4 inches, provided that a standard cut washer is placed between the plate washer and the nut.

c. This table shall also be permitted for the spacing of the alternative connections specified in Section A304.3.1.

d. See Figure A304.4.2 for braced panel layout.

e. Braced panels at ends of walls shall be located as near to the end as possible.

f. All panels along a wall shall be nearly equal in length and shall be nearly equal in spacing along the length of the wall.

g. The minimum required underfloor ventilation openings are permitted in accordance with Section A304.4.4.

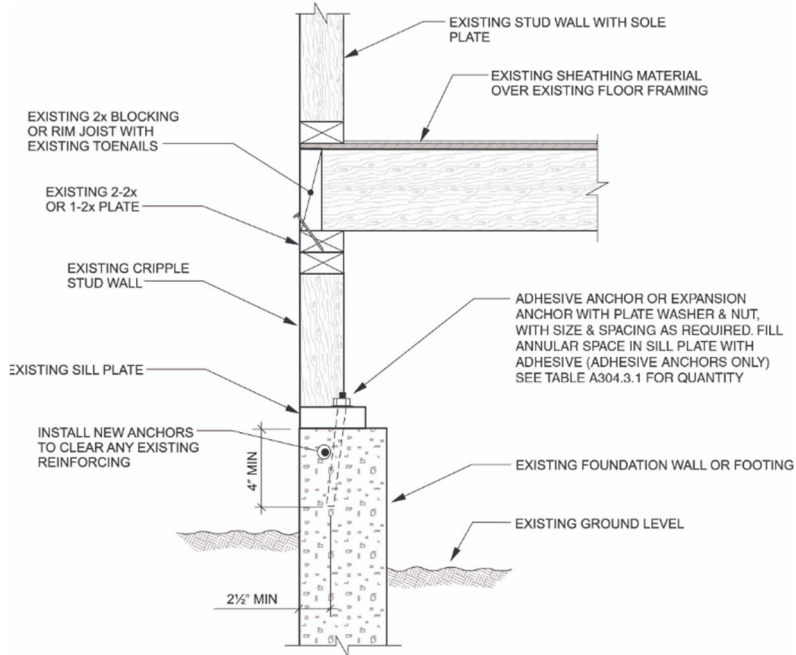

For SI: 1 inch = 25.4 mm.

- a. Plate washers shall comply with the following:
  - $\frac{1}{2}$ -inch anchor or bolt—3 inches  $\times$  3 inches  $\times$  0.229 inch minimum.
  - $\frac{5}{16}$ -inch anchor or bolt—3 inches  $\times$  3 inches  $\times$  0.229 inch minimum.
- A diagonal slot in the plate washer is permitted in accordance with Table A304.3.1, Note b.
- b. See Figure A304.4.1(1) or A304.4.1(2) for cripple wall bracing.

[BS] FIGURE A304.3.1(1) SILL PLATE BOLTING TO EXISTING FOUNDATION<sup>a, b</sup>

**Note to RCC**

Figure A304.3.1(1) is formerly A3-3

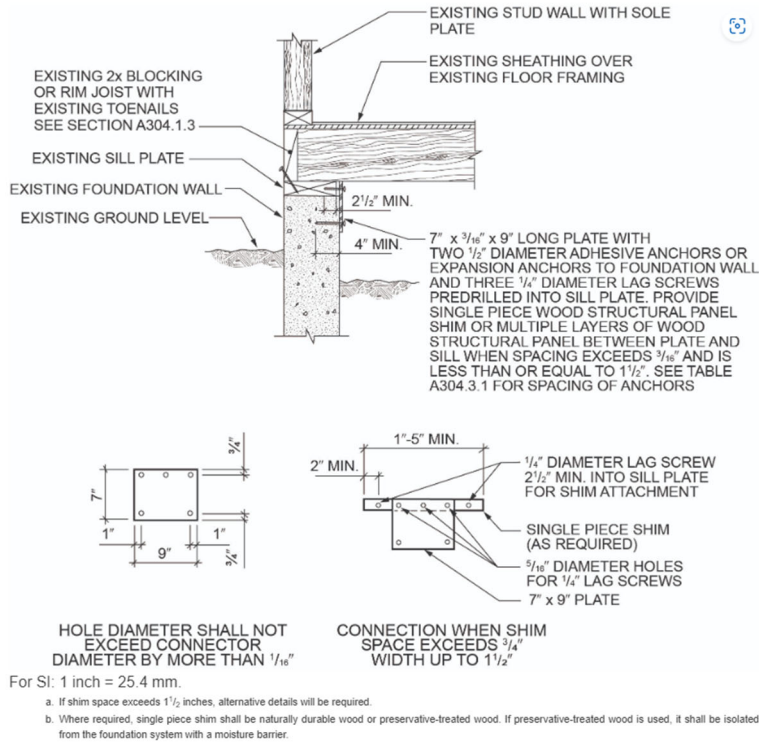

[Bs] FIGURE A304.3.1(2)  
 ALTERNATIVE SILL PLATE ANCHORING IN EXISTING FOUNDATION—WITHOUT CRIPPLE WALLS AND FLOOR FRAMING NOT PARALLEL TO FOUNDATIONS<sup>a, b</sup>

Note to RCC  
 Figure A304.3.1(2) is formerly 4B

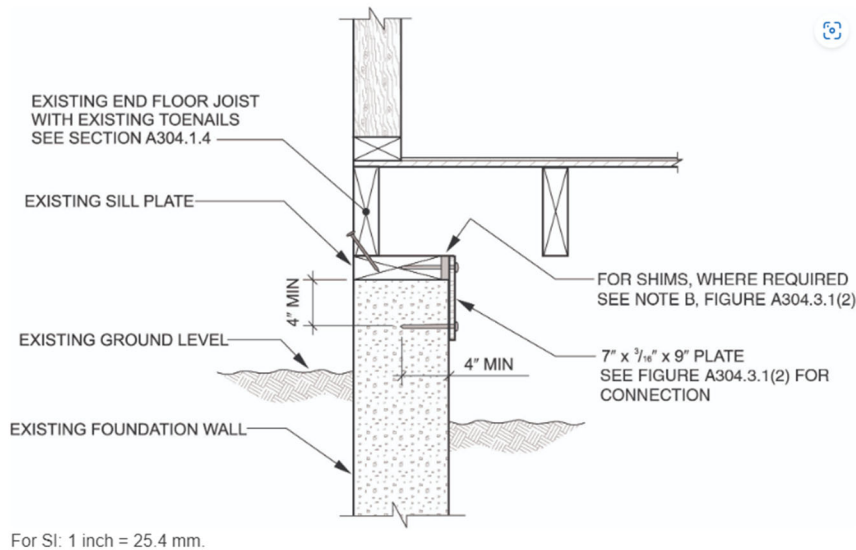

For SI: 1 inch = 25.4 mm.

[Bs] FIGURE A304.3.1(3)  
 ALTERNATIVE SILL PLATE ANCHOR TO EXISTING FOUNDATION WITHOUT CRIPPLE WALL AND FLOOR FRAMING PARALLEL TO FOUNDATIONS

Note to RCC  
 Figure A304.3.1(3) is formerly 4A



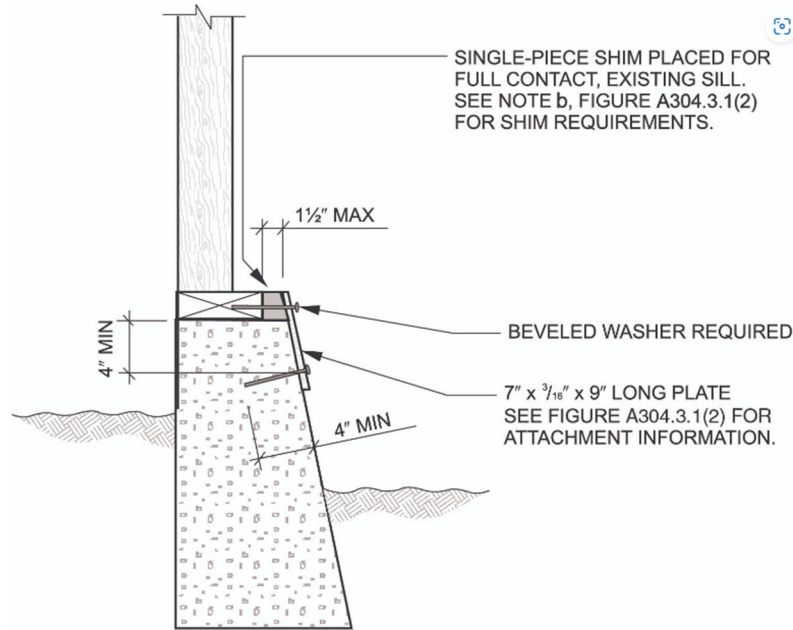

For SI: 1 inch = 25.4 mm.

[BS] FIGURE A304.3.1(4)

SILL PLATE ANCHORING TO EXISTING FOUNDATION—ALTERNATIVE CONNECTION FOR BATTERED FOOTING

**Note to RCC**

Figure A304.3.1(4) is formerly 4C

**[BS] A304.3.2 Placement of anchors.** Anchors shall be placed within 12 inches (305 mm), but not less than 9 inches (229 mm), from the ends of sill plates and shall be placed in the center of the stud space closest to the required spacing. New sill plates may be installed in pieces where necessary because of existing conditions. For lengths of sill plates 12 feet (3658 mm) or greater, anchors shall be spaced along the sill plate as specified in Table A3-A A304.3.1. For other lengths of sill plate, anchor placement shall be in accordance with Table A3-B A304.3.2.

**Exception:** Where physical obstructions such as fireplaces, plumbing or heating ducts interfere with the placement of an anchor, the anchor shall be placed as close to the obstruction as possible, but not less than 9 inches (229 mm) from the end of the plate. Center-to-center spacing of the anchors shall be reduced as necessary to provide the minimum total number of anchors required based on the full length of the wall. Center-to-center spacing shall be not less than 12 inches (305 mm).

**[BS] TABLE A3-B A304.3.2**  
SILL PLATE ANCHORAGE FOR VARIOUS LENGTHS OF SILL PLATE<sup>a, b</sup>

| NUMBER OF STORIES | LENGTHS OF SILL PLATE   |                               |                                  |
|-------------------|---|-------------------------------|----------------------------------|
|                   | Less than 12 feet to 6 feet   | Less than 6 feet to 30 inches | Less than 30 inches <sup>c</sup> |
| One story         | Three connections   | Two connections               | One connection                   |
| Two stories       | Four connections for 1/2-inch anchors or bolts or three connections for 5/8-inch anchors or bolts | Two connections               | One connection                   |
| Three stories     | Four connections  | Two connections               | One connection                   |

For SI: 1 inch = 25.4 mm, 1 foot = 304.8 mm.

a. Connections shall be either adhesive anchors or expansion anchors.

b. See Section A304.3.2 for minimum end distances.

c. Connections shall be placed as near to the center of the length of plate as possible.

**[BS] A304.3.3 New perimeter foundations.** Sill plates for new perimeter foundations shall be anchored in accordance with Table A3-A and as shown in Figure A3-1 or A3-2. A304.3.1 and Figure A304.2.3(1) and Table A304.2.3(1) or Figure A304.2.3(2) and

Table A304.2.3(2).

**[BS] A304.4 Cripple wall bracing.**

**[BS] A304.4.1 General.** Exterior cripple walls not exceeding 4 feet (1219 mm) in height shall be permitted to be specified by the prescriptive bracing method in Section A304.4. Cripple walls over 4 feet (1219 mm) in height require analysis by a registered design professional in accordance with Section A301.3.

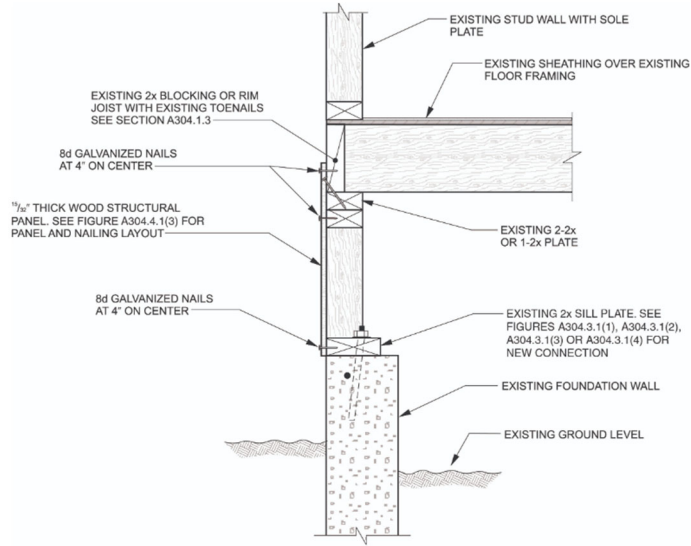

For SI: 1 inch = 25.4 mm. **NOTE:** See Figure A304.3.1(1) for sill plate anchoring.

[BS] FIGURE A304.4.1(1)  
CRIPPLE WALL BRACING WITH NEW WOOD STRUCTURAL PANEL ON EXTERIOR FACE OF CRIPPLE STUDS

**Note to RCC**

Figure A304.4.1(1) is formerly A3-5

For SI: 1 inch = 25.4 mm.

For SI: 1 inch = 25.4 mm.

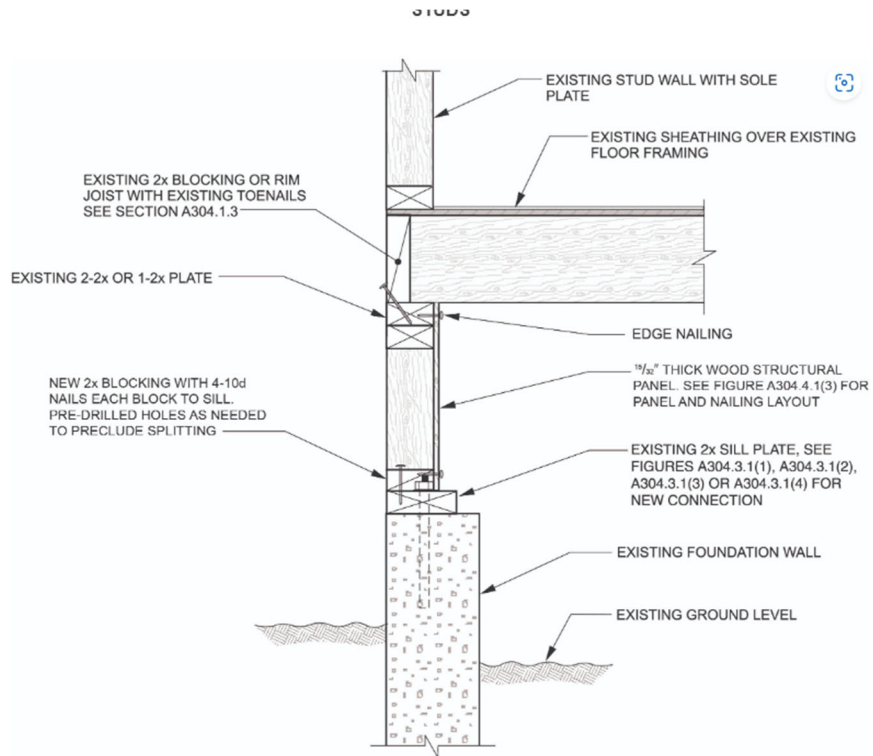

For SI: 1 inch = 25.4 mm.

[Bs] FIGURE A304.4.1(2)  
CRIPPLE WALL BRACING WITH WOOD STRUCTURAL PANEL ON INTERIOR FACE OF CRIPPLE STUDS

**Note to RCC**

Figure A304.4.4(2) is formerly A3-6

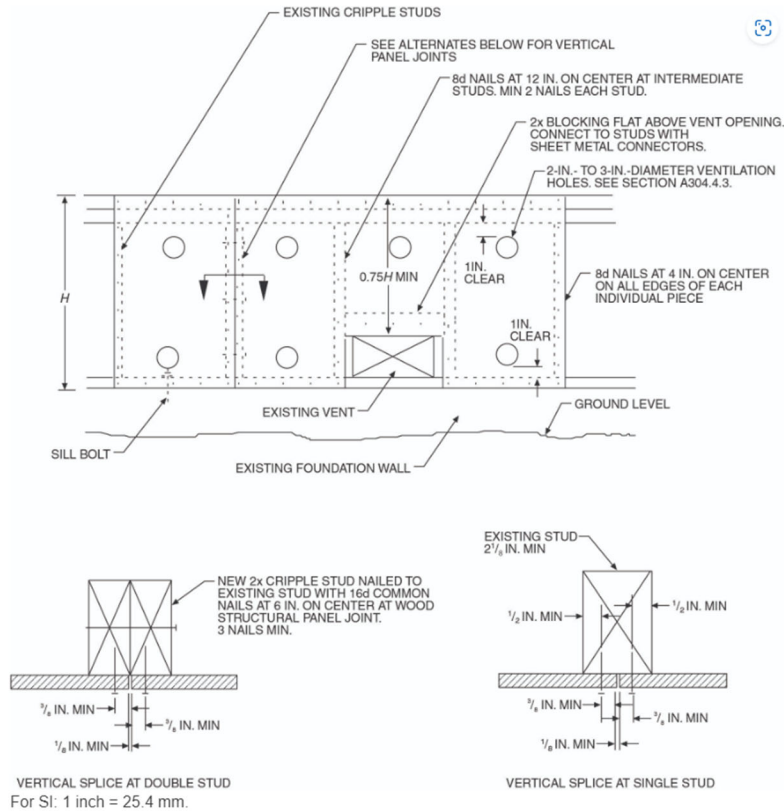

FIGURE A304.4.1(3) [BS] FIGURE A304.4.1(3) PARTIAL CRIPPLE STUD WALL ELEVATION

**Note to RCC**

**Figure A304.4.4(3) is formerly A3-7**

**[BS] A304.4.1.1 Sheathing installation requirements.** Wood structural panel sheathing shall be not less than  $1\frac{5}{32}$ -inch (12 mm) thick and shall be installed in accordance with Figure A3-5 A304.4.1(1) or A3-6 A304.4.1(2). Individual pieces of wood structural panels shall be nailed with 8d common nails spaced 4 inches (102 mm) on center at all edges and 12 inches (305 mm) on center at each intermediate support with not less than two nails for each stud. Nails shall be driven so that their heads are flush with the surface of the sheathing and shall penetrate the supporting member not less than  $1\frac{1}{2}$  inches (38 mm). When a nail fractures the surface, it shall be left in place and not counted as part of the required nailing. A new 8d nail shall be located within 2 inches (51 mm) of the discounted nail and be hand-driven flush with the sheathing surface. Where the installation involves horizontal joints, those joints shall occur over nominal 2-inch by 4-inch (51 mm by 102 mm) blocking installed with the nominal 4-inch (102 mm) dimension against the face of the plywood.

Vertical joints at adjoining pieces of wood structural panels shall be centered on studs such that there is a minimum  $\frac{1}{8}$  inch (3.2 mm) between the panels. Where required edge distances cannot be maintained because of the width of the existing stud, a new stud shall be added adjacent to the existing studs and connected in accordance with Figure A3-7 A304.4.1(3).

**[BS] A304.4.2 Distribution and amount of bracing.** See Table A3-A A304.3.1 and Figure A3-I A304.4.2 for the distribution and amount of bracing required for each wall line. Each braced panel length must be not less than two times the height of the cripple stud. Where the minimum amount of bracing prescribed in Table A3-A A304.3.1 cannot be installed along any walls, the bracing must be designed in accordance with Section A301.3.

**Exception:** Where physical obstructions such as fireplaces, plumbing or heating ducts interfere with the placement of cripple wall bracing, the bracing shall then be placed as close to the obstruction as possible. The total amount of bracing required shall not be reduced because of obstructions.



1. Placement and installation of new adhesive or expansion anchors installed in existing foundations. Special inspection is not required for adhesive anchors installed in existing foundations regulated by the prescriptive provisions of this chapter.
2. Installation and nailing of new cripple wall bracing.
3. Any work shall be subject to special inspection where required by the *code official* in accordance with the building code.

**[BS] A304.5.1 Nails.** All nails specified in this chapter shall be common wire nails of the following diameters and lengths:

1. 8d nails = 0.131 inch (3.3 mm) by 2<sup>1</sup>/<sub>2</sub> inches (64 mm).
2. 10d nails = 0.148 inch (3.8 mm) by 3 inches (76 mm).
3. 12d nails = 0.148 inch (3.8 mm) by 3<sup>1</sup>/<sub>4</sub> inches (83 mm).
4. 16d nails = 0.162 inch (4.1 mm) by 3<sup>1</sup>/<sub>2</sub> inches (89 mm).

Nails used to attach metal framing connectors directly to wood members shall be as specified by the connector manufacturer in an *approved* report.

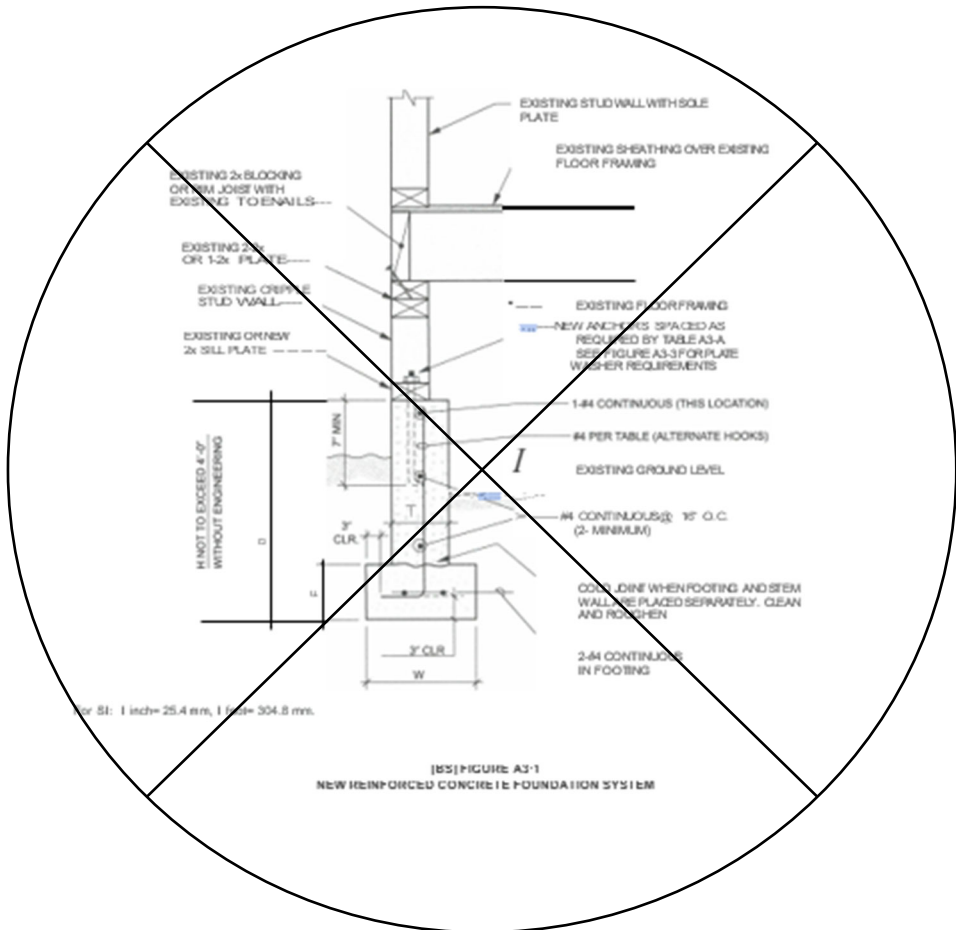

[B5] FIGURE A3-1  
NEW REINFORCED CONCRETE FOUNDATION SYSTEM

| NUMBER OF STORIES | MINIMUM FOUNDATION DIMENSIONS |                      |                       |                       |                         | MINIMUM FOUNDATION REINFORCING       |                                      |
|-------------------|-------------------------------|----------------------|-----------------------|-----------------------|-------------------------|--------------------------------------|--------------------------------------|
|                   | W                             | F                    | I                     | H                     | M                       | VERTICAL REINFORCING                 | HORIZONTAL REINFORCING               |
| 1                 | 12 inches<br>(305 mm)         | 8 inches<br>(203 mm) | 12 inches<br>(305 mm) | 6 inches<br>(152 mm)  | 5:24 inches<br>(610 mm) | #4 @ 24 inches<br>(610 mm) on center | #4 continuous at top of<br>stem wall |
| 2                 | 15 inches<br>(381 mm)         | 7 inches<br>(178 mm) | 15 inches<br>(381 mm) | 8 inches<br>(203 mm)  | 24 inches<br>(610 mm)   | #4 @ 24 inches<br>(610 mm) on center | #4 @ 18 inches<br>(457 mm) on center |
| 3                 | 18 inches<br>(457 mm)         | 8 inches<br>(203 mm) | 24 inches<br>(610 mm) | 10 inches<br>(254 mm) | 36 inches<br>(914 mm)   | #4 @ 24 inches<br>(610 mm) on center | #4 @ 18 inches<br>(457 mm) on center |

- a. Where frost conditions occur, the minimum depth shall extend below the frost line.
- b. The ground surface along the interior side of the foundation may be excavated to the elevation of the top of the footing.
- c. Where the soil is designated as expansive, the foundation depth and reinforcement shall be approved by the code official.

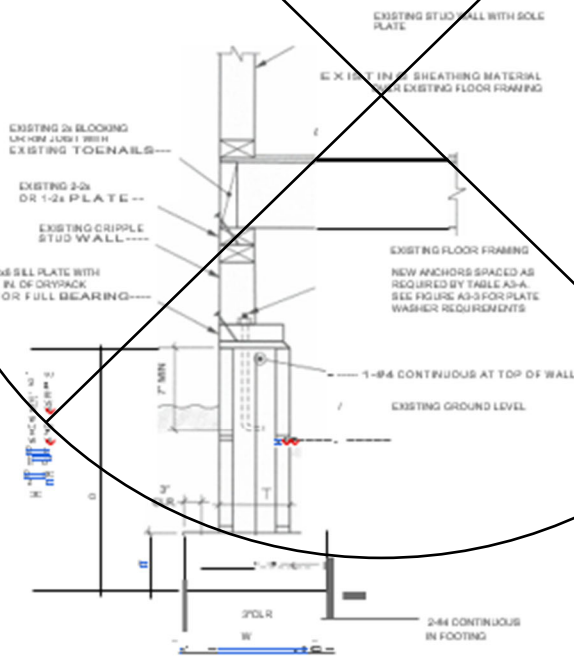

For S1: 1 inch= 25.4 mm, 1 foot= 304.8 mm.

FIGURE A3-2  
NEW MASONRY CONCRETE FOUNDATION



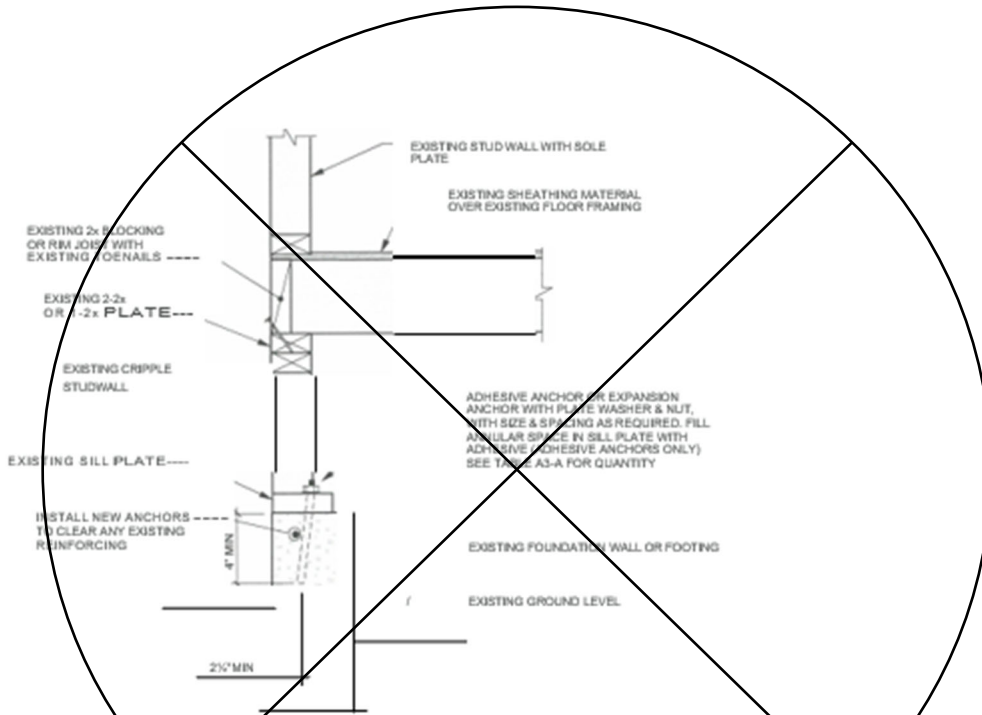

For SI: 1 inch = 25.4 mm.

**NOTES:**

1. Plate washers shall comply with the following:  
 $\frac{1}{4}$ -inch anchor or bolt-3 inches x 3 inches x 0.220 inch minimum.  
 $\frac{3}{8}$ -inch anchor or bolt-3 inches x 3 inches x 0.220 inch minimum.  
 A diagonal slot in the plate washer is permitted in accordance with Table A3-A, Footnote b.
2. See Figure A3-5 or A3-6 for cripple wall bracing.

FIGURE A3-3  
SILL PLATE BOLTING TO EXISTING FOUNDATION

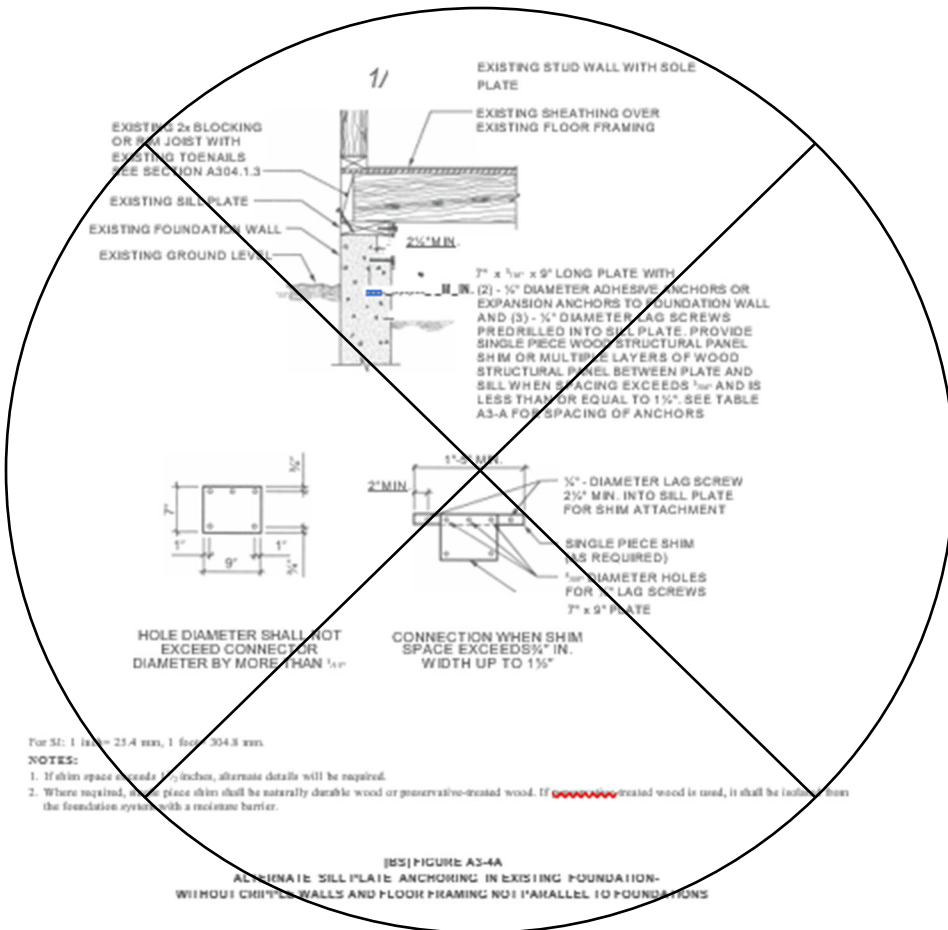

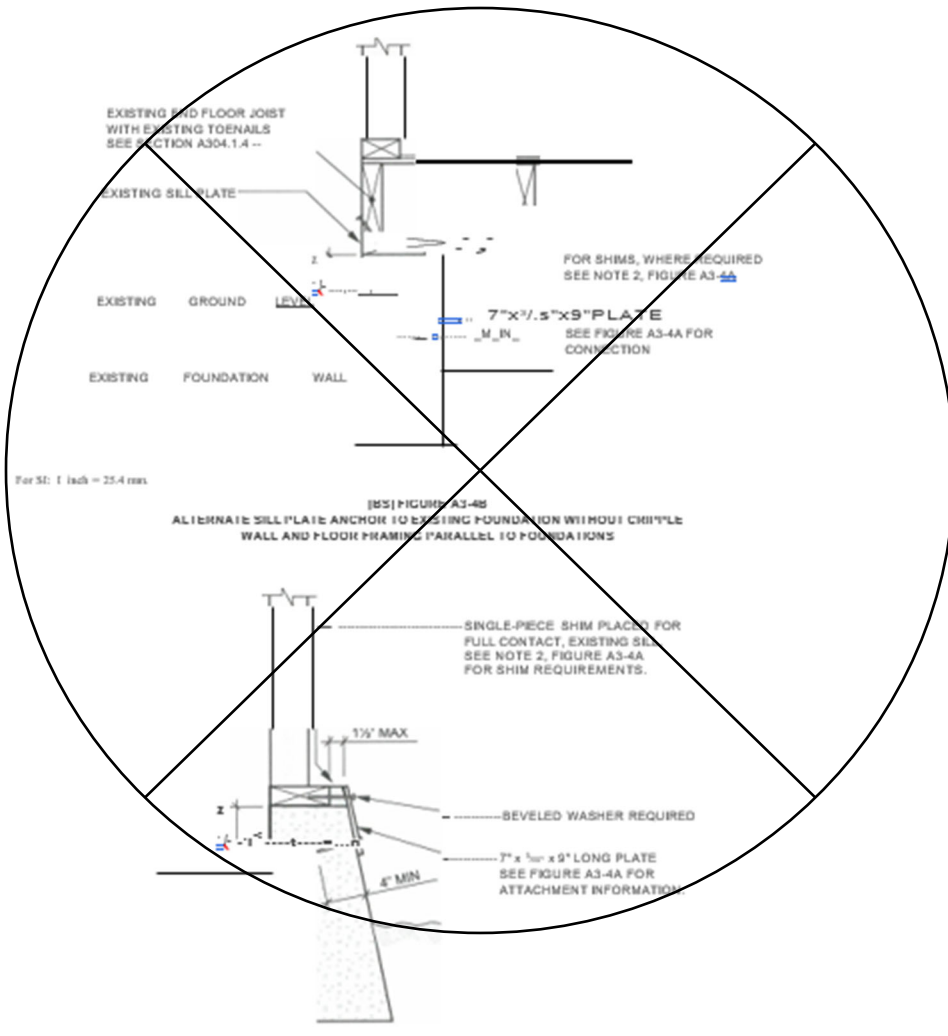

[BS] FIGURE A3-4C  
SILL PLATE ANCHORING TO EXISTING FOUNDATION-ALTERNATE CONNECTION FOR BATTERED FOOTING

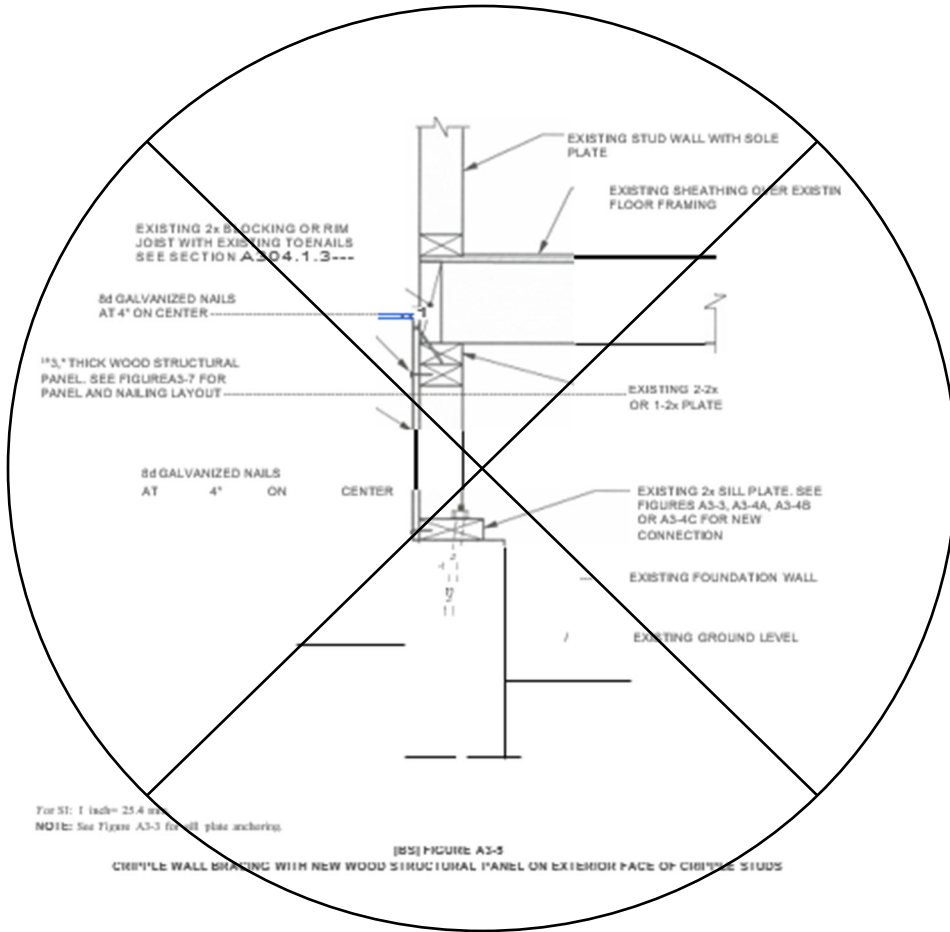

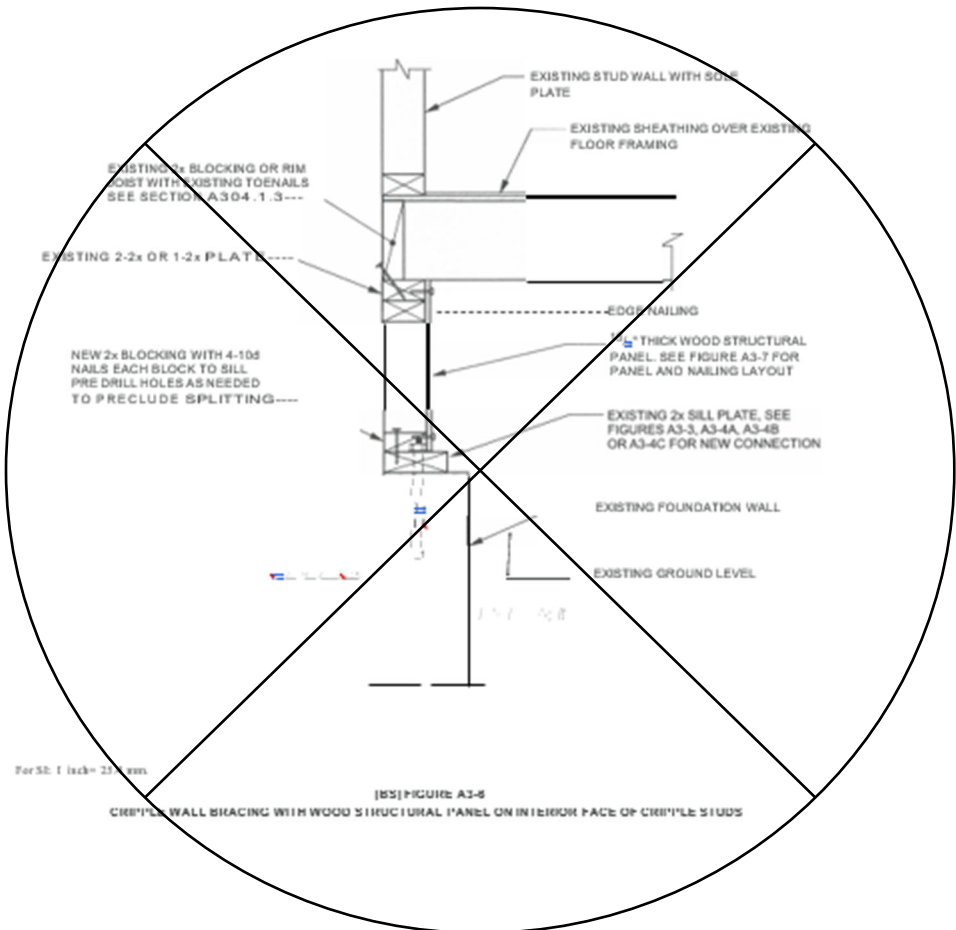

For 50: 1 inch = 25 mm

[BS] FIGURE A3-6  
CRIPPLE WALL BRACING WITH WOOD STRUCTURAL PANEL ON INTERIOR FACE OF CRIPPLE STUDS

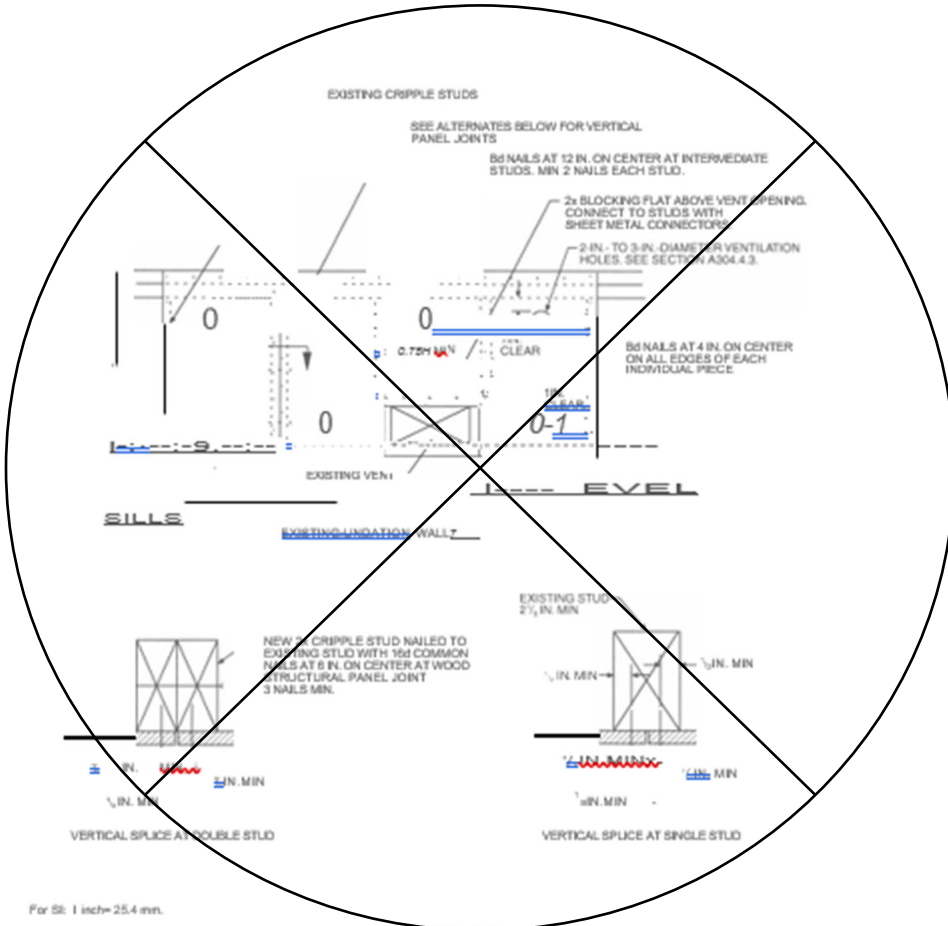

(S6) FIGURE A2-7  
PARTIAL CRIPPLE STUD WALL ELEVATION

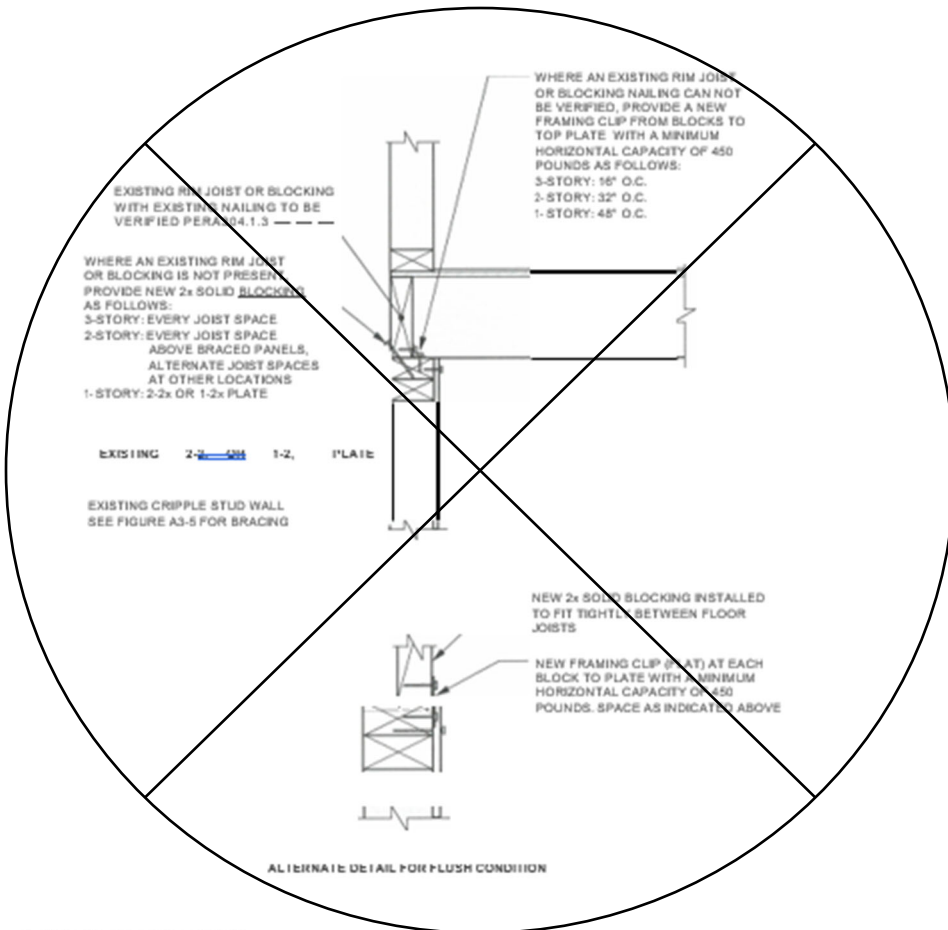

For SF: 1 inch= 25.4 mm, 1 pound= 4.4 N.

NOTE: See manufacturing instructions for nail sizes associated with metal framing clips.

[BS] FIGURE A3-8A  
 TYPICAL FLOOR TO CRIPPLE WALL CONNECTION (FLOOR JOISTS NOT PARALLEL TO FOUNDATIONS)

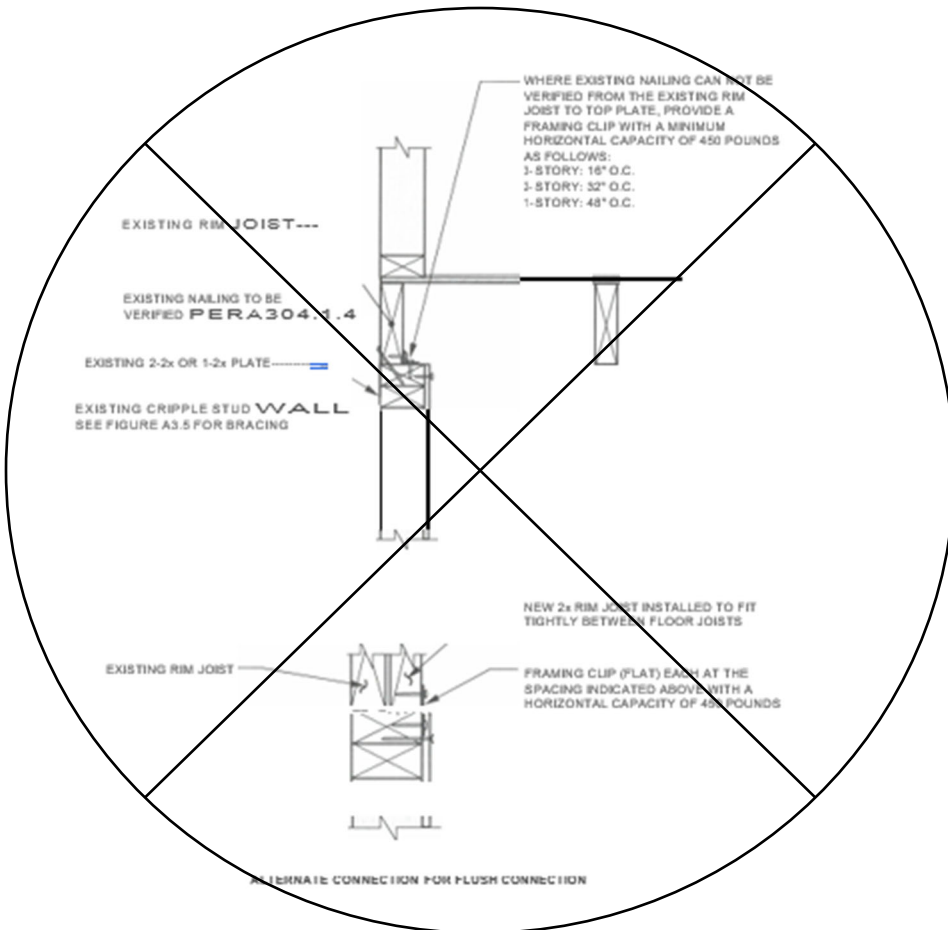

For SI: 1 inch= 25.4 mm, 1 pound= 4.4 N.

NOTE: See manufacturing instructions for nail sizes associated with metal framing clips.

[B5] FIGURE A3-86  
TYPICAL FLOOR TO CRIPPLE WALL CONNECTION (FLOOR JOISTS PARALLEL TO FOUNDATIONS)



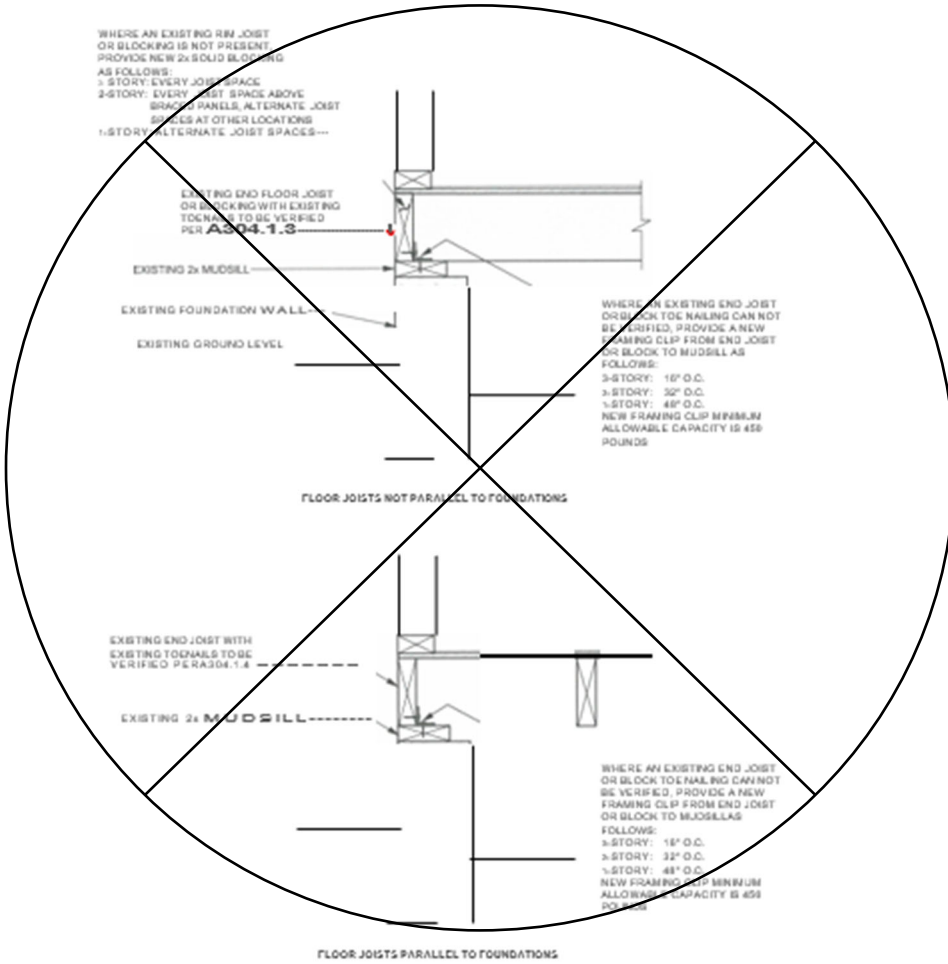

For SI: 1 inch= 25.4 mm

**NOTES:**

1. See Section A304.3 for all plate exchange.
2. See manufacturing instructions for nail sizes associated with metal framing clips.

[SI] PICTURE A3-8C  
 TYPICAL FLOOR TO MUDDSILL CONNECTIONS

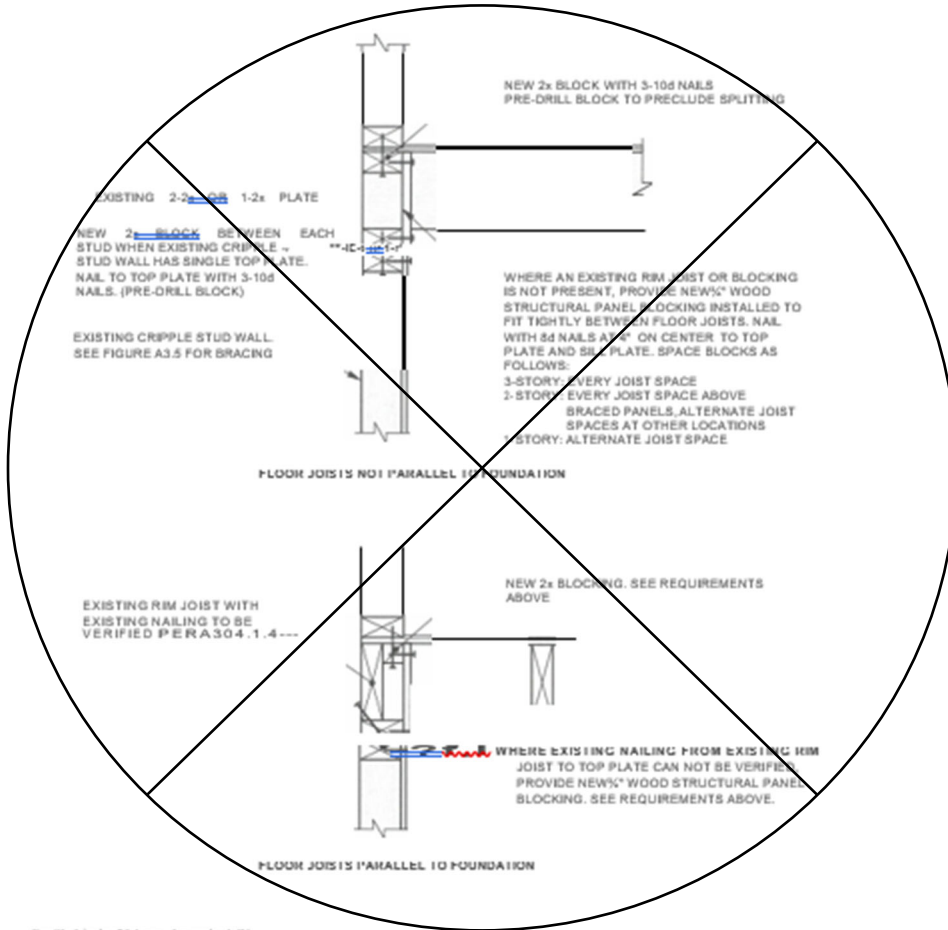

For SI: 1 inch= 25.4 mm, 1 pound= 4.4N.  
**NOTE:** See Section A304.4 for cripple wall bracing.

**FIGURE A3-2**  
 ALTERNATE FLOOR FRAMING TO CRIPPLE WALL CONNECTION

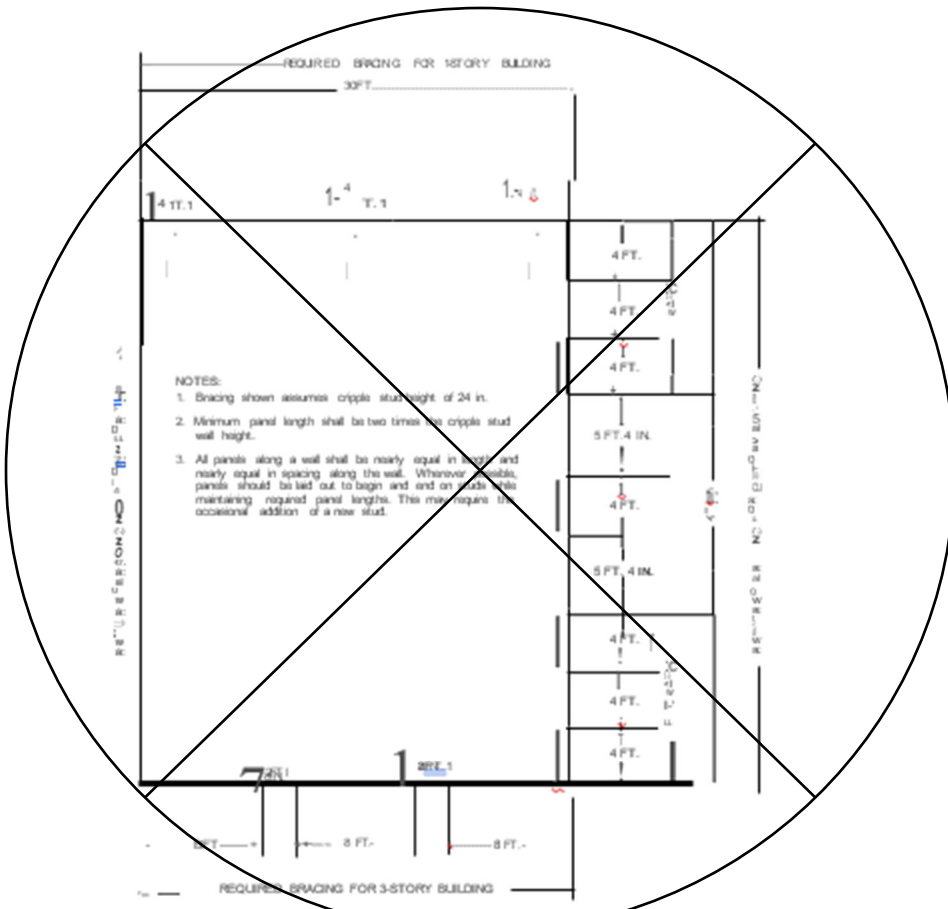

- NOTES:
1. Bracing shown assumes cripple stud height of 24 in.
  2. Minimum panel length shall be two times the cripple stud wall height.
  3. All panels along a wall shall be nearly equal in length and nearly equal in spacing along the wall. Whenever possible, panels should be laid out to begin and end on studs, while maintaining required panel lengths. This may require the occasional addition of a new stud.

Bracing determination:  
 1-story building—each end and not less than 40% of wall length.  
 Transverse wall—30 ft. x 0.40 = 12 ft. minimum panel length = 4 ft. O in.  
 1-story building—each end and not less than 50% of wall length.  
 Longitudinal wall—40 ft. x 0.50 = 20 ft. O in. minimum of bracing.  
 1-story building—each end and not less than 50% of wall length.  
 Transverse wall—30 ft. x 0.50 = 24 ft. O in. minimum of bracing.  
 \*See Table A3-A for buildings with both plaster walls and roofing exceeding 6 psf (287 N/m<sup>2</sup>).

For 5/8 inch = 25.4 mm, 1 foot = 304.8 mm.

[B5] FIGURE A3-10-  
 FLOOR PLAN-CRIPPLE WALL BRACING LAYOUT

## CHAPTER A4

# EARTHQUAKE RISK REDUCTION IN WOOD-FRAME RESIDENTIAL BUILDINGS WITH SOFT, WEAK OR OPEN FRONT WALLS

### SECTION A401 GENERAL

[BS] **A401.1 Purpose.** The purpose of this chapter is to promote public welfare and safety by reducing the risk of death or injury as a result of the effects of earthquakes on existing wood-frame, multiple-unit residential buildings. The ground motions of past earthquakes have caused the loss of human life, personal injury and property damage in these types of buildings. This chapter creates minimum standards to strengthen the more vulnerable portions of these structures. Where fully followed, these minimum standards will improve the performance of these buildings but will not necessarily prevent all earthquake-related damage.

[BS] **A401.2 Scope.** The provisions of this chapter shall apply to ~~all existing Occupancy Group R-1 and R-2~~ buildings of wood construction that contain residential occupancies and are assigned to Risk Category II, and ~~or portions thereof~~ where the structure has a soft, weak, or open-front wall line, and there exists one or more stories above.

### SECTION A402 DEFINITIONS

[BS] **A402.1 Definitions.** Notwithstanding the applicable definitions, symbols and notations in the building code, the following definitions shall apply for the purposes of this chapter:

[BS] **ASPECT RATIO.** The span-width ratio for horizontal diaphragms and the height-length ratio for shear walls.

~~[BS] **GROUND FLOOR.** Any floor whose elevation is immediately accessible from an adjacent grade by vehicles or pedestrians. The ground floor portion of the structure does not include any floor that is completely below adjacent grades.~~

[BS] **NONCONFORMING STRUCTURAL MATERIALS.** Wall bracing materials other than wood structural panels or diagonal sheathing.

[BS] **OPEN-FRONT WALL LINE.** An exterior wall line, without vertical elements of the lateral force-resisting system, that requires tributary seismic forces to be resisted by diaphragm rotation or excessive cantilever beyond parallel lines of shear walls. Diaphragms that cantilever more than 25 percent of the distance between lines of lateral force-resisting elements from which the diaphragm cantilevers shall be considered to be excessive. Exterior exit balconies of 6 feet (1829 mm) or less in width shall not be considered excessive cantilevers.

[BS] **RETROFIT.** An improvement of the lateral force-resisting system by *alteration* of existing structural elements or *addition* of new structural elements.

[BS] **SOFT WALL LINE.** A wall line whose lateral stiffness is less than that required by story drift limitations or deformation compatibility requirements of this chapter. In lieu of analysis, a soft wall line may be defined as a wall line in a story where the story stiffness is less than 70 percent of the story above for the direction under consideration.

[BS] **STORY.** A story as defined by the building code, including any basement or underfloor space of a building with cripple walls exceeding 4 feet (1219 mm) in height.

~~[BS] **STORY STRENGTH.** The total strength of all seismic-resisting elements sharing the same story shear in the direction under consideration.~~

[BS] **WALL LINE.** Any length of wall along a principal axis of the building used to provide resistance to lateral loads. Parallel wall lines separated by less than 4 feet (1219 mm) shall be considered to be one wall line for the distribution of loads.

[BS] **WEAK WALL LINE.** A wall line in a story where the story strength is less than 80 percent of the story above in the direction under consideration.

## SECTION A403 ANALYSIS AND DESIGN

**[BS] A403.1 General.** Modifications required by the provisions in this chapter shall be designed in accordance with the *International Building Code* provisions for new construction, except as modified by this chapter.

**Exception:** Buildings for which the prescriptive measures provided in Section A404 apply and are used.

~~No alteration~~ *Alteration* of the existing lateral force-resisting system or vertical load-carrying system shall not reduce the strength or stiffness of the existing structure, unless the altered structure would remain in conformance to the building code and this chapter.

**[BS] A403.2 Scope of analysis.** This chapter requires the *alteration, repair*, replacement or addition of structural elements and their connections to meet the strength and stiffness requirements herein. The lateral load-path analysis shall include the resisting elements and connections from the wood diaphragm immediately above any soft, weak or open-front wall lines to the foundation soil interface or to the uppermost story of a podium structure comprised of steel, masonry, or concrete structural systems that supports the upper wood-framed structure. Stories above the uppermost story with a soft, weak or open-front wall line shall be considered in the analysis but need not be modified. The lateral load-path analysis for added structural elements shall include evaluation of the allowable soil-bearing and lateral pressures in accordance with the building code. Where any portion of a building within the scope of this chapter is constructed on or into a slope steeper than one unit vertical in three units horizontal (33-percent slope), the lateral force-resisting system at and below the base level diaphragm shall be analyzed for the effects of concentrated lateral forces at the base caused by this hillside condition.

~~**Exception:** When an open front, weak or soft wall line exists because of parking at the ground floor of a two-story building and the parking area is less than 20 percent of the ground floor area, then only the wall lines in the open, weak or soft directions of the enclosed parking area need comply with the provisions of this chapter.~~

**[BS] A403.3 Design base shear and design parameters.** The design base shear in a given direction shall be permitted to be 75 percent of the value required for similar new construction in accordance with the building code. The value of  $R$  used in the design of the strengthening of any story shall not exceed the lowest value of  $R$  used in the same direction at any story above. The system overstrength factor,  $\Omega_0$ , and the deflection amplification factor,  $C_d$ , shall be not less than the largest respective value corresponding to the  $R$  factor being used in the direction under consideration.

### **Exceptions:**

1. For structures assigned to Seismic Design Category B, values of  $R$ ,  $\Omega_0$  and  $C_d$  shall be permitted to be based on the seismic force-resisting system being used to achieve the required strengthening.
2. For structures assigned to Seismic Design Category C or D, values of  $R$ ,  $\Omega_0$  and  $C_d$  shall be permitted to be based on the seismic force-resisting system being used to achieve the required strengthening, provided that when the strengthening is complete, the strengthened structure will not have an extreme weak story irregularity defined as Type 5b in ASCE 7 Table 12.3-2.
3. For structures assigned to Seismic Design Category E, values of  $R$ ,  $\Omega_0$  and  $C_d$  shall be permitted to be based on the seismic force-resisting system being used to achieve the required strengthening, provided that when the strengthening is complete, the strengthened structure will not have an extreme soft story, a weak story, or an extreme weak story irregularity defined, respectively, as Types 1b, 5a and 5b in ASCE 7 Table 12.3-2.
4. For retrofit systems involving different seismic force-resisting systems in the same direction within the same story, resisting elements are permitted to be designed using the least value of  $R$  for the different structural systems found in each independent line of resistance if all of the following conditions are met:
  - 4.1. The building is assigned to *Risk Category* I or II.
  - 4.2. The building height is no more than four stories above grade plane.
  - 4.3. The seismic force-resisting systems of the retrofitted building comprise only wood structural panel shear walls, steel moment-resisting frames, steel cantilever columns and steel-braced frames. Values for  $C$  and  $\Omega_0$  shall be consistent with the  $R$  value used.
5. With reference to ASCE 7 Table 12.2-1, ordinary, intermediate and special steel systems, and all light-frame systems shall be permitted without limitation where those systems are used only for retrofit to comply with the requirements of this chapter.

**[BS] A403.3.1 Expected story strength.** Despite any other requirement of Section A403.3 or A403.4, the total expected strength of retrofit elements added to any story need not exceed 1.7 times the expected strength of the story immediately above in a two-story building, or 1.3 times the expected strength of the story immediately above in a three-story or taller building, as long as the retrofit elements are located symmetrically about the center of mass of the story above, or so as to minimize torsion in the retrofitted story. Calculation of expected story strength and identification of irregularities in Section A403.3 shall be based on the expected strength of all wall lines, even if sheathed with nonconforming materials. The strength of a wall line above the retrofitted story shall be permitted to be reduced to account for inadequate load path or overturning resistance.

**[BS] A403.3.2 Seismicity parameters, site class and geologic hazards.** For any site designated as Site Class E, the value of F shall be taken as 1.2. Site-specific procedures are not required for compliance with this chapter. Mitigation of existing geologic site hazards such as liquefiable soil, fault rupture or landslide is not required for compliance with this chapter.

**[BS] A403.4 Story drift limitations.** The calculated story drift for each retrofitted story shall not exceed the allowable deformation compatible with all vertical load-resisting elements and 0.025 times the story height. The calculated story drift shall not be reduced by the effects of horizontal diaphragm stiffness but shall be increased where these effects produce rotation. Drift calculations shall be in accordance with the building code.

**[BS] A403.4.1 Pole structures.** The effects of rotation and soil stiffness shall be included in the calculated story drift where lateral loads are resisted by vertical elements whose required depth of embedment is determined by pole formulas. The coefficient of subgrade reaction used in deflection calculations shall be based on a geotechnical investigation conducted in accordance with the building code.

**[BS] A403.5 Deformation compatibility and P  $\Delta$  effects.** The requirements of the building code shall apply, except as modified herein. Structural framing elements and their connections not required by design to be part of the lateral force-resisting system shall be designed and detailed to be adequate to maintain support of expected gravity loads when subjected to the expected deformations caused by seismic forces. Increased demand caused by P  $\Delta$  effects and story sidesway stability shall be considered in retrofit stories that rely on the strength and stiffness of cantilever columns for lateral resistance.

**[BS] A403.6 Ties and continuity.** All parts of the structure included in the scope of Section A403.2 shall be interconnected as required by the building code.

**[BS] A403.7 Collector elements.** Collector elements shall be provided to transfer the seismic forces between the elements within the scope of Section A403.2.

#### **[BS] A403.8 ~~Horizontal Floor~~ diaphragms.**

~~The strength of an existing horizontal diaphragm sheathed with wood structural panels or diagonal sheathing need not be investigated unless the diaphragm is required to transfer lateral forces from vertical elements of the seismic force-resisting system above the diaphragm to elements below the diaphragm because of an offset in placement of the elements.~~

~~Rotational effects shall be accounted for when asymmetric wall stiffness increases shear demands.~~

Floor diaphragms within the scope of Section A403.2 shall be shown to have adequate strength at the following locations:

1. For straight lumber sheathed diaphragms without integral hardwood flooring throughout the diaphragm: The code official is authorized to waive the requirement where it is shown that the condition occurs in areas small enough not to affect overall building performance.
2. For all other diaphragms adequate strength shall be shown to be provided at locations where forces are transferred between the diaphragm and each new or strengthened vertical element of the seismic force-resisting system. Collector elements shall be provided where needed to distribute the transferred force over a greater length of diaphragm.

**Exception:** Where the existing vertical elements of the seismic force-resisting system are shown to comply with this chapter, diaphragms need not be evaluated.

#### **[BS] A403.9 Wood-framed shear walls.**

Wood-framed shear walls shall have strength and stiffness sufficient to resist the seismic loads and shall conform to the requirements of this section. Where new sheathing is applied to existing studs to create new wood-framed shear walls, the new wall elements shall be considered bearing wall systems for purposes of determining seismic design parameters.

##### **[BS] A403.9.1 Gypsum or cement plaster products.**

Gypsum or cement plaster products shall not be used to provide ~~lateral resistance in a soft or weak story or in a~~

~~story with an open front wall line, whether or not new elements are added to mitigate the soft, weak or open-front condition; the strength required by Section A403.3 or the stiffness required by Section A403.4.~~

**[BS] A403.9.2 Wood structural panels.**

**[BS] A403.9.2.1 Drift limit.** Wood structural panel shear walls shall meet the story drift limitation of Section A403.4. Conformance to the story drift limitation shall be determined by *approved* testing or calculation. Individual shear panels shall be permitted to exceed the maximum aspect ratio, provided that the allowable story drift and allowable shear capacities are not exceeded.

**[BS] A403.9.2.2 Openings.** Shear walls are permitted to be designed for continuity around openings in accordance with the building code. Blocking and steel strapping shall be provided at corners of the openings to transfer forces from discontinuous boundary elements into adjoining panel elements. Alternatively, perforated shear wall provisions of the building code are permitted to be used.

**[BS] A403.9.3 Hold-down connectors.**

**[BS] A403.9.3.1 Expansion anchors in tension.** Expansion anchors that provide tension strength by friction resistance shall not be used to connect hold-down devices to existing concrete or masonry elements.

**[BS] A403.9.3.2 Required depth of embedment.** The required depth of embedment or edge distance for the anchor used in the hold-down connector shall be provided in the concrete or masonry below any plain concrete slab unless satisfactory evidence is submitted to the *code official* that shows that the concrete slab and footings are of monolithic construction.

**A403.10 Steel retrofit systems.** Steel retrofit systems shall have strength and stiffness sufficient to resist the seismic loads and shall conform to the requirements of this section.

**A403.10.1 Special moment frames.** Steel special moment frames shall comply with all applicable provisions of AISC 341, except that Section E3.4a addressing strong-column/weak-beams of AISC 341, is not required for columns that carry no gravity load.

**A403.10.2 Inverted moment frame systems.** Cantilevered column systems shall be permitted to be designed as inverted special, intermediate or ordinary moment frames, with corresponding moment frame seismic design coefficients, where the system satisfies the following conditions:

1. The columns carry no gravity load.
2. The columns are configured in pairs or larger groups connected by a continuous reinforced concrete foundation or grade beam.
3. The foundation or grade beam shall be designed to resist the expected plastic moment at the base of each column, computed as  $R_p F_p Z$  in accordance with AISC 341.
4. The flexibility of the foundation or grade beam, considering cracked section properties of the reinforced concrete, shall be included in computing the deformation of the steel frame system.
5. The column height shall be taken as twice the actual height when checking lateral torsional buckling.

## **SECTION A404 PRESCRIPTIVE MEASURES FOR WEAK STORY**

**[BS] A404.1 Limitation.** These prescriptive measures shall apply only to two-story buildings and only where deemed appropriate by the *code official*. These prescriptive measures rely on rotation of the second floor diaphragm to distribute the seismic load between the side and rear walls around a ground floor open area. In the absence of an existing floor diaphragm of wood structural panel or diagonal sheathing at the top of the first story, a new wood structural panel diaphragm of minimum thickness of  $3/4$  inch (19.1 mm) and with 10d common nails at 6 inches (152 mm) on center shall be applied.

**[BS] A404.1.1 Additional conditions.** To qualify for these prescriptive measures, the following additional conditions need to be satisfied by the retrofitted structure:

- Diaphragm aspect ratio  $L/W$  is less than 0.67, where  $W$  is the diaphragm dimension parallel to the soft, weak or open-front wall line and  $L$  is the distance in the orthogonal direction between that wall line and the rear wall of the ground floor open area.
- Minimum length of side shear walls = 20 feet (6096 mm).
- Minimum length of rear shear wall = three-fourths of the total rear wall length.
- Plan or vertical irregularities shall not be other than a soft, weak or open-front wall line.

5. Roofing weight less than or equal to 5 pounds per square foot (240 N/m<sup>2</sup>).
6. Aspect ratio of the full second floor diaphragm meets the requirements of the building code for new construction.

**[BS] A404.2 Minimum required retrofit.**

**[BS] A404.2.1 Anchor size and spacing.** The anchor size and spacing shall be not less than  $\frac{3}{4}$  inch (19.1 mm) in diameter at 32 inches (813 mm) on center. Where existing anchors are inadequate, supplemental or alternative *approved* connectors (such as new steel plates bolted to the side of the foundation and nailed to the sill) shall be used.

**[BS] A404.2.2 Connection to floor above.** Shear wall top plates shall be connected to blocking or rim joist at upper floor with not less than 18-gage galvanized steel angle clips  $4\frac{1}{2}$  inches (114 mm) long with 12-8d nails spaced not farther than 16 inches (406 mm) on center, or by equivalent shear transfer methods.

**[BS] A404.2.3 Shear wall sheathing.** The shear wall sheathing shall be not less than  $\frac{15}{32}$ -inch (11.9 mm), 5-ply Structural I with 10d nails at 4 inches (102 mm) on center at edges and 12 inches (305 mm) on center at field; blocked all edges with 3 by 4 board or larger. Where existing sill plates are less than 3-by thick, place flat 2-by on top of sill between studs, with flat 18-gage galvanized steel clips  $4\frac{1}{2}$  inches (114 mm) long with 12-8d nails or  $\frac{3}{8}$ -inch-diameter (9.5 mm) lags through blocking for shear transfer to sill plate. Stagger nailing from wall sheathing between existing sill and new blocking. Anchor new blocking to foundation as specified in this section.

**[BS] A404.2.4 Shear wall hold-downs.** Shear walls shall be provided with hold-down anchors at each end. Two hold-down anchors are required at intersecting corners. Hold-downs shall be *approved* connectors with a minimum  $\frac{5}{8}$ -inch-diameter (15.9 mm) threaded rod or other *approved* anchor with a minimum allowable load of 4,000 pounds (17.8 kN). Anchor embedment in concrete shall be not less than 5 inches (127 mm). Tie-rod systems shall be not less than  $\frac{5}{8}$  inch (15.9 mm) in diameter unless using high-strength cable. High-strength cable elongation shall not exceed  $\frac{5}{8}$  inch (15.9 mm) under a 4,000 pound (17.8 kN) axial load.

## **SECTION A405 MATERIALS OF CONSTRUCTION**

**[BS] A405.1 New materials.** New materials shall meet the requirements of the *International Building Code*, except where allowed by this chapter.

**[BS] A405.2 Allowable foundation and lateral pressures.** The use of default values from the building code for continuous and isolated concrete spread footings shall be permitted. For soil that supports embedded vertical elements, Section A403.4.1 shall apply.

**[BS] A405.3 Existing materials.** The physical condition, strengths and stiffnesses of existing building materials shall be taken into account in any analysis required by this chapter. The verification of existing materials conditions and their conformance to these requirements shall be made by physical observation, material testing or record drawings as determined by the registered design professional subject to the approval of the *code official*.

**[BS] A405.3.1 Wood-structural-panel shear walls.**

**[BS] A405.3.1.1 Existing nails.** Where the required calculations rely on design values for common nails or surfaced dry lumber, their use in construction shall be verified by exposure.

**[BS] A405.3.1.2 Existing plywood.** Where verification of the existing plywood is by use of record drawings alone, plywood shall be assumed to be of three plies.

**[BS] A405.3.2 Existing wood framing.** Wood framing is permitted to use the design stresses specified in the building code under which the building was constructed or other stress criteria *approved* by the *code official*.

**[BS] A405.3.3 Existing structural steel.** All existing structural steel shall be permitted to be assumed to comply with ASTM A36. Existing pipe or tube columns shall be assumed to be of minimum wall thickness unless verified by testing or exposure.

**[BS] A405.3.4 Existing concrete.** All existing concrete footings shall be permitted to be assumed to be plain concrete with a compressive strength of 2,000 pounds per square inch (13.8 MPa). Existing concrete compressive strength taken greater than 2,000 pounds per square inch (13.8 MPa) shall be verified by testing, record drawings or department records.

**[BS] A405.3.5 Existing sill plate anchorage.** The analysis of existing cast-in-place anchors shall be permitted to assume proper anchor embedment for purposes of evaluating shear resistance to lateral loads.



## **SECTION A406 CONSTRUCTION DOCUMENTS**

**[BS] A406.1 General.** The plans shall show all information necessary for plan review and for construction and shall accurately reflect the design. The plans shall contain a note that states that this retrofit was designed in compliance with the criteria of this chapter.

**[BS] A406.2 Existing construction.** The plans shall show existing diaphragm and shear wall sheathing and framing materials; fastener type and spacing; diaphragm and shear wall connections; continuity ties; collector elements; and the portion of the existing materials that needs verification during construction. If the cap allowed by Section A403.3.1 is used to limit the scope of retrofit, the foregoing information shall be shown for each retrofitted story and at least one story above the uppermost retrofitted story. If the cap allowed by Section A403.3.1 is not used, the foregoing information need only be shown for each retrofitted story and for the floor at the top of that story.

### **[BS] A406.3 New construction.**

**[BS] A406.3.1 Foundation plan elements.** The foundation plan shall include the size, type, location and spacing of all anchor bolts with the required depth of embedment, edge and end distance; the location and size of all shear walls and all columns for braced frames or moment frames; referenced details for the connection of shear walls, braced frames or moment-resisting frames to their footing; and referenced sections for any grade beams and footings.

**[BS] A406.3.2 Framing plan elements.** The framing plan shall include the length, location and material of shear walls; the location and material of frames; references or details for the column-to-beam connectors, beam-to-wall connections and shear transfers at floor and roof diaphragms; and the required nailing and length for wall top plate splices.

**[BS] A406.3.3 Shear wall schedule, notes and details.** Shear walls shall have a referenced schedule on the plans that includes the correct shear wall capacity in pounds per foot (N/m); the required fastener type, length, gage and head size; and a complete specification for the sheathing material and its thickness. The schedule shall also show the required location of 3-inch (76 mm) nominal or two 2-inch (51 mm) nominal edge members; the spacing of shear transfer elements such as framing anchors or added sill plate nails; the required hold-down with its bolt, screw or nail sizes; and the dimensions, lumber grade and species of the attached framing member.

Notes shall show required edge distance for fasteners of structural wood panels and framing members; required flush nailing at the plywood surface; limits of mechanical penetrations; and the sill plate material assumed in the design. The limits of mechanical penetrations shall be detailed showing the maximum notching and drilled hole sizes.

**[BS] A406.3.4 General notes.** General notes shall show the requirements for material testing, special inspection and structural observation.

## **SECTION A407 QUALITY CONTROL**

**[BS] A407.1 Structural observation.** Structural observation, in accordance with Section 1704.6 of the *International Building Code* is required, regardless of seismic design category, height or other conditions. Structural observation shall include visual observation of work for conformance to the *approved* construction documents and confirmation of existing conditions assumed during design.

**A407.2 Contractor responsibility.** Contractor responsibility shall be in accordance with Section 1704.4 of the *International Building Code*.

**A407.3 Testing and inspection.** Structural testing and inspection for new construction materials, submittals, reports and certificates of compliance shall be in accordance with Sections 1704 and 1705 of the *International Building Code*. Work done to comply with this chapter shall not be eligible for Exceptions 1, 2, or 3 of Section 1704.2 of the *International Building Code* or for the exception to Section 1705.13.2 of the *International Building Code*.

## CHAPTER A5

# REFERENCED STANDARDS

### SECTION A501

### REFERENCED STANDARDS

**A501.1 General.** See Table A501.1 for standards that are referenced in various sections of this appendix. Standards are listed by the standard identification with the effective date, standard title, and the section or sections of this appendix that references the standard.

**TABLE A501.1**  
**REFERENCED STANDARDS**

| STANDARD ACRONYM                                       | STANDARD NAME   | SECTIONS HEREIN REFERENCED                                     |
|--|---|--|
| <u>AISC 341-16</u><br><u>AISC 341-22</u>               | <i>Seismic Provisions for Structural Steel Buildings</i>  | A403.10.1, A403.10.2   |
| <u>ASCE/SEI 7—16</u><br><u>ASCE/SEI 7—22</u>           | <i>Minimum Design Loads for Buildings and Other Structures with Supplement No. 1</i>  | A104.1, A205.1, A206.1, A206.2, A206.3, A206.4, A206.7, A403.3 |
| <u>ASTM A36/A36M—14</u><br><u>ASTM A36/A36M—19</u>     | <i>Specification for Carbon Structural Steel</i>  | A405.3.3   |
| <u>ASTM A653/A653M—15</u><br><u>ASTM A653/A653M—20</u> | <i>Standard Specification for Steel Sheet, Zinc Coated (Galvanized) or Zinc-Iron Alloy-Coated (Galvannealed) by Hot-Dip Process</i> | A304.2.6   |
| <u>ASTM B695—04(2009)</u>                              | <i>Standard Specification for Coating of Zinc Mechanically Deposited on Iron and Steel</i>  | A304.2.6   |
| <u>ASTM C67—14</u><br><u>ASTM C67/C67M- 21</u>         | <i>Test Methods of Sampling and Testing Brick and Structural Clay Tile</i>  | A106.2.3.1   |
| <u>ASTM C140/C140M—15</u><br><u>ASTM C140/C140M—21</u> | <i>Standard Test Methods for Sampling and Testing Concrete Masonry Units and Related Units</i>                                      | A106.2.3.1   |
| <u>ASTM C496—96/C496M—11</u>                           | <i>Standard Test Method for Splitting Tensile Strength of Cylindrical Concrete Specimens</i>  | A104.1, A106.2.3.3   |
| <u>ASTM C1531—15</u>                                   | <i>Standard Test Methods for In Situ Measurement of Masonry Mortar Joint Shear Strength Index</i>                                   | A106.2.3.2   |

|                       |   |                    |
|-----------------------|---|--------------------|
| ASTM E488/E488M —15   | <i>Standard Test Methods for Strength of Anchors in Concrete and Masonry Elements</i> | A107.5.1, A107.5.3 |
| ASTM E519/E519M —2010 | <i>Standard Test Method for Diagonal Tension (Shear) in Masonry Assemblages</i>       | A104.1             |

**TABLE A501.1—continued  
REFERENCED STANDARDS**

| <b>STANDARD ACRONYM</b>            | <b>STANDARD NAME</b>   | <b>SECTIONS HEREIN REFERENCED</b>  |
|------------------------------------|--|--|
| IBC—00                             | <i>International Building Code</i>   | A202.1   |
| IBC—03                             | <i>International Building Code</i>   | A202.1   |
| IBC—06                             | <i>International Building Code</i>   | A202.1   |
| IBC—09                             | <i>International Building Code</i>   | A202.1   |
| IBC—12                             | <i>International Building Code</i>   | A202.1   |
| IBC—15                             | <i>International Building Code</i>   | A202.1   |
| IBC—18                             | <i>International Building Code</i>   | A202.1   |
| <u>IBC—21</u>                      | <i>International Building Code</i>   | <u>A202.1</u>  |
| <del>IBC—21</del><br><u>IBC-24</u> | <i>International Building Code</i>   | A102.2, A105.1, A105.4, A202.1, A203.1, A204.1, A205.1, A205.3, A205.3.1, A205.4, A301.3, A304.1.1, A403.1, A405.1, A407.1, A407.2, A407.3 |
| <u>TMS 402-22</u>                  | <i><u>Building Code Requirements and Specifications for Masonry Structures</u></i> | <u>A105.4, Table A1-8.1 (2)</u>  |
| UBC—97                             | <i>Uniform Building Code</i>   | A202.1   |



## APPENDIX B

# SUPPLEMENTARY ACCESSIBILITY REQUIREMENTS FOR EXISTING BUILDINGS AND FACILITIES

*The provisions contained in this appendix are adopted as part of this code.*

### SECTION B101 QUALIFIED HISTORIC BUILDINGS AND FACILITIES

[BE] **B101.1 General.** Qualified *historic buildings* and *facilities* shall comply with Sections B101.2 through B101.5.

[BE] **B101.2 Qualified historic buildings and facilities.** These procedures shall apply to buildings and *facilities* designated as historic structures that undergo *alterations* or a *change of occupancy*.

[BE] **B101.3 Qualified historic buildings and facilities subject to Section 106 of the National Historic Preservation Act.** Where an *alteration* or *change of occupancy* is undertaken to a qualified *historic building* or *facility* that is subject to Section 106 of the National Historic Preservation Act, the federal agency with jurisdiction over the undertaking shall follow the Section 106 process. Where the state historic preservation officer or Advisory Council on Historic Preservation determines that compliance with the requirements for accessible routes, ramps, entrances, or toilet *facilities* would threaten or destroy the historic significance of the building or *facility*, the alternative requirements of Section ~~410.9~~ 306.7.16 for that element are permitted.

[BE] **B101.4 Qualified historic buildings and facilities not subject to Section 106 of the National Historic Preservation Act.** Where an *alteration* or *change of occupancy* is undertaken to a qualified *historic building* or *facility* that is not subject to Section 106 of the National Historic Preservation Act, and the entity undertaking the *alterations* believes that compliance with the requirements for accessible routes, ramps, entrances or toilet *facilities* would threaten or destroy the historic significance of the building or *facility*, the entity shall consult with the state historic preservation officer. Where the state historic preservation officer determines that compliance with the accessibility requirements for accessible routes, ramps, entrances or toilet *facilities* would threaten or destroy the historical significance of the building or *facility*, the alternative requirements of Section ~~410.9~~ 306.7.16 for that element are permitted.

[BE] **B101.4.1 Consultation with interested persons.** Interested persons shall be invited to participate in the consultation process, including state or local accessibility officials, individuals with disabilities, and organizations representing individuals with disabilities.

[BE] **B101.4.2 Certified local government historic preservation programs.** Where the state historic preservation officer has delegated the consultation responsibility for purposes of this section to a local government historic preservation program that has been certified in accordance with Section 101 of the National Historic Preservation Act of 1966 [(16 U.S.C. 470a(c)) and implementing regulations (36 CFR 61.5), the responsibility shall be permitted to be carried out by the appropriate local government body or official.

[BE] **B101.5 Displays.** In qualified *historic buildings* and *facilities* where alternative requirements of Section 306.7.16 are permitted, displays and written information shall be located where they can be seen by a seated person. Exhibits and signs displayed horizontally shall be 44 inches (1120 mm) maximum above the floor.

### SECTION B102 FIXED TRANSPORTATION FACILITIES AND STATIONS

[BE] **B102.1 General.** Existing fixed transportation *facilities* and stations shall comply with Section B102.2.

[BE] **B102.2 Existing facilities—key stations.** Rapid rail, light rail, commuter rail, intercity rail, high-speed rail and other fixed guideway systems, altered stations, and intercity rail and key stations, as defined under criteria established by the Department of Transportation in Subpart C of 49 CFR Part 37, shall comply with Sections B102.2.1 through B102.2.3.

[BE] **B102.2.1 Accessible route.** ~~At least one~~ One accessible route, or more, from an accessible entrance to those areas necessary for use of the transportation system shall be provided. The accessible route shall include the features specified in Appendix E109.2 of the *International Building Code*, except that escalators shall comply with *International Building Code* Section 3004.2.2 of the *International Building Code*. Where technical unfeasibility in existing stations requires the accessible route to lead from the public way to a paid area of the transit system, an accessible fare collection machine complying with ~~*International Building Code* Appendix E109.2.3~~ Section

E109.2.3 of the *International Building Code* shall be provided along such accessible route.

**[BE] B102.2.2 Platform and vehicle floor coordination.** Station platforms shall be positioned to coordinate with vehicles in accordance with applicable provisions of 36 CFR Part 1192. Low-level platforms shall be 8 inches (250 mm) minimum above top of rail.

**Exception:** Where vehicles are boarded from sidewalks or street-level, low-level platforms shall be permitted to be less than 8 inches (250 mm).

**[BE] B102.2.3 Direct connections.** New direct connections to commercial, retail or residential *facilities* shall, to the maximum extent feasible, have an accessible route complying with Section 705.2 306.7.1 from the point of connection to boarding platforms and transportation system elements used by the public. Any elements provided to facilitate future direct connections shall be on an accessible route connecting boarding platforms and transportation system elements used by the public.

## SECTION B103 DWELLING UNITS AND SLEEPING UNITS

**[BE] B103.1 Communication features.** Where dwelling units and sleeping units are altered or added, the requirements of Section E104.2 of the *International Building Code* shall apply only to the units being altered or added until the number of units with accessible communication features complies with the minimum number required for new construction.

## SECTION B104 REFERENCED STANDARDS

~~Y3.H626 2P National Historic Preservation J101.2, 43/933 Act of 1966, as amended 1101.3, 3rd Edition, Washington, DC: 1101.3.2 US Government Printing Office, 1993.~~

~~2012 International Building Code. Washington, DC: International Code Council, 2011.~~

~~49 CFR Part 37.43 (e), Alteration of Transportation Facilities by Public Entities, Department of Transportation, 400 7th Street SW, Room 8102, Washington, DC 20590-0001.~~

**[BE] B104.1 General.** See Table B104.1 for standards that are referenced in various sections of this appendix. Standards are listed by the standard identification with the effective date, standard title, and the section or sections of this appendix that reference the standard.

**[BE] TABLE B104.1  
REFERENCED STANDARDS**

| <u>STANDARD ACRONYM</u> | <u>STANDARD NAME</u>  | <u>SECTIONS HEREIN REFERENCED</u> |
|-------------------------|---|-----------------------------------|
| <u>Y3.H626 2P</u>       | <u>National Historic Preservation J101.2, 43/933 Act of 1966 as amended J101.3, 3rd Edition</u>               | <u>B101.3, B101.4, B101.4.2</u>   |
| <u>IBC—21</u>           | <u>International Building Code®</u>   | <u>B102.2.1, B103.1</u>           |
| <u>36 CFR Part 1192</u> | <u>Americans with Disabilities Act Guidelines for Transportation Vehicles—Rapid Rail Vehicles and Systems</u> | <u>B102.2.2</u>                   |

49 CFR Part  
37 Subpart C

*Alteration of Transportation  
Facilities by Public Entities  
Department of Transportation*

B102.2

## APPENDIX C: GUIDELINES FOR THE WIND RETROFIT OF EXISTING BUILDINGS

(Deleted)

### CHAPTER C1

## GABLE END RETROFIT FOR HIGH-WIND AREAS

*The provisions contained in this appendix are not mandatory unless specifically referenced in the adopting ordinance.*

### SECTION C101 GENERAL

**[BS] C101.1 Purpose.** This chapter provides prescriptive methods for partial structural retrofit of an *existing building* to increase its resistance to out-of-plane wind loads. It is intended for voluntary use and for reference by mitigation programs. The provisions of this chapter do not necessarily satisfy requirements for new construction. Unless specifically cited, the provisions of this chapter do not necessarily satisfy requirements for structural improvements triggered by *addition, alteration, repair, change of occupancy, building relocation* or other circumstances.

**[BS] C101.2 Eligible buildings and gable end walls.** The provisions of this chapter are applicable only to buildings that meet the following eligibility requirements:

1. The building is not more than three stories tall, from adjacent grade to the bottom plate of each gable end wall being retrofitted with this chapter.
2. The building is classified as Occupancy Group R3 or is within the scope of the *International Residential Code*.
3. The structure includes one or more wood-framed gable end walls, either conventionally framed or metal-plate-connected.

In addition, the provisions of this chapter are applicable only to gable end walls that meet the following eligibility requirements:

4. Each gable end wall has or shall be provided with studs or vertical webs spaced 24 inches (610 mm) on center maximum.
5. Each gable end wall has a maximum height of 16 feet (4877 mm).

**[BS] C101.3 Compliance** Eligible gable end walls in eligible buildings may be retrofitted in accordance with this chapter. Other modifications required for compliance with this chapter shall be designed and constructed in accordance with the *International Building Code* or *International Residential Code* provisions for new construction, except as specifically provided for by this chapter.

### SECTION C102 DEFINITIONS

**[BS] C102.1 Definitions.** The following words and terms shall, for the purposes of this chapter, have the meanings shown herein.

**[BS] ANCHOR BLOCK.** A piece of lumber secured to horizontal braces and filling the gap between existing framing members for the purpose of restraining horizontal braces from movement perpendicular to the framing members.

**[BS] COMPRESSION BLOCK.** A piece of lumber used to restrain in the compression mode (force directed toward the interior of the attic) an existing or retrofit stud. It is attached to a horizontal brace and bears directly against the existing or retrofit stud.

**[BS] CONVENTIONALLY FRAMED GABLE END.** A gable end framed with studs whose faces are perpendicular to the gable end wall.

**[BS] GABLE END FRAME.** A factory or site-fabricated frame, installed as a complete assembly that incorporates vertical webs with their faces parallel to the plane of the frame.

**[BS] HORIZONTAL BRACE.** A piece of lumber used to restrain both compression and tension loads applied by a retrofit stud. It is typically installed horizontally on the top of attic floor framing members (truss bottom chords or ceiling joists) or on the bottom of pitched roof framing members (truss top chord or rafters).



**[BS] HURRICANE TIES.** Manufactured metal connectors designed to provide uplift and lateral restraint for roof framing members.

**[BS] NAIL PLATE.** A manufactured metal plate made of galvanized steel with factory-punched holes for fasteners. A nail plate may have the geometry of a strap.

**[BS] RETROFIT.** The voluntary process of strengthening or improving buildings or structures, or individual components of buildings or structures for the purpose of making existing conditions better serve the purpose for which they were originally intended or the purpose that current building codes intend.

**[BS] RETROFIT STUD.** A lumber member used to structurally supplement an existing gable end wall stud or gable end frame web.

**[BS] STUD-TO-PLATE CONNECTOR.** A manufactured metal connector designed to connect studs to plates.

### **SECTION C103 MATERIALS OF CONSTRUCTION**

**[BS] C103.1 Existing materials.** Existing wood materials that will be part of the retrofitting work (such as trusses, rafters, ceiling joists, top plates and wall studs) shall be in sound condition and free from defects or damage that substantially reduces the load-carrying capacity of the member. Any wood materials found to be damaged or deteriorated shall be strengthened or replaced with new materials to provide a net dimension of sound wood equivalent to its undamaged original dimensions.

**[BS] C103.2 New materials.** All new materials shall comply with the standards for those materials as specified in the *International Building Code* or the *International Residential Code*.

**[BS] C103.3 Material specifications for retrofits.** Materials for retrofitting gable end walls shall comply with Table C103.3.

**[BS] TABLE C103.3  
MATERIAL SPECIFICATIONS FOR RETROFITS<sup>a</sup>**

| COMPONENT  | MINIMUM SIZE OR THICKNESS                      | MINIMUM MATERIAL GRADE              | MINIMUM CAPACITY                          |
|--|--|-------------------------------------|---|
| <u>Anchor blocks, compression blocks and horizontal braces</u> | <u>2 × 4 nominal lumber</u>                    | <u>#2 Spruce-Pine-Fir or better</u> | <u>NA</u>                                 |
| <u>Nail plates</u>   | <u>20 gage thickness 8d minimum nail holes</u> | <u>Galvanized sheet steel</u>       | <u>NA</u>                                 |
| <u>Retrofit studs</u>  | <u>2 × 4 nominal lumber</u>                    | <u>#2 Spruce-Pine-Fir or better</u> | <u>NA</u>                                 |
| <u>Gusset angle</u>  | <u>14 gage thickness</u>                       | <u>Galvanized sheet steel</u>       | <u>350 pounds uplift and lateral load</u> |
| <u>Stud-to-plate connector</u>                                 | <u>20 gage thickness</u>                       | <u>Galvanized sheet steel</u>       | <u>500 pounds uplift</u>                  |
| <u>Metal plate connectors, straps and anchors</u>              | <u>20 gage thickness</u>                       | <u>Galvanized sheet steel</u>       | <u>NA</u>                                 |

For SI: 1 pound = 4.4 N.

NA = Not Applicable.

a. Metal plate connectors, nail plates, stud-to-plate connectors, straps and anchors shall be products approved for connecting wood-to-wood or wood-to-concrete as appropriate.

**[BS] C103.4 Twists in straps.** Straps shall be permitted to be twisted or bent where they transition between framing members or connection points. Straps shall be bent only once at a given location though it is permissible that they be bent or twisted at multiple locations along their length.

**[BS] C103.5 Fasteners.** Fasteners shall meet the requirements of Table C103.5, Sections C103.5.1 and C103.5.2, and shall be permitted to be screws or nails meeting the minimum length requirement shown in the figures and specified in the tables of this appendix. Fastener spacing shall meet the requirements of Section C103.5.3.

**[BS] TABLE C103.5  
NAIL AND SCREW REQUIREMENTS**

| FASTENER TYPE | MINIMUM SHANK DIAMETER | MINIMUM HEAD DIAMETER | MINIMUM FASTENER LENGTH |
|---------------|------------------------|-----------------------|-------------------------|
|---------------|------------------------|-----------------------|-------------------------|

|                  |              |             |                                      |
|------------------|--------------|-------------|--------------------------------------|
| #8 screws        | NA           | 0.28 inches | 1 <sup>1</sup> / <sub>4</sub> inches |
| 8d common nails  | 0.131 inches | 0.28 inches | 2 <sup>1</sup> / <sub>2</sub> inches |
| 10d common nails | 0.148 inches | 0.28 inches | 3 inches                             |

For SI: 1 inch = 25.4 mm.

NA = Not Applicable.

**[BS] C103.5.1 Screws.** Unless otherwise indicated in the appendix, screw sizes and lengths shall be in accordance with Table C103.5. Permissible screws include deck screws and wood screws. Screws shall have not less than 1 inch (25 mm) of thread. Fine threaded screws or drywall screws shall not be permitted. Select the largest possible diameter screw such that the shank adjacent to the head fits through the hole in the strap.

**[BS] C103.5.2 Nails.** Unless otherwise indicated in this appendix, nail sizes and lengths shall be in accordance with Table C103.5.

**[BS] C103.5.3 General fastener spacing.** Fastener spacing for shear connections of lumber-to-lumber shall meet the requirements shown in Figure C103.5.3 and the following conditions.

**[BS] C103.5.3.1 General fastener spacing.** Fastener spacing shall meet the following conditions except as provided for in Section C103.5.3.

The distance between fasteners and the edge of lumber that is less than 3<sup>1</sup>/<sub>2</sub> inches deep (89 mm) in the direction of the fastener length shall be not less than 3<sup>3</sup>/<sub>4</sub> inch (19.1 mm).

1. The distance between fasteners and the edge of lumber that is more than 2 inches (51 mm) thick in the direction of the fastener length shall be not less than 1<sup>1</sup>/<sub>2</sub> inch (12.7 mm).
2. The distance between a fastener and the end of lumber shall be not less than 2<sup>1</sup>/<sub>2</sub> inches (64 mm).
3. The distance between fasteners parallel to the grain (center-to-center) shall be not less than 2<sup>1</sup>/<sub>2</sub> inches (64 mm).
4. The distance between fasteners perpendicular to the grain (center-to-center) in lumber that is less than 3<sup>1</sup>/<sub>2</sub> inches (89 mm) deep in the direction of the fastener length shall be 1 inch (25 mm).
5. The distance between fasteners perpendicular to the grain (center-to-center) in lumber that is more than 2 inches (51 mm) thick in the direction of the fastener length shall be 1<sup>1</sup>/<sub>2</sub> inch (12.7 mm).

**[BS] C103.5.3.2 Wood-to-wood connections of two members each 2 inches or less in thickness.** Wood-to-wood connections fastener spacing shall meet the following conditions.

1. The distance between fasteners parallel to grain (center-to-center) shall be not less than 2<sup>1</sup>/<sub>2</sub> inches (64 mm).
2. The distance between fasteners across grain (center-to-center) shall be not less than 1 inch (25 mm).
3. For wood-to-wood connections of lumber at right angles, fasteners shall be spaced not less than 2<sup>1</sup>/<sub>2</sub> inches (64 mm) parallel to the grain and 1 inch (25 mm) perpendicular to the grain in any direction.

**[BS] C103.5.3.3 Metal connectors for wood-to-wood connections.** Metal connectors for wood-to-wood connections shall meet the following conditions.

1. Fastener spacing to edge or ends of lumber shall be as dictated by the prefabricated holes in the connectors and the connectors shall be installed in a configuration that is similar to that shown by the connector manufacturer.
2. Fasteners in 1<sup>1</sup>/<sub>4</sub>-inch-wide (32 mm) metal straps that are installed on the narrow face of lumber shall be a minimum 1<sup>1</sup>/<sub>4</sub> inch (6.4 mm) from either edge of the lumber. Consistent with Section C103.5.3.1, fasteners shall be permitted to be spaced according to the fastener holes fabricated into the strap.
3. Fasteners in metal nail plates shall be spaced not less than 1<sup>1</sup>/<sub>2</sub> inch (12.7 mm) perpendicular to grain and not less than 1<sup>1</sup>/<sub>2</sub> inches (38 mm) parallel to grain.

## **SECTION C104**

### **RETROFITTING GABLE END WALLS TO ENHANCE WIND RESISTANCE**

**[BS] C104.1 General.** These prescriptive methods of retrofitting are intended to increase the resistance of existing gable end construction for out-of-plane wind loads resulting from high-wind events. The ceiling diaphragm shall be comprised of minimum

1/2-inch-thick (12.7 mm) gypsum board, minimum nominal 3/8-inch-thick (9.5 mm) wood structural panels, or plaster. An overview isometric drawing of one type of gable end retrofit to improve wind resistance is shown in Figure C104.1.

**[BS] C104.2 Horizontal braces.** Horizontal braces shall be installed perpendicular to the roof and ceiling framing members at the location of each existing gable end stud greater than 3 feet (91 cm) in length. Unless it is adjacent to an omitted horizontal brace location, horizontal braces shall be minimum 2-inch by 4-inch (38 mm by 89 mm) dimensional lumber as defined in Section C103.3. A single horizontal brace is required at the top and bottom of each gable end stud for Retrofit Configuration A, B, or C. Two horizontal braces are required at the top and bottom of each gable end stud for Retrofit Configuration D. Maximum heights of gable end wall studs and associated retrofit studs for each Retrofit Configuration shall not exceed the values listed in Table C104.2. Horizontal braces shall be oriented with their wide faces across the roof or ceiling framing members, be fastened to not fewer than three framing members, and extend not less than 6 feet (183 cm) measured perpendicularly from the gable end plus 2 1/2 inches (64 mm) beyond the last top chord or bottom chord member (rafter or ceiling joist) from the gable end as shown in Figures C104.2(1), C104.2(2), C104.2(3) and C104.2(4).

**[BS] TABLE C104.2  
STUD LENGTH LIMITATIONS BASED ON EXPOSURE AND DESIGN WIND SPEED**

| <u>EXPOSURE CATEGORY</u> | <u>MAXIMUM 3-SEC GUST BASIC WIND SPEED<sup>a</sup></u> | <u>MAXIMUM HEIGHT OF GABLE END RETROFIT STUD<sup>b</sup></u> |               |               |                       |
|--------------------------|--|--|---------------|---------------|-----------------------|
| <u>C</u>                 | <u>140</u>   | <u>8'-0"</u>   | <u>11'-3"</u> | <u>14'-9"</u> | <u>16'-0"</u>         |
| <u>C</u>                 | <u>150</u>   | <u>7'-6"</u>   | <u>10'-6"</u> | <u>13'-6"</u> | <u>16'-0"</u>         |
| <u>C</u>                 | <u>165</u>   | <u>7'-0"</u>   | <u>10'-0"</u> | <u>12'-3"</u> | <u>16'-0"</u>         |
| <u>C</u>                 | <u>180</u>   | <u>7'-0"</u>   | <u>10'-0"</u> | <u>12'-3"</u> | <u>16'-0"</u>         |
| <u>C</u>                 | <u>190</u>   | <u>6'-6"</u>   | <u>8'-9"</u>  | <u>11'-0"</u> | <u>16'-0"</u>         |
| <u>B</u>                 | <u>140</u>   | <u>8'-0"</u>   | <u>12'-3"</u> | <u>16'-0"</u> | <u>NR<sup>c</sup></u> |
| <u>B</u>                 | <u>150</u>   | <u>8'-0"</u>   | <u>11'-3"</u> | <u>14'-9"</u> | <u>16'-0"</u>         |
| <u>B</u>                 | <u>165</u>   | <u>8'-0"</u>   | <u>11'-3"</u> | <u>14'-9"</u> | <u>16'-0"</u>         |
| <u>B</u>                 | <u>180</u>   | <u>7'-6"</u>   | <u>10'-6"</u> | <u>13'-6"</u> | <u>16'-0"</u>         |
| <u>B</u>                 | <u>190</u>   | <u>7'-0"</u>   | <u>10'-0"</u> | <u>12'-3"</u> | <u>16'-0"</u>         |
|                          | <u>Retrofit Configuration</u>                          | <u>A</u>   | <u>B</u>      | <u>C</u>      | <u>D</u>              |

For SI: 1 inch = 25.4 mm, 1 foot = 304.8 mm.

NR = Not Required.

- a. Interpolation between given wind speeds is not permitted.
- b. Existing gable end studs less than or equal to 3 feet 0 inches in height shall not require retrofitting.
- c. Configuration C is acceptable to 16 feet 0 inches maximum height.

**[BS] C104.2.1 Existing gable end studs.** If the spacing of existing vertical gable end studs is greater than 24 inches (64 mm), a new stud and corresponding horizontal braces shall be installed such that the maximum spacing between existing and added studs shall be not greater than 24 inches (64 mm). Additional gable end wall studs shall not be required at locations where their length would be 3 feet (914 mm) or less. Each end of each required new stud shall be attached to the existing roofing framing members (truss top chord or rafter and truss bottom chord or ceiling joist) using not fewer than two 3-inch (76 mm) toenail fasteners (#8 wood screws or 10d nails) and a metal connector with minimum uplift capacity of 175 pounds (778 N), or nail plates with not fewer than four 1 1/4-inch-long (32 mm) fasteners (No. 8 wood screws or 8d nails).

**[BS] C104.2.2 Main method of installation.** Each horizontal brace shall be fastened to each existing roof or ceiling member that it crosses using three 3-inch-long (76 mm) fasteners (No. 8 wood screws or 10d nails) as indicated in Figure C104.2(1) and Figure C104.2(3) for trusses and Figure C104.2(2) and Figure C104.2(4) for conventionally framed gable end walls. Alternative methods for providing horizontal bracing of the gable end studs as provided in Sections C104.2.3 through C104.2.9 shall be permitted.

**[BS] C104.2.3 Omitted horizontal brace.** Where conditions exist that prevent installation in accordance with Section C104.2.2, horizontal braces shall be permitted to be omitted for height limitations corresponding to Retrofit Configurations A and B as defined in Table C104.2 provided that installation is as indicated in Figure C104.2.3 and provided that all of the following conditions are met. This method is not permitted for Retrofit Configurations C or D.

1. There shall be not fewer than two horizontal braces on each side of an omitted horizontal brace or not fewer than one horizontal brace if it is the end horizontal brace. Omitted horizontal braces must be separated by not fewer than two horizontal braces even if that location is composed of two retrofit studs and two horizontal braces.
2. Horizontal braces adjacent to the omitted horizontal brace shall be 2-inch by 6-inch (38 mm by 140 mm) lumber, shall butt against the existing studs, and shall be fastened to each existing roof or ceiling member crossed using three 3-inch-long (76 mm) fasteners (No. 8 wood screws or 10d nails). For Retrofit Configuration B, four fasteners shall be required on not fewer than one of the connections between the horizontal brace and the existing roof and ceiling framing members. Fasteners shall be spaced a not less than  $\frac{3}{4}$  inch (19.1 mm) from the edges of the horizontal braces and not less than  $1\frac{3}{4}$  inches (44 mm) from adjacent fasteners.
3. Where the existing studs on each side of an omitted horizontal brace have their wide face perpendicular to the gable end wall, the retrofit studs at those locations and the retrofit stud at the omitted horizontal brace locations shall extend not less than  $3\frac{3}{4}$  inches (95 mm) beyond the interior edge of the existing studs for both Retrofit Configurations A and B. The edges of the three retrofit studs facing towards the interior of the attic shall be aligned such that they are the same distance from the gable end wall.
4. Retrofit studs shall be fastened to existing studs in accordance with Section C104.3.
5. Retrofit studs adjacent to the omitted horizontal brace shall be fastened to the horizontal brace using straps in accordance with Table C104.4.1 consistent with the size of the retrofit stud. The method applicable to Table C104.4.2 is not permitted.
6. A strong back made of minimum of 2-inch by 8-inch (38 mm by 184 mm) nominal lumber shall be placed parallel to the gable end and shall be located on and span between horizontal braces on the two sides of the omitted horizontal brace and shall extend beyond each horizontal brace by not less than  $2\frac{1}{2}$  inches (64 mm). The strong back shall be butted to the three retrofit studs. The strong back shall be attached to each of the horizontal braces on which it rests with five 3-inch-long (76 mm) fasteners (#8 screws or 8d nails). The fasteners shall have a minimum  $\frac{3}{4}$ -inch (19.1 mm) edge distance and a minimum  $2\frac{1}{2}$ -inch (64 mm) spacing between fasteners. Additional compression blocks shall not be required at locations where a strong back butts against a retrofit stud.
7. The retrofit stud at the location of the omitted horizontal braces shall be fastened to the strong back using a connector with minimum uplift capacity of 800 pounds (3559 N) and installed such that this capacity is oriented in the direction perpendicular to the gable end wall.
8. The use of shortened horizontal braces using the alternative method of Section C104.2.5 is not permitted for horizontal braces adjacent to the omitted horizontal braces.
9. Horizontal braces shall be permitted to be interrupted in accordance with Section C104.2.8.

**[BS] C104.2.4 Omitted horizontal brace and retrofit stud.** Where conditions exist that prevent installation in accordance with Section C104.2.2 or C104.2.3, then retrofit studs and horizontal braces shall be permitted to be omitted from those locations by installation of ladder assemblies for Retrofit Configurations A and B as defined in Table C104.2 provided that all of the following conditions are met. This method is not permitted for Retrofit Configurations C or D.

1. Not more than two ladder assemblies are permitted on a single gable end.
2. There shall be not fewer than two retrofit studs and horizontal brace assemblies on either side of the locations where the retrofit studs and horizontal bracing members are omitted (two ladder braces shall not bear on a single retrofit stud).
3. Where the existing studs on each side of an omitted horizontal brace have their wide face parallel to the gable end wall the retrofit studs at those locations and the retrofit stud at the omitted horizontal brace locations shall be 2-inch by 6-inch (38 mm by 180 mm) nominal lumber for Retrofit Configuration A and 2-inch by 8-inch (38 mm by 184 mm) lumber for Retrofit Configuration B.
4. Horizontal braces adjacent to the omitted horizontal brace shall be 2-inch by 6-inch (38 mm by 180 mm) nominal lumber and be fastened to each existing roof or ceiling member crossed using three 3-inch-long (76 mm) fasteners (#8 wood screws or 10d nails) as indicated in Figures C104.2(1) and C104.2(3) for gable end frames and Figures C104.2(2) and C104.2(4) for conventionally framed gable end walls. For Retrofit Configuration B, four fasteners shall be required on one of the connections between the horizontal brace and the existing roof and ceiling framing members.

5. Ladder rungs shall be provided across the location of the omitted retrofit studs as indicated in Figure C104.2.4(1) for gable end frames and Figure C104.2.4(2) for conventionally framed gable end walls.
6. Ladder rungs shall be minimum 2-inch by 4-inch (38 mm by 89 mm) lumber oriented with their wide face horizontal and spaced not greater than 16 inches (406 mm) on center vertically.
7. Where ladder rungs cross wall framing members they shall be connected to the wall framing members with a metal connector with a minimum capacity of 175 pounds (778 N) in the direction perpendicular to the gable end wall.
8. Notching of the ladder rungs shall not be permitted unless the net depth of the framing member is not less than 3<sup>1</sup>/<sub>2</sub> inches (89 mm).

**[BS] C104.2.5 Short horizontal brace.** Where conditions exist that prevent installation in accordance with Section C104.2.2, C104.2.3 or C104.2.4, the horizontal braces shall be permitted to be shortened provided that installation is as indicated in Figure C104.2.5 and all of the following conditions are met.

1. The horizontal brace shall be installed across not fewer than two framing spaces, extend not less than 4 feet (1220 mm) from the gable end wall plus 2<sup>1</sup>/<sub>2</sub> inches (64 mm) beyond the farthest roof or ceiling framing member from the gable end, and be fastened to each existing framing member with three 3-inch-long (76 mm) fasteners (#8 wood screws or 10d nails).
2. An anchor block shall be fastened to the side of the horizontal brace in the second framing space from the gable end wall as shown in Figure C104.2.5. The anchor block lumber shall have a minimum edge thickness of 1<sup>1</sup>/<sub>2</sub> inches (38 mm) and the depth shall be at a minimum the depth of the existing roof or ceiling framing member. Six 3-inch-long (76 mm) fasteners (#8 wood screws or 10d nails) shall be used to fasten the anchor block to the side of the horizontal brace.
3. The anchor block shall extend into the space between the roof or ceiling framing members not less than one-half the depth of the existing-framing members at the location where the anchor block is installed. The anchor block shall be installed tightly between the existing framing members such that the gap at either end shall not exceed 1/8 inch (3.2 mm).
4. The use of omitted horizontal braces using the method of Section C104.2.3 adjacent to a short horizontal brace as defined in this section is not permitted.

**[BS] C104.2.6 Installation of horizontal braces onto webs of trusses.** Where existing conditions preclude installation of horizontal braces on truss top or bottom chords they shall be permitted to be installed on truss webs provided that all of the following conditions are met.

1. Horizontal braces shall be installed as close to the top or bottom chords as practical without altering the truss or any of its components and not more than three times the depth of the truss member to which it would ordinarily be attached.
2. A racking block, comprised of an anchor block meeting the definition of “Anchor block” in Section C102 or comprised of minimum 1<sup>5</sup>/<sub>32</sub>-inch (12 mm) plywood or 7/16-inch (11.1 mm) oriented strand board (OSB), shall be fastened to the horizontal brace in the second framing space from the gable end wall. The racking block shall extend toward the roof or ceiling diaphragm so that the edge of the racking block closest to the diaphragm is within one-half the depth of the existing framing member from the diaphragm surface. The racking block shall be attached to horizontal braces using six fasteners (No. 8 wood screws or 10d nails) of sufficient length to provide 1<sup>1</sup>/<sub>2</sub> inches (38 mm) of penetration into the horizontal brace.
3. Racking blocks shall be permitted to be fastened to any face or edge of horizontal braces between each web or truss vertical posts to which a horizontal brace is attached. Racking blocks shall be permitted to be on alternate sides of horizontal braces. Racking blocks shall be installed tightly between the lumber of truss members or truss plates such that the gap at either end shall be not greater than 1/8 inch (3.2 mm).

**[BS] C104.2.7 Alternative method of installation of horizontal braces at truss ridges.** Where conditions exist that limit or restrict installation of horizontal braces near the peak of the roof, ridge ties shall be added to provide support for the required horizontal brace. The top of additional ridge tie members shall be installed not greater than 16 inches (406 mm) below the existing ridge line or 4 inches (102 mm) below impediments. A minimum 2-inch by 4-inch (38 mm by 89 mm) nominal member shall be used for each ridge tie, and fastening shall consist of two 3-inch-long (76 mm) wood screws, four 3-inch-long (76 mm) 10d nails or two 3<sup>1</sup>/<sub>2</sub>-inch-long (89 mm) 16d nails driven through and clinched at each top chord or web member intersected by the ridge tie as illustrated in Figure C104.2.7.

**[BS] C104.2.8 Interrupted horizontal braces.** Where conditions exist that prevent the installation of a continuous horizontal brace then horizontal braces shall be permitted to be interrupted using the methods shown in Figures C104.2.8(1), C104.2.8(2), and C104.2.8(3). For interruptions that occur in the attic framing space closest to the gable end, nine 3-inch (76 mm) fasteners

shall be used to connect each section of the interrupted horizontal braces. For interruptions that occur in the second attic space from the gable end, six 3-inch (76 mm) fasteners shall be used to connect each section of the interrupted horizontal braces. For interruptions that occur in the attic framing space farthest from the gable end, three 3-inch (76 mm) fasteners shall be used to connect each section of the interrupted horizontal braces. Horizontal braces shall be continued far enough to allow connections to three existing roof framing members as shown in Figure C104.2.8(1), C104.2.8(2) or C104.2.8(3). Fasteners shall be spaced in accordance with Section C103.5.3. Horizontal braces shall be the same width and depth as required for an uninterrupted member.

**[BS] C104.2.9 Piggyback gable end frames.** Piggyback gable end frames (gable end frames built in two sections one above the other) shall be permitted to be retrofitted if either of the following cases is true:

1. The existing studs in both the upper gable end frames and the lower gable end frames to which wall sheathing, panel siding, or other wall covering are attached are sufficiently in line that retrofit studs can be installed and connections made between the two with retrofit stud(s).
2. Existing studs in the upper frame are not sufficiently in line with the studs in the frame below and the existing studs in the upper frame are 3 feet (91 cm) or shorter.

For Condition 1 both the lower stud and the upper stud shall be retrofitted using the methods of Section C104.2. For Condition 2 the retrofit stud shall be connected to the lower studs using the methods of Section C104.2 and be continuous from the bottom horizontal brace to the top horizontal brace. Connection is not required between the retrofit stud and the upper stud. In both conditions the bottom chord of the piggyback truss section shall be fastened to each retrofit stud using a connector with minimum axial capacity of 175 pounds (778 N).

**[BS] C104.3 Retrofit studs.** Retrofit studs shall be installed in accordance with Section C104.3.1 using one of the five methods of Sections C104.3.2, C104.3.3, C104.3.4, C104.3.5 or C104.3.6. Figure C104.3 shows these methods of installation. For the Retrofit Configuration obtained from Table C104.2, the size of retrofit studs shall be as indicated in Table C104.4.1 or Table C104.4.2. Retrofit studs shall extend from the top of the lower horizontal brace to the bottom of the upper horizontal brace except that a maximum gap of  $\frac{1}{8}$  inch (3.2 mm) is permitted at the bottom and  $\frac{1}{2}$  inch (12.7 mm) at the top. Where wall sheathing, panel siding or other wall covering is fastened to a conventionally framed gable end, retrofit studs shall be applied in accordance with Section C104.2.1.

**[BS] C104.3.1 Fastening.** Where nail plates are not used, retrofit studs shall be attached to existing studs using 3-inch (76 mm) fasteners at not greater than 6 inches (152 mm) on center but not closer than  $2\frac{1}{2}$  inches (64 mm) on center with fasteners not closer to ends of members than  $2\frac{1}{2}$  inches (64 mm).

**[BS] C104.3.2 Method #1: Face-to-edge or face-to-face method.** Retrofit studs shall be installed immediately adjacent to existing gable end wall studs as indicated in Figure C104.3(a). The retrofit studs shall overlap the edge or side of the existing stud by not less than  $1\frac{1}{4}$  inches (32 mm). Fasteners shall be installed as specified in Section C104.3.1.

**[BS] C104.3.3 Method #2: Face-to-face offset method.** Retrofit studs shall be installed against the face of existing studs as indicated in Figure C104.3(b) such that the faces overlap not less than  $1\frac{1}{2}$  inches (38 mm) and the edge distance to fasteners is not less than  $\frac{3}{4}$  inch (19.1 mm). Fasteners shall be installed as specified in Section C104.3.1.

**[BS] C104.3.4 Method #3: Butted retrofit stud method.** Provided that all of the following fastening conditions are met, retrofit studs shall be permitted to be butted by their edge to existing studs with the addition of nail plates as indicated in Figure C104.3(c) and Figure C104.3.4.

1. The narrow edge of retrofit studs shall be installed against the narrow or the wide face of existing studs.
2. Not fewer than two nail plates shall be used.
3. Fasteners used to secure nail plates to studs shall be a minimum  $1\frac{1}{4}$  inches (32 mm) long (#8 wood screws or 8d nails).
4. Fasteners placed in nail plates shall have a minimum end distance of  $2\frac{1}{2}$  inches (64 mm) for both studs and a maximum end distance of 6 inches (152 mm) from the ends of the shorter stud.
5. Fasteners shall have a minimum  $\frac{1}{2}$ -inch (12.7 mm) edge distance. Fasteners shall be placed not greater than  $1\frac{1}{2}$  inches (38 mm) from the abutting vertical edges of existing studs and retrofit studs.
6. There shall be at least three fasteners through nail plates into all existing and retrofit studs to which the nail plate is attached.
7. Nail plates with three fasteners onto a single existing or retrofit stud shall be spaced not greater than 15 inches (38 cm) on center.
8. Nail plates with more than three fasteners onto a single existing or retrofit stud shall be spaced not greater than 20 inches (51 cm) on center.

9. Fasteners used to secure nail plates shall be spaced vertically not less than 1½ inches (38 mm) on center. Staggered fasteners used to secure nail plates shall be spaced horizontally not less than ½ inch (12.7 mm).

**[BS] C104.3.5 Method #4: Offset retrofit stud method.** Retrofit studs may be offset from existing studs by use of nail plates as shown in Figure C104.3(d) such that the vertical corner of a retrofit stud shall align with the vertical corner of an existing stud as indicated in Figure C104.3(d) and Figure C104.3.4, and the fastening conditions of Section C104.3.4 are met.

**[BS] C104.3.6 Method #5: Nailer with retrofit stud method.** Retrofit studs and existing studs shall be permitted to be connected using noncontinuous 2-inch by 4-inch (38 mm by 89 mm) nailers as indicated in Figure C104.3(e) provided that the following conditions are met.

1. Both the existing stud and the retrofit stud shall be butted to nailers and both shall be fastened to the nailer with 3-inch-long (76 mm) fasteners (#8 wood screws or 8d nails). Fasteners connecting each stud to the nailer shall be spaced 6 inches (152 mm) o.c.
2. Fasteners into nailers from any direction shall be offset vertically by not less than 2½ inches (64 mm).
3. Fasteners into nailers shall be not less than 2½ inches (64 mm) but not more than 6 inches (152 mm) from the end of the shorter of the existing stud and retrofit stud to which they are fastened.

**[BS] C104.3.7 Reduced depth of retrofit studs.** Retrofit studs may be reduced in depth by notching, tapering or other methods at any number of locations along their length provided that all of the following conditions are met:

1. Retrofit studs to be reduced in depth shall be sized such that the remaining minimum depth of member at the location of the notch (including cross-cut kerfs) shall be not less than that required by Table C104.4.1 or Table C104.4.2.
2. Reduced in-depth retrofit stud shall not be spliced within 12 inches (30 cm) of the location of notches. Splice members shall not be notched.
3. The vertical extent of notches shall not exceed 12 inches (30 cm) as measured at the depth of location of reduced depth.
4. A reduced in-depth retrofit stud member shall be fastened to the side of the existing gable end wall studs in accordance with Section C104.3.1. Two additional 3-inch (76 mm) fasteners (#8 wood screws or 10d nails) shall be installed on each side of notches in addition to those required by Section C104.3.1.

**[BS] C104.3.8 Retrofit stud splices.** Retrofit studs greater than 8 feet (244 cm) in height may be field spliced in accordance with Figure C104.3.8.

**[BS] C104.4 Connection between horizontal braces and retrofit studs.** Connections between horizontal braces and retrofit studs shall comply with Section C104.4.1 or C104.4.2. Each retrofit stud shall be connected to the top and bottom horizontal brace members with a minimum 20-gage 1¼-inch-wide (32 mm) flat or coil metal strap with prepunched holes for fasteners. Straps shall be fastened with 1¼-inch-long (32 mm) fasteners (#8 wood screws or 8d nails) with the number of fasteners as indicated in Table C104.4.1 and Table C104.4.2. Fasteners shall be not closer to the end of lumber than 2½ inches (64 mm).

**[BS] C104.4.1 L-bent strap method.** Retrofit studs shall be connected to horizontal braces or to strong backs in accordance with Figure C104.2(1), C104.2(2) or C104.2.3, and shall comply with the following conditions.

1. A strap shall be applied to the edges of a retrofit stud nearest the gable end wall and to the face of horizontal braces using at each end of the strap the number of fasteners specified in Table C104.4.1. Straps shall be long enough so that each strap extends sufficient distance onto the vertical face of the retrofit stud that the fastener closest to the ends of the studs is not less than 2½ inches (64 mm) from the end of the stud. Straps shall be permitted to be twisted to accommodate the transition between the tops of retrofit studs and horizontal bracings following roof pitches.
2. Compression blocks shall be installed on the horizontal braces directly against either the existing vertical gable end wall stud or the retrofit stud. Figure C104.2(1) (trusses) and Figure C104.2(2) (conventionally framed) show the installation of the compression block against the existing vertical gable end wall stud with the strap from the retrofit stud running beside the compression block. Compression blocks shall be permitted to be placed over straps. Compression blocks shall be fastened to the horizontal braces with not fewer than the minimum number of 3-inch-long (76 mm) fasteners (#8 wood screws or 10d nails) specified in Table C104.4.1. End and edge distances for fasteners shall be in accordance with Section C103.5.3.

**[BS] TABLE C104.4.1  
ELEMENT SIZING AND SPACING FOR L-BENT RETROFIT METHOD**

| RETROFIT ELEMENTS                            | RETROFIT CONFIGURATION |       |       |              |
|--|------------------------|-------|-------|--------------|
|  | A                      | B     | C     | D            |
| Minimum size and number of Horizontal Braces | 2 × 4                  | 2 × 4 | 2 × 4 | 2 each 2 × 4 |

|   |              |              |              |                        |
|---|--------------|--------------|--------------|------------------------|
| Minimum size and number of Retrofit Studs   | <u>2 × 4</u> | <u>2 × 6</u> | <u>2 × 8</u> | <u>2 each 2 × 8</u>    |
| Minimum number of fasteners connecting each end of straps to Retrofit Studs or to Horizontal Braces #8 screws or 10d nails 1 <sup>1</sup> / <sub>4</sub> " long | <u>6</u>     | <u>9</u>     | <u>12</u>    | <u>8 on each strap</u> |
| Minimum number of fasteners to connect Compression Blocks to Horizontal Braces #8 screws or 10d nails 3" long   | <u>6</u>     | <u>8</u>     | <u>10</u>    | <u>12</u>              |

For SI: 1 inch = 25.4 mm, 1 foot = 304.8 mm.

**[BS] C104.4.2 U-bent strap method.** Retrofit studs shall be connected to horizontal braces in accordance with Figure C104.2(3) or C104.2(4), shall be limited to Retrofit Configurations A and B as defined in Table C104.2, and shall comply with the following conditions.

1. Straps of sufficient length to meet the requirements for the number of fasteners in accordance with Table C104.4.2 and meet the end distance requirements of Section C103.5.3 shall be shaped around retrofit studs and fastened to the edges of horizontal braces. Straps shall wrap the back edge of the retrofit stud snugly with a maximum gap of <sup>1</sup>/<sub>4</sub> inch (6.4 mm). Rounded bends of straps shall be permitted. One fastener shall be installed that connects each strap to the side of the associated retrofit stud.
2. The horizontal brace shall butt snugly against the retrofit stud with a maximum gap of <sup>1</sup>/<sub>4</sub> inch (6.4 mm).
3. Straps shall be permitted to be twisted to accommodate the transition between the tops of retrofit studs and horizontal braces that follow the roof pitch.

**[BS] TABLE C104.4.2  
ELEMENT SIZING AND SPACING FOR U-BENT RETROFIT METHOD**

| RETROFIT ELEMENTS   | RETROFIT CONFIGURATION |              |              |                                |
|---|------------------------|--------------|--------------|--------------------------------|
|   | A                      | B            | C            | D                              |
| Minimum size and number of Horizontal Braces  | <u>2 × 4</u>           | <u>2 × 4</u> | <u>2 × 4</u> | <u>2 each 2 × 4</u>            |
| Minimum size and number of Retrofit Studs   | <u>2 × 4</u>           | <u>2 × 6</u> | <u>2 × 8</u> | <u>2 each 2 × 8</u>            |
| Minimum number of fasteners connecting Straps to each edge of Horizontal Braces #8 screws or 10d nails 1 <sup>1</sup> / <sub>4</sub> " long | <u>6</u>               | <u>7</u>     | <u>7</u>     | <u>6 on each side of strap</u> |

For SI: 1 inch = 25.4 mm, 1 foot = 304.8 mm.

**[BS] C104.5 Connection of gable end wall to wall below.** The bottom chords or bottom members of wood-framed gable end walls shall be attached to the wall below using one of the methods prescribed in Section C104.5.1 or C104.5.2. The particular method chosen shall correspond to the framing system and type of wall construction encountered.

**[BS] C104.5.1 Gable end frame.** The bottom chords of the gable end frame shall be attached to the wall below using gusset angles. Not fewer than two fasteners shall be installed into the bottom chord. The gusset angles shall be installed throughout the portion of the gable end where the gable end wall height is greater than 3 feet (91 cm) at the spacing specified in Table C104.5.1. Connection to the wall below shall be by one of the following methods:

1. For a wood-frame wall below, not fewer than two fasteners shall be installed. The fasteners shall be of the same diameter and style specified by the gusset angle manufacturer and sufficient length to extend through the double top plate of the wall below.
2. For a concrete or masonry wall below without a sill plate, the type and number of fasteners into the wall shall be consistent with the gusset angle manufacturer's specifications for fasteners installed in concrete or masonry.
3. For a concrete or masonry wall below with a 2x sill plate, the fasteners into the wall below shall be of the diameter and style specified by the gusset angle manufacturer for concrete or masonry connections; but, long enough to pass through the wood sill plate and provide the required embedment into the concrete or masonry below. Alternatively, the gusset angle can be anchored to the sill plate using four each 1<sup>1</sup>/<sub>2</sub>-inch-long (38 mm) fasteners of the same type as specified by the gusset angle manufacturer for wood connections, provided that the sill plate is anchored to the wall on each side



of the gusset angle by a  $\frac{1}{4}$ -inch-diameter (6.4 mm) masonry screw with  $2\frac{3}{4}$  inches (70 mm) of embedment into the concrete or masonry wall. A  $\frac{1}{4}$ -inch (6.4 mm) washer shall be placed under the heads of the masonry screws.

**[BS] TABLE C104.5.1  
SPACING OF GUSSET ANGLES**

| <u>EXPOSURE CATEGORY</u> | <u>BASIC WIND SPEED (mph)</u> | <u>SPACING OF GUSSET ANGLES (inches)</u> |
|--------------------------|-------------------------------|--|
| <u>C</u>                 | <u>140</u>                    | <u>38</u>                                |
| <u>C</u>                 | <u>150</u>                    | <u>32</u>                                |
| <u>C</u>                 | <u>165</u>                    | <u>28</u>                                |
| <u>C</u>                 | <u>180</u>                    | <u>24</u>                                |
| <u>C</u>                 | <u>190</u>                    | <u>20</u>                                |
| <u>B</u>                 | <u>140</u>                    | <u>48</u>                                |
| <u>B</u>                 | <u>150</u>                    | <u>40</u>                                |
| <u>B</u>                 | <u>165</u>                    | <u>36</u>                                |
| <u>B</u>                 | <u>180</u>                    | <u>30</u>                                |
| <u>B</u>                 | <u>190</u>                    | <u>26</u>                                |

For SI: 1 inch = 25.4 mm, 1 mile per hour = 0.447 m/s.

**[BS] C104.5.2 Conventionally framed gable end wall.** Each stud in a conventionally framed gable end wall, throughout the length of the gable end wall where the wall height is greater than 3 feet (914 mm), shall be attached to the bottom or sill plate using a stud to plate connector with minimum uplift capacity of 175 pounds (778 N). The bottom or sill plate shall then be connected to the wall below using one of the following methods:

1. For a wood frame wall below, the sill or bottom plate shall be connected to the top plate of the wall below using  $\frac{1}{4}$ -inch-diameter (6.4 mm) lag bolt fasteners of sufficient length to penetrate the bottom plate of the upper gable end wall and extend through the bottom top plate of the wall below. A washer sized for the diameter of the lag bolt shall be placed under the head of each lag bolt. The fasteners shall be installed at the spacing indicated in Table C104.5.2.
2. For a concrete or masonry wall below, the sill or bottom plate shall be connected to the concrete or masonry wall below using  $\frac{1}{4}$ -inch-diameter (6.4 mm) concrete or masonry screws of sufficient length to provide  $2\frac{3}{4}$  inches (70 mm) of embedment into the top of the concrete or masonry wall. A washer sized for the diameter of the lag bolt shall be placed under the head of each lag bolt. The fasteners shall be installed at the spacing indicated in Table C104.5.2.

**[BS] TABLE C104.5.2  
SPACING OF LAG OR MASONRY SCREWS USED TO CONNECT SILL PLATE OF GABLE END WALL TO TOP OF THE WALL BELOW**

| <u>EXPOSURE CATEGORY</u> | <u>BASIC WIND SPEED (mph)</u> | <u>SPACING OF LAG OR MASONRY SCREWS (inches)</u> |
|--------------------------|-------------------------------|--|
| <u>C</u>                 | <u>140</u>                    | <u>19</u>  |
| <u>C</u>                 | <u>150</u>                    | <u>16</u>  |
| <u>C</u>                 | <u>165</u>                    | <u>14</u>  |
| <u>C</u>                 | <u>180</u>                    | <u>14</u>  |
| <u>C</u>                 | <u>190</u>                    | <u>10</u>  |
| <u>B</u>                 | <u>140</u>                    | <u>24</u>  |
| <u>B</u>                 | <u>150</u>                    | <u>20</u>  |

|          |            |           |
|----------|------------|-----------|
| <u>B</u> | <u>165</u> | <u>18</u> |
| <u>B</u> | <u>180</u> | <u>15</u> |
| <u>B</u> | <u>190</u> | <u>13</u> |

For SI: 1 inch = 25.4 mm, 1 mile per hour = 0.447 m/s.

For SI: 1 inch = 25.4 mm, 1 mile per hour = 0.447 m/s.

## CHAPTER C2

# ROOF DECK FASTENING FOR HIGH-WIND AREAS

### SECTION C201 GENERAL

**[BS] C201.1 Purpose.** This chapter provides prescriptive methods for partial structural retrofit of an *existing building* to increase its resistance to wind loads. It is intended for voluntary use where the ultimate design wind speed,  $V_{ult}$ , determined in accordance with Figure 1609.3(1) of the *International Building Code* exceeds 130 mph (58 m/s) and for reference by mitigation programs. The provisions of this chapter do not necessarily satisfy requirements for new construction. Unless specifically cited, the provisions of this chapter do not necessarily satisfy requirements for structural improvements triggered by *addition, alteration, repair, change of occupancy, building relocation* or other circumstances.

**[BS] C201.2 Eligible conditions.** The provisions of this chapter are applicable only to buildings that meet either of the following eligibility requirements:

1. Buildings assigned to *Risk Category I* or *II* in accordance with Table 1604.5 of the *International Building Code*.
2. Buildings within the scope of the *International Residential Code*.

### SECTION C202 ROOF DECK ATTACHMENT FOR WOOD ROOFS

**[BS] C202.1 Roof decking attachment for one- and two-family dwellings.** For one- and two-family dwellings, fastening shall be in accordance with Section C202.1.1 or C202.1.2 as appropriate for the existing construction. The diameter of 8d nails shall be not less than 0.131 inch (3 mm) and the length shall be not less than  $2\frac{1}{4}$  inches (57 mm) to qualify for the provisions of this section for existing nails regardless of head shape or head diameter.

**[BS] C202.1.1 Sawn lumber or wood plank roofs.** Roof decking consisting of sawn lumber or wood planks up to 12 inches (30 cm) wide and secured with not fewer than two nails (minimum size 8d) to each roof framing member it crosses shall be deemed to be sufficiently connected. Sawn lumber or wood plank decking secured with smaller fasteners than 8d nails or with fewer than two nails (minimum size 8d) to each framing member it crosses shall be deemed sufficiently connected if fasteners are added such that two clipped head, round head or ring shank nails (minimum size 8d) are in place on each framing member the nail crosses.

**[BS] C202.1.2 Wood structural panel roofs** For roof decking consisting of wood structural panels, fasteners and spacings required in Table C202.1.2 shall be deemed to comply with the requirements of Section 706.3.

Supplemental fasteners as required by Table C202.1.2 shall be 8d ring shank nails with round heads and the following minimum dimensions:

1. 0.113-inch-nominal (3 mm) shank diameter.
2. Ring diameter not less than 0.012 inch (0.3 mm) greater than shank diameter.
3. 16 to 20 rings per inch.
4. A minimum 0.280-inch (7 mm) full round head diameter.
5. Ring shank to extend not less than  $1\frac{1}{2}$  inches (38 mm) from the tip of the nail.
6. Minimum  $2\frac{1}{4}$ -inch (57 mm) nail length.

**[BS] TABLE C202.1.2**  
**SUPPLEMENT FASTENERS AT PANEL EDGES AND INTERMEDIATE FRAMING**

| <u>EXISTING FASTENERS</u> | <u>EXISTING FASTENER SPACING (EDGE OR INTERMEDIATE SUPPORTS)</u> | <u>MAXIMUM SUPPLEMENTAL FASTENER SPACING FOR 130 MPH &lt; <math>V_{ult}</math> ≤ 140 MPH</u> | <u>MAXIMUM SUPPLEMENTAL FASTENER SPACING FOR INTERIOR ZONE<sup>c</sup> LOCATIONS FOR MPH <math>V_{ult}</math> &gt; 140 MPH AND EDGE ZONES NOT COVERED BY THE COLUMN TO THE RIGHT</u> | <u>EDGE ZONE<sup>d</sup> FOR <math>V_{ult}</math> &gt; 160 MPH AND EXPOSURE C, OR <math>V_{ult}</math> &gt; 180 MPH AND EXPOSURE B</u> |
|---------------------------|--|--|--|--|
|                           |  |  |  |  |

|   |                             |                            |  |  |
|---|-----------------------------|----------------------------|--|--|
| <u>Staples or 6d</u>                                  | <u>Any</u>                  | <u>6" o.c.<sup>b</sup></u> | <u>6" o.c.<sup>b</sup></u>   | <u>4" o.c.<sup>b</sup> at panel edges and<br/>4" o.c.<sup>b</sup> at intermediate<br/>supports</u> |
| <u>8d clipped head or round head<br/>smooth shank</u> | <u>6" o.c. or less</u>      | <u>None necessary</u>      | <u>None necessary along<br/>edges of panels but 6"<br/>o.c.<sup>b</sup> at intermediate<br/>supports of panel</u>  | <u>4" o.c.<sup>a</sup> at panel edges and<br/>4" o.c.<sup>a</sup> at intermediate<br/>supports</u> |
| <u>8d clipped head or round head<br/>ring shank</u>   | <u>6" o.c. or less</u>      | <u>None necessary</u>      | <u>None necessary</u>  | <u>4" o.c.<sup>a</sup> at panel edges and<br/>4" o.c.<sup>a</sup> at intermediate<br/>supports</u> |
| <u>8d clipped head or round head<br/>smooth shank</u> | <u>Greater than 6" o.c.</u> | <u>6" o.c.<sup>a</sup></u> | <u>6" o.c.<sup>a</sup> along panel edges<br/>and 6" o.c.<sup>b</sup> at<br/>intermediate supports of<br/>panel</u> | <u>4" o.c.<sup>a</sup> at panel edges and<br/>4" o.c.<sup>a</sup> at intermediate<br/>supports</u> |
| <u>8d clipped head or round head<br/>ring shank</u>   | <u>Greater than 6" o.c.</u> | <u>6" o.c.<sup>a</sup></u> | <u>6" o.c.<sup>a</sup></u>   | <u>4" o.c.<sup>a</sup> at panel edges and<br/>4" o.c.<sup>a</sup> at intermediate<br/>supports</u> |

For SI: 1 inch = 25.4 mm; 1 foot = 304.8 mm; 1 mile per hour = 0.447 m/s.

a. Maximum spacing determined based on existing fasteners and supplemental fasteners.

b. Maximum spacing determined based on supplemental fasteners only.

c. Interior zone = sheathing that is not located within 4 feet of the perimeter edge of the roof or within 4 feet of each side of a ridge.

d. Edge zone = sheathing that is located within 4 feet of the perimeter edge of the roof and within 4 feet of each side of a ridge.

**CHAPTER C3**

**REFERENCED STANDARDS**

**SECTION C301**  
**REFERENCED STANDARDS**

**[BS] C301.1 General.** See Table C301.1 for standards that are referenced in various sections of this appendix. Standards are listed by the standard identification with the effective date, standard title, and the section or sections of this appendix that reference the standard.

**[BS] TABLE C301.1**  
**REFERENCED STANDARDS**

| <b><u>STANDARD ACRONYM</u></b> | <b><u>STANDARD NAME</u></b>            | <b><u>SECTIONS HEREIN REFERENCED</u></b>        |
|--------------------------------|--|---|
| <u>IBC—21</u>                  | <i>International Building Code®</i>    | <u>C101.3, C103.2,</u><br><u>C201.1, C201.2</u> |
| <u>IRC—21</u>                  | <i>International Residential Code®</i> | <u>C101.2, C101.3,</u><br><u>C103.2, C201.2</u> |

APPENDIX D  
**BOARD OF APPEALS**  
DELETED.